

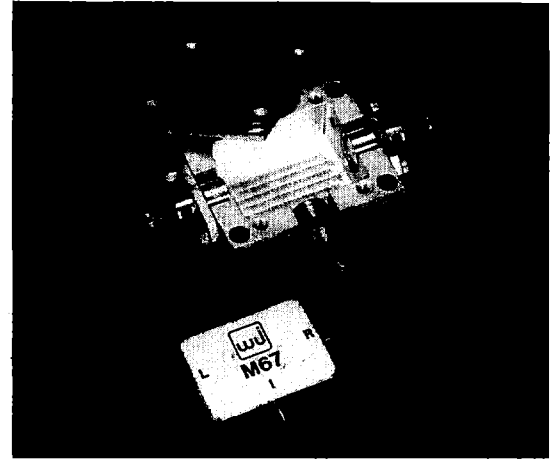

M67 / M67C

DOUBLE-BALANCED MIXER

- ◆ LO 7.0 TO 17.0 GHz
- ◆ RF 9.0 TO 15.0 GHz
- ◆ IF DC TO 2.5 GHz
- ◆ LO DRIVE +10 dBm (NOMINAL)
- ◆ LOW NOISE FIGURE: 6.5 dB (TYP.)
- ◆ MIL-M-28837 EQUIVALENT LEVEL SCREENING AVAILABLE



Guaranteed Specifications^{1,2}

Characteristics	Typ.	+25°C	-54°C to +85°C	Test Conditions
SSB Conversion Loss and SSB Noise Figure (Max.)	5.5 dB	7.0 dB	7.5 dB	f_R 9.5 to 13 GHz f_L 9 to 13.5 GHz f_I 30 to 500 MHz
	6.5 dB	8.5 dB	9.0 dB	f_R 9 to 15 GHz f_L 8 to 16 GHz f_I 30 to 1000 MHz
	6.5 dB	9.0 dB	9.5 dB	f_R 9 to 15 GHz f_L 7 to 17 GHz f_I 30 to 2000 MHz
	6.5 dB	9.0 dB	9.5 dB	f_R 9.5 to 13.5 GHz f_L 7 to 16 GHz f_I 30 to 2500 MHz
Isolation (Min.)				
L at R	40 dB	22 dB	20 dB	f_L 7 to 15 GHz
L at I	30 dB	10 dB	8 dB	f_L 15 to 17 GHz
	25 dB	15 dB	13 dB	f_L 7 to 17 GHz
Conversion Compression	1.0 dB			f_R Level +4 dBm f_L Level +10 dBm
Third-Order Input Intercept Point	+11 dBm			f_{R1} 11.50 GHz at -6 dBm f_{R2} 11.51 GHz at -6 dBm f_L = 12.0 GHz at +10 dBm
Single Tone IM Suppression				f_R 9 - 15 GHz at -10 dBm f_L 7 - 17 GHz at +10 dBm
f_L f_R				
2 x 2	50 dB			
3 x 3	55 dB			
4 x 3	> 70 dB			
4 x 4	> 70 dB			
5 x 4	> 70 dB			
5 x 5	> 70 dB			

Notes:

- Measured in a 50-ohm system with nominal LO drive and downconverter application only, unless otherwise specified. The I-Port frequency range extends to DC for phase detection, pulse modulation, or attenuator applications. I-Port VSWR degrades from a 50-ohm system at low IF frequencies.
- Typical values are measured at +25°C and are not guaranteed.

Absolute Maximum Ratings

Operating Temperature -54°C to +100°C
 Storage Temperature -65°C to +100°C
 Peak Input Power +23 dBm max. at +25°C, +20 dBm max. at +60°C
 Peak Input Current at 25°C 50 mA DC

Weight M67: 14 grams (0.5 oz.) max. M67C: 45 grams (1.6 oz.) max.

Outline Drawings

M67 (MINPAC)

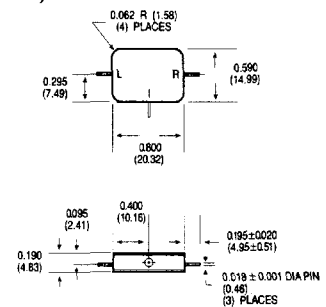

DIMENSIONS ARE IN INCHES (MILLIMETERS)
 ± 0.15 (.38) UNLESS OTHERWISE SPECIFIED

M67C (CONNECTORIZED)

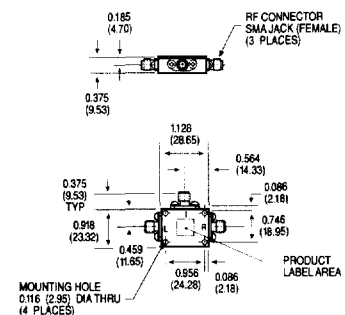

DIMENSIONS ARE IN INCHES (MILLIMETERS)
 ± 0.15 (.38) UNLESS OTHERWISE SPECIFIED

Conversion Loss vs. LO Drive

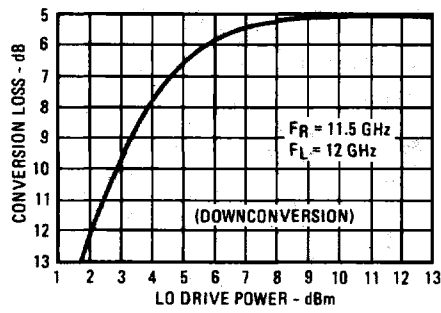

Conversion Loss vs. RF Input Power

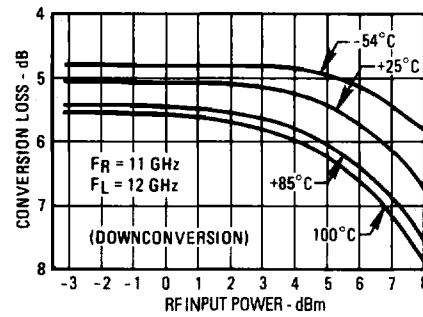

I-Port VSWR vs. f_L

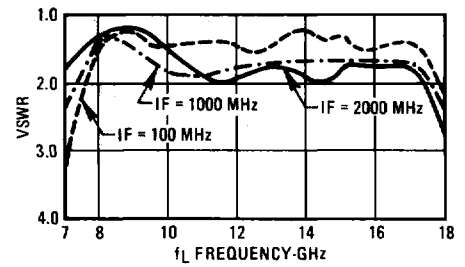

Conversion Loss vs. Frequency

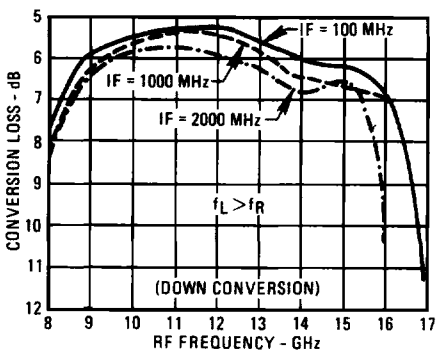

Isolation vs. Frequency

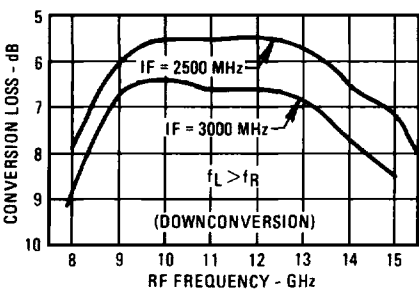
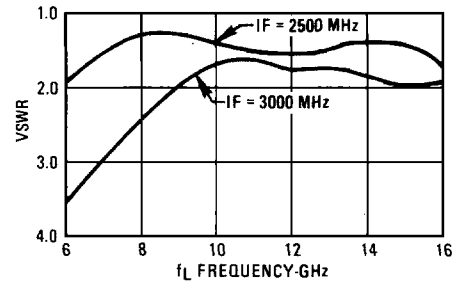
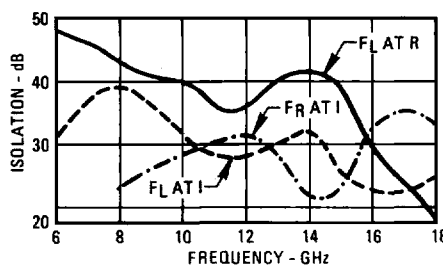

L-Port VSWR vs. Frequency

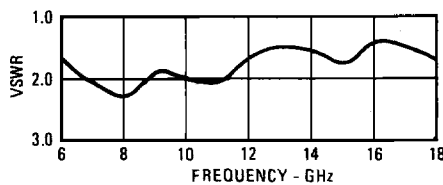

Two-Tone Intermodulation Performance

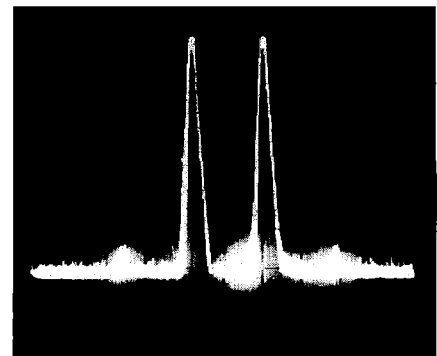

Typical Two-Tone Intermodulation Performance: $f_I = 1250$ MHz, $f_R = 12.0$ GHz ± 1 MHz at -10 dBm $f_L > f_R$, $f_L = 13.25$ GHz at $+10$ dBm. Vertical scale = 10 dB/cm.

Conversion Loss vs. Output Frequency

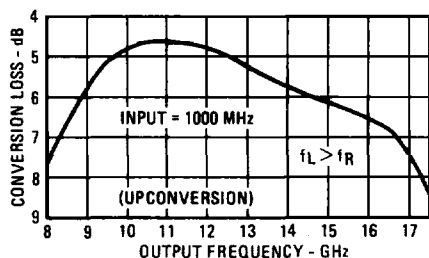

R-Port VSWR vs. Frequency

