

# DATA SHEET

Part No.	AN32059A
Package Code No.	UBGA055-W-3540AEA

---

**Contents**

■ Overview .....	3
■ Features .....	3
■ Applications .....	3
■ Package .....	3
■ Structure .....	3
■ Application Circuit Example (Block Diagram) .....	4
■ Pin Descriptions .....	5
■ Absolute Maximum Ratings .....	8
■ Operating Supply Voltage Range .....	8
■ Allowable Current and Voltage Ranges .....	9
■ Electrical Characteristics .....	10
■ Technical Data .....	22
• $P_D$ — $T_a$ Characteristic Diagram .....	22
■ Usage Notes .....	23

# AN32059A

## LED Driver for Mobile Devices

### ■ Overview

AN32059A provides LED driver for LCD back light, photo light driver, and RGB driver, and delivers voltage through built-in boost DC-DC converter. Additionally, it includes step-down DC-DC converter, and LDO and GPIO pins for power supply use.

### ■ Features

- Boost DC-DC converter (300 mA)
- Step-down DC-DC converter (350 mA)
- 7-ch LDO
- 6-ch GPIO
- SPI interface (1-ch)
- LED driver circuit (6-ch for back light, 4-ch for photo light, 3-ch for RGB)
- 1.2-MHz OSC

### ■ Applications

- Devices with battery, such as cell phone and camera

### ■ Package

- 55-pin wafer level chip size package (WLCSP)  
Size: 4.0 mm × 3.5 mm (0.5 mm pitch)

### ■ Structure

- Bi-CMOS IC

Application Circuit Example (Block Diagram)

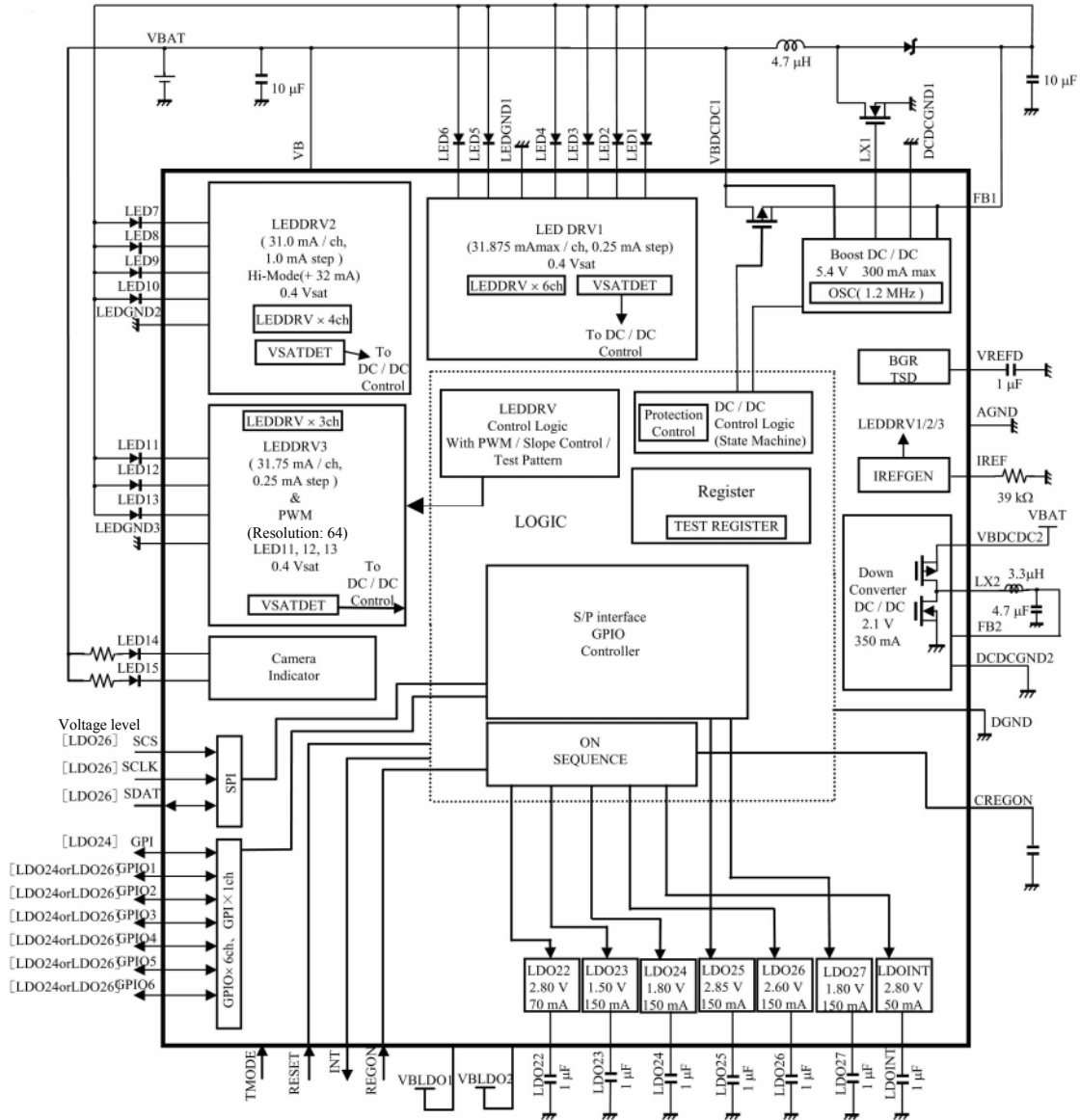

- Notes) • This application circuit is an example. Operation of mass production set is not guaranteed. Perform enough evaluation and verification on the design of mass production set.
- This block diagram is for explaining functions. Some circuit blocks may be omitted, or simplified.
  - Use rank-B ceramic capacitors with 20% or less capacitance change by DC bias voltage.

■ Pin Descriptions

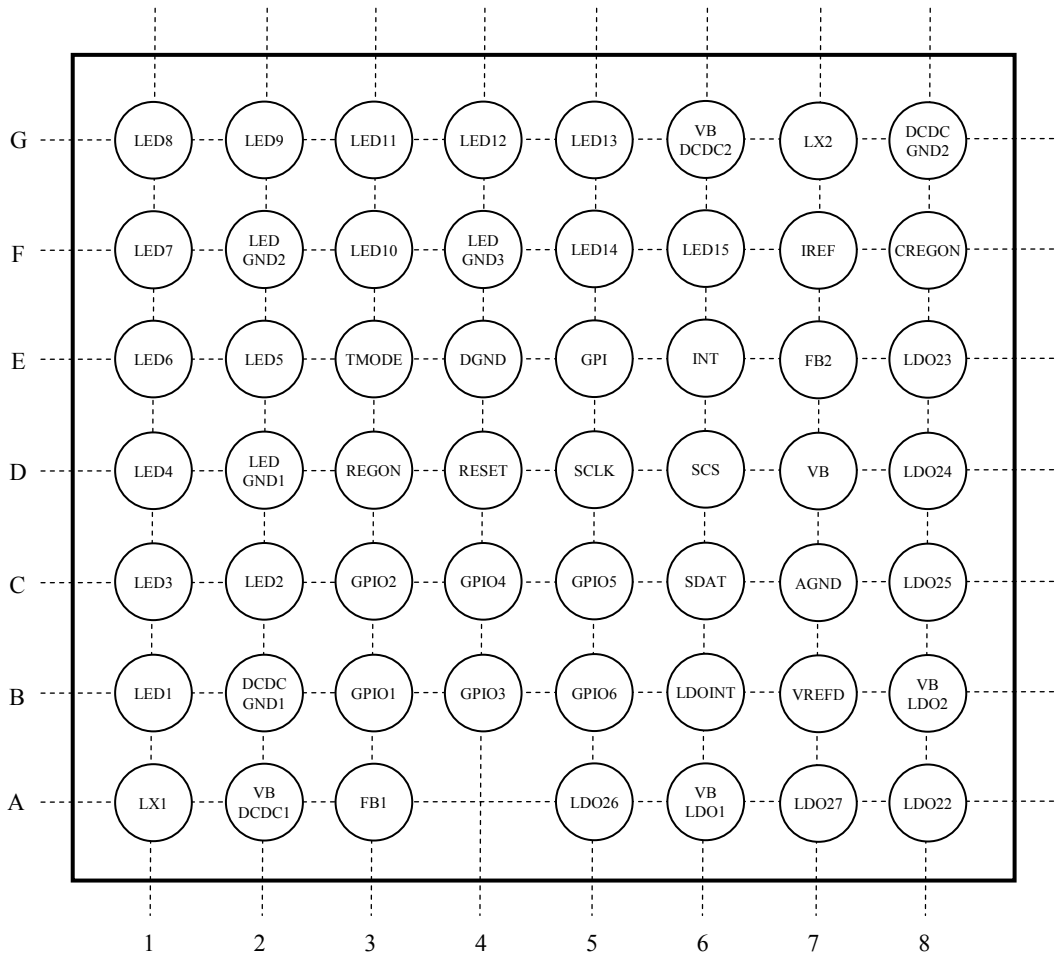

Bottom View

## ■ Pin Descriptions (continued)

Pin No.	Name	Type	Description
A1	LX1	Output	Gate drive for external N-ch MOS-Tr
A2	VBDCDC1	Power supply	Power connection to boost DC-DC converter
A3	FB1	Input	Feedback for boost DC-DC converter
A5	LDO26	Output	LDO26 output
A6	VBLDO1	Power supply	Power connection to LDO26, LDO27, and LDOINT
A7	LDO27	Output	LDO27 output
A8	LDO22	Output	LDO22 output
B1	LED1	Output	Constant current output of LED drive
B2	DCDCGND1	Ground	Ground for boost DC-DC converter
B3	GPIO1	Input/ Output	GPIO input/output port
B4	GPIO3	Input/ Output	GPIO input/output port
B5	GPIO6	Input/ Output	GPIO input/output port
B6	LDOINT	Output	LDOINT output
B7	VREFD	Output	Capacitor connection to band gap circuit
B8	VBLDO2	Power supply	Power connection to LDO22 and LDO25
C1	LED3	Output	Constant current output of LED drive
C2	LED2	Output	Constant current output of LED drive
C3	GPIO2	Input/ Output	GPIO input/output port
C4	GPIO4	Input/ Output	GPIO input/output port
C5	GPIO5	Input/ Output	GPIO input/output port
C6	SDAT	Input/ Output	Data input/output for SPI interface
C7	AGND	Ground	Analog ground
C8	LDO25	Output	LDO25 output
D1	LED4	Output	Constant current output of LED drive
D2	LEDGND1	Ground	Ground for constant current circuit of LED drive for LCD back light
D3	REGON	Input	LDO ON/OFF control
D4	RESET	Input	Reset input
D5	SCLK	Input	Clock input/output for SPI interface
D6	SCS	Input	Enable select for SPI interface
D7	VB	Power supply	Power connection to band gap and LDO circuits
D8	LDO24	Output	LDO24 output

## ■ Pin Descriptions (continued)

Pin No.	Name	Type	Description
E1	LED6	Output	Constant current output of LED drive
E2	LED5	Output	Constant current output of LED drive
E3	TMODE	Input	Mode switching
E4	DGND	Ground	Digital ground
E5	GPI	Input	GPI input port
E6	INT	Output	Interrupt output
E7	FB2	Output	Feedback for buck (step-down) DC-DC converter
E8	LDO23	Output	LDO23 output
F1	LED7	Output	Constant current output of LED drive
F2	LEDGND2	Ground	Ground for constant current circuit of LED drive for photo light
F3	LED10	Output	Constant current output of LED drive
F4	LEDGND3	Ground	Ground for constant current circuit of LED drive for BGR
F5	LED14	Output	Constant current output of LED drive
F6	LED15	Output	Constant current output of LED drive
F7	IREF	Output	Resistor connection for setting constant current value
F8	CREGON	Output	Capacitor connection for setting delay time of LDO22 activation
G1	LED8	Output	Constant current output of LED drive
G2	LED9	Output	Constant current output of LED drive
G3	LED11	Output	Constant current output of LED drive
G4	LED12	Output	Constant current output of LED drive
G5	LED13	Output	Constant current output of LED drive
G6	VBDCDC2	Power supply	Power connection to buck (step-down) DC-DC converter
G7	LX2	Output	Coil connection to buck (step-down) DC-DC converter
G8	DCDCGND2	Ground	Ground for buck (step-down) DC-DC converter

### ■ Absolute Maximum Ratings

Note) The absolute maximum ratings are the limit values beyond which the IC may be damaged. Operation is not guaranteed under these conditions.

A No.	Parameter	Symbol	Rating	Unit	Notes
1	Supply voltage	$V_{B_{MAX}}$	6.0	V	*1
2	Supply current	$I_{CC}$	—	A	—
3	Power dissipation	$P_D$	76.4	mW	*2
4	Operating ambient temperature	$T_{opr}$	- 30 to + 85	°C	*3
5	Storage temperature	$T_{stg}$	- 55 to + 125	°C	*3

Notes) \*1:  $V_{B_{MAX}} = VB = VBLDO1 = VBLDO2 = VBDCDC1 = VBDCDC2$

The values are defined, provided that the IC is used within all of the above absolute maximum ratings including the power dissipation.

\*2: The power dissipation shown is the value at  $T_a = 85^\circ\text{C}$  for the independent (unmounted) IC package without a heat sink.

When using this IC, refer to the  $P_D$ - $T_a$  diagram of the Technical Data and design the heat radiation with sufficient margin not to exceed the allowable value based on the conditions of power supply voltage, load, and ambient temperature.

\*3: All ratings are at  $T_a = 25^\circ\text{C}$  except the power dissipation, operating ambient temperature, and storage temperature.

### ■ Operating Supply Voltage Range

Parameter	Symbol	Range	Unit	Notes
Supply voltage range	VB VBLDO1 VBLDO2 VBDCDC1 VBDCDC2	3.1 to 4.6  (3.2 to 4.6 when LDO and DC-DC blocks have a maximum load)	V	*

Note) \*: The values are defined, provided that the IC is used within all of the above absolute maximum ratings including the power dissipation.

### ■ Allowable Current and Voltage Ranges

- Notes) • Rating voltages are voltages on each pin, with respect to the GND. GND denotes the voltage of AGND, LEDGND1, LEDGND2, LEDGND3, DCDCGND1, DCDCGND2, and DGND.  
(GND = AGND = LEDGND1 = LEDGND2 = LEDGND3 = DCDCGND1 = DCDCGND2 = DGND)
- VCC4V denotes the voltage of VB, VBLDO1, VBLDO2, VBDCDC1, and VBDCDC2  
(VB = VBLDO1 = VBLDO2 = VBDCDC1 = VBDCDC2)
  - Do not apply external currents or voltages to any pins except below.
  - "+" denotes the current to the IC and "-" denotes the current from the IC.

Pin No.	Pin Name	Rating Voltage	Unit	Notes
A1	LX1	- 0.3 to (VCC4V + 0.3)	V	*1,2
A2	VBDCDC1	0 to 4.6	V	—
A3	FB1	0 to 4.6	V	—
A5	LDO26	- 0.3 to (VCC4V + 0.3)	V	*1,2
A6	VBLDO1	0 to 4.6	V	—
A7	LDO27	- 0.3 to (VCC4V + 0.3)	V	*1,2
A8	LDO22	- 0.3 to (VCC4V + 0.3)	V	*1,2
B1	LED1	- 0.3 to (VFB1 + 0.3)	V	—
B3	GPIO1	- 0.3 to (VCC4V + 0.3)	V	*1,2
B4	GPIO3	- 0.3 to (VCC4V + 0.3)	V	*1,2
B5	GPIO6	- 0.3 to (VCC4V + 0.3)	V	*1,2
B6	LDOINT	- 0.3 to (VCC4V + 0.3)	V	*1,2
B7	VREFD	- 0.3 to (VCC4V + 0.3)	V	*1,2
B8	VBLDO2	0 to 4.6	V	—
C1	LED3	- 0.3 to (VFB1 + 0.3)	V	—
C2	LED2	- 0.3 to (VFB1 + 0.3)	V	—
C3	GPIO2	- 0.3 to (VCC4V + 0.3)	V	*1,2
C4	GPIO4	- 0.3 to (VCC4V + 0.3)	V	*1,2
C5	GPIO5	- 0.3 to (VCC4V + 0.3)	V	*1,2
C6	SDAT	- 0.3 to (VLDO26 + 0.3)	V	*2
C8	LDO25	- 0.3 to (VCC4V + 0.3)	V	*1,2
D1	LED4	- 0.3 to (VFB1 + 0.3)	V	—
D3	REGON	- 0.3 to (VCC4V + 0.3)	V	*1
D4	RESET	- 0.3 to (VCC4V + 0.3)	V	*1

Pin No.	Pin Name	Rating Voltage	Unit	Notes
D5	SCLK	- 0.3 to (VLDO26 + 0.3)	V	—
D6	SCS	- 0.3 to (VLDO26 + 0.3)	V	—
D7	VB	0 to 4.6	V	—
D8	LDO24	- 0.3 to (VFB2 + 0.3)	V	*2
E1	LED6	- 0.3 to (VFB1 + 0.3)	V	—
E2	LED5	- 0.3 to (VFB1 + 0.3)	V	—
E3	TMODE	- 0.3 to (VCC4V + 0.3)	V	*1
E5	GPI	- 0.3 to (VCC4V + 0.3)	V	*1
E6	INT	- 0.3 to (VCC4V + 0.3)	V	*1
E7	FB2	0 to 2.5	V	*2
E8	LDO23	- 0.3 to (VFB2 + 0.3)	V	*2
F1	LED7	- 0.3 to (VFB1 + 0.3)	V	—
F3	LED10	- 0.3 to (VFB1 + 0.3)	V	—
F5	LED14	- 0.3 to (VCC4V + 0.3)	V	*1
F6	LED15	- 0.3 to (VCC4V + 0.3)	V	*1
F7	IREF	- 0.3 to (VCC4V + 0.3)	V	*1,2
F8	CREGON	- 0.3 to (VCC4V + 0.3)	V	*1,2
G1	LED8	- 0.3 to (VFB1 + 0.3)	V	—
G2	LED9	- 0.3 to (VFB1 + 0.3)	V	—
G3	LED11	- 0.3 to (VFB1 + 0.3)	V	—
G4	LED12	- 0.3 to (VFB1 + 0.3)	V	—
G5	LED13	- 0.3 to (VFB1 + 0.3)	V	—
G6	VBDCDC2	0 to 4.6	V	—
G7	LX2	- 0.3 to (VCC4V + 0.3)	V	*1,2

Notes) \*1: The (VCC4V + 0.3) V must not exceed 4.6 V.

\*2: The values are specified for input. When using the pins as output, no external voltage or current input is allowed.

### ■ Electric Characteristics

VB = VBLDO1 = VBLDO2 = VBDCDC1 = VBDCDC2 = 3.6 V, FB2 = 2.1 V, TMODE = 0 V

Note) T<sub>a</sub> = 25°C ± 2°C, unless otherwise specified.

B No.	Parameter	Symbol	Conditions	Limits			Unit	Notes
				Min	Typ	Max		
<b>Consumption Current</b>								
1	Quiescent consumption current (Power supply off)	I <sub>OFF</sub>	VB = 3.6 V REGON = 0 V	—	8	20	μA	—
2	Operating consumption current (Normal mode)	I <sub>NORMAL</sub>	VB = 3.6 V REGON = 3.6 V spPOWERCNT1 = 57h spPOWERCNT2 = 00h	—	0.35	0.65	mA	—
3	Operating consumption current (all LDOs = ON)	I <sub>ALLLDO</sub>	VB = 3.6 V REGON = 3.6 V spPOWERCNT1 = 7Fh spPOWERCNT2 = 00h	—	0.42	0.78	mA	—
4	Operating consumption current (PS mode) (all LDOs = ON)	I <sub>PS</sub>	VB = 3.6 V REGON = 3.6 V spPOWERCNT1 = 7Fh spPOWERCNT2 = 3Fh	—	45	110	μA	—
5	Operating consumption current (DCDC6 = ON)	I <sub>DCDC6</sub>	VB = 3.6 V REGON = 3.6 V spPOWERCNT1 = 7Fh spPOWERCNT2 = 00h spPOWERCNT6 = 03h spSTATECHANGE = 04h	—	1.3	2.6	mA	—
<b>BGR Block</b>								
6	VREFD voltage	VREFD	Measurement value at V <sub>out</sub>	1.154	1.215	1.276	V	—

■ Electric Characteristics (continued)

VB = VBLDO1 = VBLDO2 = VBDCDC1 = VBDCDC2 = 3.6 V, FB2 = 2.1 V, TMODE = 0 V

Note) T<sub>a</sub> = 25°C ± 2°C, unless otherwise specified.

B No.	Parameter	Symbol	Conditions	Limits			Unit	Notes
				Min	Typ	Max		
LDO22								
7	Output voltage	VLDO22	I <sub>out</sub> = -40 mA	2.74	2.80	2.86	V	—
8	Load fluctuation	DVLDO22	I <sub>out</sub> = (-70 mA) ΔVLDO22 = VLDO22 - V <sub>out</sub>	0	—	45	mV	*1
9	Minimum output voltage	VLDO22 MIN	I <sub>out</sub> = -10 μA VLDO22MIN → spVLDO22 [2 : 0] : (000)	2.54	2.60	—	V	—
10	Maximum output voltage	VLDO22 MAX	I <sub>out</sub> = -10 μA VLDO22MAX → spVLDO22 [2 : 0] : (111)	—	2.95	3.01	V	—
11	Ripple removal rate (1)	VLDO22 R1	I <sub>out</sub> = -40 mA, FRR = 1 kHz VLDO22R1 = 20 log (V <sub>out</sub> / 0.3)	—	—	-35	dB	*2
12	Ripple removal rate (2)	VLDO22 R2	I <sub>out</sub> = -40 mA, FRR = 10 kHz VLDO22R2 = 20 log (V <sub>out</sub> / 0.3)	—	—	-20	dB	*2

Notes) \*1: See the Design Reference Manual No. 130.

\*2: See the Design Reference Manual Nos. 137 and 138.

■ Electric Characteristics (continued)

VB = VBLDO1 = VBLDO2 = VBDCDC1 = VBDCDC2 = 3.6 V, FB2 = 2.1 V, TMODE = 0 V

Note) T<sub>a</sub> = 25°C ± 2°C, unless otherwise specified.

B No.	Parameter	Symbol	Conditions	Limits			Unit	Notes
				Min	Typ	Max		
LDO23 Normal Mode								
13	Output voltage	VLDO23	I <sub>out</sub> = -80 mA	1.47	1.50	1.53	V	—
14	Load fluctuation	DVLDO23	I <sub>out</sub> = (-150 mA) ΔVLDO23 = VLDO23 - V <sub>out</sub>	0	—	45	mV	*3
15	Minimum output voltage	VLDO23 MIN	I <sub>out</sub> = -10 μA VLDO23MIN → spVLDO23 [2 : 0] : (000)	1.16	1.20	—	V	—
16	Maximum output voltage	VLDO23 MAX	I <sub>out</sub> = -10 μA VLDO23MAX → spVLDO23 [2 : 0] : (111)	—	1.55	1.59	V	—
17	Ripple removal rate (1)	VLDO23 R1	I <sub>out</sub> = -80 mA, FRR = 1 kHz VLDO23R1 = 20 log (V <sub>out</sub> / 0.3)	—	—	-40	dB	*4
18	Ripple removal rate (2)	VLDO23 R2	I <sub>out</sub> = -80 mA, FRR = 10 kHz VLDO23R2 = 20 log (V <sub>out</sub> / 0.3)	—	—	-30	dB	*4
LDO23 PS Mode								
19	Output voltage	VLDO23PS	I <sub>out</sub> = -3 mA Measurement value at V <sub>out</sub>	1.47	1.50	1.53	V	—
20	Minimum output voltage	VLDO23 PSMIN	I <sub>out</sub> = -10 μA VLDO23MIN → spVLDO23 [2 : 0] : (000)	1.16	1.20	—	V	—
21	Maximum output voltage	VLDO23 PSMAX	I <sub>out</sub> = -10 μA VLDO23MAX → spVLDO23 [2 : 0] : (111)	—	1.55	1.59	V	—

Notes) \*3: See the Design Reference Manual No. 131.

\*4: See the Design Reference Manual Nos. 139 and 140.

■ Electric Characteristics (continued)

VB = VBLDO1 = VBLDO2 = VBDCDC1 = VBDCDC2 = 3.6 V, FB2 = 2.1 V, TMODE = 0 V

Note) T<sub>a</sub> = 25°C ± 2°C, unless otherwise specified.

B No.	Parameter	Symbol	Conditions	Limits			Unit	Notes
				Min	Typ	Max		
<b>LDO24 Normal Mode</b>								
22	Output voltage	VLDO24	I <sub>out</sub> = -50 mA	1.76	1.80	1.84	V	—
23	Load fluctuation	DVLDO24	I <sub>out</sub> = (-150 mA) ΔVLDO24 = VLDO24 - V <sub>out</sub>	0	—	45	mV	*5
24	Minimum output voltage	VLDO24 MIN	I <sub>out</sub> = -10 μA VLDO24MIN → spVLDO24[2 : 0] : (000)	1.45	1.50	—	V	—
25	Maximum output voltage	VLDO24 MAX	I <sub>out</sub> = -10 μA VLDO24MAX → spVLDO24[2 : 0] : (111)	—	1.85	1.89	V	—
26	Ripple removal rate (1)	VLDO24 R1	I <sub>out</sub> = -50 mA, FRR = 1 kHz VLDO24R1 = 20 log (V <sub>out</sub> / 0.3)	—	—	-40	dB	*6
27	Ripple removal rate (2)	VLDO24 R2	I <sub>out</sub> = -50 mA, FRR = 10 kHz VLDO24R2 = 20 log (V <sub>out</sub> / 0.3)	—	—	-30	dB	*6
<b>LDO24 PS Mode</b>								
28	Output voltage	VLDO24PS	I <sub>out</sub> = -3 mA Measurement value at V <sub>out</sub>	1.76	1.80	1.84	V	—
29	Minimum output voltage	VLDO24 PSMIN	I <sub>out</sub> = -10 μA VLDO24MIN → spVLDO24[2 : 0] : (000)	1.45	1.50	—	V	—
30	Maximum output voltage	VLDO24 PSMAX	I <sub>out</sub> = -10 μA VLDO24MAX → spVLDO24[2 : 0] : (111)	—	1.85	1.89	V	—

Notes) \*5: See the Design Reference Manual No. 132.

\*6: See the Design Reference Manual Nos. 141 and 142.

■ Electric Characteristics (continued)

VB = VBLDO1 = VBLDO2 = VBDCDC1 = VBDCDC2 = 3.6 V, FB2 = 2.1 V, TMODE = 0 V

Note) T<sub>a</sub> = 25°C ± 2°C, unless otherwise specified.

B No.	Parameter	Symbol	Conditions	Limits			Unit	Notes
				Min	Typ	Max		
<b>LDO25 Normal Mode</b>								
31	Output voltage	VLDO25	I <sub>out</sub> = -100 mA	2.79	2.85	2.91	V	—
32	Load fluctuation	DVLDO25	I <sub>out</sub> = (-150 mA) ΔVLDO25 = VLDO25 - V <sub>out</sub>	0	—	45	mV	*7
33	Minimum output voltage	VLDO25 MIN	I <sub>out</sub> = -10 μA VLDO25MIN → spVLDO25[3 : 0] : (0000)	2.23	2.30	—	V	—
34	Maximum output voltage	VLDO25 MAX	I <sub>out</sub> = -10 μA VLDO25MAX → spVLDO25[3 : 0] : (1111)	—	3.05	3.12	V	—
35	Standby voltage	VLDO25S	No load	-0.3	—	0.3	V	—
36	Ripple removal rate (1)	VLDO25 R1	I <sub>out</sub> = -100 mA, FRR = 1 kHz VLDO25R1 = 20 log (V <sub>out</sub> / 0.3)	—	—	-40	dB	*8
37	Ripple removal rate (2)	VLDO25 R2	I <sub>out</sub> = -100 mA, FRR = 10 kHz VLDO25R2 = 20 log (V <sub>out</sub> / 0.3)	—	—	-30	dB	*8
<b>LDO25 PS Mode</b>								
38	Output voltage	VLDO25 PS	I <sub>out</sub> = -3 mA Measurement value at V <sub>out</sub>	2.79	2.85	2.91	V	—
39	Minimum output voltage	VLDO25 PSMIN	I <sub>out</sub> = -10 μA VLDO25MIN → spVLDO25[3 : 0] : (0000)	2.23	2.30	—	V	—
40	Maximum output voltage	VLDO25 PSMAX	I <sub>out</sub> = -10 μA VLDO25MAX → spVLDO25[3 : 0] : (1111)	—	3.05	3.12	V	—
41	Standby voltage	VLDO25 PSS	No load	-0.3	—	0.3	V	—

Notes) \*7: See the Design Reference Manual No. 133.

\*8: See the Design Reference Manual Nos. 143 and 144.

■ Electric Characteristics (continued)

VB = VBLDO1 = VBLDO2 = VBDCDC1 = VBDCDC2 = 3.6 V, FB2 = 2.1 V, TMODE = 0 V

Note)  $T_a = 25^\circ\text{C} \pm 2^\circ\text{C}$ , unless otherwise specified.

B No.	Parameter	Symbol	Conditions	Limits			Unit	Notes
				Min	Typ	Max		
<b>LDO26 Normal Mode</b>								
42	Output voltage	VLDO26	$I_{out} = -50 \text{ mA}$	2.54	2.60	2.66	V	—
43	Load fluctuation	DVLDO26	$I_{out} = (-150 \text{ mA})$ $\Delta VLDO26 = VLDO26 - V_{out}$	0	—	45	mV	*9
44	Minimum output voltage	VLDO26 MIN	$I_{out} = -10 \mu\text{A}$ VLDO26MIN → spVLDO26[1 : 0] : (00)	2.45	2.50	—	V	—
45	Maximum output voltage	VLDO26 MAX	$I_{out} = -10 \mu\text{A}$ VLDO26MAX → spVLDO26[1 : 0] : (11)	—	2.80	2.86	V	—
46	Ripple removal rate (1)	VLDO26 R1	$I_{out} = -50 \text{ mA}$ , FRR = 1 kHz VLDO26R1 = $20 \log (V_{out} / 0.3)$	—	—	-40	dB	*10
47	Ripple removal rate (2)	VLDO26 R2	$I_{out} = -50 \text{ mA}$ , FRR = 10 kHz VLDO26R2 = $20 \log (V_{out} / 0.3)$	—	—	-30	dB	*10
<b>LDO26 PS Mode</b>								
48	Output voltage	VLDO26PS	$I_{out} = -3 \text{ mA}$ Measurement value at $V_{out}$	2.54	2.60	2.66	V	—
49	Minimum output voltage	VLDO26 PSMIN	$I_{out} = -10 \mu\text{A}$ VLDO26MIN → spVLDO26[1 : 0] : (00)	2.45	2.50	—	V	—
50	Maximum output voltage	VLDO26 PSMAX	$I_{out} = -10 \mu\text{A}$ VLDO26MAX → spVLDO26[1 : 0] : (11)	—	2.80	2.86	V	—

Notes) \*9: See the Design Reference Manual No. 134.

\*10: See the Design Reference Manual Nos. 145 and 146.

■ Electric Characteristics (continued)

VB = VBLDO1 = VBLDO2 = VBDCDC1 = VBDCDC2 = 3.6 V, FB2 = 2.1 V, TMODE = 0 V

Note) T<sub>a</sub> = 25°C ± 2°C, unless otherwise specified.

B No.	Parameter	Symbol	Conditions	Limits			Unit	Notes
				Min	Typ	Max		
<b>LDO27 Normal Mode</b>								
51	Output voltage	VLDO27	I <sub>out</sub> = -100 mA	1.76	1.80	1.84	V	—
52	Load fluctuation	DVLDO27	I <sub>out</sub> = (-150 mA) ΔVLDO27 = VLDO27 - V <sub>out</sub>	0	—	45	mV	*11
53	Minimum output voltage	VLDO27 MIN	I <sub>out</sub> = -10 μA VLDO27MIN → spLDO27DC to A : (000)	1.45	1.50	—	V	—
54	Maximum output voltage	VLDO27 MAX	I <sub>out</sub> = -10 μA VLDO27MAX → spLDO27DC to A : (000)	—	1.85	1.89	V	—
55	Standby voltage	VLDO27S	No load	-0.3	—	0.3	V	—
56	Ripple removal rate (1)	VLDO27 R1	I <sub>out</sub> = -100 mA, FRR = 1 kHz VLDO27R1 = 20 log (V <sub>out</sub> / 0.3)	—	—	-40	dB	*12
57	Ripple removal rate (2)	VLDO27 R2	I <sub>out</sub> = -100 mA, FRR = 10 kHz VLDO27R2 = 20 log (V <sub>out</sub> / 0.3)	—	—	-30	dB	*12
<b>LDO27 PS Mode</b>								
58	Output voltage	VLDO27PS	I <sub>out</sub> = -3 mA Measurement value at V <sub>out</sub>	1.76	1.80	1.84	V	—
59	Minimum output voltage	VLDO27 PSMIN	I <sub>out</sub> = -10 μA VLDO27MIN → spLDO27DC to A : (000)	1.45	1.50	—	V	—
60	Maximum output voltage	VLDO27 PSMAX	I <sub>out</sub> = -10 μA VLDO27MAX → spLDO27DC to A : (000)	—	1.85	1.89	V	—
61	Standby voltage	VLDO27 PSS	No load	-0.3	—	0.3	V	—

Notes) \*11: See the Design Reference Manual No. 135.

\*12: See the Design Reference Manual Nos. 147 and 148.

■ Electric Characteristics (continued)

VB = VBLDO1 = VBLDO2 = VBDCDC1 = VBDCDC2 = 3.6 V, FB2 = 2.1 V, TMODE = 0 V

Note)  $T_a = 25^\circ\text{C} \pm 2^\circ\text{C}$ , unless otherwise specified.

B No.	Parameter	Symbol	Conditions	Limits			Unit	Notes
				Min	Typ	Max		
<b>LDOINT</b>								
62	Output voltage	VLDOINT	$I_{out} = -10 \text{ mA}$	2.74	2.80	2.86	V	—
63	Load fluctuation	DVLDOINT	$I_{out} = (-50 \text{ mA})$ $\Delta VLDOINT = VLDOINT - V_{out}$	0	—	45	mV	*13
64	Ripple removal rate (1)	VLDOINT R1	$I_{out} = -10 \text{ mA}$ , FRR = 1 kHz $VLDOINTR1 = 20 \log (V_{out} / 0.3)$	—	—	-35	dB	*14
65	Ripple removal rate (2)	VLDOINT R2	$I_{out} = -10 \text{ mA}$ , FRR = 10 kHz $VLDOINTR2 = 20 \log (V_{out} / 0.3)$	—	—	-20	dB	*14
<b>DCDC5 Normal Mode</b> with Coil MIPS2520D3R3 (L = 3.3 $\mu\text{H}$ ) and External Ceramic Capacitor Connected (C = 4.7 $\mu\text{F}$ )								
66	Output voltage	VDD5	$I_{out} = -150 \text{ mA}$	2.03	2.10	2.17	V	—
67	Load fluctuation	DVDD5	$I_{out} = -350 \text{ mA}$ $\Delta VDD5 =  VDD5 - V_{out} $	0	—	30	mV	—
<b>DCDC5 PS Mode</b>								
68	Output voltage	VDD5PS	$I_{out} = -5 \text{ mA}$ Measurement value at $V_{out}$	2.03	2.10	2.17	V	—
<b>DCDC6</b>								
69	Output voltage	VDD6	$I_{out} = -200 \text{ mA}$	5.2	5.4	5.6	V	—
70	Oscillation frequency	FDD6	—	960	1200	1440	kHz	—
<b>VB Through Switch</b>								
71	Resistance at switch on	RVBS	$V_{in} = 3.6 \text{ V}$ $I_{in} = 5 \text{ mA}$	—	0.3	1	$\Omega$	—

Notes) \*13: See the Design Reference Manual No. 136.

\*14: See the Design Reference Manual Nos. 149 and 150.

### ■ Electric Characteristics (continued)

VB = VBLDO1 = VBLDO2 = VBDCDC1 = VBDCDC2 = 3.6 V, FB2 = 2.1 V, TMODE = 0 V

Note) T<sub>a</sub> = 25°C ± 2°C, unless otherwise specified.

B No.	Parameter	Symbol	Conditions	Limits			Unit	Notes
				Min	Typ	Max		
LED1 to 6 for LCD Back Light (When Assigned to LED Group 1)								
72	Minimum current value 1	Imin11	—	0.112	0.125	0.138	mA	*15
73	Minimum current value 2	Imin12	—	0.95	1.00	1.05	mA	*15
74	Maximum current value	Imax1	—	30.281	31.875	33.469	mA	*15
75	Current step	Istep1	—	0.015	0.125	0.235	mA	*15
76	Saturation voltage	Vsat1	at maximum	—	0.4	0.52	V	*15
LED1 to 6 for LCD Back Light (When Assigned to LED Group 2)								
77	Minimum current value 1	Imin11	—	0.225	0.25	0.275	mA	*15
78	Minimum current value 2	Imin12	—	0.95	1.00	1.05	mA	*15
79	Maximum current value	Imax1	—	30.16	31.75	33.34	mA	*15
80	Current step	Istep1	—	0.05	0.25	0.45	mA	*15
81	Saturation voltage	Vsat1	at maximum	—	0.4	0.52	V	*15
LED7 to 10 for Photo Light								
82	Minimum current value	Imin21	—	0.95	1.00	1.05	mA	*15
83	Maximum current value	Imax21	—	29.45	31.00	32.55	mA	*15
84	Current step	Istep21	—	0.20	1.00	1.80	mA	*15
85	Saturation voltage	Vsat21	at maximum	—	0.4	0.52	V	*15
LED7 to 10 for Photo Light (at Enhanced Emission Mode)								
86	Minimum current value	Imin22	Enhanced emission mode	30.40	32.00	33.60	mA	*15
87	Maximum current value	Imax22	Enhanced emission mode	59.85	63.00	66.15	mA	*15
88	Current step	Istep22	Enhanced emission mode	0.20	1.00	1.80	mA	*15
89	Saturation voltage	Vsat22	at maximum	—	0.4	0.60	V	*15
LED11 to 13 for Incoming RGB								
90	Minimum current value 1	Imin31	—	0.225	0.25	0.275	mA	*15
91	Minimum current value 2	Imin32	—	0.95	1.00	1.05	mA	*15
92	Maximum current value	Imax3	—	30.16	31.75	33.34	mA	*15
93	Current step	Istep3	—	0.05	0.25	0.45	mA	*15
94	Saturation voltage	Vsat3	at maximum	—	0.4	0.52	V	*15
LED14 to 15 for Camera Indicator								
95	Saturation voltage	Vcam	Iout = 10 mA	—	0.15	0.2	V	*15

Note) \*15: When IREF external resistor value is 39 kΩ.

■ Electric Characteristics (continued)

VB = VBLDO1 = VBLDO2 = VBDCDC1 = VBDCDC2 = 3.6 V, FB2 = 2.1 V, TMODE = 0 V

Note) T<sub>a</sub> = 25°C ± 2°C, unless otherwise specified.

B No.	Parameter	Symbol	Conditions	Limits			Unit	Notes
				Min	Typ	Max		
SCS, SCLK, SDAT (Input), RESET								
96	High-level input voltage range	VIH1	—	LDO26 × 0.7	—	LDO26 + 0.2	V	—
97	Low-level input voltage range	VIL1	—	-0.2	—	LDO26 × 0.3	V	—
GPI								
98	High-level input voltage range	VIH1	—	LDO24 × 0.7	—	VB + 0.2	V	—
99	Low-level input voltage range	VIL1	—	-0.2	—	LDO24 × 0.3	V	—
GPIO1 to 6								
100	High-level input voltage range (1) at 1.8-V mode operation	VIH2	IOVDDSEL = 0	LDO24 × 0.7	—	LDO24 + 0.2	V	—
101	Low-level input voltage range (1) at 1.8-V mode operation	VIL2	IOVDDSEL = 0	-0.2	—	LDO24 × 0.3	V	—
102	High-level input voltage range (2) at 2.8-V mode operation	VIH3	IOVDDSEL = 1	LDO26 × 0.7	—	LDO26 + 0.2	V	—
103	Low-level input voltage range (2) at 2.8-V mode operation	VIL3	IOVDDSEL = 1	-0.2	—	LDO26 × 0.3	V	—
104	High-level output voltage (1)	VOH1	IOVDDSEL = 0 I <sub>out</sub> = -3 mA	LDO24 × 0.7	—	LDO24 + 0.2	V	—
105	Low-level output voltage (1)	VOL1	IOVDDSEL = 0 I <sub>out</sub> = 3 mA	-0.2	—	LDO24 × 0.3	V	—
106	High-level output voltage (2)	VOH2	IOVDDSEL = 1 I <sub>out</sub> = -3 mA	LDO26 × 0.7	—	LDO26 + 0.2	V	—
107	Low-level output voltage (2)	VOL2	IOVDDSEL = 1 I <sub>out</sub> = 3 mA	-0.2	—	LDO26 × 0.3	V	—

■ Electric Characteristics (continued)

VB = VBLDO1 = VBLDO2 = VBDCDC1 = VBDCDC2 = 3.6 V, FB2 = 2.1 V, TMODE = 0 V

Note) T<sub>a</sub> = 25°C ± 2°C, unless otherwise specified.

B No.	Parameter	Symbol	Conditions	Limits			Unit	Notes
				Min	Typ	Max		
REGON								
108	High-level input voltage range	VIH4	—	VB × 0.7	—	VB + 0.2	V	—
109	Low-level input voltage range	VIL4	—	-0.2	—	VB × 0.3	V	—
SDAT (Output)								
110	High-level output voltage	VOH3	I <sub>out</sub> = -3 mA	LDO26 × 0.7	—	LDO26 + 0.2	V	—
111	Low-level output voltage	VOL3	I <sub>out</sub> = 3 mA	-0.2	—	LDO26 × 0.3	V	—
GPIO1 to 6								
112	Pull-up resistance	RPL	IOPLU = 1 IOPLD = 0	50	100	150	kΩ	—
113	Pull-down resistance	RPD1	IOPLD = 1	50	100	150	kΩ	—
TMODE								
114	Pull-down resistance	RPD2	—	50	100	150	kΩ	—

■ Electric Characteristics (continued)

VB = VBLDO1 = VBLDO2 = VBDCDC1 = VBDCDC2 = 3.6 V, FB2 = 2.1 V, TMODE = 3.6 V

Note)  $T_a = 25^\circ\text{C} \pm 2^\circ\text{C}$ , unless otherwise specified.

B No.	Parameter	Symbol	Conditions	Limits			Unit	Notes
				Min	Typ	Max		
LDO26 Normal Mode (TMODE = 3.6 V with DAC setting disabled)								
115	Output voltage	VLDO26T	Iout = -50 mA	1.79	1.85	1.91	V	—
LDO26 PS Mode (TMODE = 3.6 V with DAC setting disabled)								
116	Output voltage	VLDO26PS T	Iout = -3 mA Measurement value at Vout	1.79	1.85	1.91	V	—
DCDC5 (TMODE = 3.6 V with PS mode fixed)								
117	Output voltage	VDD5PST	Iout = -5 mA Measurement value at Vout	2.76	2.85	2.94	V	—

■ Technical Data

- $P_D - T_a$  Characteristic Diagram

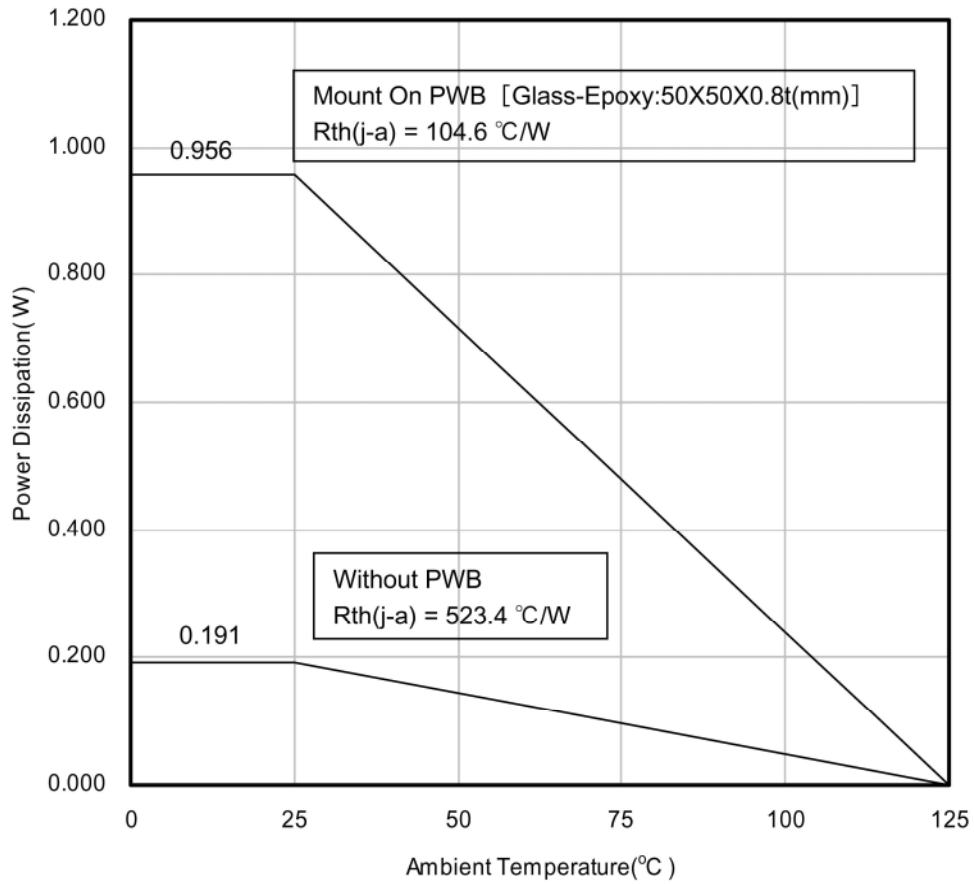

**■ Usage Notes****• Special Attention and Precaution in Using the IC**

1. This IC is intended to be used for general electronic equipment [LED driver for mobile devices].  
Consult our sales staff in advance for information on the following applications:
  - Special applications in which exceptional quality and reliability are required, or if the failure or malfunction of this IC may directly jeopardize life or harm the human body.
  - Any applications other than the standard applications intended.
    - (1) Space appliance (such as artificial satellite, and rocket)
    - (2) Traffic control equipment (such as for automobile, airplane, train, and ship)
    - (3) Medical equipment for life support
    - (4) Submarine transponder
    - (5) Control equipment for power plant
    - (6) Disaster prevention and security device
    - (7) Weapon
    - (8) Others: Applications requiring reliability, equivalent to that of (1) to (7).Otherwise, we will not be liable for any defect which may arise later in your equipment.
2. This IC might smoke or ignite if it is mounted in the wrong direction onto the PCB (printed circuit board). Pay attention to the direction of it.
3. Pay attention to the pattern layout of PCB in order to prevent damage due to pin-to-pin short. For pin configuration, see the Pin Descriptions.
4. Conduct a visual inspection on PCBs sufficiently prior to supplying power to the IC, to prevent damage due to pin-to-pin solder-bridge. Also, conduct a technical verification to the mounting quality sufficiently, to prevent damage due to adhering conductive foreign substance such as solder scrap during transportation.
5. Since this IC might be damaged or occasionally smoke if abnormal state occurs, such as output-VCC short (power supply fault), output-GND short (ground fault), output-to-output short (load short), or pin-to-pin leakage, care must be taken in the use of the IC. Safety measures, such as fuse installation, are recommended in order to avoid such risks.
6. When designing your equipment with this IC, conduct safety checks including the long-term reliability for each equipment.
7. When designing application systems with this IC, read the Usage Notes described in this document thoroughly.
8. This IC has a structure that the chip is exposed to external. In case of using it in the light, functions and characteristics are not guaranteed. Please treat this IC not to be exposed to light during operation or testing process.
9. Since the chip surface is basically at ground potential, avoid the chip surface being in contact with metal shielding and others when designing your equipment.

## Request for your special attention and precautions in using the technical information and semiconductors described in this book

- (1) If any of the products or technical information described in this book is to be exported or provided to non-residents, the laws and regulations of the exporting country, especially, those with regard to security export control, must be observed.
- (2) The technical information described in this book is intended only to show the main characteristics and application circuit examples of the products. No license is granted in and to any intellectual property right or other right owned by Panasonic Corporation or any other company. Therefore, no responsibility is assumed by our company as to the infringement upon any such right owned by any other company which may arise as a result of the use of technical information described in this book.
- (3) The products described in this book are intended to be used for general applications (such as office equipment, communications equipment, measuring instruments and household appliances), or for specific applications as expressly stated in this book.  
Consult our sales staff in advance for information on the following applications:
  - Special applications (such as for airplanes, aerospace, automotive equipment, traffic signaling equipment, combustion equipment, life support systems and safety devices) in which exceptional quality and reliability are required, or if the failure or malfunction of the products may directly jeopardize life or harm the human body.It is to be understood that our company shall not be held responsible for any damage incurred as a result of or in connection with your using the products described in this book for any special application, unless our company agrees to your using the products in this book for any special application.
- (4) The products and product specifications described in this book are subject to change without notice for modification and/or improvement. At the final stage of your design, purchasing, or use of the products, therefore, ask for the most up-to-date Product Standards in advance to make sure that the latest specifications satisfy your requirements.
- (5) When designing your equipment, comply with the range of absolute maximum rating and the guaranteed operating conditions (operating power supply voltage and operating environment etc.). Especially, please be careful not to exceed the range of absolute maximum rating on the transient state, such as power-on, power-off and mode-switching. Otherwise, we will not be liable for any defect which may arise later in your equipment.  
Even when the products are used within the guaranteed values, take into the consideration of incidence of break down and failure mode, possible to occur to semiconductor products. Measures on the systems such as redundant design, arresting the spread of fire or preventing glitch are recommended in order to prevent physical injury, fire, social damages, for example, by using the products.
- (6) Comply with the instructions for use in order to prevent breakdown and characteristics change due to external factors (ESD, EOS, thermal stress and mechanical stress) at the time of handling, mounting or at customer's process. When using products for which damp-proof packing is required, satisfy the conditions, such as shelf life and the elapsed time since first opening the packages.
- (7) This book may be not reprinted or reproduced whether wholly or partially, without the prior written permission of our company.