

LM211/LM311

LINEAR INTEGRATED CIRCUIT

VOLTAGE COMPARATOR

The LM211 series is a monolithic, low input current voltage comparator.

FEATURE

- Low input bias current: MAX 250nA.
- Low input offset current: MAX 50nA.
- Differential Input Voltage: $\pm 30V$.
- Power supply voltage: single 5.0V supply to $\pm 15V$.
- Offset voltage null capability.
- Strobe capability.

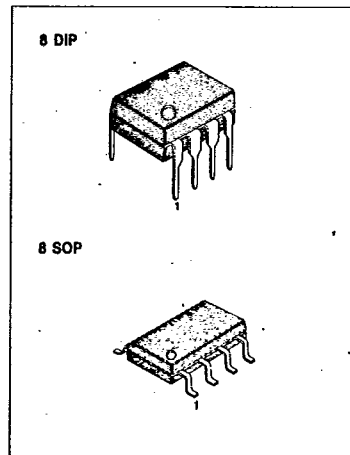

BLOCK DIAGRAM

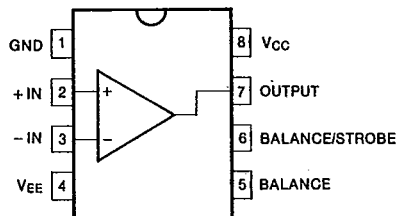

ORDERING INFORMATION

Device	Package	Operating Temperature
LM211N	8 DIP	-25 ~ +85°C
LM211D	8 SOP	
LM311N	8 DIP	0 ~ +70°C
LM311D	8 SOP	

SCHEMATIC DIAGRAM

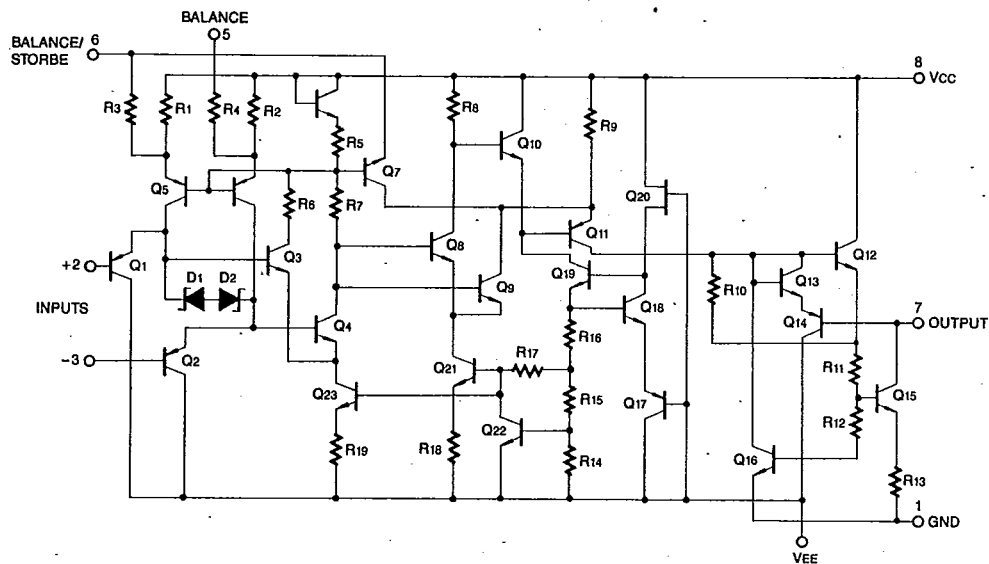

LM211/LM311

LINEAR INTEGRATED CIRCUIT

ABSOLUTE MAXIMUM RATINGS

Characteristic	Symbol	Value	Unit
Total Supply Voltage	V_S	36	V
Output to Negative Supply Voltage LM211	$V_O - V_{EE}$	50	V
LM311		40	V
Ground to Negative Supply Voltage	V_{EE}	30	V
Differential Input Voltage	V_{ID}	± 30	V
Input Voltage	V_{IN}	± 15	V
Output Short Circuit Duration		10	sec
Voltage at Strobe Pin		V_{CC} to $V_{CC}-5.0$	V
Power Dissipation	P_D	500	mW
Operating Temperature LM211	T_{opr}	$-25 \sim +85$	$^{\circ}C$
LM311		$0 \sim +70$	$^{\circ}C$
Storage Temperature	T_{stg}	$-65 \sim +150$	$^{\circ}C$

ELECTRICAL CHARACTERISTICS ($V_{CC} = 15V$, $V_{EE} = -15V$, $T_a = 25^{\circ}C$, unless otherwise specified)

Characteristic	Symbol	Test Conditions	LM211			LM311			Unit
			Min	Typ	Max	Min	Typ	Max	
Input Offset Voltage (NOTE1)	V_{IO}	$R_S \leq 50K\Omega$ $T_{amin} \leq T_a \leq T_{amax}$		0.7	3.0		2.0	7.5	mV
					4.0			10	
Input Offset Current (NOTE1)	I_{IO}	$T_{amin} \leq T_a \leq T_{amax}$		4.0	10		6	50	nA
					20			70	
Input Bias Current	I_{IB}	$T_{amin} \leq T_a \leq T_{amax}$		60	100		100	250	nA
					150			300	
Voltage Gain	A_V		40	200		40	200	V/mV	
Response Time (NOTE2)	t_r			200			200	nS	
Saturation Voltage	V_{sat}	$V_{id} \leq -5.0mV$, $I_o = 50mA$		0.75	1.5				V
		$V_{id} = -10.0mV$, $I_o = 50mA$					0.75	1.5	
		$V_{CC} \geq 4.5V$, $V_{EE} = 0V$, $I_{sink} \leq 8.0mA$ $V_{id} \leq -6.0mV$ $T_{amin} \leq T_a \leq T_{amax}$		0.23	0.4				
		$V_{id} \leq -10.0mV$					0.23	0.4	
Strobe "ON" Current	I_S			3			3	mA	
Output Leakage Current	I_{leak}	$V_{id} \geq 5.0mV$ $V_o = 35V$		0.2	10				nA
		$V_{id} \geq 10mV$ $V_o = 35V$					0.2	50	
		$V_{id} \geq 5.0mV$, $V_o = 35V$, $T_{amin} < T_a < T_{amax}$		0.1	0.5				
Input Voltage Range	V_{ICR}	$T_{amin} \leq T_a \leq T_{amax}$	-14.5	-14.7 to 13.8	13.0	-14.5	-14.7 to 13.8	13.0	V
Positive Supply Current	I_{CC}			2.4	6.0		2.4	7.5	mA
Negative Supply Current	I_{EE}			-1.3	-5.0		-1.3	-5.0	mA
Strobe Current	I_{strobe}			3			3		mA

NOTE 1 $T_{amin} \leq T_a \leq T_{amax}$ LM211: $T_{amin} = -25^{\circ}C$, $T_{amax} = +85^{\circ}C$ LM311: $T_{amin} = 0^{\circ}C$, $T_{amax} = +70^{\circ}C$

NOTE 2 The response time specified is for a 100mV input step with 5mV over drive

LM211/LM311

LINEAR INTEGRATED CIRCUIT

TYPICAL PERFORMANCE CHARACTERISTICS

INPUT BIAS CURRENT V_s TEMPERATURE

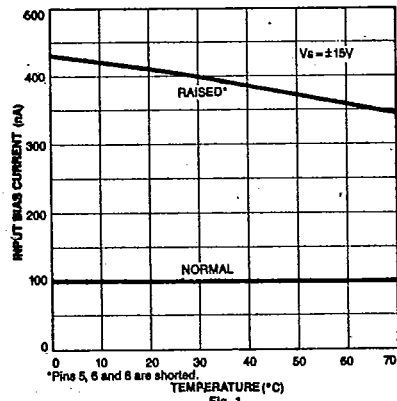

Fig. 1

INPUT OFFSET CURRENT V_s TEMPERATURE

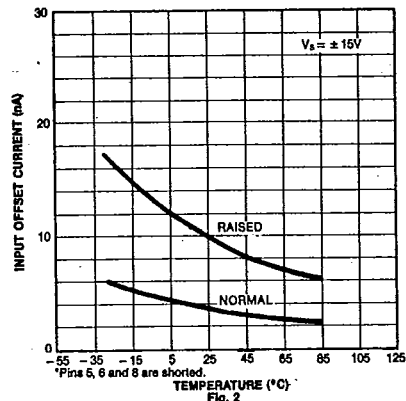

Fig. 2

OFFSET VOLTAGE V_s INPUT RESISTANCE

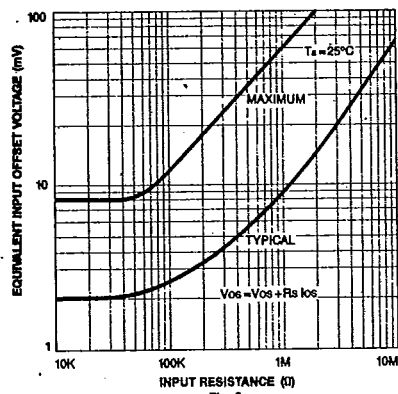

Fig. 3

INPUT BIAS CURRENT V_s DIFFERENTIAL INPUT VOLTAGE

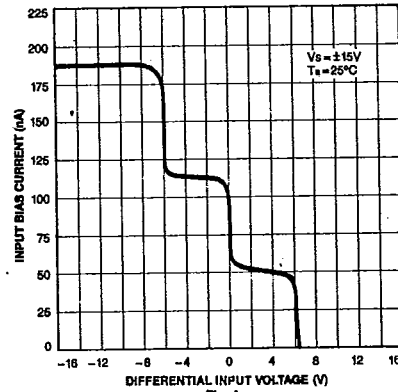

Fig. 4

COMMON MODE LIMITS V_s TEMPERATURE

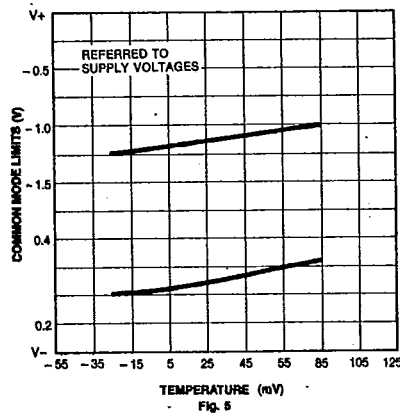

Fig. 5

OUTPUT VOLTAGE V_s DIFFERENTIAL INPUT VOLTAGE

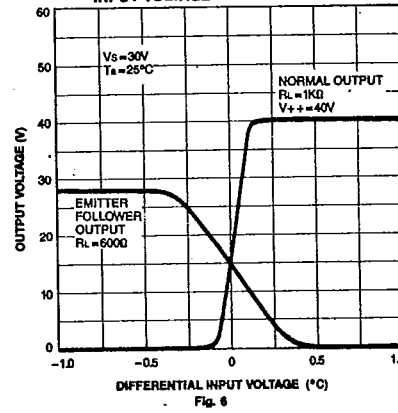
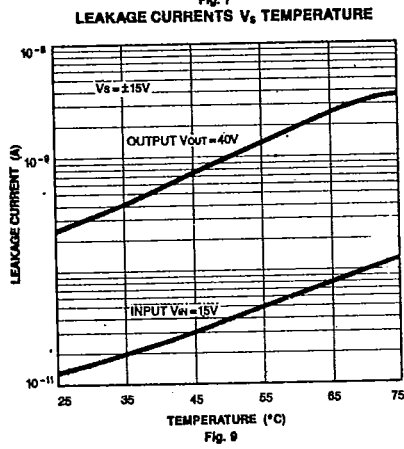
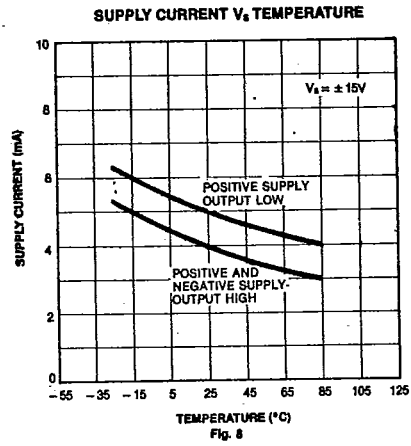
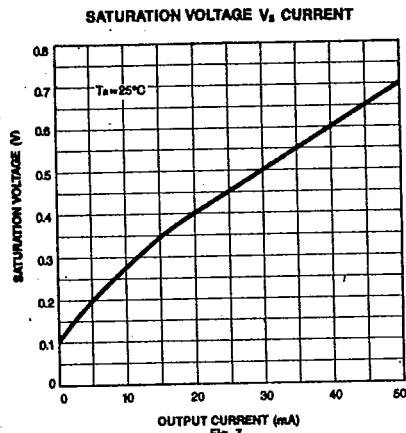

Fig. 6

LM211/LM311

LINEAR INTEGRATED CIRCUIT



LM211/LM311

LINEAR INTEGRATED CIRCUIT

TYPICAL APPLICATIONS

Switching Power Amplifier

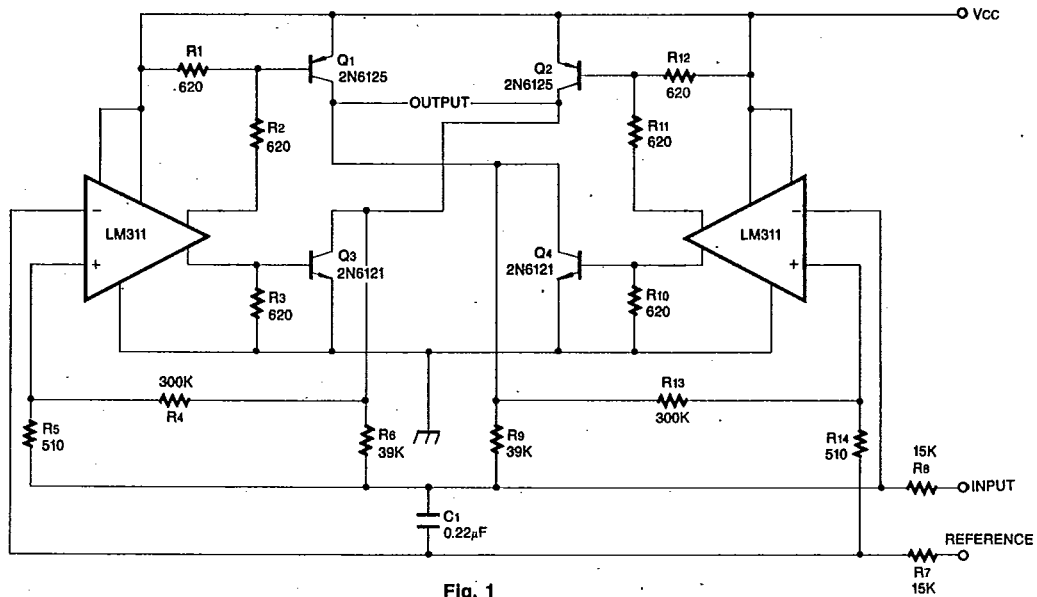

Relay Driver with Strobe

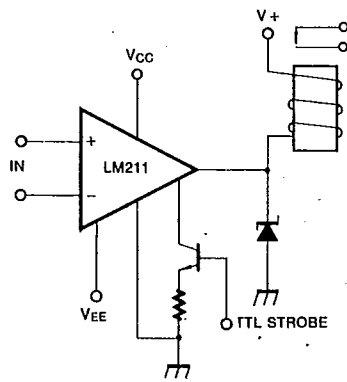

Digital Transmission Isolator

