

## **RXM-4** **Fiber-Optic Receiver Module** **High-Sensitivity and Wide Dynamic Range**

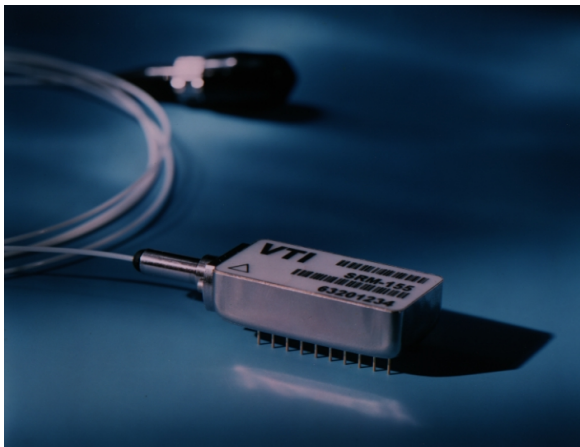

The RXM-4 4Mb/s Fiber-Optic Receiver Module

### **Features**

- 4.096 MB/s Compatible
- PECL Data Outputs
- Single +5 Volt Supply
- Operation at 1300 nm and 1550 nm
- 0° to +70°C Operation
- -45dBm minimum sensitivity
- Multi-Sourced 20 Pin DIL Footprint

### **Applications**

- Pin-based high sensitivity Network monitoring Receiver Applications @ 4.096 Mb/s
- Supervisory Channel

### **Description**

VI's RXM-4 is a PIN based low speed fiber-optic receiver for use in transmission systems of less than 100 km in length. It is powered by a single +5V power supply and is housed in a 20 pin DIL package. It's primary features include high sensitivity, wide dynamic range, and is PECL compatible. It is available with a multi-mode fiber pigtail with either a ST or LC connector.

# RXM-4 Fiber Optic High Sensitivity Receiver Module

## Product Data Sheet

---

### Functional Overview

This highly integrated module converts a 4.096 Mb/s fiber-optic NRZ signal to differential PECL data outputs.

A single +5 Volt supply provides bias for the module's preamplifier, and Quantizer. The photodiode is biased internally. All elements are integrated into fiber-coupled 1.3" X 0.635" 20 pin DIL package. The RXM-4 footprint and pinout are industry common for ease of integration.

The optical signal is coupled through a 62.5  $\mu\text{m}$  multimode optical fiber to a hermetic module which encases an InGaAs PiN-photodiode and preamplifier. The PiN-photodiode converts the optical signal to an electrical current.

The signal is then converted to a voltage and amplified by a low noise transimpedance amplifier, further gain is provided by the quantizer. Following the quantizer is an ECL 10H116-type differential buffer.

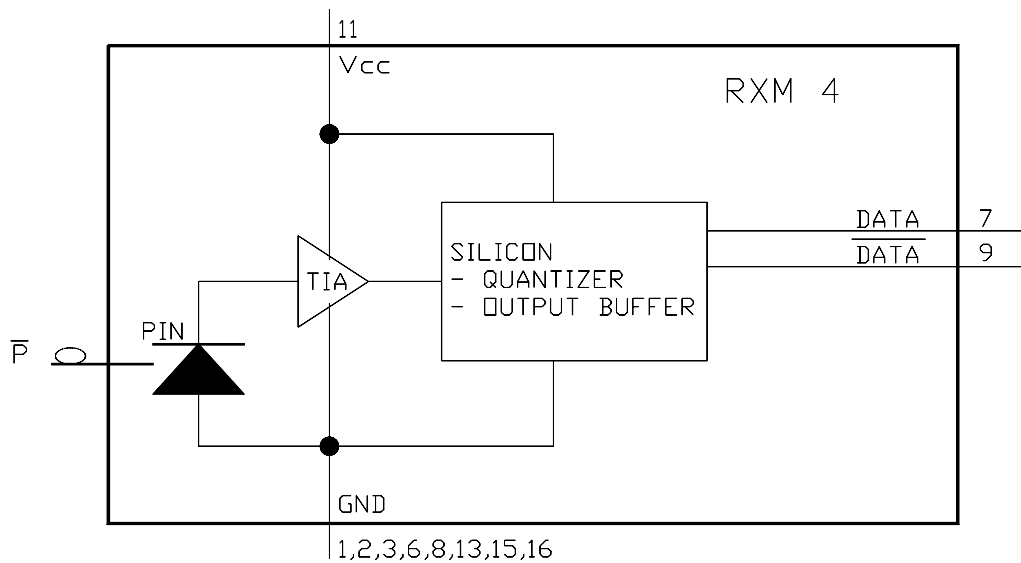

NO CONNECT:  
4,5,10,12,14,17,18,19,20

Figure 1. RXM-4 Functional Block Diagram

# RXM-4 Fiber Optic High Sensitivity Receiver Module

## Product Data Sheet

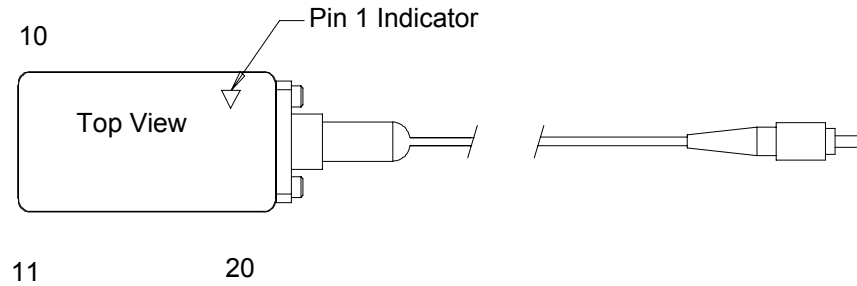

**Figure 2. Pin Diagram (Top View)**

**Table 1. Pin Function**

Pin	Symbol	Function
7	Data	PECL Data Output.
9	Data	PECL Complementary Data Output.
11	V <sub>CC</sub>	5 Volt Supply Voltage.
1,2,3,6,8,13,15,16	GND	Ground.
4,5,10,12,14,17,18,19,20	NC	No Connection.

## Absolute Maximum Ratings

Absolute maximum ratings are provided here as worst case and short duration exposure conditions only. Exposure to conditions more severe than the Absolute Maximum Ratings may result in permanent damage. Exposure to conditions at the Absolute

Maximum Ratings for extended periods may also adversely affect device performance or reliability. Functional operation of the device is not implied at these conditions.

**Table 2. Absolute Maximum Ratings**

Parameter	Symbol	Minimum	Maximum	Units
Storage Temperature Range	T <sub>S</sub>	-40	85	°C
Supply Voltage	V <sub>CC</sub>	0	+6	V
Lead Soldering Conditions			250/10	°C/s

# RXM-4 Fiber Optic High Sensitivity Receiver Module

## Product Data Sheet

---

### Performance Characteristics

**Table 3. Electrical Performance**

Parameter	Symbol	Minimum	Typical	Maximum	Units
Input Signal Rate	$f_o$		4.096		Mb/s
Operating Temperature	$T_O$	0		+70	°C
Power Supply Voltage	$V_{CC}$	4.5	5.0	5.5	V
Power Supply Current	$I_{CC}$			200	mA
Data Output Levels <sup>1</sup>					
Low	$V_{OL}$	$V_{CC} - 1.95$		$V_{CC} - 1.63$	V
High	$V_{OH}$	$V_{CC} - 1.03$		$V_{CC} - 0.88$	V
Data Output Rise and Fall Times <sup>2</sup>	$T_R, T_F$	500		1700	ps

1. Measured with a load of  $R_L = 50\Omega$  to  $V_{CC} - 2V$ . See figures 3 and 4. ECL levels are specified for dc measurement, an additional tolerance of 50 mV should be included for dynamic measurements.

2. Measured at 20% to 80% levels, standard MC10H116 output levels.

**Table 4. Optical Performance**

Parameter	Symbol	Minimum	Typical	Maximum	Units
Minimum Average Sensitivity <sup>1</sup>	Sens.	-45.0			dBm
Maximum Optical Input <sup>1</sup>	$P_{MAX}$			-5.0	dBm
Input Wavelength	$\lambda$	1280		1580	nm

1. For a BER less than 1E-10. Measured using a  $2^{23} - 1$  pseudorandom word and a 50% average optical duty cycle and a 10 dB Extinction Ratio.

# RXM-4 Fiber Optic High Sensitivity Receiver Module

## Product Data Sheet

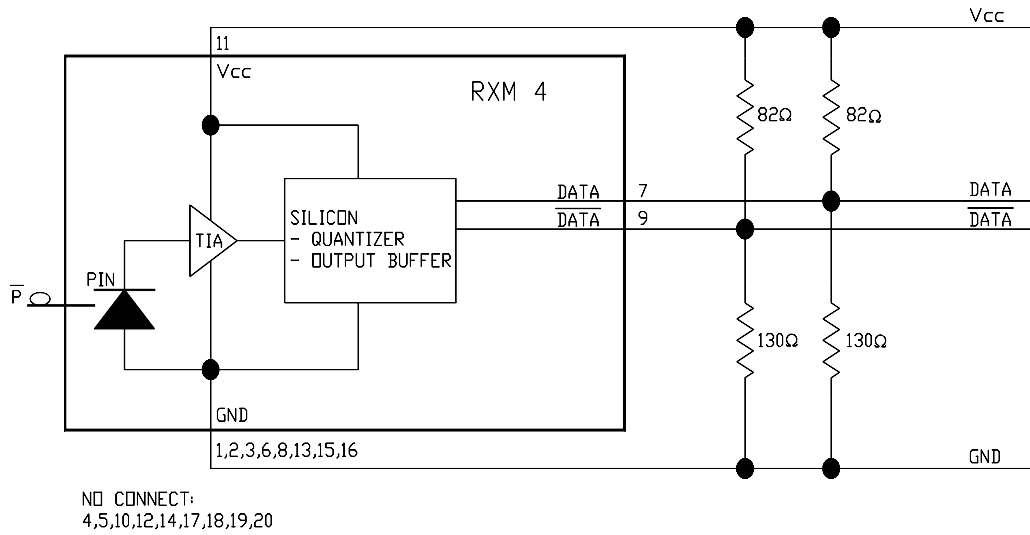

Figure 3. PECL Interface

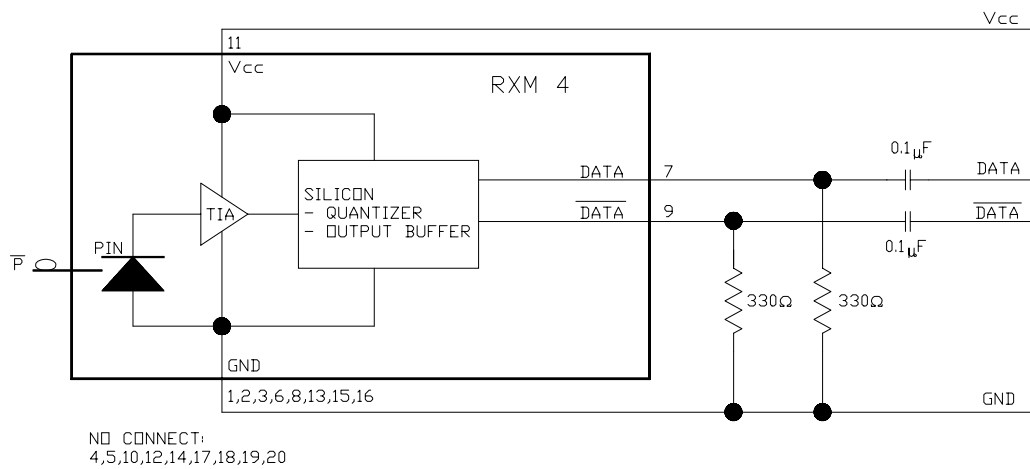

Figure 4. ECL (AC Coupled) Interface

# RXM-4 Fiber Optic High Sensitivity Receiver Module

## Product Data Sheet

---

### Qualification

The RXM-4 has been designed to comply with the requirements of Bellcore specifications GR-468-CORE, Reliability Assurance for Optoelectronic Devices and will be subject to a complete qualification test plan to demonstrate full compliance. All of the technologies used in the assembly of the module represent standard microelectronic and

optical technologies that are used in similar products, and have extensive field reliability data. All components and technologies used in the optical receiver are backed by qualification data covering mechanical and environmental tests along with accelerated life tests. Typical tests, test conditions and sample sizes are listed below.

**Table 5. Qualification Plan**

Test	Test Method	Sample Size
Physical Dimensions	MIL-STD-883, Method 2016	11
Mechanical Shock	MIL-STD-883, Method 2002, Test B	11
Vibration, variable frequency	MIL-STD-883, Method 2007, Test A	11
Lead Solderability	MIL-STD-883, Method 2003	22 leads
Lead Integrity	MIL-STD-883, Method 2004	15 leads
Temperature Cycling	-40°C/85°C, 300 cycles	11
High Temperature Aging	85°C under bias, 2000 hours	11
Damp Bake	85°C/85% RH/ 1000 hrs	11
Low Temperature Storage	-40°C, 168 hours	11
ESD	MIL-STD 883, Method 3015	3
Destructive Bond Pull	MIL-STD-883, Method 2011	40

**Table 6. Optical Fiber Characteristics**

Parameter	Minimum	Typical	Maximum	Units
Fiber Length		1000		mm
Fiber Core		62.5		µm
Fiber Buffer		900		µm

# RXM-4 Fiber Optic High Sensitivity Receiver Module

## Product Data Sheet

### Outline Diagram

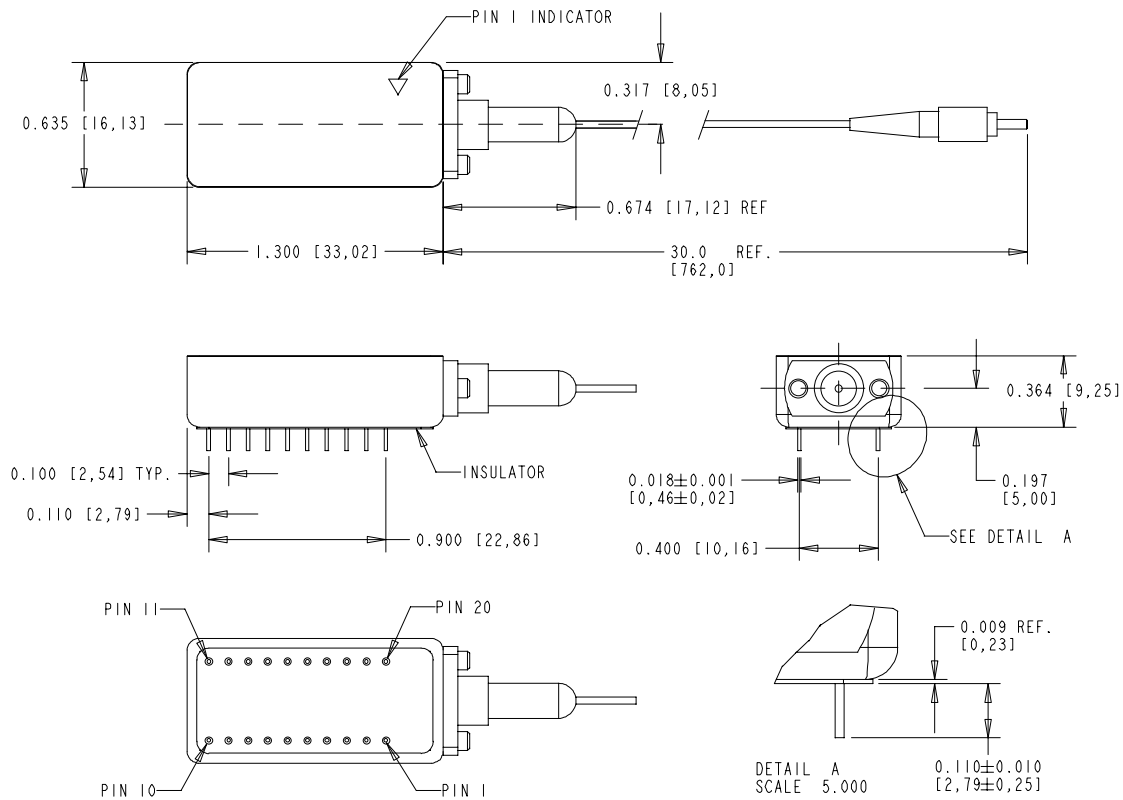

Figure 5. Outline Diagram

### Ordering Information

Standard modules are built with 62.5um MM fiber, with an outer jacket diameter of 900um. Alternative fiber type, connector type and fiber lengths are available upon request. Contact factory for specific details.

Table 7. Part Numbers

Fiber-Optic Connector <sup>1</sup>	Model Number	VI Code Number
LC	RXM-4L	330006917
ST	RXM-4B	330001825

1. Other connectors or fiber requirements are available to meet specific application requirements.

# RXM-4 Fiber Optic High Sensitivity Receiver Module

## Product Data Sheet

---

Notes:



**VECTRON**  
INTERNATIONAL

A  TECHNOLOGIES COMPANY

USA: Vectron International • 166 Glover Avenue, Norwalk, CT 06856 • Tel: 1-88-VECTRON-1 • Fax: 1-888-FAX-VECTRON  
EUROPE: In Denmark, Finland, Ireland, Italy, Israel, Norway, Spain, UK: Tel: 44 (0) 1703 766 288 • Fax: 44 (0) 1703 766 822  
In Austria, Belgium, France, Germany, Luxemburg, Netherlands, Sweden, Switzerland: Tel: 49(0)7263 6480 • Fax: 49(0)7263 6196  
ASIA: In China, Taiwan, Japan: Tel: 01 603 598 0070 • Fax: 01 603 598 0075  
In Korea, Singapore, Australia, India: Tel: 01 203 853 4433 • Fax: 01 203 853 1423

*Vectron International, Inc. reserves the right to make changes to the product(s) and/or information contained herein without notice. No liability is assumed as a result of their use or application. No rights under any patent accompany the sale of any such product(s) or information.*