

MATERIALS AND FINISHES

BODY, FERRULE, CAP: BRASS
PLATED: SEE TABLE

CENTER CONTACT: BERYLLIUM COPPER
PLATED: SEE TABLE

INSULATOR: TEFLON

RETAINING RING: BERYLLIUM COPPER
PLATED: SEE TABLE

PRESS INSULATOR
AND CAP INTO BODY
AS SHOWN

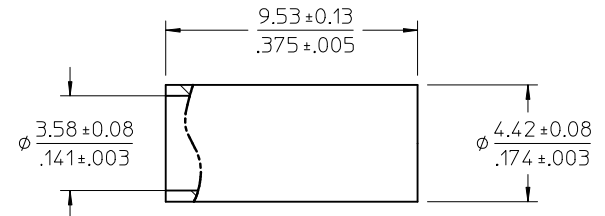
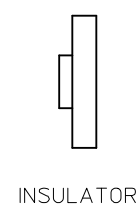
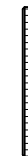
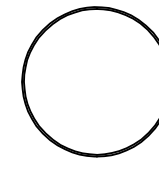
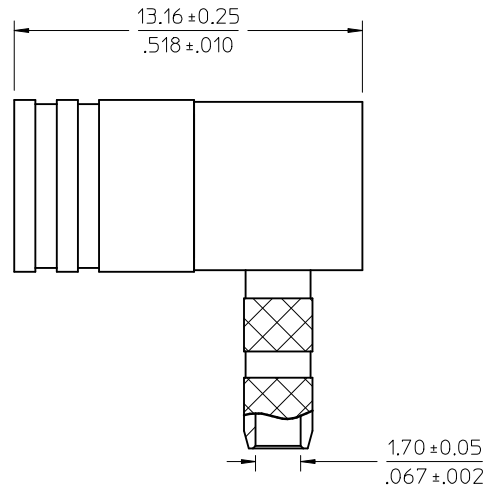
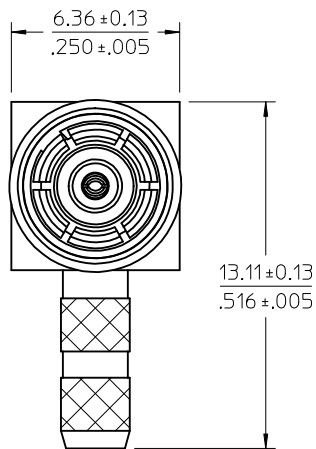
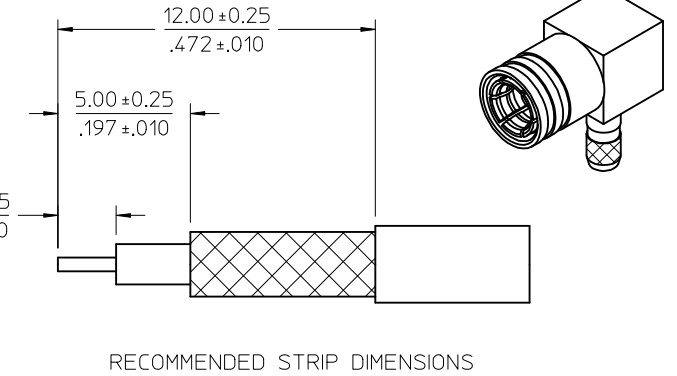
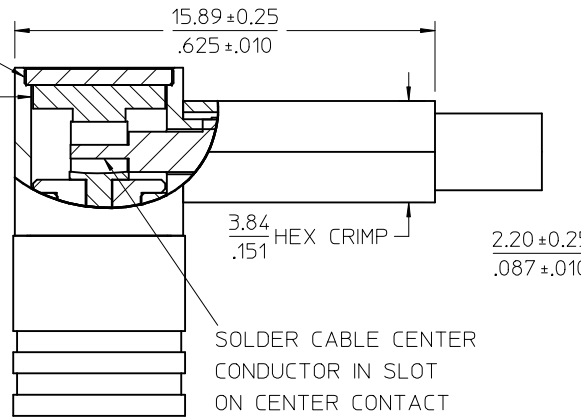

73404-0294	SAME AS 73404-0292 WITHOUT CAP, INSULATOR, FERRULE
73404-0293	Au OVER Ni (30 MICROINCH)/Au OVER Ni (30 MICROINCH)/NICKEL
73404-0292	NICKEL / GOLD (30 MICROINCH) OVER NICKEL / NICKEL
73404-0291	GOLD OVER NICKEL / GOLD OVER NICKEL / NONE
73404-0290	NICKEL / GOLD OVER NICKEL / NONE
PART NO.	BODY, FERRULE, CAP/CONTACT/RETAINING RING

PS-89675-3540	PRODUCT SPECIFICATION
SPECIFICATION	DESCRIPTION

CHG: REVISED STRIPS FOR IPC COMPLIANCE.	EC NO: URF-2012-0703	QUALITY SYMBOLS ▽=0 ▽=0	GENERAL TOLERANCES (UNLESS SPECIFIED)	DIMENSION STYLE		SCALE	DESIGN UNITS	THIRD ANGLE PROJECTION
	DRWIN:ROBERTSON 2012/05/23			IN/MM	INCH			
CHKD:SSS 2012/05/23	APPR:JWIENER 2012/05/24	DESCRIPTION		DRAWN BY	DATE	TITLE	SMB PLUG RA RD316	
				CHECKED BY	DATE		50 OHMS	
				SSS	2012/05/23		EWR-2444 SMB-PC/RA	
				APPROVED BY	DATE		MOLEX INCORPORATED	
				JWIENER	2000/10/12		SD-73404-029	
				MATERIAL NO.		DOCUMENT NO.	SHEET NO.	
							1 OF 1	
							THIS DRAWING CONTAINS INFORMATION THAT IS PROPRIETARY TO MOLEX INCORPORATED AND SHOULD NOT BE USED WITHOUT WRITTEN PERMISSION	