

Triple Inverter (unbuffer)

FEATURES

- High output drive : $\pm 8\text{mA}(\text{min.}) @V_{CC}=4.5\text{V}$.
- Super high speed operation : $\text{tpd } 3.4\text{ns}(\text{typ.}) @V_{CC}=5\text{V}, 50\text{pF}$.
- Operation voltage range : $V_{CC(\text{opr})}=1.65\sim 5.5\text{V}$.

MAXIMUM RATINGS (Ta=25)

CHARACTERISTIC	SYMBOL	RATING	UNIT
Power Supply Voltage	V_{CC}	-0.5~7	V
DC Input Voltage	V_{IN}	-0.5~7	V
DC Output Voltage	V_{OUT}	-0.5~7	V
Input Diode Current	I_{IK}	-50	mA
Output Diode Current	I_{OK}	± 50	mA
DC Output Current	I_{OL}	± 50	mA
DC V_{CC} /ground Current	I_{CC}	± 100	mA
Power Dissipation	P_D	20	mW
Storage Temperature Range	T_{stg}	-65 ~ 150	°C
Lead Temperature (10s)	T_{Lr}	260	°C

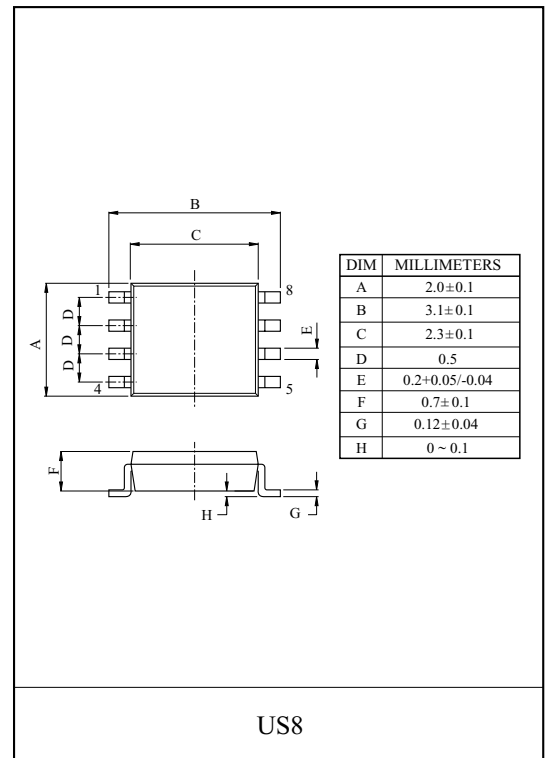

MARKING

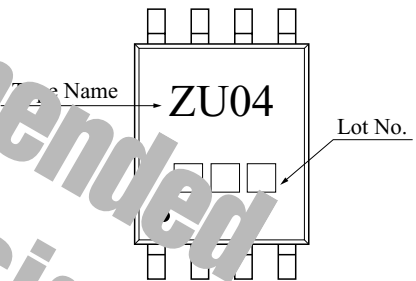

Logic Diagram

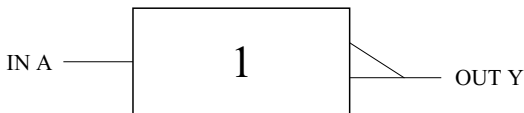

Truth Table

A	Y
L	H
H	L

PIN CONNECTION(TOP VIEW)

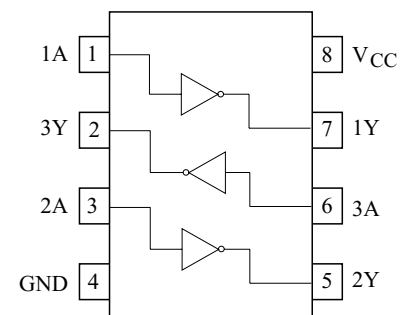

KIC7WZU04FK

Recommended Operating Conditions

CHARACTERISTIC	SYMBOL	RATING	UNIT
Supply Voltage	V_{CC}	1.8~5.5	V
		1.5~5.5 (Note1)	
Input Voltage	V_{IN}	0~5.5	V
Output Voltage	V_{OUT}	0~5.5 (Note2)	V
		0~ V_{CC} (Note3)	
Operating Temperature	T_{opr}	-40~85	

Note1 : Data retention only. Note2 : $V_{CC}=0V$. Note3 : High or low state

ELECTRICAL CHARACTERISTICS

DC Characteristics

CHARACTERISTIC		SYMBOL	TEST CONDITION	$T_a=25$			$T_a=-40\sim 85$		UNIT			
				$V_{CC}(V)$	MIN.	TYP.	MAX.	MIN.		MAX.		
Input Voltage	High Level	V_{IH}	-	1.8~2.7	$0.85 \times V_{CC}$	-	-	$0.85 \times V_{CC}$	V			
				3.0~5.5	$0.8 \times V_{CC}$	-	-	$0.8 \times V_{CC}$				
	Low Level	V_{IL}	-	1.8~2.7	-	-	$0.15 \times V_{CC}$	$0.15 \times V_{CC}$				
				3.0~5.5	-	-	$0.2 \times V_{CC}$	$0.3 \times V_{CC}$				
Output Voltage	High Level	V_{OH}	$V_{IN}=V_{IH}$ $I_{OH}=-10\mu A$	1.65	1.55	1.65	-	1.55	-	V		
				2.3	1.6	1.79	-	1.6	-			
				3.0	1.7	2.29	-	2.1	-			
				4.5	1.8	2.99	-	2.7	-			
				$V_{IN}=GND$	$I_{OH}=-2mA$	1.65	1.26	1.5	-		1.26	-
					$I_{OH}=-2mA$	2.3	1.9	2.15	-		1.9	-
					$I_{OH}=-4mA$	3.0	2.0	2.82	-		2.4	-
					$I_{OH}=-6mA$	3.0	2.3	2.73	-		2.7	-
	Low Level	V_{OL}	$V_{IN}=V_{IH}$ $I_{OL}=100\mu A$	1.65	-	0.0	0.2	-	0.2			
				1.8	-	0.01	0.2	-	0.2			
				2.3	-	0.01	0.2	-	0.2			
				3.0	-	0.01	0.3	-	0.3			
				4.5	-	0.01	0.5	-	0.5			
				$V_{IN}=V_{CC}$	$I_{OL}=2mA$	1.65	-	0.10	0.24		-	0.24
$I_{OL}=2mA$	2.3	-	0.12		0.3	-	0.3					
$I_{OL}=4mA$	3.0	-	0.19		0.4	-	0.4					
$I_{OL}=6mA$	3.0	-	0.29		0.55	-	0.55					
	$I_{OL}=8mA$	4.5	-	0.29	0.55	-	0.55					
Input Leakage Current		I_{IN}	$V_{IN}=5.5V, GND$	0~5.5	-	-	± 0.1	-	μA			
Quiescent Supply Current		I_{CC}	$V_{IN}=5.5V, GND$	1.65~5.5	-	-	1.0	-	10 μA			
Peak Supply Current in Analog Operation		I_{CCPEAK}	$V_{OUT}=Open$ $V_{IN}=Adjust\ for\ Peak\ I_{CC}\ Current$	1.8	-	0.2	-	-	-	mA		
				2.5	-	2	-	-				
				3.3	-	5	-	-				
				5.0	-	15	-	-				

KIC7WZU04FK

AC Characteristics

CHARACTERISTIC	SYMBOL	TEST CONDITION	Ta=25			Ta=-40~85		UNIT	
			V _{CC} (V)	MIN.	TYP.	MAX.	MIN.		MAX.
Propagation Delay (Figures 1,3)	t _{PLH} t _{PHL}	C _L =15pF, R _L =1M	1.65	1.5	5.5	9.8	1.5	11.0	ns
			1.8	1.5	4.6	8.1	1.5	8.9	
			2.5 ± 0.2	1.2	3.3	5.7	1.2	6.3	
			3.3 ± 0.3	0.8	2.7	4.1	0.8	4.5	
	t _{PLH} t _{PHL}	C _L =50pF, R _L =500	3.3 ± 0.3	1.2	4.0	6.4	1.2	7.0	ns
			5.0 ± 0.5	0.8	3.4	5.6	0.8	6.2	
Input Capacitance	C _{IN}		0	-	3	-	-	pF	
Power Dissipation Capacitance (Figure 2)	C _{PD}	(Note)	3.3	-	3.5	-	-	-	pF
			5.0	-	5.5	-	-	-	

Note : C_{PD} is defined as the value of the internal equivalent capacitance which is derived from dynamic operating current consumption (I_{CCD}) at no output loading and operating at 50% duty cycle. (See Figure 2.) C_{PD} is related to I_{CCD} dynamic operating current by the expression : I_{CCD}=C_{PD} · V_{CC} · f_{IN}+I_{CC}

AC Loading and Waveforms

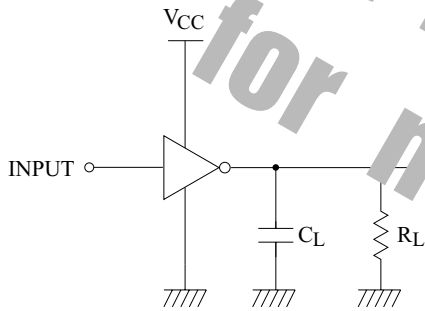

C_L includes load and stray capacitance
Input PRR=1.0MHz ; t_w=500ns

FIGURE 1. AC Test Circuit

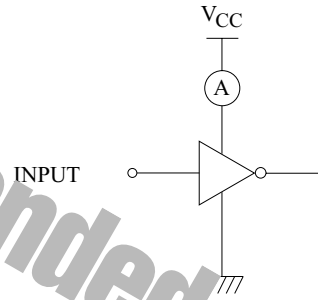

Input=AC Waveform ; t_r=t_f=1.8ns
PRR=variable ; Duty Cycle=50%

FIGURE 2. ICCD Test Circuit

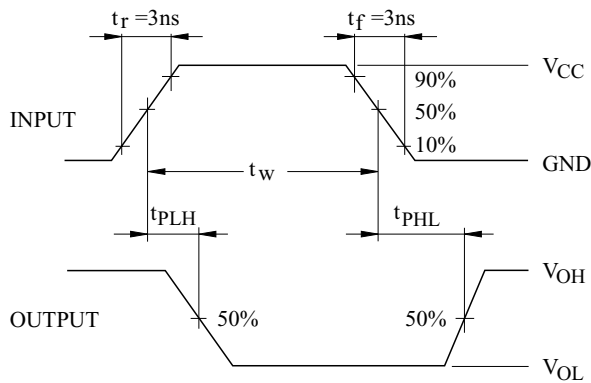

FIGURE 3. AC Waveforms