

# Compact Fluorescent Electronic Dimming Ballast Controller

## GENERAL DESCRIPTION

The ML4836 is a complete solution for a dimmable or a non-dimmable high efficiency electronic ballast especially tailored for a compact fluorescent lamp (CFL). The Bi-CMOS ML4836 contains controllers for dimming ballast with end-of-life detection capability.

The ballast controller section provides for programmable starting sequence with individual adjustable preheat and lamp out-of-socket interrupt times. The ML4836 provides latch type shut down comparator for ballast controllers in the event of end-of-life for the CFL.

## FEATURES

- Programmable start scenario for rapid/instant start lamps
- Triple frequency control network for dimming or starting to handle various lamp sizes
- Programmable restart for lamp out condition to reduce ballast heating.
- Internal over-temperature shutdown
- Low start-up current; < 0.55mA

(\* Indicates Part is End Of Life as of July 1, 2000)

## BLOCK DIAGRAM

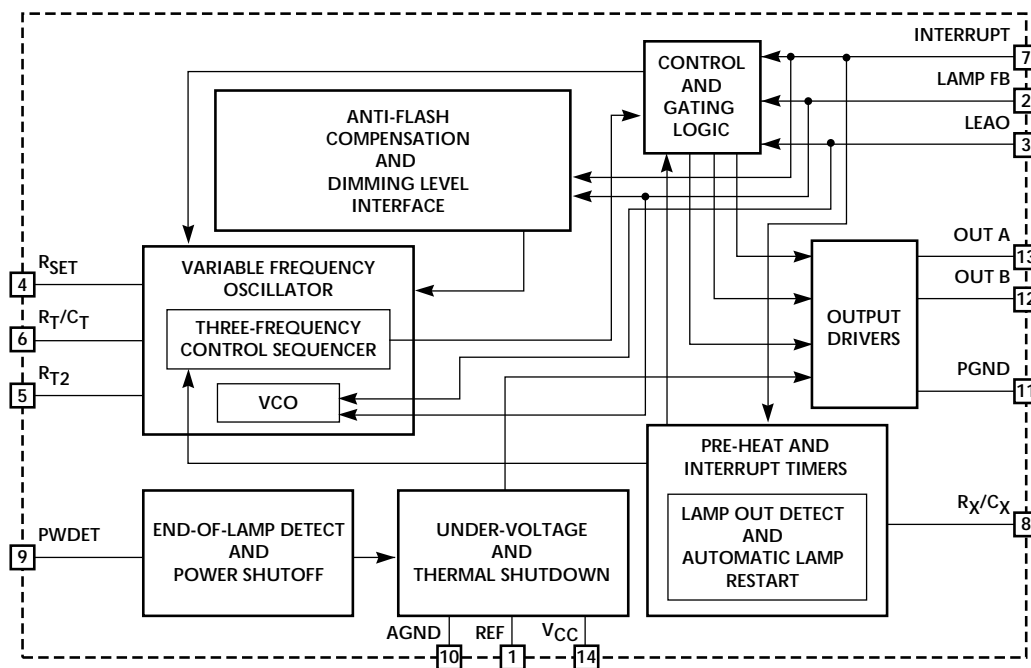

## PIN CONFIGURATION

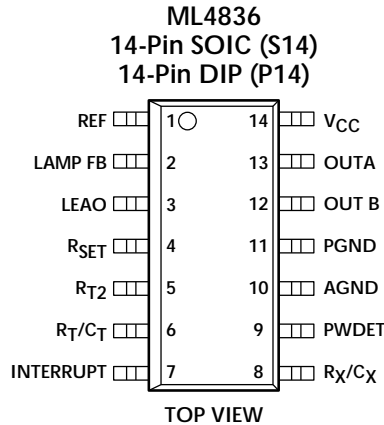

## PIN DESCRIPTION

PIN	NAME	FUNCTION	PIN	NAME	FUNCTION
1	REF	Buffered output for the 7.5V reference	7	INTERRUPT	Input used for lamp-out detection and restart. A voltage less than 1V will reset the IC and cause a restart after a programmable interval.
2	LAMP FB	Inverting input of the lamp error amplifier, used to sense and regulate lamp arc current. Also the input node for dimmable control.	8	R <sub>X</sub> /C <sub>X</sub>	Sets the timing for preheat and interrupt.
3	LEAO	Output of the lamp current error transconductance amplifier used for lamp current loop compensation	9	PWDET	Lamp output power detection
4	R <sub>SET</sub>	External resistor which SETS oscillator F <sub>MAX</sub> , and R <sub>X</sub> /C <sub>X</sub> charging current	10	AGND	Analog ground
5	R <sub>T2</sub>	Oscillator timing component to set start frequency	11	PGND	Power ground.
6	R <sub>T</sub> /C <sub>T</sub>	Oscillator timing components	12	OUT B	Ballast MOSFET driver output
			13	OUT A	Ballast MOSFET driver output
			14	V <sub>CC</sub>	Positive supply voltage

## ABSOLUTE MAXIMUM RATINGS

Absolute maximum ratings are those values beyond which the device could be permanently damaged. Absolute maximum ratings are stress ratings only and functional device operation is not implied.

Supply Current ( $I_{CC}$ ) .....	50mA
Output Current, Source or Sink (OUT A, OUT B) DC .....	250mA
PIFB Input Voltage .....	-3V to 2V
Maximum Forced Voltage (PEAO, LEAO) .....	-0.3V to 7.7V
Maximum Forced Current (LEAO) .....	$\pm 20$ mA

Junction Temperature .....	150°C
Storage Temperature Range .....	-65°C to 150°C
Lead Temperature (Soldering, 10 sec) .....	260°C
Thermal Resistance ( $\theta_{JA}$ )	
ML4836CP .....	C/W
ML4836CS .....	C/W

## OPERATING CONDITIONS

Temperature Range .....	0°C to 85°C
-------------------------	-------------

## ELECTRICAL CHARACTERISTICS

Unless otherwise specified,  $V_{CC} = V_{CCZ} - 0.5V$ ,  $R_{SET} = 11.8k\Omega$ ,  $R_T = 14.7k\Omega$ ,  $R_{T2} = 53.6k\Omega$ ,  $C_T = 1.5nF$ ,  $T_A =$  Operating Temperature Range (Note 1)

SYMBOL	PARAMETER	CONDITIONS	MIN	TYP	MAX	UNITS
<b>LAMP CURRENT AMPLIFIER (LAMP FB, LEAO)</b>						
	Input Bias Current			-0.3	-1.0	$\mu A$
	Small Signal Transconductance		35	75	105	$\mu S$
	Input Bias Voltage		-0.3		5.0	V
	Output Low	LAMP FB = 3V, $R_L = \infty$		0.2	0.4	V
	Output High	LAMP FB = 2V, $R_L = \infty$	7.1	7.5		V
	Source Current	LAMP FB = 0V, LEAO = 6V	-80	-220		$\mu A$
	Sink Current	LAMP FB = 5V, LEAO = 0.3V	80	220		$\mu A$

### OSCILLATOR

	Initial Accuracy ( $F_{MIN}$ )	$T_A = 25^\circ C$	39.2	40	40.8	kHz
	Total Variation ( $F_{MIN}$ )	Line, Temperature	39.2		40.8	kHz
	Initial Accuracy (START)	$T_A = 25^\circ C$	49	50	51	kHz
	Total Variation (START)	Line, Temperature	49		51	kHz
	Ramp Valley to Peak			2.6		V
	Initial Accuracy (Preheat)	$T_A = 25^\circ C$	60.8	64	67.2	kHz
	Total Variation (Preheat)	Line, Temperature	60.8	64	67.2	kHz
	$C_T$ Discharge Current	$V_{RTCT} = 2.5V$	6.0	7.5	9.0	mA
	Output Drive Deadtime	$C_T = 1.5nF$		0.7		us

### REFERENCE BUFFER

	Output Voltage	$T_A = 25^\circ C, I_O = 0mA$	7.4	7.5	7.6	V
	Line Regulation	$V_{CCZ} - 4V < V_{CC} < V_{CCZ} - 0.5V$		10	25	mV
	Load Regulation	$1mA < I_O < 10mA$		2	15	mV
	Temperature Stability			0.4		%
	Total Variation	Line, Load, Temperature	7.35		7.65	V
	Long Term Stability	$T_j = 125^\circ C, 1000$ hrs		5		mV

## ELECTRICAL CHARACTERISTICS (Continued)

SYMBOL	PARAMETER	CONDITIONS	MIN	TYP	MAX	UNITS
<b>REFERENCE BUFFER (Continued)</b>						
	Short Circuit Current			40		mA
	R <sub>SET</sub> Voltage		2.4	2.5	2.6	V
<b>PREHEAT AND INTERRUPT TIMER (R<sub>X</sub> = 346kΩ, C<sub>X</sub> = 10μF)</b>						
	R <sub>X</sub> /C <sub>X</sub> Charging Current		-48	-52	-56	μA
	R <sub>X</sub> /C <sub>X</sub> Open Circuit Voltage		0.4	0.7	1.0	V
	R <sub>X</sub> /C <sub>X</sub> Maximum Voltage		7.0	7.3	7.8	V
	Preheat Lower Threshold		1.6	1.75	1.9	V
	Preheat Upper Threshold		4.4	4.65	4.9	V
	Start Period End Threshold		6.2	6.6	6.9	V
	Interrupt Disable Threshold		1.1	1.25	1.4	V
	Hysteresis		0.16	0.26	0.36	V
	Input Bias Current				1	μA
<b>POWER SHUTDOWN</b>						
	Power Shutdown Voltage		0.9	1.0	1.1	V
<b>OUTPUTS (OUT A, OUT B, PFC OUT)</b>						
	Output Voltage Low	I <sub>OUT</sub> = 20mA		0.1	0.2	V
		I <sub>OUT</sub> = 200mA		1.0	2.0	V
	Output Voltage High	I <sub>OUT</sub> = 20mA	V <sub>CC</sub> - 0.2	V <sub>CC</sub> - 0.1		V
	Output Voltage High	I <sub>OUT</sub> = 200mA	V <sub>CC</sub> - 2.0	V <sub>CC</sub> - 1.0		V
	Output Voltage Low in UVLO	I <sub>OUT</sub> = 20mA, V <sub>CC</sub> < V <sub>CC START</sub>			0.2	V
	Output Rise and Fall Time	CL = 1000pF		50		ns
<b>UNDER VOLTAGE LOCKOUT AND BIAS CIRCUITS</b>						
	IC Shunt Voltage (V <sub>CCZ</sub> )	ICC = 15mA	14.0	14.8	15.5	V
	Start-up Threshold (V <sub>CC START</sub> )		V <sub>CCZ</sub> - 1.5	V <sub>CCZ</sub> - 1.0	V <sub>CCZ</sub> - 0.5	V
	Hysteresis		3.0	3.7	4.4	V
	Start-up Current	V <sub>CC START</sub> - 0.2V		350	550	μA
	Interrupt Current	(V <sub>CCZ</sub> - 0.5V), INTERRUPT = 0V		500	750	μA
	Operating Current	(V <sub>CCZ</sub> - 0.5V)		4.0	8.0	mA
	Shutdown Temperature			140		°C
	Hysteresis			30		°C

Note 1: Limits are guaranteed by 100% testing, sampling, or correlation with worst case test conditions.

## FUNCTIONAL DESCRIPTION

The ML4836 consists of flexible ballast control section. Start-up and lamp-out retry timing are controlled by the selection of external timing components, allowing for control of a wide variety of different lamp types. The ballast section controls the lamp power using frequency modulation (FM) with additional programmability provided to adjust the VCO frequency range. This allows for the IC to be used with a variety of different output networks. Figure 1 depicts a detailed block diagram of ML4836.

The ML4836 provides several safety features. See the corresponding sections for more details:

- End-of-lamp life detection to detect EOL and shut-off lamps; See End Of Life Section.
- Thermal shutdown for temperature sensing extremes; See IC Bias, Under-Voltage Lockout and Thermal Shutdown Section.
- Relamping starting with anti-flash for programmable restart for lamp out conditions while minimizing “flashing” when powering from full power to dimming levels; See Starting, Re-Start, Preheat and Interrupt Section

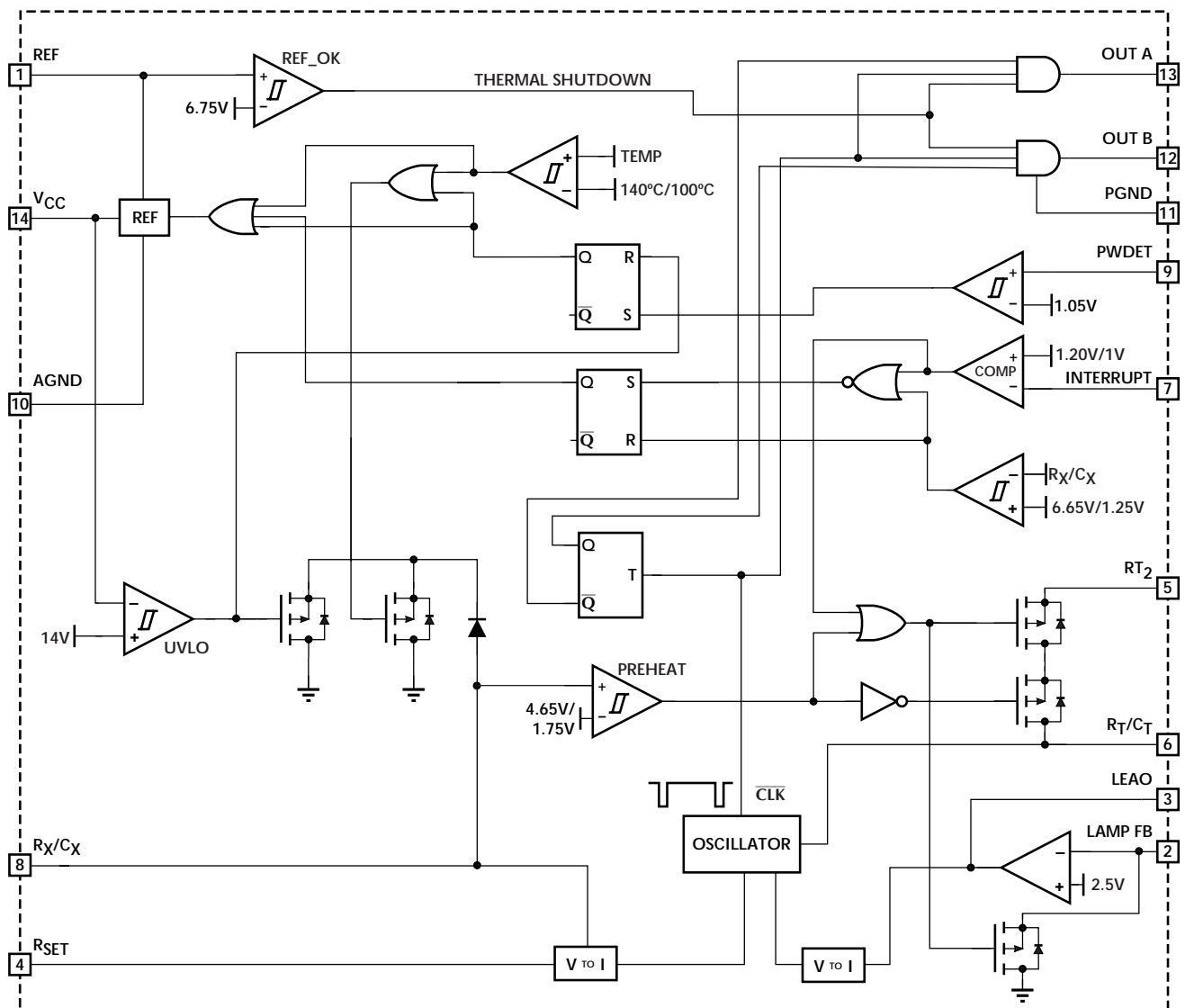

Figure 1. Detailed Block Diagram

## FUNCTIONAL DESCRIPTION (Continued)

The ML4836 implements a triple frequency operation scheme: programmable three-frequency sequence for pre-heat, ignition, and dimming, that extends lamp life, simplifies lamp network design, and starts lamps at any dimming level without flashing. This addresses the need for a high-Q network for starting sequence and low-Q network for operation, minimizing parasitic losses and improving overall power efficiency. The values for the pre-heat, start, operation, and restart can be programmed or selected (Figure 2).

### TRANSCONDUCTANCE AMPLIFIERS

The Lamp voltage feedback amplifier is implemented as an operational transconductance amplifier. It is designed

to have low small signal forward transconductance such that a large value of load resistor ( $R_1$ ) and a low value ceramic capacitor ( $<1\mu\text{F}$ ) can be used for AC coupling ( $C_1$ ) in the frequency compensation network. The compensation network shown in Figure 5 will introduce a zero and a pole at:

$$f_z = \frac{1}{2\pi R_1 C_1} \quad f_p = \frac{1}{2\pi R_1 C_2} \quad (2)$$

Figure 3 shows the output configuration for the operational transconductance amplifiers.

A DC path to ground or  $V_{CC}$  at the output of the transconductance amplifiers will introduce an offset error.

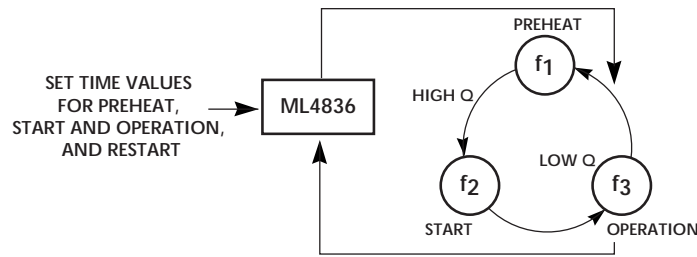

Figure 2. Three Frequency Design Model

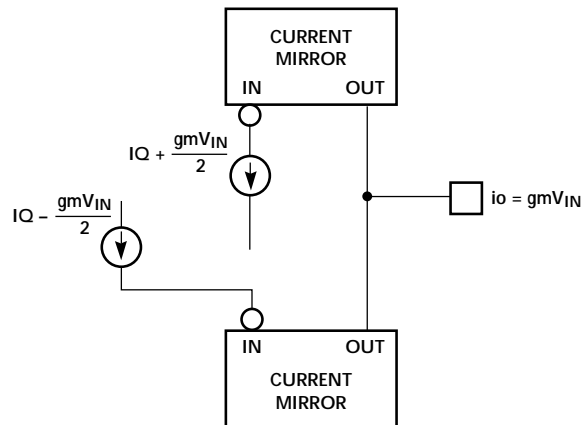

Figure 3. Output Configuration

## FUNCTIONAL DESCRIPTION (Continued)

The magnitude of the offset voltage that will appear at the input is given by  $V_{OS} = i_o/g_m$ . For an  $i_o$  of  $1\mu\text{A}$  and a  $g_m$  of  $0.05\mu\text{W}$  the input referred offset will be  $20\text{mV}$ . Capacitor C1 as shown in Figure 4 is used to block the DC current to minimize the adverse effect of offsets.

Slew rate enhancement is incorporated into all of the operational transconductance amplifiers in the ML4836. This improves the recovery of the circuit in response to power up and transient conditions. The response to large signals will be somewhat non-linear as the transconductance amplifiers change from their low to high transconductance mode, as illustrated in Figure 5.

## END OF LAMP LIFE

At the end of a lamp's life when the emissive material is depleted, the arc current is rectified and high voltage occurs across the lamp near the depleted cathode. The ballast acts as a constant current source so power is dissipated near the depleted cathode which can lead to arcing and bulb cracking. Compact fluorescent lamps are more prone to cracking or shattering because their small diameter can't dissipate as much heat as the larger linear lamps. Compact fluorescents also present more of a safety hazard since they are usually used in downlighting systems without reflector covers.

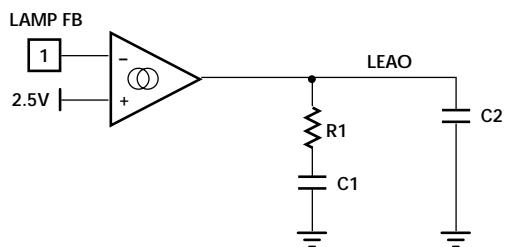

Figure 4. Compensation Network

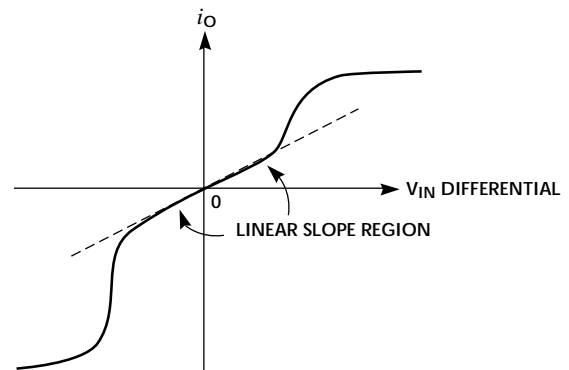

Figure 5. Transconductance Amplifier Characteristics

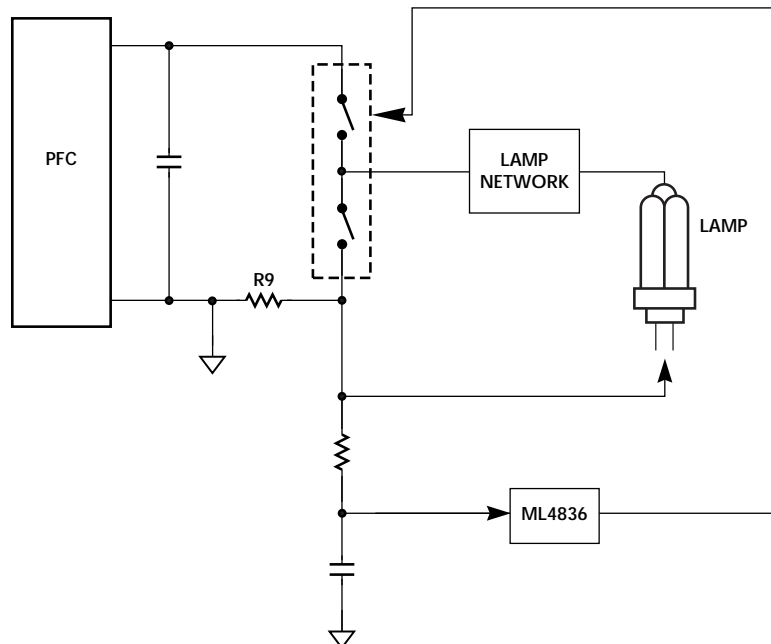

Figure 6. Simplified Model of ML4836 EOL Functionality

## FUNCTIONAL DESCRIPTION (Continued)

### EOL and the ML4836

The ML4836 uses a circuit that creates a DC voltage representative of the power supplied to the lamps through the inverter when use in conjunction with PFC. This voltage is used by the ML4836 to latch off the ballast when it exceeds an internal threshold. An external resistor can be used as the "EOL latch resistor" to set the power level trip point, as shown in by R9 in Figure 6.

### BALLAST OUTPUT SECTION

The IC controls output power to the lamps via frequency modulation with non-overlapping conduction. This means

that both ballast output drivers will be low during the discharging time  $t_{DIS}$  of the oscillator capacitor  $C_T$ .

### OSCILLATOR

The VCO frequency ranges are controlled by the output of the LFB amplifier ( $R_{SET}$ ). As lamp current decreases, LFB OUT falls in voltage, causing the  $C_T$  charging current to increase, thereby causing the oscillator frequency to increase. Since the ballast output network attenuates high frequencies, the power to the lamp will be decreased. The oscillator frequency is determined by the following equations:

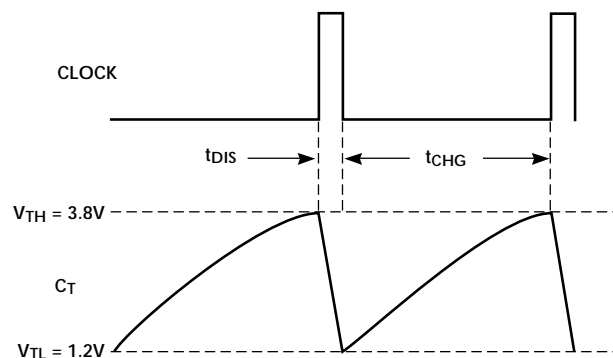
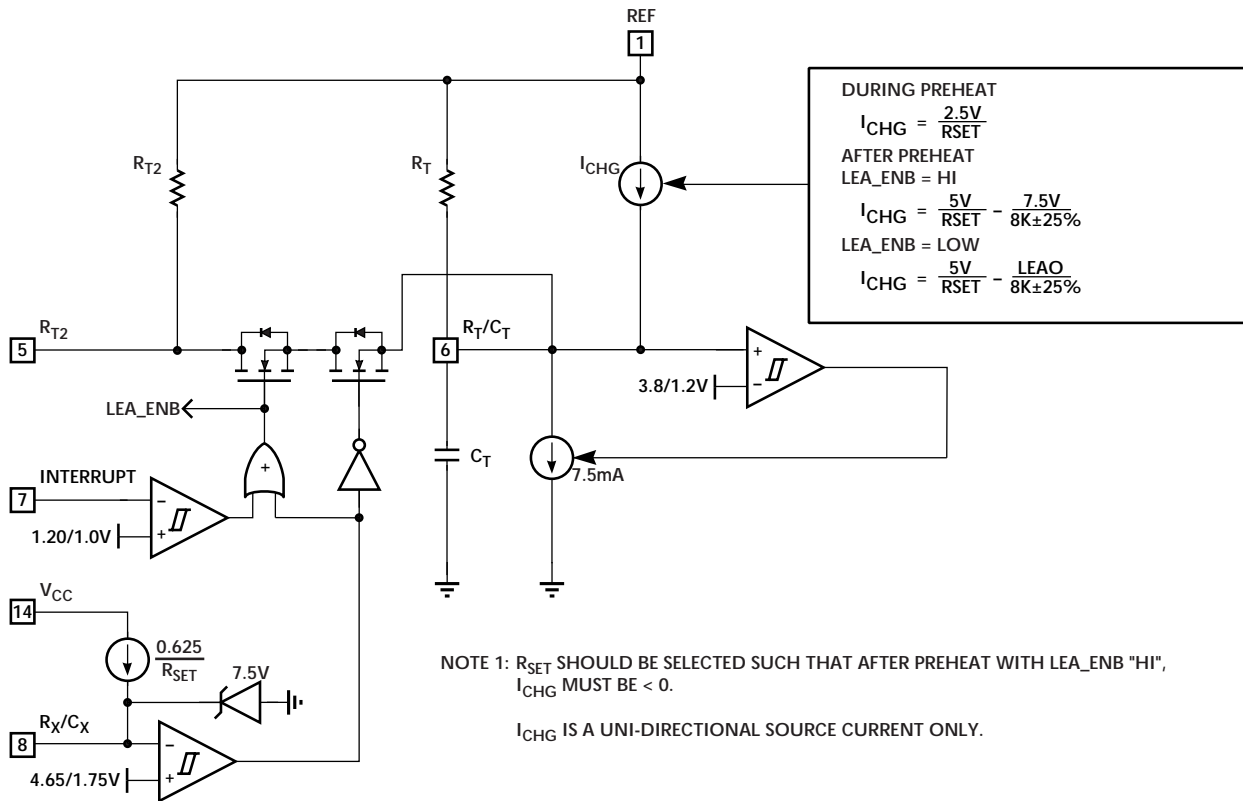

Figure 7. Oscillator Block Diagram and Timing



**FUNCTIONAL DESCRIPTION** (Continued)

$$F_{OSC} = \frac{1}{t_{CHG} + t_{DIS}} \quad (3)$$

and

$$t_{CHG} = R_T C_T \ln \left( \frac{V_{REF} + I_{CHG} \times R_T - V_{TL}}{V_{REF} + I_{CHG} \times R_T - V_{TH}} \right) \quad (4)$$

The oscillator's minimum frequency is set when  $I_{CHG} = 0$  where:

$$F_{MIN} \cong \frac{1}{0.54 \times R_T C_T} \quad (5)$$

The oscillator's start frequency can be expressed by:

$$F_{START} = \frac{1}{0.54 \times (R_T \parallel R_{T2}) \times C_T} \quad (5a)$$

Both equations assume that  $t_{CHG} \gg t_{DIS}$ .

When LFB OUT is high,  $I_{CHG} = 0$  and the minimum frequency occurs. The charging current varies according to two control inputs to the oscillator:

1. The output of the preheat timer

2. The voltage at LFB OUT (lamp feedback amplifier output)

In preheat condition, charging current is fixed at

$$I_{CHG(PREHEAT)} = \frac{2.5}{R_{SET}} \quad (6)$$

In running mode, charging current decreases as the voltage rises from 0V to  $V_{OH}$  at the LAMP FB amplifier.

The charging current behavior can be expressed as:

$$I_{CHG} = \frac{5V}{R_{SET}} - \frac{LEAO}{8k \pm 25\%} \quad (7)$$

The highest frequency is attained when  $I_{CHG}$  is highest, which is attained when voltage at LFB OUT is at 0V:

$$I_{CHG(0)} = \frac{5}{R_{SET}} \quad (8)$$

Highest lamp power, and lowest output frequency are attained when voltage at LFB OUT is at its maximum output voltage ( $V_{OH}$ ).

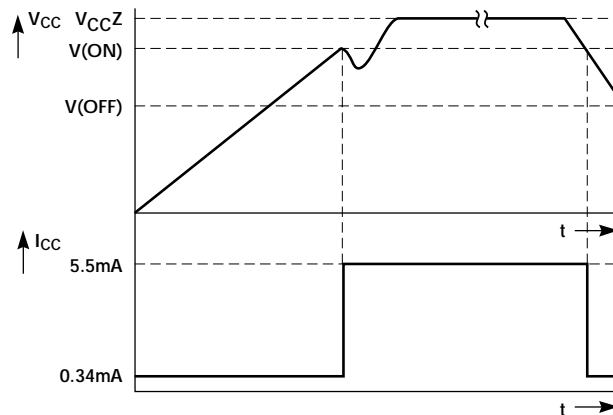

Figure 8. Typical  $V_{CC}$  and  $I_{CC}$  Waveforms when the ML4836 is Started with a Bleed Resistor from the Rectified AC Line and Bootstrapped from an Auxiliary Winding.

## FUNCTIONAL DESCRIPTION (Continued)

In this condition, the minimum operating frequency of the ballast is set per equation 5 above.

For the IC to be used effectively in dimming ballasts with higher Q output networks a larger  $C_T$  value and lower  $R_T$  value can be used, to yield a smaller frequency excursion over the control range (voltage at LFB OUT). The discharge current is set to 7.5mA. The operation of the oscillator is shown in Figure 7.

Assuming that  $I_{DIS} \gg I_{RT}$ :

$$t_{DIS(VCO)} \cong 600 \times C_T \quad (9)$$

### IC BIAS, UNDER-VOLTAGE LOCKOUT AND THERMAL SHUTDOWN

The IC includes a shunt clamp which will limit the voltage at  $V_{CC}$  to 14.5V ( $V_{CCZ}$ ). The IC should be fed with a current limited source, typically derived from the ballast transformer auxiliary winding. When  $V_{CC}$  is below  $V_{CCZ} - 1.1V$ , the IC draws less than 0.55mA of quiescent current and the outputs are off. This allows the IC to start using a “bleed resistor” from the rectified AC line. The ICC start-up condition is shown in Figure 7. To help reduce

ballast cost, the ML4836 includes a temperature sensor which will inhibit ballast operation if the IC’s junction temperature exceeds 140°C. In order to use this sensor in lieu of an external sensor, care should be taken when placing the IC to ensure that it is sensing temperature at the physically appropriate point in the ballast. The ML4836’s die temperature can be estimated with the following equation:

$$T_J \cong T_A + (P_D + 65^\circ C / W) \quad (10)$$

### STARTING, RE-START, PREHEAT AND INTERRUPT

The lamp starting scenario implemented in the ML4836 is designed to maximize lamp life and minimize ballast heating during lamp out conditions.

The circuit in Figure 9 controls the lamp starting scenarios: Filament preheat and lamp out interrupt.  $C_X$  is charged with a current of  $I_{R(SET)}/4$  and discharged through  $R_X$ . The voltage at  $C_X$  is initialized to 0.7V ( $V_{BE}$ ) at power up. The time for  $C_X$  to rise to 4.65V is the filament preheat time. During that time, the oscillator charging current ( $I_{CHG}$ ) is  $2.5/R_{SET}$ . This will produce a high frequency for filament preheat, but will not produce sufficient voltage to ignite the lamp or cause significant glow current.

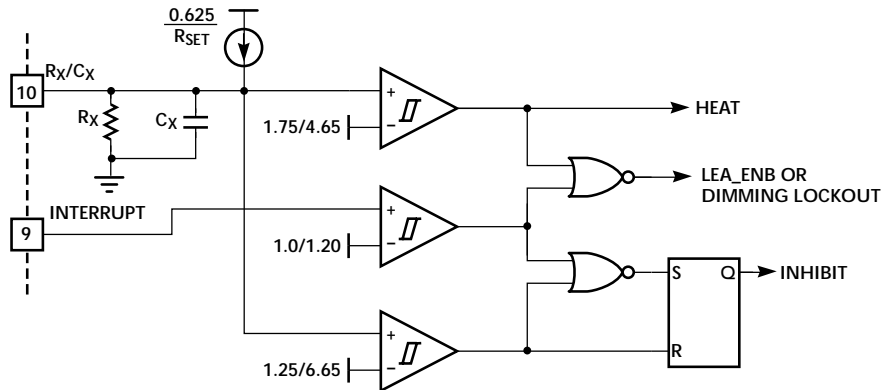

Figure 9. Lamp Preheat and Interrupt Timers

**FUNCTIONAL DESCRIPTION** (Continued)

After cathode heating, the inverter frequency drops to  $F_{START}$  causing a high voltage to appear to ignite the lamp. If lamp current is not detected when the lamp is supposed to have ignited, the  $C_X$  charging current is shut off and the inverter is inhibited until  $C_X$  is discharged by  $R_X$  to the 1.25V threshold. Shutting off the inverter in this manner prevents the inverter from generating excessive heat when the lamp fails to strike or is out of socket. Typically this time is set to be fairly long by choosing a large value of  $R_X$ .

LFB OUT is ignored by the oscillator until INTERRUPT is above 1.20V. The  $C_X$  pin is clamped to about 7.5V.

Care should also be taken not to turn on the VCCZ clamp

so as not to dissipate excessive power in the IC. This will cause the temp sensor to become active at a lower ambient temperature.

A summary of the operating frequencies in the various operating modes is shown below.

OPERATING MODE	OPERATING FREQUENCY
Preheat	$\frac{[F(MAX) \text{ to } F(MIN)]}{2}$
After Preheat	F(START)
Dimming Control	F(MIN) to F(MAX)

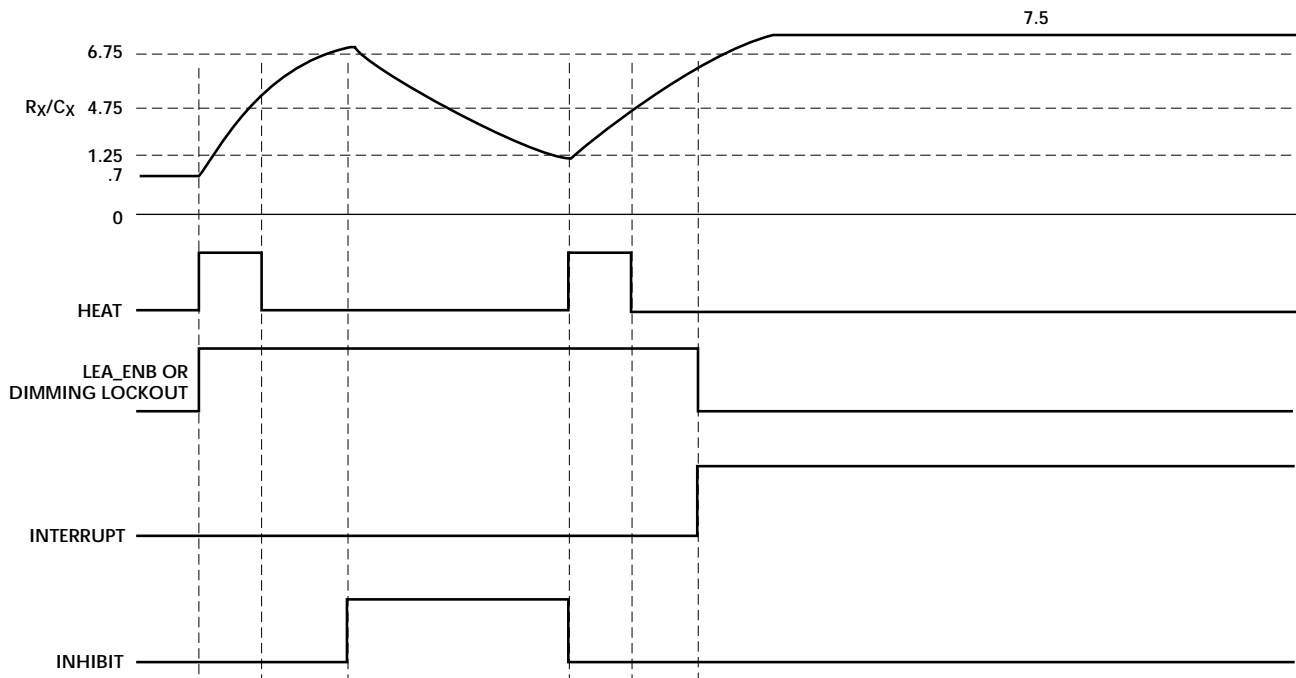

Figure10. Lamp Starting and Restart Timing

## TYPICAL APPLICATIONS

The ML4836 can be used for a variety of lamp types:

- T4 or compact fluorescent lamps
- IEC T8 (linear lamps)
- T5 linear lamps
- T12 linear lamps

The ML4836 can also be used for dimming applications. For example, 20:1 dimming can be achieved using the ML4836 with external dimming units. The applications schematics shown in Figures 11 and 12 are examples of the various uses of the ML4836.

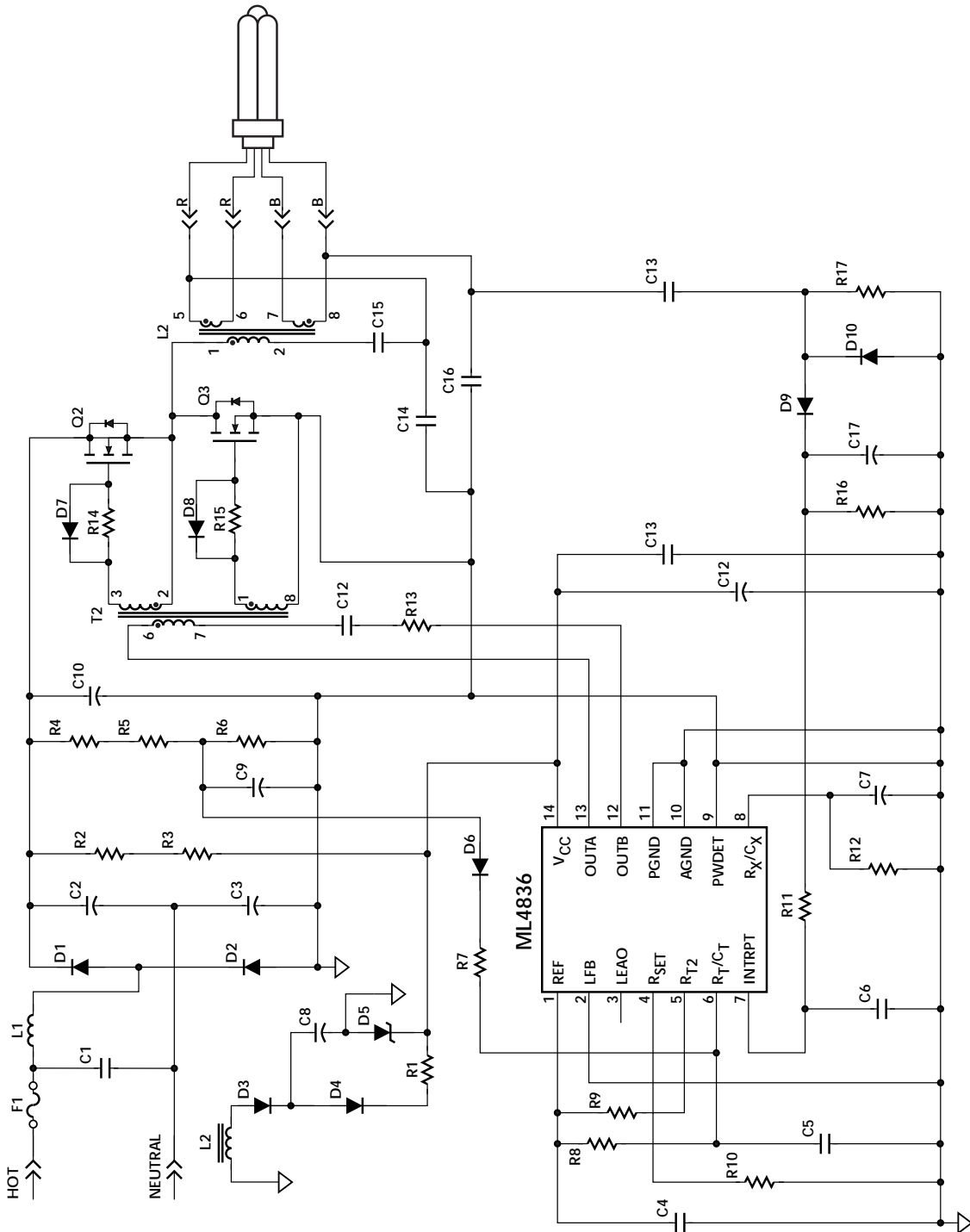
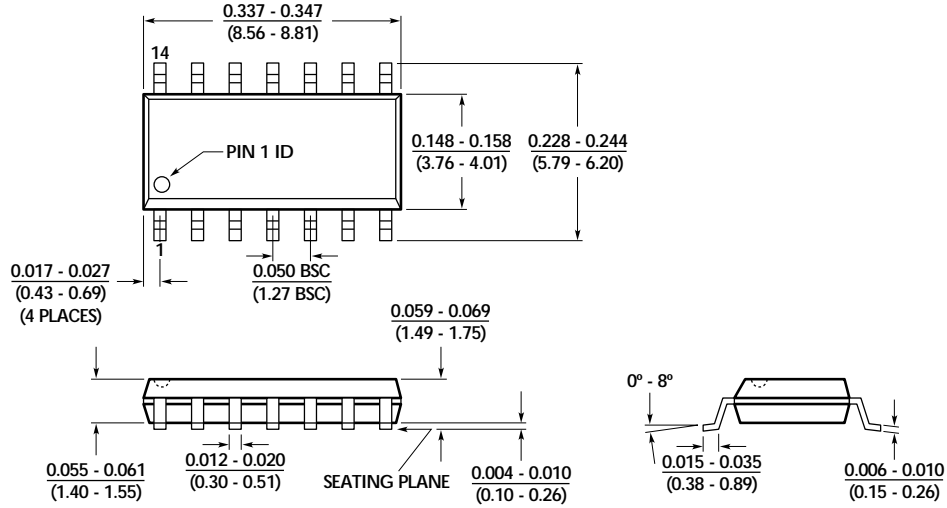

Figure 11. 120V CFL Ballast



## PHYSICAL DIMENSIONS inches (millimeters)

Package: S14  
14-Pin SOIC



Package: P14  
14-Pin PDIP

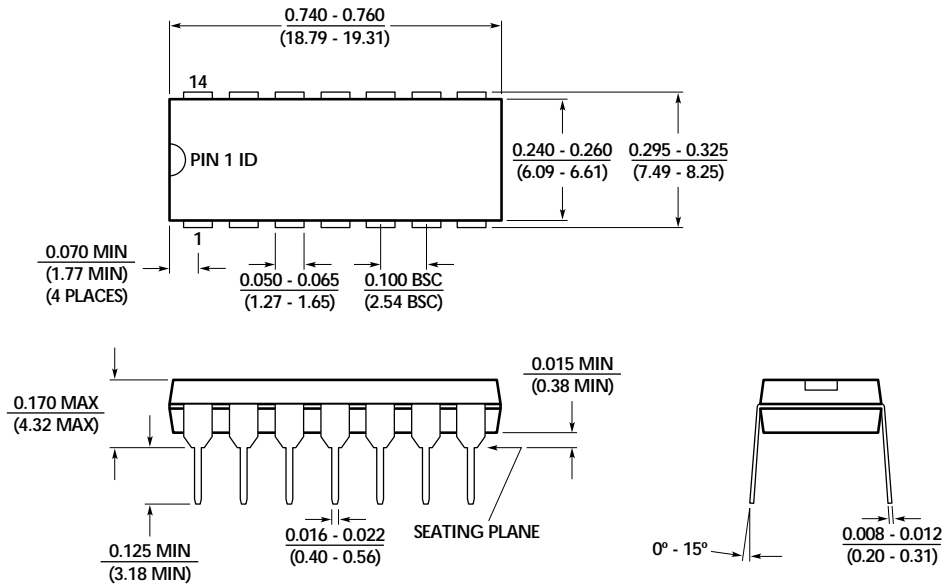

---

**ORDERING INFORMATION**

PART NUMBER	TEMPERATURE RANGE	PACKAGE
ML4836CP (End Of Life)	0°C to 70°C	14-Pin DIP (P14)
ML4836CS (End Of Life)	0°C to 70°C	14-Pin SOIC (S14)

**DISCLAIMER**

FAIRCHILD SEMICONDUCTOR RESERVES THE RIGHT TO MAKE CHANGES WITHOUT FURTHER NOTICE TO ANY PRODUCTS HEREIN TO IMPROVE RELIABILITY, FUNCTION OR DESIGN. FAIRCHILD DOES NOT ASSUME ANY LIABILITY ARISING OUT OF THE APPLICATION OR USE OF ANY PRODUCT OR CIRCUIT DESCRIBED HEREIN; NEITHER DOES IT CONVEY ANY LICENSE UNDER ITS PATENT RIGHTS, NOR THE RIGHTS OF OTHERS.

**LIFE SUPPORT POLICY**

FAIRCHILD'S PRODUCTS ARE NOT AUTHORIZED FOR USE AS CRITICAL COMPONENTS IN LIFE SUPPORT DEVICES OR SYSTEMS WITHOUT THE EXPRESS WRITTEN APPROVAL OF THE PRESIDENT OF FAIRCHILD SEMICONDUCTOR CORPORATION. As used herein:

1. Life support devices or systems are devices or systems which, (a) are intended for surgical implant into the body, or (b) support or sustain life, and (c) whose failure to perform when properly used in accordance with instructions for use provided in the labeling, can be reasonably expected to result in a significant injury of the user.
2. A critical component in any component of a life support device or system whose failure to perform can be reasonably expected to cause the failure of the life support device or system, or to affect its safety or effectiveness.