

DATA SHEET

TZA3004HL SDH/SONET data and clock recovery unit STM1/4 OC3/12

Product specification
Supersedes data of 1998 Feb 09
File under Integrated Circuits, IC19

2000 Nov 28

SDH/SONET data and clock recovery unit STM1/4 OC3/12

TZA3004HL

FEATURES

- Data and clock recovery up to 622 Mb/s
- Multi-rate configurable (155 and 622 Mb/s)
- Differential data input with 2.5 mV (p-p) typical sensitivity
- Differential Current-Mode Logic (CML) data and clock outputs with 50 Ω driving capability
- Adjustable CML output level
- Loop mode for system testing
- Bit error rate related loss of signal detection
- Few external components needed
- Single supply voltage
- Power dissipation 370 mW (typical value)
- LQFP48 plastic package.

APPLICATIONS

- Data and clock recovery in STM1/OC3 and STM4/OC12 transmission systems.

DESCRIPTION

The TZA3004HL is a data and clock recovery IC intended for use in Synchronous Digital Hierarchy (SDH) and Synchronous Optical Network (SONET) systems. The circuit recovers data and extracts the clock signal from an incoming bitstream up to 622 Mb/s. It can be configured for use in STM1/OC3 and STM4/OC12 systems.

ORDERING INFORMATION

TYPE NUMBER	PACKAGE		
	NAME	DESCRIPTION	VERSION
TZA3004HL	LQFP48	plastic low profile quad flat package; 48 leads; body 7 × 7 × 1.4 mm	SOT313-2

SDH/SONET data and clock recovery unit STM1/4 OC3/12

TZA3004HL

BLOCK DIAGRAM

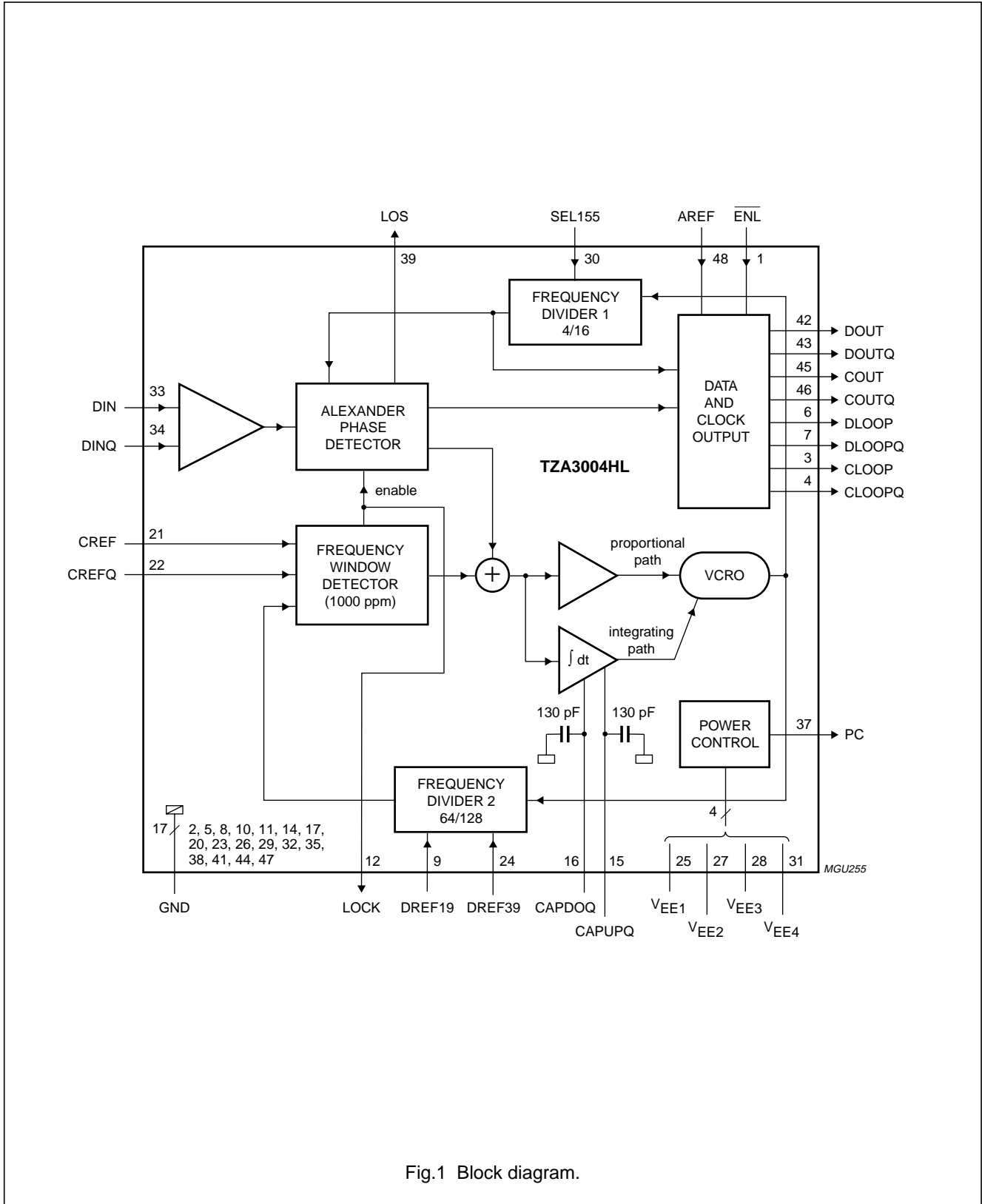

Fig.1 Block diagram.

SDH/SONET data and clock recovery unit

STM1/4 OC3/12

TZA3004HL

PINNING

SYMBOL	PIN	DESCRIPTION
$\overline{\text{ENL}}$	1	loop mode enable input (active LOW)
GND	2	ground; note 1
CLOOP	3	clock output in loop mode (differential)
CLOOPQ	4	inverted clock output in loop mode (differential)
GND	5	ground; note 1
DLOOP	6	data output in loop mode (differential)
DLOOPQ	7	inverted data output in loop mode (differential)
GND	8	ground; note 1
DREF19	9	reference frequency select input 1 (see Table 3)
GND	10	ground; note 1
GND	11	ground; note 1
LOCK	12	phase lock detection output
i.c.	13	internally connected; note 2
GND	14	ground; note 1
CAPUPQ	15	external loop filter capacitor connection
CAPDOQ	16	external loop filter capacitor return connection
GND	17	ground; note 1
i.c.	18	internally connected; note 2
i.c.	19	internally connected; note 2
GND	20	ground; note 1
CREF	21	reference clock input (differential)
CREFQ	22	inverting reference clock input (differential)
GND	23	ground; note 1
DREF39	24	reference frequency select input 2 (see Table 3)
V_{EE1}	25	negative supply voltage (-3.3 V); note 3
GND	26	ground; note 1
V_{EE2}	27	negative supply voltage (-3.3 V); note 3
V_{EE3}	28	negative supply voltage (-3.3 V); note 3
GND	29	ground; note 1
SEL155	30	STM mode select input 3 (see Table 2)
V_{EE4}	31	negative supply voltage (-3.3 V); note 3
GND	32	ground; note 1
DIN	33	data input (differential)
DINQ	34	inverting data input (differential)
GND	35	ground; note 1
i.c.	36	internally connected; note 2
PC	37	control output for negative power supply
GND	38	ground; note 1
LOS	39	loss of signal detection output
i.c.	40	internally connected; note 2

SDH/SONET data and clock recovery unit STM1/4 OC3/12

TZA3004HL

FUNCTIONAL DESCRIPTION

The TZA3004HL recovers data and clock signals from an incoming high speed bitstream. The input signal on pins DIN and DINQ is buffered and amplified by the input circuitry (see Fig.1). The signal is then fed into the Alexander phase detector where the phase of the incoming data signal is compared with that of the internal clock. If the signals are out of phase, the phase detector generates correction pulses (up or down) that shift the phase of the Voltage Controlled Ring Oscillator (VCRO) output in discrete amounts ($\Delta\phi$) until the clock and data signals are in phase. The technique used is based on principles first proposed by J. D. H. Alexander, hence the name of the phase detector.

Data sampling

As shown in Fig.3, the eye pattern of the incoming data is sampled at three instants A, T and B. When clock and data signals are synchronized (locked):

- A is the centre of the data bit
- T is in the vicinity of the next transition
- B is in the centre of the bit following the transition.

If the same level is recorded at both A and B, a transition has not occurred and no action is taken. However, if the levels at A and B are different, a transition has occurred and the phase detector uses the level at T to determine whether the clock was too early or too late with respect to the data transition.

If the levels at A and T are the same but are different from the level at B, the clock was too early and needs to be slowed down a little. The Alexander phase detector then generates a down pulse which stretches a single output pulse from the ring oscillator by approximately 0.25% which is 4 ps of the 1.6 ns bit period in the STM4/OC12 mode. This forces the VCRO to run at a slightly lower frequency for one bit period. The phase of the clock signal is thus shifted fractionally with respect to the data signal.

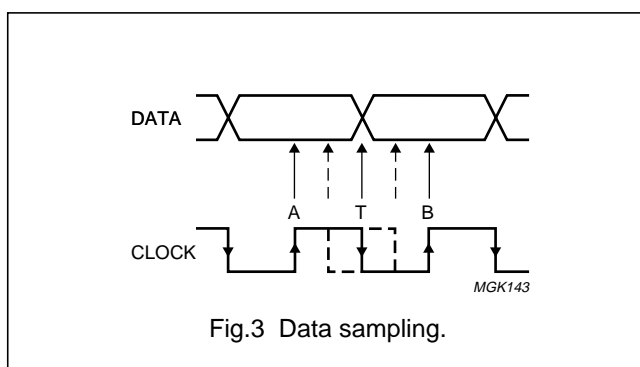

If the levels at B and T are the same but are different from the level at A, the clock was too late and needs to be speeded up for synchronization. The phase detector generates an up pulse forcing the VCRO to run at a slightly higher frequency (+0.25%) for one bit period. The phase of the clock signal is shifted with respect to the data signal (as above, but in the opposite direction). While making these phase adjustments, only the proportional path is active. This type of loop is known as a Bang/Bang Phase-Locked Loop (PLL) as the instantaneous frequency of the VCRO changes in one of two discrete steps ($\pm 0.25\%$).

If the phase and the frequency of the VCRO are incorrect, a long train of up or down pulses is generated. This train of pulses is integrated to generate a control voltage that is used to shift the centre frequency of the VCRO. Once the correct frequency has been established, only the phase will need to be adjusted for synchronization. The proportional path adjusts the phase of the clock signal, whereas the integrating path adjusts the centre frequency.

Frequency window detector

The frequency window detector checks the VCRO frequency which has to be within a 1000 ppm (parts per million) window around the required frequency.

It compares the output of frequency divider 2 with the reference frequency on pins CREF and CREFQ (19.44 or 38.88 MHz; see Table 3). If the VCRO frequency is found to be outside this window, the frequency window detector disables the Alexander phase detector and forces the VCRO output to a frequency within the window. The phase detector then starts acquiring lock again. Due to the loose coupling of 1000 ppm, the reference frequency does not need to be highly accurate or stable. Any crystal based oscillator that generates a reasonably accurate frequency (e.g. 100 ppm) can be used.

Since sampling point A is always in the centre of the eye pattern when the data and clock signals are in phase (locked), the values recorded at this point are taken as the retrieved data. The data and clock signals are available at the CML output buffers, that are capable of driving a 50 Ω load.

RF data and clock input circuit

The schematic of the input circuit is shown in Fig.4.

RF data and clock output circuit

The schematic of the output circuit is shown in Fig.5.

SDH/SONET data and clock recovery unit
STM1/4 OC3/12

TZA3004HL

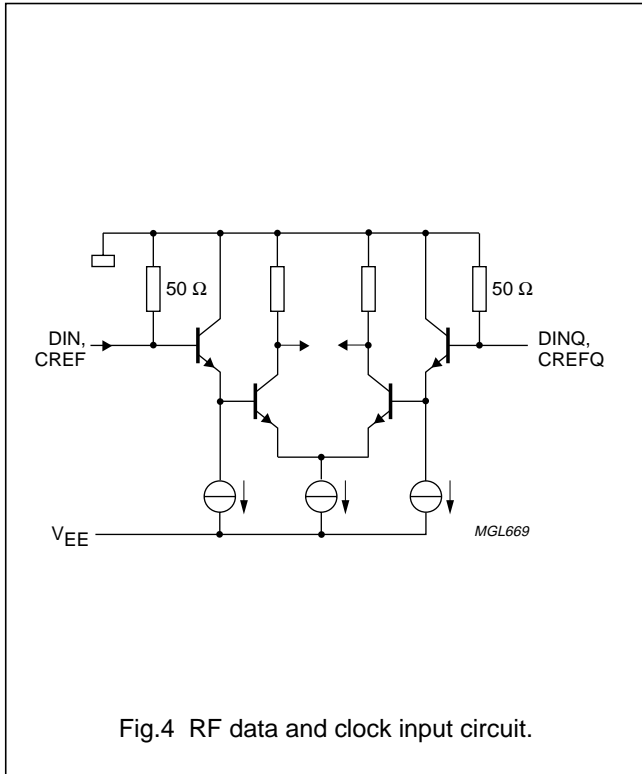

Fig.4 RF data and clock input circuit.

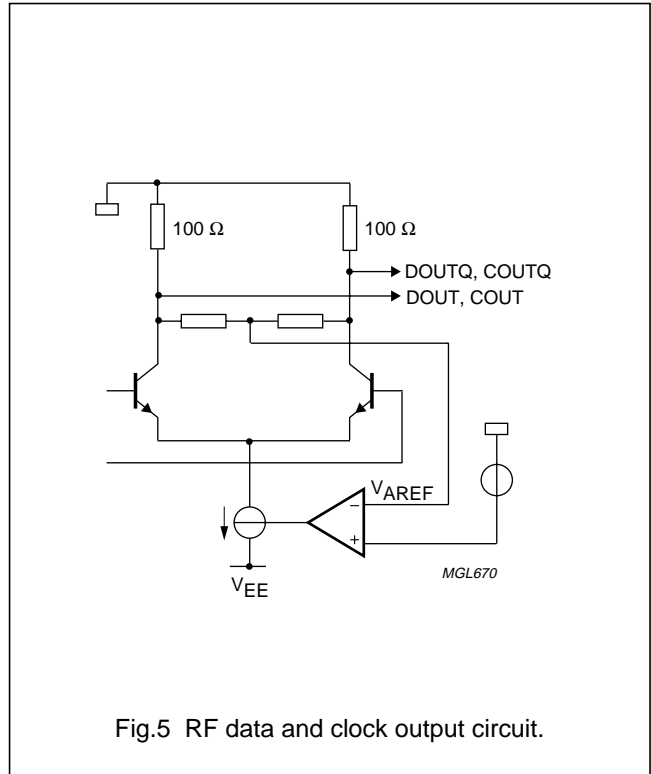

Fig.5 RF data and clock output circuit.

Power supply and power control loop

The TZA3004HL contains an on-board voltage regulator. An external power transistor is needed to deliver the supply to this circuit. The external circuit requirement is straightforward and needs few components. A suitable circuit with a power supply of -4.5 V is illustrated in Fig.6. The inductor shown is an RF choke with an impedance greater than 50 Ω at frequencies higher than 2 MHz. Any transistor with a β of approximately 100 and enough current sink capability can be used.

The TZA3004HL can also be used with a power supply of -5.0 or -5.2 V. The only adaptation to be made to the power control circuit is to change the emitter resistor R1 (see Fig.6 and Table 1).

As long as the power supply rejection ratio is greater than 60 dB for all frequencies, a different power supply configuration could be used.

Table 1 Value of resistor R1.

POWER SUPPLY	RESISTOR R1
-4.5 V	2.0 Ω
-5.0 V	6.8 Ω
-5.2 V	8.2 Ω

Output amplitude reference

The voltage swing at the CML-compatible output stages (pins DOUT, DOUTQ, COUT, COUTQ, DLOOP, DLOOPQ, CLOOP and CLOOPQ) can be controlled by adjusting the voltage on pin AREF (see Fig.7). An internal voltage divider of 500 Ω and 16 kΩ connected between ground and VEE initially fixes this level.

In most applications the outputs will be DC-coupled to a load of 50 Ω. The output level regulation circuit will maintain a 200 mV (p-p) single-ended swing across this load. The voltage on pin AREF is half the single-ended peak-to-peak value of the output signal (-100 mV). No adjustments are necessary with DC-coupling.

When the outputs are AC-coupled, the voltage on pin AREF is half the single-ended peak-to-peak value of

the output signal multiplied by a factor $\frac{R_L + R_o}{R_L}$

where R_L is the external load and R_o is the output impedance of the TZA3004HL (100 Ω).

SDH/SONET data and clock recovery unit
STM1/4 OC3/12

TZA3004HL

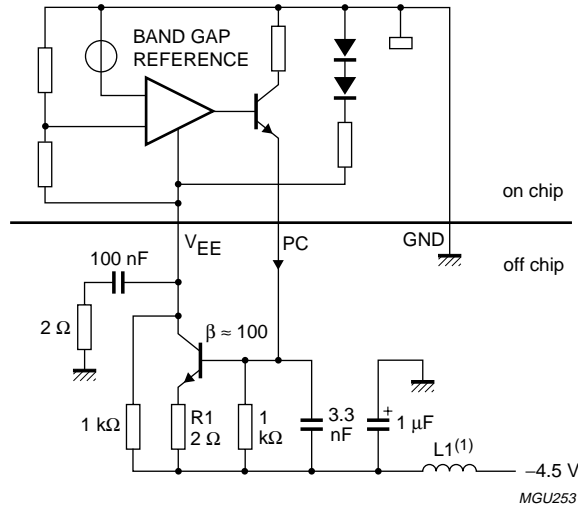

(1) L1 = RF choke type Murata BLM21, 1 μH.

Fig.6 Schematic diagram of TZA3004HL power control loop.

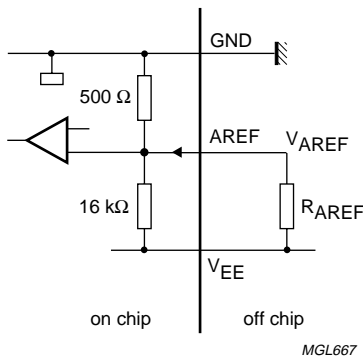

Fig.7 Functionality of pin AREF.

If the outputs are AC-coupled, the formulae for calculating the required voltage on pin AREF and the value of the resistor connected between pins AREF and V_{EE} are:

$$V_{AREF} = -\frac{R_L + R_o}{R_L} \times 0.5V_{swing} \tag{1}$$

and:

$$R_{AREF} = \frac{R1 \times \left(\frac{V_{EE}}{V_{AREF}} - 1\right)}{1 - \left[\frac{R1}{R2} \times \left(\frac{V_{EE}}{V_{AREF}} - 1\right)\right]} \tag{2}$$

where $R1 = 500 \Omega$, $R2 = 16 \text{ k}\Omega$ and $V_{EE} = -3.3 \text{ V}$.

To maintain a single-ended swing of 200 mV (p-p) across a 50 Ω AC-coupled load, the voltage on pin AREF must be

$$-100 \text{ mV} \times \frac{(50 + 100)\Omega}{50 \Omega} = -300 \text{ mV}.$$

This can be achieved by connecting a 7.3 kΩ resistor between pins AREF and V_{EE} .

SDH/SONET data and clock recovery unit STM1/4 OC3/12

TZA3004HL

External capacitor for loop filter

The loop filter is an integrator with a built-in capacitance of 2×130 pF. To ensure loop stability while the frequency window detector is active, an external capacitance of 200 nF should be connected between pins CAPUPQ and CAPDOQ.

Loop mode enable

The loop mode is provided for system testing (see Fig.8).

Loop mode is enabled by applying a voltage lower than 0.8 V (TTL LOW-level) to pin ENL. In loop mode, the outputs on pins DLOOP, DLOOPQ, CLOOP and CLOOPQ are switched on.

A voltage higher than 2.0 V (TTL HIGH-level) applied to pin ENL switches on pins DOUT, DOUTQ, COUT and COUTQ while pins DLOOP, DLOOPQ, CLOOP and CLOOPQ are disabled to minimize power consumption.

Connecting pin ENL to V_{EE} (-3.3 V) enables all outputs.

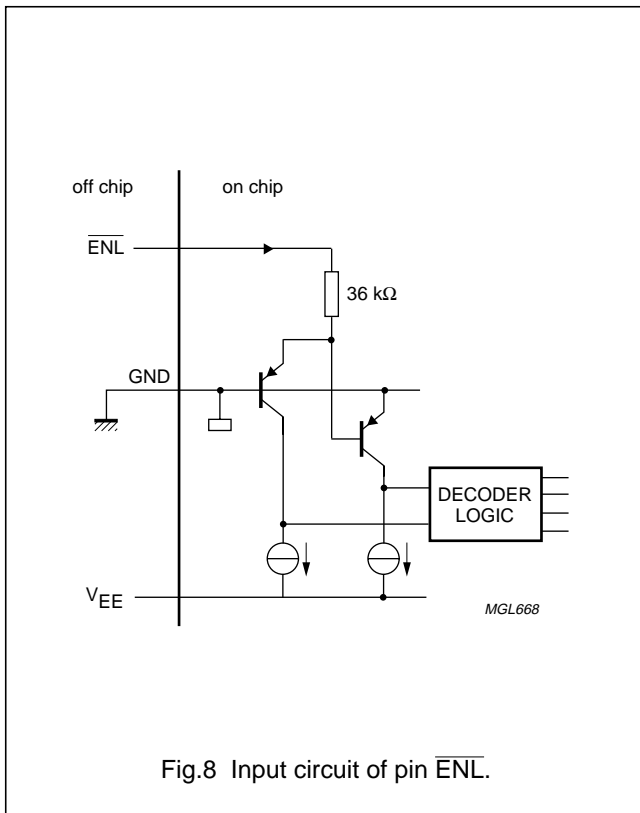

Fig.8 Input circuit of pin ENL.

Lock detection

The LOCK output can be interpreted as an indication that the reference clock is present on pin CREF and that the acquisition aid (frequency window detector) is functioning properly.

LOCK is an open-collector TTL output to be connected via a 10 kΩ pull-up resistor to a positive supply voltage. If the VCO frequency is within a 1000 ppm window around the desired frequency, pin LOCK will stay at HIGH-level. If no reference clock is present, or the VCO is outside the 1000 ppm window, pin LOCK will be at a LOW-level. The logic level on pin LOCK does not indicate locking of the PLL to the incoming data; this is done by the signal on pin LOS.

Loss of signal detection

The Loss Of Signal (LOS) function is closely related to the functionality of the Alexander phase detector (see Fig.3 for the meaning of A, B and T in this section).

The phase detector takes no action if there has been no transition and the values at sample points A and B are the same. However, if levels A and B are equal but level at T is different, even with no transition, the incorrect level at T could lead to a bit error. This incorrect level could be due to noise or from poor signal integrity. The cumulative affect of bit errors could cause the PLL to lose lock and the LOS alarm to be asserted. The LOS alarm assert level is approximately Bit Error Rate (BER) = 5×10^{-2} and the de-assert level is approximately BER = 1×10^{-3} .

LOS detection functions correctly if the input signal is larger than the input offset of the TZA3004HL. If the input signal is smaller, it is masked by the input offset and interpreted as consecutive bits of the same sign, thus obstructing LOS detection. In practice, an optical front-end device with a noise level larger than the specified offset of the TZA3004HL will ensure proper LOS indication.

The LOS detection is BER related, but not dependent on the data stream content or protocol. Therefore, an SDH/SONET data stream is no prerequisite for a proper LOS function. Since the LOS function of the TZA3004HL is derived from digital signals, it is a good supplement to an analog, amplitude based, LOS indication.

Pin LOS is an open-collector TTL compatible output. that needs a pull-up resistor connected to a positive supply voltage to function.

The LOS pin will be at a (TTL) HIGH-level if the data signal is absent on pins DIN and DINQ or if BER > 5×10^{-2} ; otherwise pin LOS will be at LOW-level if BER < 1×10^{-3} .

**SDH/SONET data and clock recovery unit
STM1/4 OC3/12**

TZA3004HL

STM mode selection

The VCRO has a very wide tuning range. However, the performance of the TZA3004HL is optimized for SDH/SONET bit rates.

Due to the nature of the PLL, the very wide tuning range is a necessity for proper lock behaviour over the guaranteed temperature range, aging and batch-to-batch spread.

Though it may seem that the TZA3004HL is capable of recovering bit rates other than SDH/SONET (STM1/OC3 and STM4/OC12), lock behaviour cannot be guaranteed.

The required SDH/SONET bit rate is selected by connecting pin SEL155 to the ground plane or to the supply voltage V_{EE} (see Table 2):

- For STM4/OC12 (622.08 Mbits/s) operation, pin SEL155 is to be connected to ground (pin GND)
- For STM1/OC3 (155,52 Mbits/s) operation, pin SEL155 is to be connected to V_{EE} .

The connection to V_{EE} or ground carries a current of a few milliamperes and should have low resistance and inductance; short printed-circuit board tracks are recommended. In some cases it may be necessary to add a decoupling capacitor near the selection pin to provide a clean return path for RF signals.

When the TZA3004HL is used in an application with a fixed data rate it is best to connect pin SEL155 by a short copper trace or a via to the ground plane or supply voltage V_{EE} . If a selectable reference clock frequency is required in the application, the pin can be controlled through a low-ohmic switching FET, e.g. BSH103 or equivalent (low R_{DSon}).

Table 2 STM mode select

MODE	BIT RATE (Mbits/s)	DIVISION FACTOR	LEVEL ON PIN SEL155
STM1/OC3	155.52	16	V_{EE}
STM4/OC12	622.08	4	ground

Reference frequency select

A reference clock signal of 19.44 or 38.88 MHz must be connected to pins CREF and CREFQ. Pins DREF19 and DREF39 are used to select the appropriate output frequency at frequency divider 2 (see Table 3).

To minimize the adverse influence of reference clock crosstalk, a differential signal with an amplitude from 75 to 150 mV (p-p) is advised.

Since the reference clock is only used as an acquisition aid for the PLL of the frequency window detector, the quality of the reference clock (i.e. phase noise) is not important. There is no phase noise specification imposed on the reference clock generator and even frequency stability may be in the order of 100 ppm. In general, most inexpensive crystal-based oscillators are suitable.

There are two application possibilities for the TZA3004HL reference clock:

- A fixed reference clock frequency, here it is best to connect pins DREF19 and DREF39 using a short track or a via to the ground plane or the supply voltage V_{EE}
- A selectable reference clock frequency in which the pins can be controlled through low-ohmic switching FETs, e.g. BSH103 or equivalent (low R_{DSon}).

Table 3 Reference frequency selection

FREQUENCY (MHz)	DIVISION FACTOR	LEVEL ON PIN	
		DREF19	DREF39
38.88	64	ground	V_{EE}
19.44	128	V_{EE}	V_{EE}

SDH/SONET data and clock recovery unit STM1/4 OC3/12

TZA3004HL

Application with positive supply voltage

The versatile design of the TZA3004HL allows the device to operate in a positive supply voltage application, although some pins then have a different operating mode. This section deals with these differences and supports the user with achieving a successful application of the TZA3004HL in a +5 V environment.

APPLICATION DIAGRAM

A sample application diagram is shown in Fig.22. It should be noted that all GND pins are now connected to V_{CC} and all V_{EE} pins are still connected to the regulated voltage from the power controller.

OUTPUT SELECTION

In a positive supply voltage application, the loop mode is the default RF output. Due to the decoding logic on pin ENL, it is only possible to select the loop mode outputs or enable all the outputs.

If pin \overline{ENL} is connected to V_{CC} (+5 V), only the loop mode outputs are active (see Table 4). When pin \overline{ENL} is connected to V_{EE} (the voltage is approximately 3.3 V below V_{CC}), all outputs become active. In the positive supply voltage application, the normal mode outputs cannot be selected, unless the voltage on pin \overline{ENL} is 2 V above the positive supply voltage (V_{CC}).

CAUTION

Do not to connect pin \overline{ENL} to ground, because this will destroy the IC.

LOSS OF SIGNAL AND LOCK DETECTION

In the negative supply application, pins LOS and LOCK are open-collector outputs that require pull-up resistors to a positive supply voltage.

In the positive supply application, the pull-up voltage would need to be higher than the positive supply voltage. The signals on pins LOS and LOCK would no longer be TTL compatible. However, the internal circuit on pins LOS and LOCK can be used in a current mirror configuration (see Fig.9). This requires only an external PNP transistor (e.g. BC857 or equivalent) to mirror the current. A 10 k Ω pull-down resistor from the collector of the external transistor to ground yields a TTL compatible signal again but it is inverted. The meaning of the LOS and LOCK flag when used in the positive supply application is shown in Table 5.

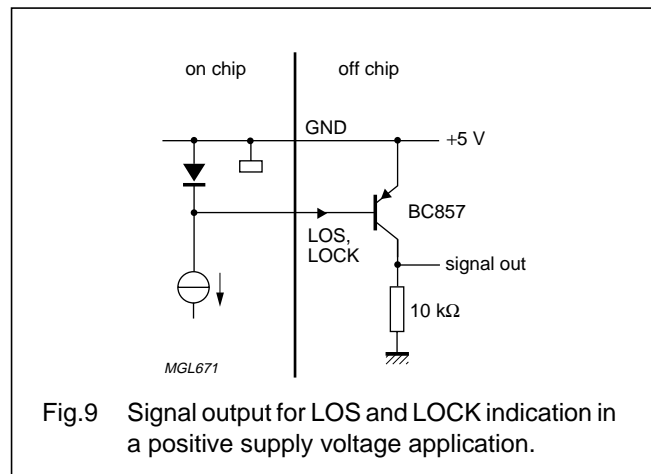

Fig.9 Signal output for LOS and LOCK indication in a positive supply voltage application.

Table 4 Output selection in a positive supply voltage application

MODE	LEVEL ON PIN \overline{ENL}	OUTPUT	
		DLOOP, DLOOPQ, CLOOP AND CLOOPQ	DOUT, DOUTQ, COUT AND COUTQ
Loop	V_{CC} (+5 V)	active	–
Loop and normal	V_{EE} ($V_{CC} - 3.3$ V)	active	active
Normal	$V_{CC} + 2$ V	–	active

Table 5 LOS and LOCK indication in a positive supply voltage application

SIGNAL	DESCRIPTION	LEVEL	TTL
LOS active	loss of signal: BER > 5×10^{-2}	0 V (ground)	LOW
LOS inactive	no loss of signal: BER < 1×10^{-3}	+5 V (V_{CC})	HIGH
LOCK active	reference clock present and VCRO inside 1000 ppm window	0 V (ground)	LOW
LOCK inactive	no reference clock present or VCRO outside 1000 ppm window	+5 V (V_{CC})	HIGH

SDH/SONET data and clock recovery unit STM1/4 OC3/12

TZA3004HL

DIVIDER SETTINGS

The reference frequency dividers and the STM mode selectors operate in a similar manner in a positive supply voltage application. The only difference is that pins formerly connected to ground should now be connected to V_{CC} (+5 V). Pins connected to V_{EE} should continue to be connected to V_{EE} , as connecting these pins to ground (0 V) will damage the IC.

RF INPUT AND OUTPUTS

All RF inputs, outputs and internal signals of the TZA3004HL are referenced to pins GND. In the positive supply voltage application, this means that all RF signals are referenced to V_{CC} . Therefore a clean V_{CC} rail is of ultimate importance for proper RF performance. The best performance is obtained when the transmission line reference plane is also decoupled to V_{CC} . Careful design of V_{CC} and good decoupling schemes should be taken into account. While designing the printed-circuit board, keep in mind that the V_{CC} has become what was formerly ground.

While laying out the application, the return path is the most important issue to be considered. Always examine carefully the current-carrying loops in the design. Care should be taken that low-ohmic and low-inductance return paths are available for all frequencies (both of interest and not of interest). These return paths should preferably have an enclosed area as small as possible, both horizontally and vertically (by means of through-holes or vias). The position of a decoupling capacitor is very important. A decoupling capacitor in an unfavourable position could do more damage than would completely omitting the capacitor. In the correct location it could be the difference between mediocre results and the ultimate achievement.

SDH/SONET data and clock recovery unit STM1/4 OC3/12

TZA3004HL

LIMITING VALUES

In accordance with the Absolute Maximum Rating System (IEC 60134).

SYMBOL	PARAMETER	MIN.	MAX.	UNIT
V_{EE}	negative supply voltage	-6	+0.5	V
V_n	DC voltage on pins CLOOP, CLOOPQ, DLOOP, DLOOPQ, CREF, CREFQ, DIN, DINQ, DOUT, DOUTQ, COUT and COUTQ \overline{ENL} , LOCK and LOS, DREF19, DREF39, SEL155, PC and AREF CAPUPQ and CAPDOQ	-1 $V_{EE} - 0.5$ $V_{EE} - 0.5$ $V_{EE} + 0.5$	+0.5 +5.5 +0.5 -0.5	V V V V
I_n	input current on pins \overline{ENL} CREF, CREFQ, DIN and DINQ	- -20	1 +10	mA mA
P_{tot}	total power dissipation	-	700	mW
T_{amb}	ambient temperature	-40	+85	°C
T_j	junction temperature	-	+110	°C
T_{stg}	storage temperature	-65	+150	°C

HANDLING INSTRUCTIONS

Precautions should be taken to avoid damage through electrostatic discharge.

THERMAL CHARACTERISTICS

SYMBOL	PARAMETER	CONDITIONS	VALUE	UNIT
$R_{th(j-s)}$	thermal resistance from junction to solder point		46	K/W
$R_{th(j-a)}$	thermal resistance from junction to ambient	in free air; note 1	67	K/W

Note

1. Thermal resistance from junction to ambient is determined with the IC soldered on a standard single sided $57 \times 57 \times 1.6$ mm FR4 epoxy PCB with 35 μ m thick copper traces. The measurements are performed in still air.

SDH/SONET data and clock recovery unit

STM1/4 OC3/12

TZA3004HL

CHARACTERISTICS

$V_{EE} = -3.3$ V; $T_{amb} = -40$ to $+85$ °C; typical values measured at $T_{amb} = 25$ °C; all voltages are measured with respect to GND; unless otherwise specified.

SYMBOL	PARAMETER	CONDITIONS	MIN.	TYP.	MAX.	UNIT
Supplies						
V_{EE}	negative supply voltage	see Fig.12; note 1	-3.50	-3.30	-3.10	V
I_{EE}	negative supply current	open outputs; see Fig.13	-	112	155	mA
P_{tot}	total power dissipation		-	370	550	mW
Data and clock inputs: pins DIN, DINQ, CREF and CREFQ						
$V_{i(p-p)}$	input voltage (peak-to-peak value)	50 Ω measurement system; see Fig.10; notes 2 and 3	7	200	450	mV
$V_{i(sens)(p-p)}$	input sensitivity (peak-to-peak value)	50 Ω measurement system; notes 2 and 4	-	2.5	7	mV
V_{IO}	DC input offset voltage	50 Ω measurement system	-3	0	+3	mV
V_I	input voltage	50 Ω measurement system	-600	-200	+250	mV
Z_i	input impedance	single-ended; see Fig.4; note 5	-	50	-	Ω
Data and clock outputs: pins DOUT, DOUTQ, DLOOP, DLOOPQ, COUT, COUTQ, CLOOP and CLOOPQ						
$V_{o(p-p)}$	output voltage swing (peak-to-peak value)	50 Ω measurement system; single-ended; see Fig.10 default adjustment; note 6 special adjustment; note 7	170 50	200 -	210 400	mV mV
V_O	output voltage		-600	-	0	mV
Z_o	output impedance	single-ended	-	100	-	Ω
$t_{r(C)}$	clock output rise time	differential; 20% to 80%	-	90	-	ps
$t_{f(C)}$	clock output fall time	differential; 20% to 80%	-	90	-	ps
$t_{r(D)}$	data output rise time	differential; 20% to 80%	-	200	-	ps
$t_{f(D)}$	data output fall time	differential; 20% to 80%	-	200	-	ps
$t_{d(D-C)}$	data-to-clock delay	see Fig.11; note 8	250	280	310	ps
Output amplitude adjustment: pin AREF						
V_{AREF}	output amplitude reference voltage	floating pin	-110	-100	-90	mV
Power control output: pin PC						
g_m	transconductance		-84	-60	-42	mA/V
I_o	output current		1	-	3.5	mA
Loop mode enable input: pin ENL						
V_{IL}	LOW-level input voltage		-	-	0.8	V
V_{IH}	HIGH-level input voltage		2.0	-	-	V
Phase lock indicator: pin LOCK						
V_{OL}	LOW-level output voltage	note 9	-0.6	-	-	V
V_{OH}	HIGH-level output voltage	note 9	-	-	3.3	V

SDH/SONET data and clock recovery unit

STM1/4 OC3/12

TZA3004HL

SYMBOL	PARAMETER	CONDITIONS	MIN.	TYP.	MAX.	UNIT	
Loss of signal indicator: pin LOS							
V _{OL}	LOW-level output voltage	note 9	-0.6	-	-	V	
V _{OH}	HIGH-level output voltage	note 9	-	-	3.3	V	
t _{as}	assert time	note 10	-	0.1	-	μs	
t _{das}	de-assert time	note 10	-	10	-	μs	
BER _{as}	assert bit error rate	note 10	-	5 × 10 ⁻²	-	BER	
BER _{das}	de-assert bit error rate	note 10	-	1 × 10 ⁻³	-	BER	
PLL characteristics							
t _{acq}	acquisition time	CREF = 19.44 MHz	-	100	200	μs	
		CREF = 38.88 MHz	-	50	200	μs	
J _{tol(p-p)}	jitter tolerance (peak-to-peak value)	STM1/OC3 mode; note 11					
		f = 6.5 kHz	1.5	>10	-	UI	
		f = 65 kHz	0.15	1.3	-	UI	
		f = 1 MHz	0.15	0.8	-	UI	
		STM4/OC12 mode; note 11					
		f = 25 kHz	1.5	>10	-	UI	
f = 250 kHz	0.15	1.3	-	UI			
f = 5 MHz	0.15	0.35	-	UI			
J _{gen(p-p)}	jitter generation (peak-to-peak value)	STM1/OC3 mode; note 12					
		f = 500 Hz to 1.3 MHz	-	0.039	0.50	UI	
		f = 12 kHz to 1.3 MHz	-	0.032	0.10	UI	
		f = 65 kHz to 1.3 MHz	-	0.032	0.10	UI	
		STM4/OC12 mode; note 12					
		f = 1 kHz to 5 MHz	-	0.050	0.50	UI	
f = 12 kHz to 5 MHz	-	0.040	0.10	UI			
f = 250 kHz to 5 MHz	-	0.052	0.10	UI			
J _{gen(rms)}	jitter generation (RMS value)	STM1/OC3 mode; note 12					
		f = 500 Hz to 1.3 MHz	-	0.0060	-	UI	
		f = 12 kHz to 1.3 MHz	-	0.0046	-	UI	
		f = 65 kHz to 1.3 MHz	-	0.0041	-	UI	
		STM4/OC12 mode; note 12					
		f = 1 kHz to 5 MHz	-	0.0093	-	UI	
f = 12 kHz to 5 MHz	-	0.0079	-	UI			
f = 250 kHz to 5 MHz	-	0.0081	-	UI			
TDR	transitionless data run	note 13	-	2000	-	bits	

**SDH/SONET data and clock recovery unit
STM1/4 OC3/12**

TZA3004HL**Notes to the characteristics**

1. Typical power supply voltage for the voltage regulator is -4.5 V (see Fig.6).
2. It is assumed that both CML inputs carry a complementary signal with the specified peak-to-peak value (true differential excitation).
3. The specified input voltage range is the guaranteed and tested range for proper operation; $\text{BER} < 1 \times 10^{-10}$.
4. An input sensitivity of 7 mV (p-p) for $\text{BER} < 1 \cdot 10^{-10}$ is guaranteed. The typical input sensitivity for $\text{BER} < 1 \times 10^{-10}$ is 2.5 mV (p-p).
5. CML inputs are terminated internally using on-chip resistors of $50\ \Omega$ connected to ground.
6. Output voltage range with default reference voltage on pin AREF (floating).
7. Output voltage range with adjustment of voltage on pin AREF (see Section "Output amplitude reference").
8. Measured with 1010 data pattern, single-ended output signals and rising edges of the signals on pins COUT to DOUT or pins CLOOP to DLOOP. It should be noted that small deviations of the specified value are possible if measured differentially.
9. External pull-up resistor of $10\text{ k}\Omega$ connected to supply voltage of $+3.3\text{ V}$.
10. LOS assert or de-assert timing and BER level are for indication only. The values are neither production tested nor guaranteed.
11. Measured in accordance with ITU specification G.958. Measured on demoboard OM5802 for STM1/OC3 and STM4/OC12. For more information, see "*Application note AN97065*".
12. Measured in accordance with ITU specification G.813 and 1 dB above the system input sensitivity power level. Measured on demoboard OM5802 for STM1/OC3 and STM4/OC12.
13. TDR is bit rate independent.

SDH/SONET data and clock recovery unit
STM1/4 OC3/12

TZA3004HL

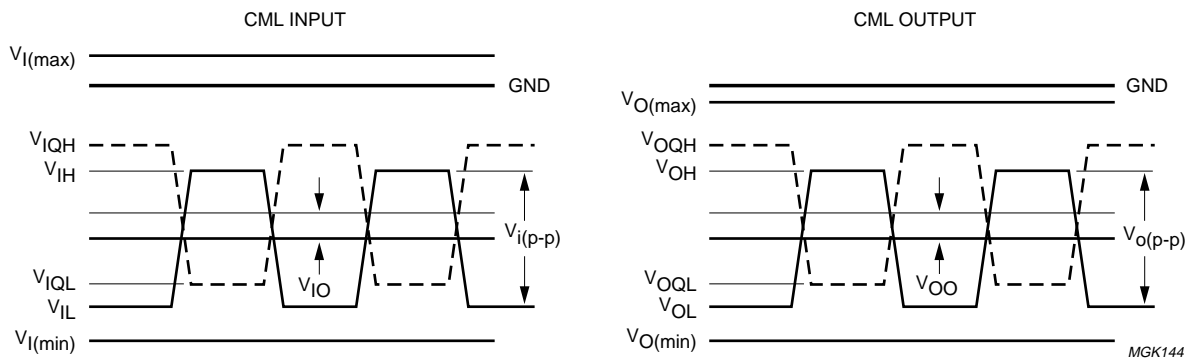

Fig.10 Logic level symbol definitions for CML.

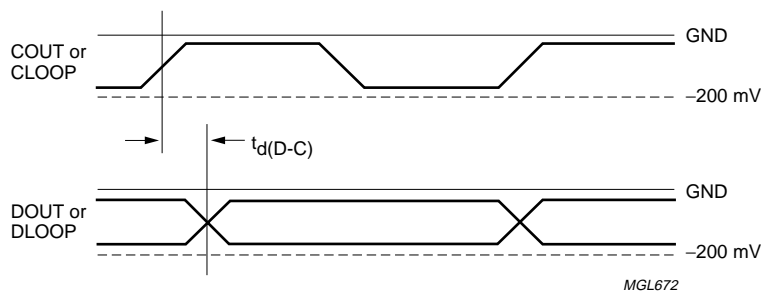
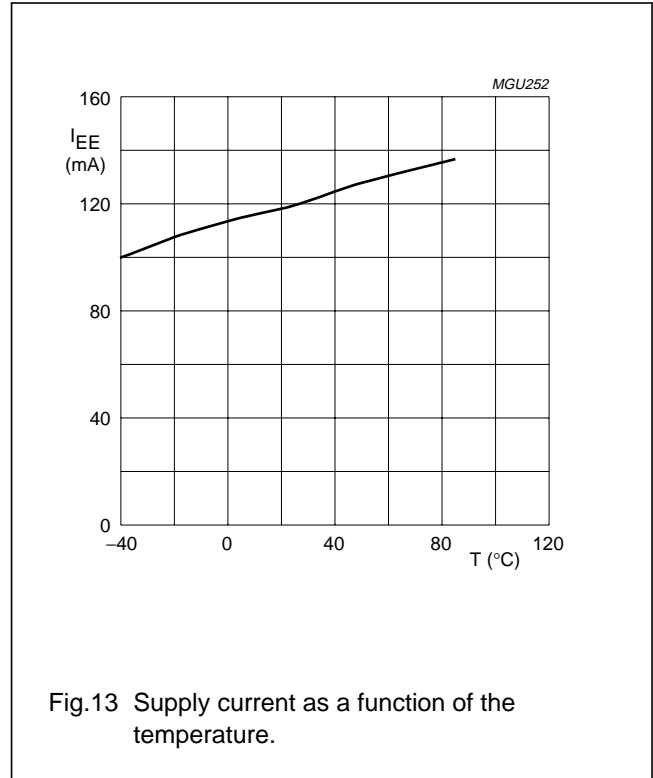
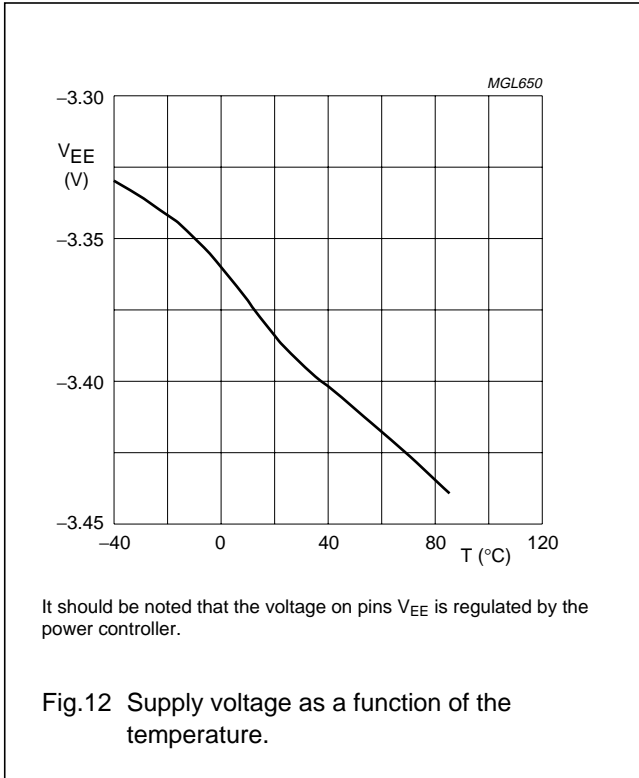

Fig.11 Data-to-clock delay for CML outputs: COUT to DOUT or CLOOP to DLOOP.

SDH/SONET data and clock recovery unit
STM1/4 OC3/12

TZA3004HL

TYPICAL PERFORMANCE CHARACTERISTICS



SDH/SONET data and clock recovery unit
STM1/4 OC3/12

TZA3004HL

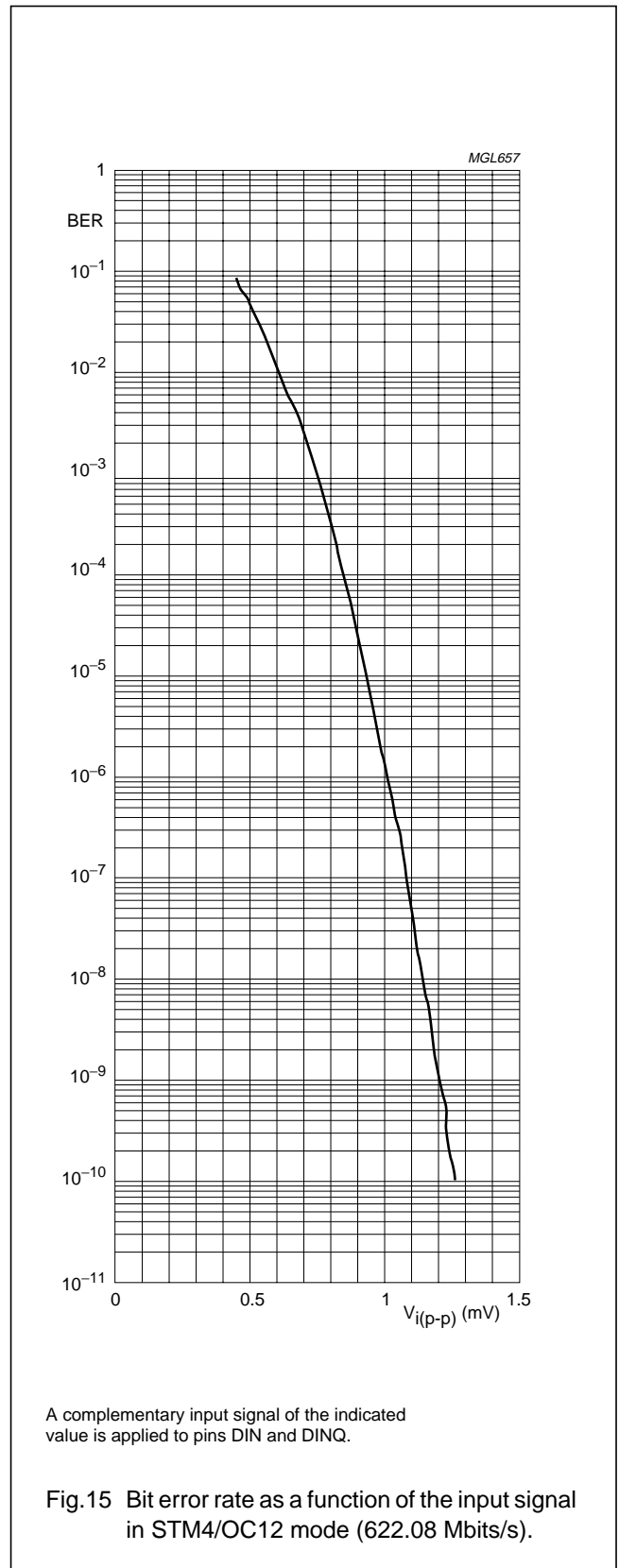
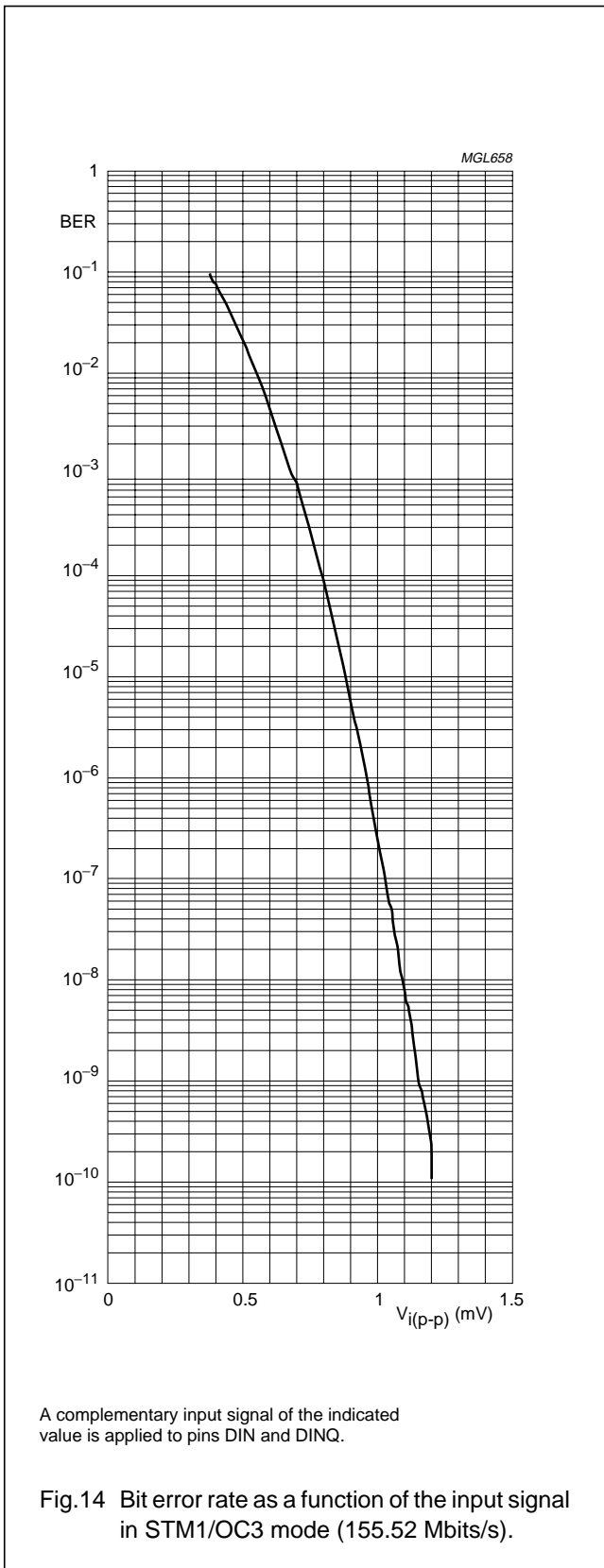

SDH/SONET data and clock recovery unit
STM1/4 OC3/12

TZA3004HL

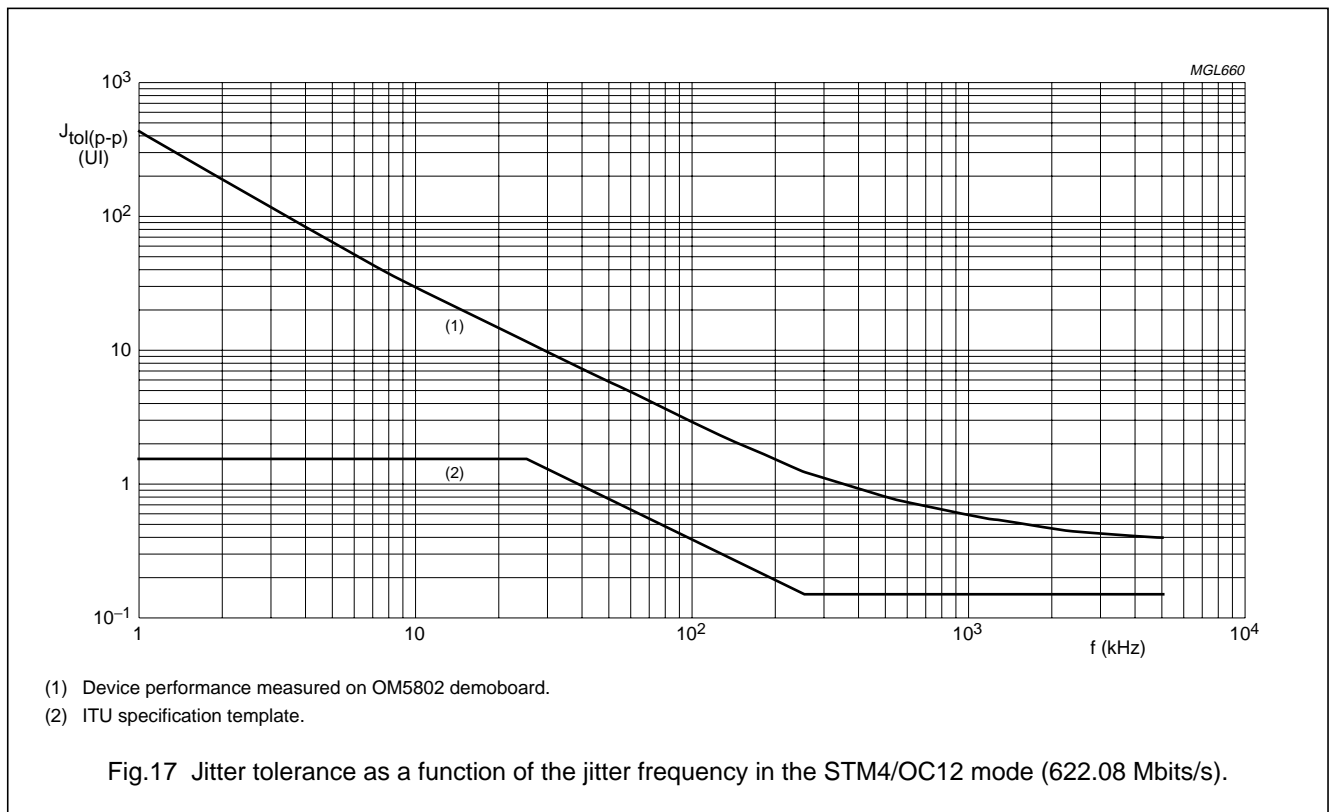
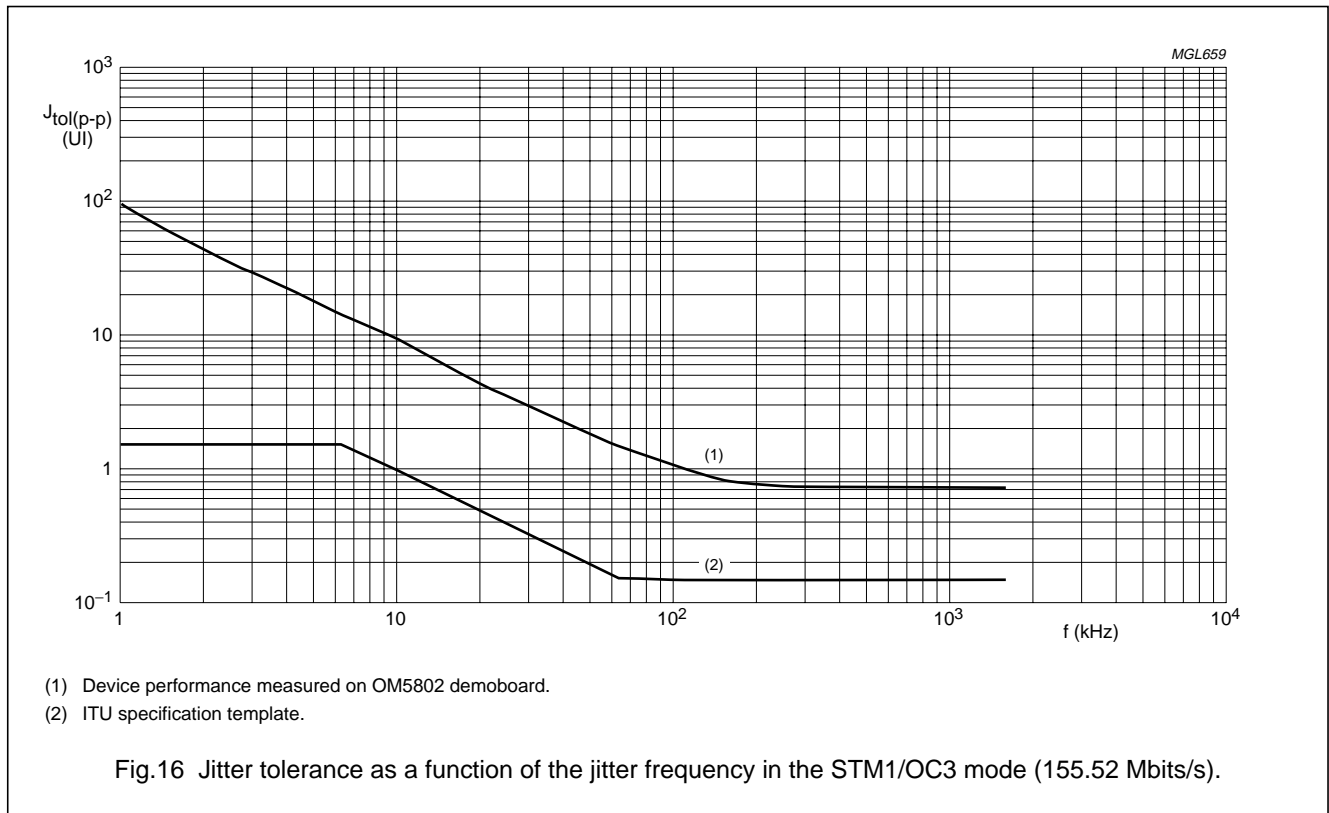

SDH/SONET data and clock recovery unit
STM1/4 OC3/12

TZA3004HL

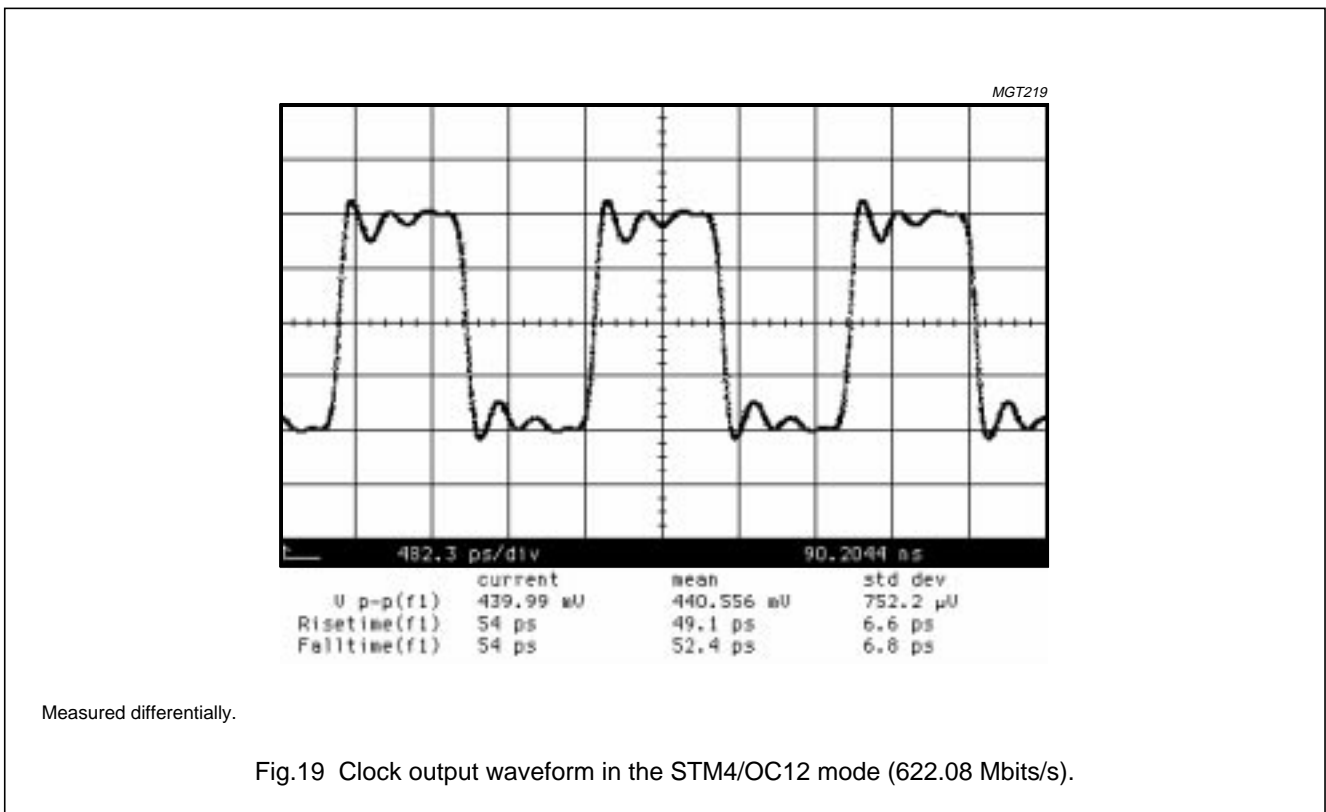
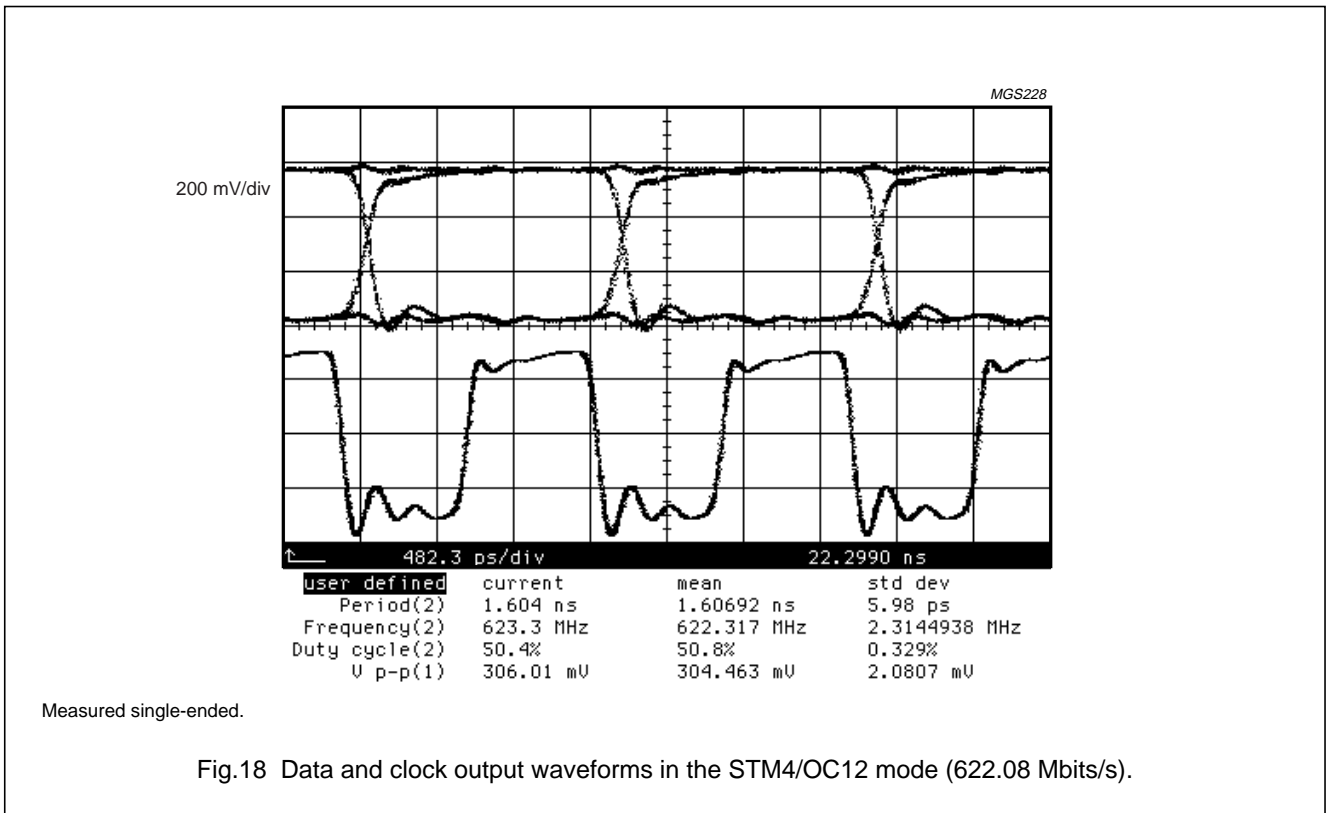

SDH/SONET data and clock recovery unit
STM1/4 OC3/12

TZA3004HL

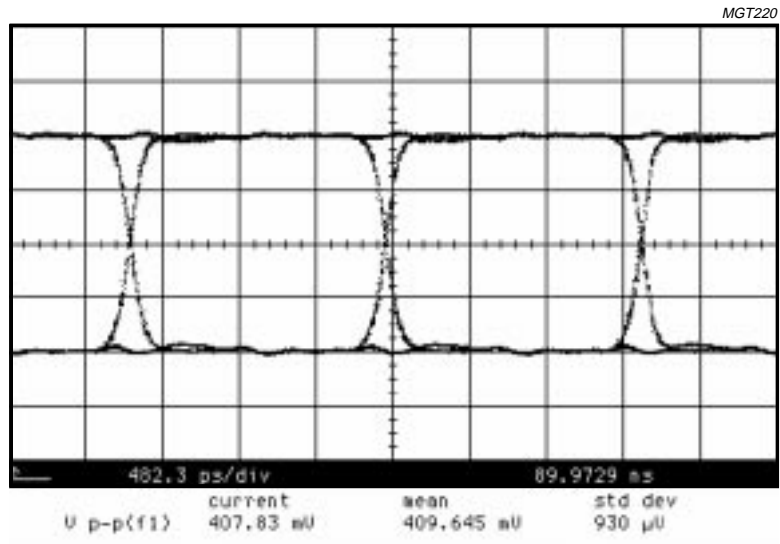

Measured differentially; PRBS $2^{23} - 1$ pattern.

Fig.20 Data output waveform in the STM4/OC12 mode (622.08 Mbits/s).

SDH/SONET data and clock recovery unit
STM1/4 OC3/12

TZA3004HL

APPLICATION INFORMATION

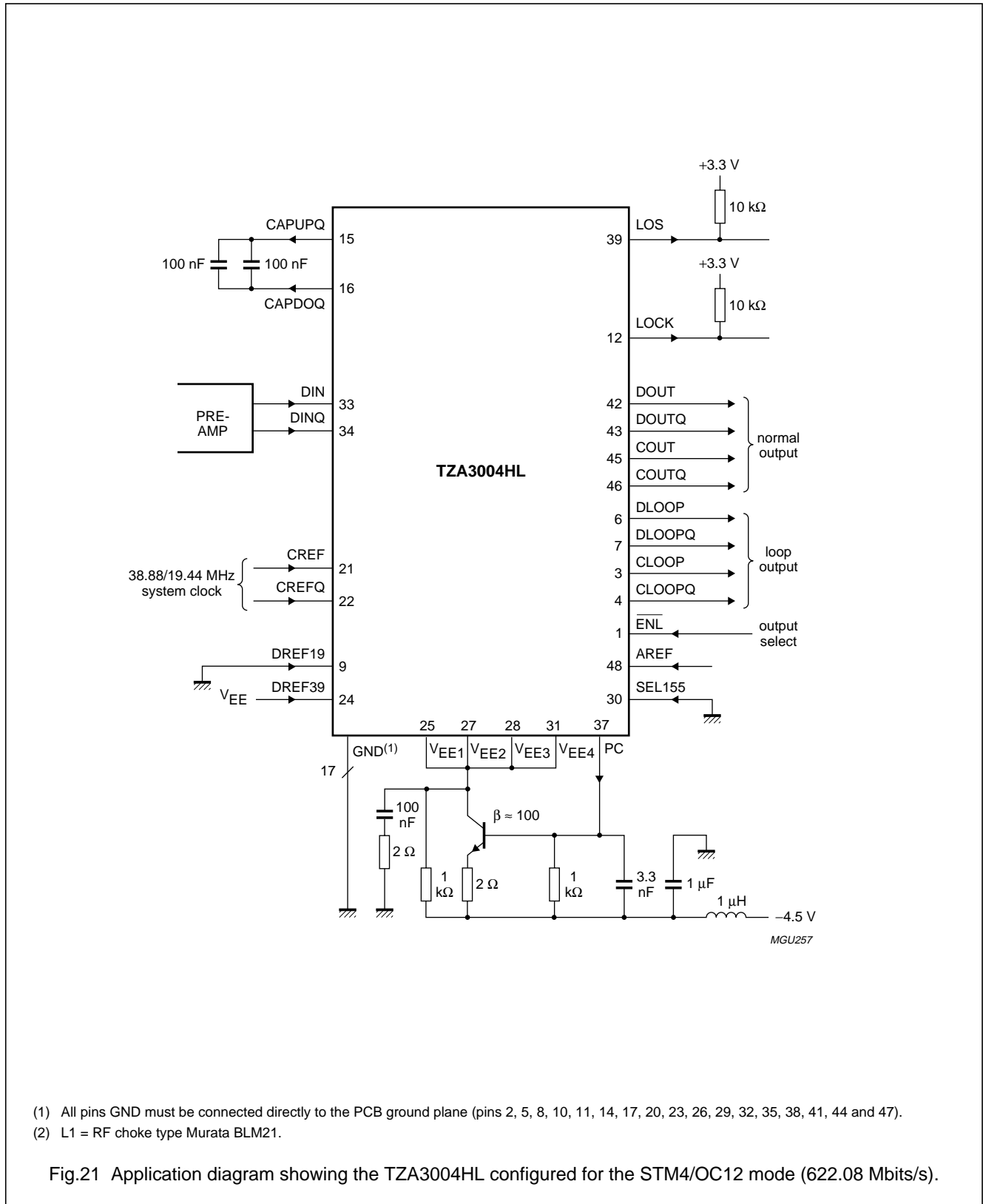

- (1) All pins GND must be connected directly to the PCB ground plane (pins 2, 5, 8, 10, 11, 14, 17, 20, 23, 26, 29, 32, 35, 38, 41, 44 and 47).
- (2) L1 = RF choke type Murata BLM21.

Fig.21 Application diagram showing the TZA3004HL configured for the STM4/OC12 mode (622.08 Mbits/s).

SDH/SONET data and clock recovery unit
STM1/4 OC3/12

TZA3004HL

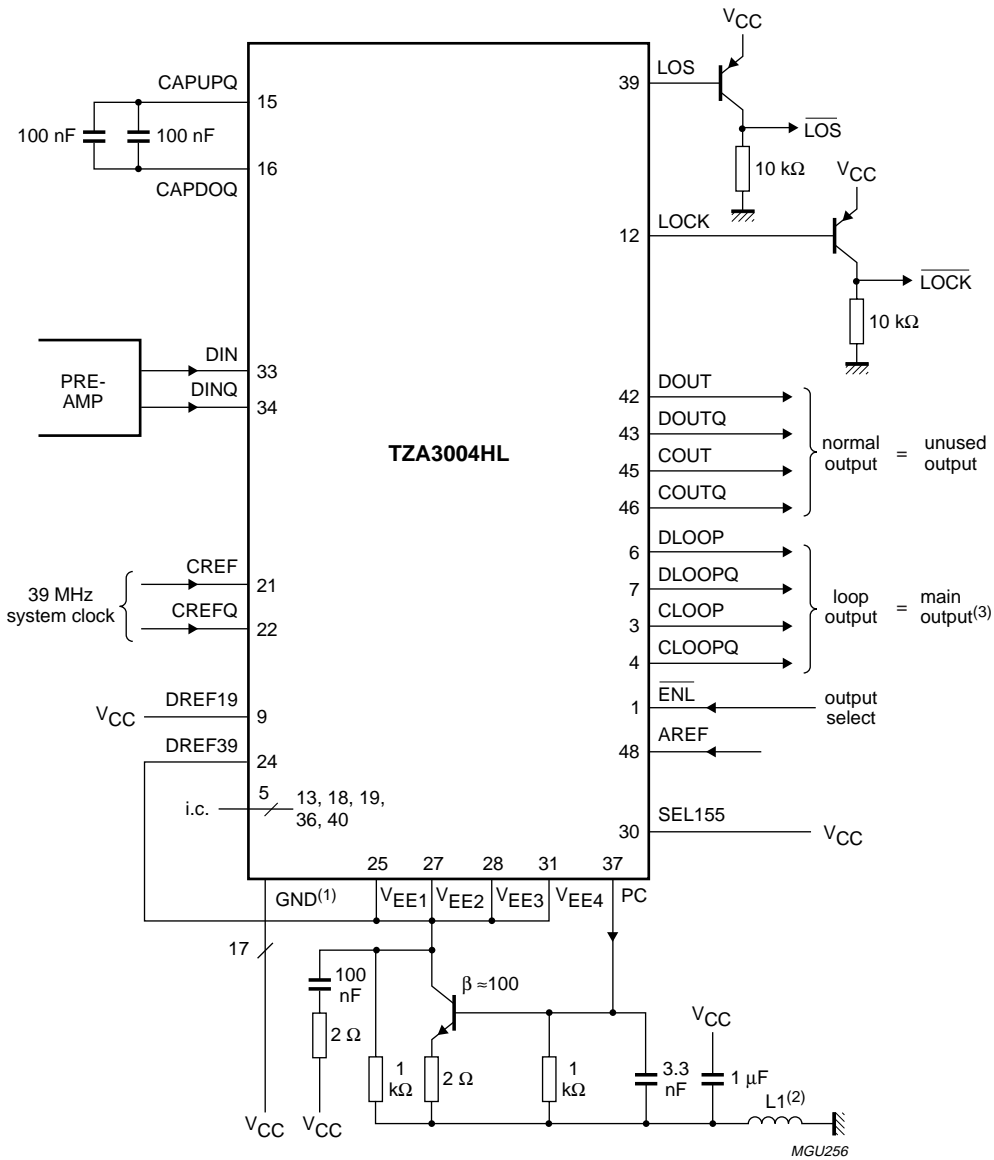

- (1) (1) All pins GND must be connected directly to V_{CC} on the PCB plane of +5 V (pins 2, 5, 8, 10, 11, 14, 17, 20, 23, 26, 29, 32, 35, 38, 41, 44 and 47).
- (2) L1 = RF choke type Murata BLM201, 1 μH.
- (3) The loop mode outputs are used as main outputs:
pin ENL = HIGH-level selects loop mode outputs
pin ENL = LOW-level selects loop mode and normal mode outputs simultaneously.

Fig.22 Application diagram showing the TZA3004HL configured for the STM4/OC12 mode (622.08 Mbits/s) with a positive supply voltage application.

SDH/SONET data and clock recovery unit
STM1/4 OC3/12

TZA3004HL

PACKAGE OUTLINE

LQFP48: plastic low profile quad flat package; 48 leads; body 7 x 7 x 1.4 mm

SOT313-2

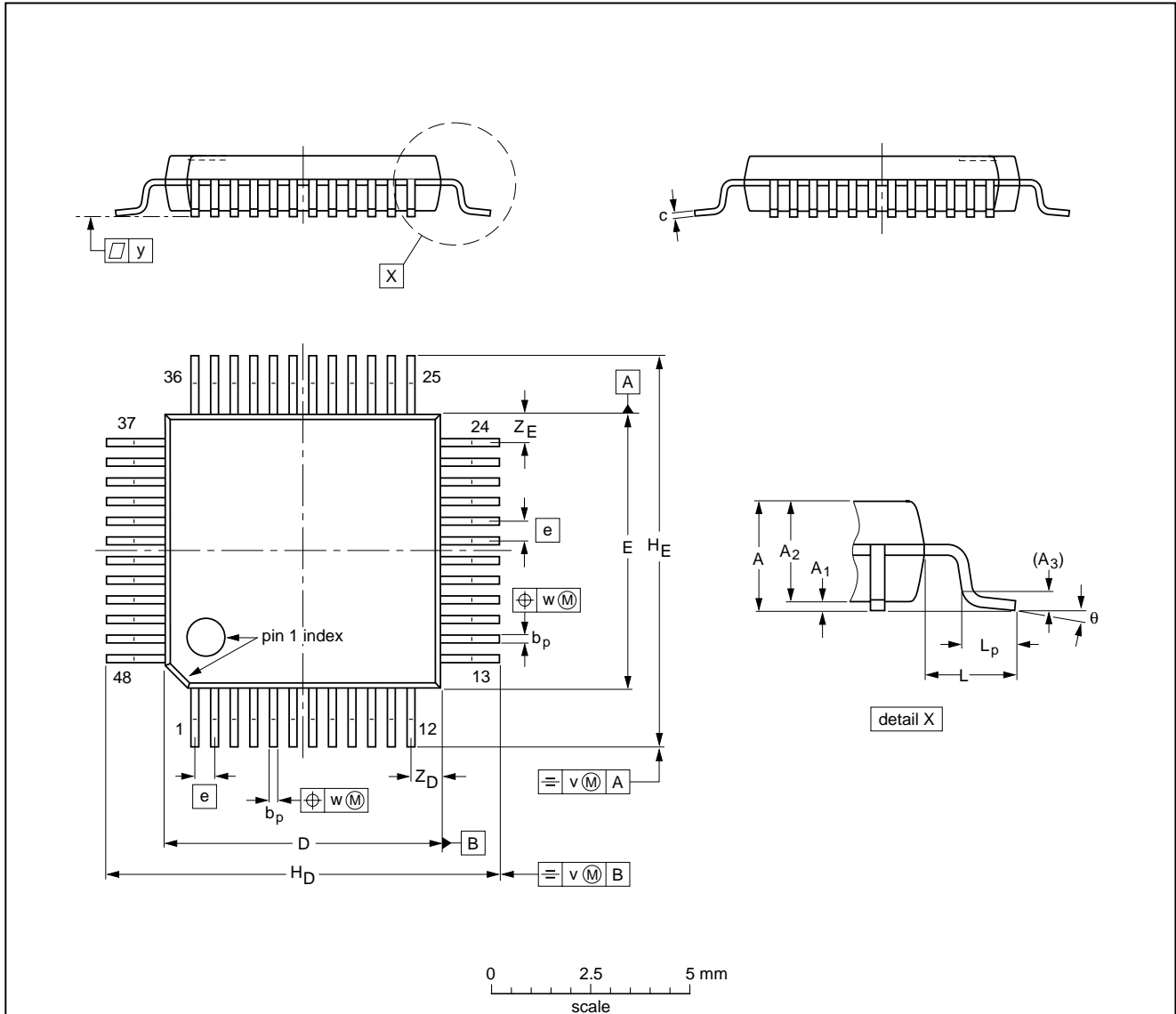

DIMENSIONS (mm are the original dimensions)

UNIT	A max.	A ₁	A ₂	A ₃	b _p	c	D ⁽¹⁾	E ⁽¹⁾	e	H _D	H _E	L	L _p	v	w	y	Z _D ⁽¹⁾	Z _E ⁽¹⁾	θ
mm	1.60	0.20 0.05	1.45 1.35	0.25	0.27 0.17	0.18 0.12	7.1 6.9	7.1 6.9	0.5	9.15 8.85	9.15 8.85	1.0	0.75 0.45	0.2	0.12	0.1	0.95 0.55	0.95 0.55	7° 0°

Note

1. Plastic or metal protrusions of 0.25 mm maximum per side are not included.

OUTLINE VERSION	REFERENCES				EUROPEAN PROJECTION	ISSUE DATE
	IEC	JEDEC	EIAJ			
SOT313-2	136E05	MS-026				99-12-27 00-01-19

SDH/SONET data and clock recovery unit STM1/4 OC3/12

TZA3004HL

SOLDERING

Introduction to soldering surface mount packages

This text gives a very brief insight to a complex technology. A more in-depth account of soldering ICs can be found in our *"Data Handbook IC26; Integrated Circuit Packages"* (document order number 9398 652 90011).

There is no soldering method that is ideal for all surface mount IC packages. Wave soldering can still be used for certain surface mount ICs, but it is not suitable for fine pitch SMDs. In these situations reflow soldering is recommended.

Reflow soldering

Reflow soldering requires solder paste (a suspension of fine solder particles, flux and binding agent) to be applied to the printed-circuit board by screen printing, stencilling or pressure-syringe dispensing before package placement.

Several methods exist for reflowing; for example, convection or convection/infrared heating in a conveyor type oven. Throughput times (preheating, soldering and cooling) vary between 100 and 200 seconds depending on heating method.

Typical reflow peak temperatures range from 215 to 250 °C. The top-surface temperature of the packages should preferably be kept below 220 °C for thick/large packages, and below 235 °C for small/thin packages.

Wave soldering

Conventional single wave soldering is not recommended for surface mount devices (SMDs) or printed-circuit boards with a high component density, as solder bridging and non-wetting can present major problems.

To overcome these problems the double-wave soldering method was specifically developed.

If wave soldering is used the following conditions must be observed for optimal results:

- Use a double-wave soldering method comprising a turbulent wave with high upward pressure followed by a smooth laminar wave.
- For packages with leads on two sides and a pitch (e):
 - larger than or equal to 1.27 mm, the footprint longitudinal axis is **preferred** to be parallel to the transport direction of the printed-circuit board;
 - smaller than 1.27 mm, the footprint longitudinal axis **must** be parallel to the transport direction of the printed-circuit board.

The footprint must incorporate solder thieves at the downstream end.

- For packages with leads on four sides, the footprint must be placed at a 45° angle to the transport direction of the printed-circuit board. The footprint must incorporate solder thieves downstream and at the side corners.

During placement and before soldering, the package must be fixed with a droplet of adhesive. The adhesive can be applied by screen printing, pin transfer or syringe dispensing. The package can be soldered after the adhesive is cured.

Typical dwell time is 4 seconds at 250 °C.

A mildly-activated flux will eliminate the need for removal of corrosive residues in most applications.

Manual soldering

Fix the component by first soldering two diagonally-opposite end leads. Use a low voltage (24 V or less) soldering iron applied to the flat part of the lead. Contact time must be limited to 10 seconds at up to 300 °C.

When using a dedicated tool, all other leads can be soldered in one operation within 2 to 5 seconds between 270 and 320 °C.

SDH/SONET data and clock recovery unit
STM1/4 OC3/12

TZA3004HL

Suitability of surface mount IC packages for wave and reflow soldering methods

PACKAGE	SOLDERING METHOD	
	WAVE	REFLOW ⁽¹⁾
BGA, LFBGA, SQFP, TFBGA	not suitable	suitable
HBCC, HLQFP, HSQFP, HSOP, HTQFP, HTSSOP, HVQFN, SMS	not suitable ⁽²⁾	suitable
PLCC ⁽³⁾ , SO, SOJ	suitable	suitable
LQFP, QFP, TQFP	not recommended ⁽³⁾⁽⁴⁾	suitable
SSOP, TSSOP, VSO	not recommended ⁽⁵⁾	suitable

Notes

1. All surface mount (SMD) packages are moisture sensitive. Depending upon the moisture content, the maximum temperature (with respect to time) and body size of the package, there is a risk that internal or external package cracks may occur due to vaporization of the moisture in them (the so called popcorn effect). For details, refer to the Drypack information in the *"Data Handbook IC26; Integrated Circuit Packages; Section: Packing Methods"*.
2. These packages are not suitable for wave soldering as a solder joint between the printed-circuit board and heatsink (at bottom version) can not be achieved, and as solder may stick to the heatsink (on top version).
3. If wave soldering is considered, then the package must be placed at a 45° angle to the solder wave direction. The package footprint must incorporate solder thieves downstream and at the side corners.
4. Wave soldering is only suitable for LQFP, TQFP and QFP packages with a pitch (e) equal to or larger than 0.8 mm; it is definitely not suitable for packages with a pitch (e) equal to or smaller than 0.65 mm.
5. Wave soldering is only suitable for SSOP and TSSOP packages with a pitch (e) equal to or larger than 0.65 mm; it is definitely not suitable for packages with a pitch (e) equal to or smaller than 0.5 mm.

SDH/SONET data and clock recovery unit

STM1/4 OC3/12

TZA3004HL

DATA SHEET STATUS

DATA SHEET STATUS	PRODUCT STATUS	DEFINITIONS ⁽¹⁾
Objective specification	Development	This data sheet contains the design target or goal specifications for product development. Specification may change in any manner without notice.
Preliminary specification	Qualification	This data sheet contains preliminary data, and supplementary data will be published at a later date. Philips Semiconductors reserves the right to make changes at any time without notice in order to improve design and supply the best possible product.
Product specification	Production	This data sheet contains final specifications. Philips Semiconductors reserves the right to make changes at any time without notice in order to improve design and supply the best possible product.

Note

1. Please consult the most recently issued data sheet before initiating or completing a design.

DEFINITIONS

Short-form specification — The data in a short-form specification is extracted from a full data sheet with the same type number and title. For detailed information see the relevant data sheet or data handbook.

Limiting values definition — Limiting values given are in accordance with the Absolute Maximum Rating System (IEC 60134). Stress above one or more of the limiting values may cause permanent damage to the device. These are stress ratings only and operation of the device at these or at any other conditions above those given in the Characteristics sections of the specification is not implied. Exposure to limiting values for extended periods may affect device reliability.

Application information — Applications that are described herein for any of these products are for illustrative purposes only. Philips Semiconductors make no representation or warranty that such applications will be suitable for the specified use without further testing or modification.

DISCLAIMERS

Life support applications — These products are not designed for use in life support appliances, devices, or systems where malfunction of these products can reasonably be expected to result in personal injury. Philips Semiconductors customers using or selling these products for use in such applications do so at their own risk and agree to fully indemnify Philips Semiconductors for any damages resulting from such application.

Right to make changes — Philips Semiconductors reserves the right to make changes, without notice, in the products, including circuits, standard cells, and/or software, described or contained herein in order to improve design and/or performance. Philips Semiconductors assumes no responsibility or liability for the use of any of these products, conveys no licence or title under any patent, copyright, or mask work right to these products, and makes no representations or warranties that these products are free from patent, copyright, or mask work right infringement, unless otherwise specified.

SDH/SONET data and clock recovery unit
STM1/4 OC3/12

TZA3004HL

NOTES

SDH/SONET data and clock recovery unit
STM1/4 OC3/12

TZA3004HL

NOTES

SDH/SONET data and clock recovery unit
STM1/4 OC3/12

TZA3004HL

NOTES

Philips Semiconductors – a worldwide company

Argentina: see South America

Australia: 3 Figtree Drive, HOME BUSH, NSW 2140,
Tel. +61 2 9704 8141, Fax. +61 2 9704 8139

Austria: Computerstr. 6, A-1101 WIEN, P.O. Box 213,
Tel. +43 1 60 101 1248, Fax. +43 1 60 101 1210

Belarus: Hotel Minsk Business Center, Bld. 3, r. 1211, Volodarski Str. 6,
220050 MINSK, Tel. +375 172 20 0733, Fax. +375 172 20 0773

Belgium: see The Netherlands

Brazil: see South America

Bulgaria: Philips Bulgaria Ltd., Energoproject, 15th floor,
51 James Bourchier Blvd., 1407 SOFIA,
Tel. +359 2 68 9211, Fax. +359 2 68 9102

Canada: PHILIPS SEMICONDUCTORS/COMPONENTS,
Tel. +1 800 234 7381, Fax. +1 800 943 0087

China/Hong Kong: 501 Hong Kong Industrial Technology Centre,
72 Tat Chee Avenue, Kowloon Tong, HONG KONG,
Tel. +852 2319 7888, Fax. +852 2319 7700

Colombia: see South America

Czech Republic: see Austria

Denmark: Sydhavnsgade 23, 1780 COPENHAGEN V,
Tel. +45 33 29 3333, Fax. +45 33 29 3905

Finland: Sinikalliontie 3, FIN-02630 ESPOO,
Tel. +358 9 615 800, Fax. +358 9 6158 0920

France: 51 Rue Carnot, BP317, 92156 SURESNES Cedex,
Tel. +33 1 4099 6161, Fax. +33 1 4099 6427

Germany: Hammerbrookstraße 69, D-20097 HAMBURG,
Tel. +49 40 2353 60, Fax. +49 40 2353 6300

Hungary: see Austria

India: Philips INDIA Ltd, Band Box Building, 2nd floor,
254-D, Dr. Annie Besant Road, Worli, MUMBAI 400 025,
Tel. +91 22 493 8541, Fax. +91 22 493 0966

Indonesia: PT Philips Development Corporation, Semiconductors Division,
Gedung Philips, Jl. Buncit Raya Kav.99-100, JAKARTA 12510,
Tel. +62 21 794 0040 ext. 2501, Fax. +62 21 794 0080

Ireland: Newstead, Clonskeagh, DUBLIN 14,
Tel. +353 1 7640 000, Fax. +353 1 7640 200

Israel: RAPAC Electronics, 7 Kehilat Saloniki St, PO Box 18053,
TEL AVIV 61180, Tel. +972 3 645 0444, Fax. +972 3 649 1007

Italy: PHILIPS SEMICONDUCTORS, Via Casati, 23 - 20052 MONZA (MI),
Tel. +39 039 203 6838, Fax +39 039 203 6800

Japan: Philips Bldg 13-37, Kohnan 2-chome, Minato-ku,
TOKYO 108-8507, Tel. +81 3 3740 5130, Fax. +81 3 3740 5057

Korea: Philips House, 260-199 Itaewon-dong, Yongsan-ku, SEOUL,
Tel. +82 2 709 1412, Fax. +82 2 709 1415

Malaysia: No. 76 Jalan Universiti, 46200 PETALING JAYA, SELANGOR,
Tel. +60 3 750 5214, Fax. +60 3 757 4880

Mexico: 5900 Gateway East, Suite 200, EL PASO, TEXAS 79905,
Tel. +9-5 800 234 7381, Fax +9-5 800 943 0087

Middle East: see Italy

Netherlands: Postbus 90050, 5600 PB EINDHOVEN, Bldg. VB,
Tel. +31 40 27 82785, Fax. +31 40 27 88399

New Zealand: 2 Wagener Place, C.P.O. Box 1041, AUCKLAND,
Tel. +64 9 849 4160, Fax. +64 9 849 7811

Norway: Box 1, Manglerud 0612, OSLO,
Tel. +47 22 74 8000, Fax. +47 22 74 8341

Pakistan: see Singapore

Philippines: Philips Semiconductors Philippines Inc.,
106 Valero St. Salcedo Village, P.O. Box 2108 MCC, MAKATI,
Metro MANILA, Tel. +63 2 816 6380, Fax. +63 2 817 3474

Poland: Al.Jerozolimskie 195 B, 02-222 WARSAW,
Tel. +48 22 5710 000, Fax. +48 22 5710 001

Portugal: see Spain

Romania: see Italy

Russia: Philips Russia, Ul. Usatcheva 35A, 119048 MOSCOW,
Tel. +7 095 755 6918, Fax. +7 095 755 6919

Singapore: Lorong 1, Toa Payoh, SINGAPORE 319762,
Tel. +65 350 2538, Fax. +65 251 6500

Slovakia: see Austria

Slovenia: see Italy

South Africa: S.A. PHILIPS Pty Ltd., 195-215 Main Road Martindale,
2092 JOHANNESBURG, P.O. Box 58088 Newville 2114,
Tel. +27 11 471 5401, Fax. +27 11 471 5398

South America: Al. Vicente Pinzon, 173, 6th floor,
04547-130 SÃO PAULO, SP, Brazil,
Tel. +55 11 821 2333, Fax. +55 11 821 2382

Spain: Balmes 22, 08007 BARCELONA,
Tel. +34 93 301 6312, Fax. +34 93 301 4107

Sweden: Kottbygatan 7, Akalla, S-16485 STOCKHOLM,
Tel. +46 8 5985 2000, Fax. +46 8 5985 2745

Switzerland: Allmendstrasse 140, CH-8027 ZÜRICH,
Tel. +41 1 488 2741 Fax. +41 1 488 3263

Taiwan: Philips Semiconductors, 5F, No. 96, Chien Kuo N. Rd., Sec. 1,
TAIPEI, Taiwan Tel. +886 2 2134 2451, Fax. +886 2 2134 2874

Thailand: PHILIPS ELECTRONICS (THAILAND) Ltd.,
60/14 MOO 11, Bangna Trad Road KM. 3, Bagna, BANGKOK 10260,
Tel. +66 2 361 7910, Fax. +66 2 398 3447

Turkey: Yukari Dudullu, Org. San. Blg., 2.Cad. Nr. 28 81260 Umraniye,
ISTANBUL, Tel. +90 216 522 1500, Fax. +90 216 522 1813

Ukraine: PHILIPS UKRAINE, 4 Patrice Lumumba str., Building B, Floor 7,
252042 KIEV, Tel. +380 44 264 2776, Fax. +380 44 268 0461

United Kingdom: Philips Semiconductors Ltd., 276 Bath Road, Hayes,
MIDDLESEX UB3 5BX, Tel. +44 208 730 5000, Fax. +44 208 754 8421

United States: 811 East Arques Avenue, SUNNYVALE, CA 94088-3409,
Tel. +1 800 234 7381, Fax. +1 800 943 0087

Uruguay: see South America

Vietnam: see Singapore

Yugoslavia: PHILIPS, Trg N. Pasica 5/v, 11000 BEOGRAD,
Tel. +381 11 3341 299, Fax.+381 11 3342 553

For all other countries apply to: Philips Semiconductors,
Marketing Communications, Building BE-p, P.O. Box 218, 5600 MD EINDHOVEN,
The Netherlands, Fax. +31 40 27 24825

Internet: <http://www.semiconductors.philips.com>

© Philips Electronics N.V. 2000

SCA 70

All rights are reserved. Reproduction in whole or in part is prohibited without the prior written consent of the copyright owner.

The information presented in this document does not form part of any quotation or contract, is believed to be accurate and reliable and may be changed without notice. No liability will be accepted by the publisher for any consequence of its use. Publication thereof does not convey nor imply any license under patent- or other industrial or intellectual property rights.

Printed in The Netherlands

403510/50/02/pp32

Date of release: 2000 Nov 28

Document order number: 9397 750 07684

Let's make things better.

**Philips
Semiconductors**



PHILIPS