

Description

The TS8MLS64V6L is an 8M bit x 64 Synchronous Dynamic RAM high-density for PC-133. The TS8MLS64V6L consists of 8pcs CMOS 8Mx8 bits Synchronous DRAMs in TSOP-II 400mil packages and a 2048 bits serial EEPROM on a 168-pin printed circuit board. The TS8MLS64V6L is a Dual In-Line Memory Module and is intended for mounting into 168-pin edge connector sockets.

Synchronous design allows precise cycle control with the use of system clock. I/O transactions are possible on every clock cycle. Range of operation frequencies, programmable latencies allow the same device to be useful for a variety of high bandwidth, high performance memory system applications.

Features

- Performance Range: PC-133.
- Conformed to JEDEC Standard spec.
- Burst Mode Operation.
- Auto and Self Refresh.
- CKE Power Down Mode.
- DQM Byte Masking (Read/Write)
- Serial Presence Detect (SPD) with serial EEPROM
- LVTTTL compatible inputs and outputs.
- Single $3.3V \pm 0.3V$ power supply.
- MRS cycle with address key programs.
Latency (Access from column address)
Burst Length (1,2,4,8 & Full Page)
Data Sequence (Sequential & Interleave)
- All inputs are sampled at the positive going edge of the system clock.

Placement

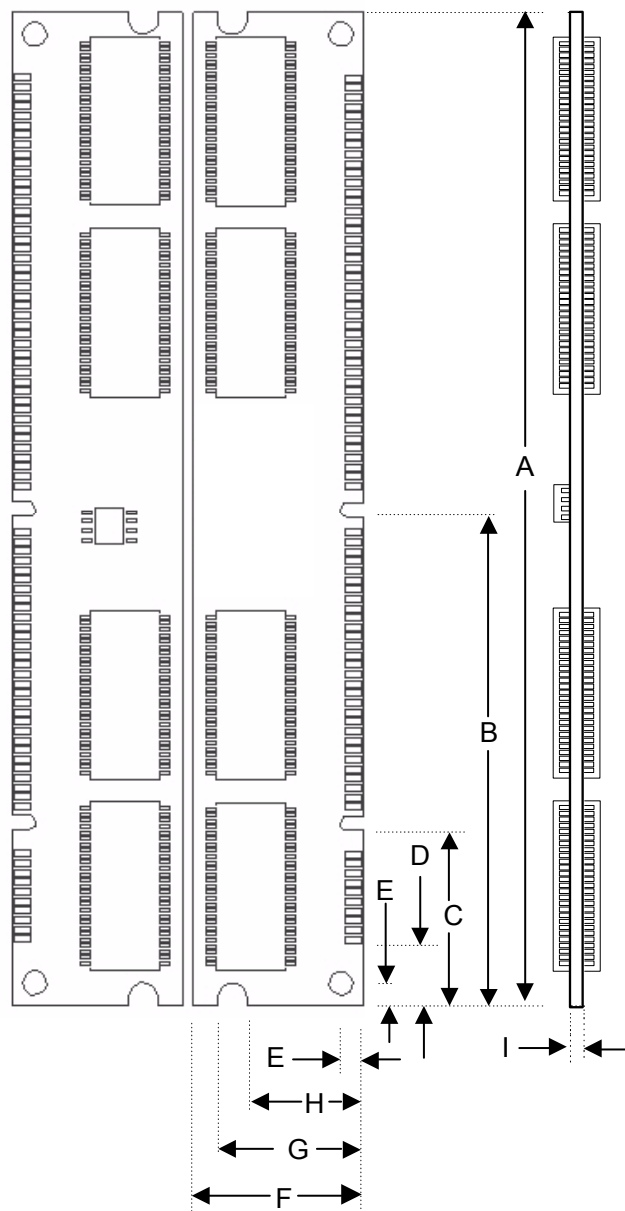

PCB: 09-1090

Dimensions

Side	Millimeters	Inches
A	133.35±0.40	5.250±0.016
B	65.67	2.585
C	23.49	0.925
D	8.89	0.350
E	3.00	0.118
F	23.00±0.20	0.91±0.008
G	19.80	0.788
H	15.80	0.622
I	1.27±0.10	0.050±0.004

(Refer Placement)

Pin Identification

Symbol	Function
A0~A11, BA0,BA1	Address input
DQ0~DQ63	Data Input / Output.
CLK0,CLK2	Clock Input.
CKE0	Clock Enable Input.
/CS0,/CS2	Chip Select Input.
/RAS	Row Address Strobe
/CAS	Column Address Strobe
/WE	Write Enable
DQM0~DQM7	Data (DQ) Mask
SA0~SA2	Address in EEPROM
SCL	Serial PD Clock
SDA	Serial PD Add/Data input/output
Vcc	+3.3 Voltage Power Supply
Vss	Ground
NC	No Connection

Pinouts:

Pin No	Pin Name	Pin No	Pin Name	Pin No	Pin Name	Pin No	Pin Name
01	Vss	43	Vss	85	Vss	127	Vss
02	DQ0	44	NC	86	DQ32	128	CKE0
03	DQ1	45	/CS2	87	DQ33	129	*/CS3
04	DQ2	46	DQM2	88	DQ34	130	DQM6
05	DQ3	47	DQM3	89	DQ35	131	DQM7
06	Vcc	48	NC	90	Vcc	132	*A13
07	DQ4	49	Vcc	91	DQ36	133	Vcc
08	DQ5	50	NC	92	DQ37	134	NC
09	DQ6	51	NC	93	DQ38	135	NC
10	DQ7	52	*CB2	94	DQ39	136	*CB6
11	DQ8	53	*CB3	95	DQ40	137	*CB7
12	Vss	54	Vss	96	Vss	138	Vss
13	DQ9	55	DQ16	97	DQ41	139	DQ48
14	DQ10	56	DQ17	98	DQ42	140	DQ49
15	DQ11	57	DQ18	99	DQ43	141	DQ50
16	DQ12	58	DQ19	100	DQ44	142	DQ51
17	DQ13	59	Vcc	101	DQ45	143	Vcc
18	Vcc	60	DQ20	102	Vcc	144	DQ52
19	DQ14	61	NC	103	DQ46	145	NC
20	DQ15	62	*Vref	104	DQ47	146	*Vref
21	*CB0	63	*CKE1	105	*CB4	147	*REGE
22	*CB1	64	Vss	106	*CB5	148	Vss
23	Vss	65	DQ21	107	Vss	149	DQ53
24	NC	66	DQ22	108	NC	150	DQ54
25	NC	67	DQ23	109	NC	151	DQ55
26	Vcc	68	Vss	110	Vcc	152	Vss
27	/WE	69	DQ24	111	/CAS	153	DQ56
28	DQM0	70	DQ25	112	DQM4	154	DQ57
29	DQM1	71	DQ26	113	DQM5	155	DQ58
30	/CS0	72	DQ27	114	*/CS1	156	DQ59
31	NC	73	Vcc	115	/RAS	157	Vcc
32	Vss	74	DQ28	116	Vss	158	DQ60
33	A0	75	DQ29	117	A1	159	DQ61
34	A2	76	DQ30	118	A3	160	DQ62
35	A4	77	DQ31	119	A5	161	DQ63
36	A6	78	Vss	120	A7	162	Vss
37	A8	79	*CLK2	121	A9	163	*CLK3
38	A10/AP	80	NC	122	BA0	164	NC
39	BA1	81	NC	123	A11	165	SA0
40	Vcc	82	SDA	124	Vcc	166	SA1
41	Vcc	83	SCL	125	*CLK1	167	SA2
42	CLK0	84	Vcc	126	*A12	168	Vcc

* Please refer Block Diagram

Block Diagram

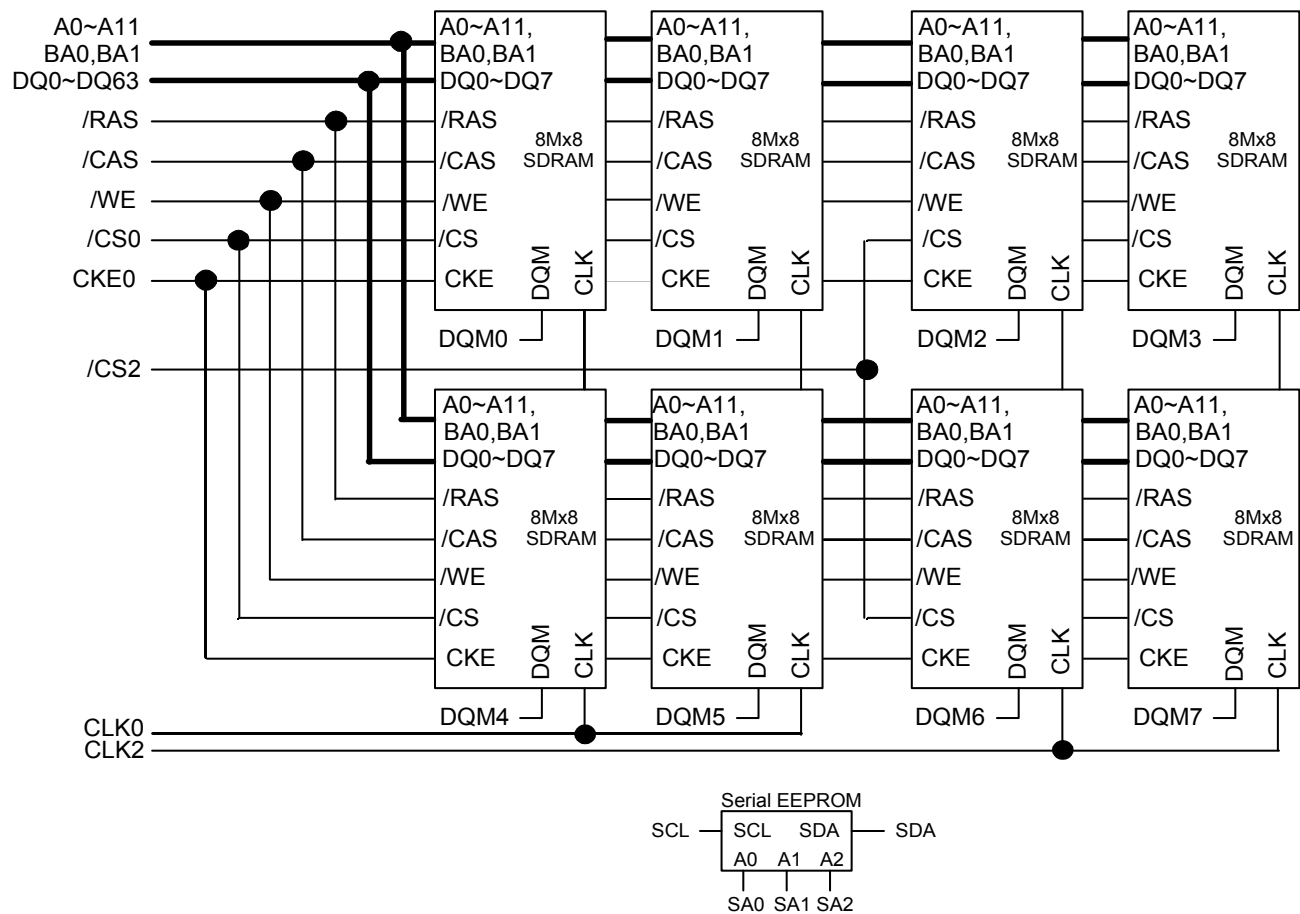

This technical information is based on industry standard data and tests believed to be reliable. However, Transcend makes no warranties, either expressed or implied, as to its accuracy and assume no liability in connection with the use of this product. Transcend reserves the right to make changes in specifications at any time without prior notice.

ABSOLUTE MAXIMUM RATINGS

Parameter	Symbol	Value	Unit
Voltage on any pin relative to Vss	V _{IN} , V _{OUT}	-1.0~4.6	V
Voltage on VDD supply to Vss	VDD, VDDQ	-1.0~4.6	V
Storage temperature	TSTG	-55~+150	°C
Power dissipation	P _D	8	W
Short circuit current	I _{OS}	50	mA
Mean time between failure	MTBF	50	year
Temperature Humidity Burning	THB	85°C/85%, Static Stress	°C-%
Temperature Cycling Test	TC	0°C ~ 125°C Cycling	°C

Note: Permanent device damage may occur if ABSOLUTE MAXIMUM RATINGS are exceeded. Functional operation should be restricted to recommended operating condition. Exposure to higher than recommended voltage for extended periods of time could affect device reliability.

DC OPERATING CONDITIONS AND CHARACTERISTICS

Recommended operating conditions (Voltage referenced to Vss = 0V, TA = 0 to 70°C)

Parameter	Symbol	Min	Typ	Max	Unit	Note
Supply voltage	VDD	3.0	3.3	3.6	V	
Input high voltage	V _{IH}	2.0	3.0	VDD+0.3	V	1
Input low voltage	V _{IL}	-0.3	0	0.8	V	2
Output high voltage	V _{OH}	2.4	-	-	V	I _{OH} =-2mA
Output low voltage	V _{OL}	-	-	0.4	V	I _{OL} =2mA
Input leakage current (Inputs)	I _{IL}	-10	-	10	uA	3

Note: 1. V_{IH} (max) = 5.6V AC. The overshoot voltage duration is ≤ 3ns.
2. V_{IL} (min) = -2.0V AC. The undershoot voltage duration is ≤ 3ns.
3. Any input 0V ≤ V_{IN} ≤ VDDQ.
Input leakage currents include Hi-Z output leakage for all bi-directional buffers with Tri-State outputs.

CAPACITANCE (TA = 25°C, f = 1MHz)

Parameter	Symbol	Min	Max	Unit
Input capacitance (A0~A11, BA0~ BA1)	C _{IN1}	25	45	pF
Input capacitance (/RAS, /CAS, /WE)	C _{IN2}	25	45	pF
Input capacitance (CKE0)	C _{IN3}	25	45	pF
Input capacitance (CLK0, CLK2)	C _{IN4}	15	30	pF
Input capacitance (/CS0, /CS2)	C _{IN5}	15	25	pF
Input capacitance (DQM0~DQM7)	C _{IN6}	8	12	pF
Data input/output capacitance (DQ0~DQ63)	C _{OUT}	9	12	pF

DC CHARACTERISTICS

(Recommended operating condition unless otherwise noted, TA = 0 to 70°C)

Parameter	Symbol	Test Condition	Value	Unit	Note
Operating Current (One Bank Active)	ICC1	Burst Length =1 tRC≥tRC(min) IOL=0mA	600	mA	1
Precharge Standby Current in power-down mode	ICC2P	CKE≤VIL(max), tCC=10ns	8	mA	
	ICC2PS	CKE & CLK≤VIL(max), tCC=∞	8		
Precharge Standby Current in non power-down mode	ICC2N	CKE≥VIH(min), /CS≥VIH(min), tCC=10ns Input signals are changed one time during 30ns	120	mA	
	ICC2NS	CKE≥VIH(min), CLK≤VIL(max), tCC=∞ Input signals are stable	48		
Active Standby Current in power-down mode	ICC3P	CKE≤VIL(max), tCC=10ns	24	mA	
	ICC3PS	CKE & CLK≤VIL(max), tCC=∞	24		
Active Standby Current in non power-down mode (One Bank Active)	ICC3N	CKE≥VIH(min), /CS≥VIH(min), tCC=10ns Input signals are changed one time during 30ns	240	mA	
	ICC3NS	CKE≥VIH(min), CLK≤VIL(max), tCC=∞ Input signals are stable	200		
Operating Current (Burst Mode)	ICC4	IOL= 0 mA Page Burst tCCD = 2CLKs	920	mA	1
Refresh Current	ICC5	tRC≥tRC(min)	1,080	mA	2
Self Refresh Current	ICC6	CKE≤0.2V	8	mA	

Note: 1. Measured with outputs open.
2. Refresh period is 64ms.
3. Unless otherwise noticed, input swing level is CMOS (VIH/VIL=VDDQ/VSSQ)

AC OPERATING TEST CONDITIONS ($V_{DD} = 3.3V \pm 0.3V$, $T_A = 0$ to $70^\circ C$)

Parameter	Value	Unit
AC Input levels (V_{IH}/V_{IL})	2.4/0.4	V
Input timing measurement reference level	1.4	V
Input rise and fall time	$t_r/t_f=1/1$	ns
Output timing measurement reference level	1.4	V
Output load condition	See Fig. 2	

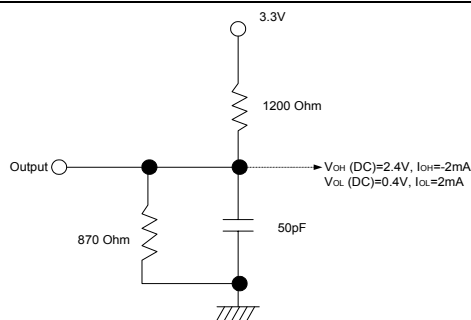

(Fig. 1) DC Output Load Circuit

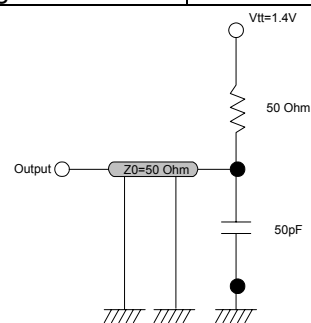

(Fig. 2) AC Output Load Circuit

OPERATING AC PARAMETER (AC operating conditions unless otherwise noted)

Parameter	Symbol	Value	Unit	Note
Row active to row active delay	$t_{RRD}(\min)$	15	ns	1
/RAS to /CAS delay	$t_{RCD}(\min)$	20	ns	1
Row precharge time	$t_{RP}(\min)$	20	ns	1
Row active time	$t_{RAS}(\min)$	45	ns	1
	$t_{RAS}(\max)$	100	us	
Row cycle time	$t_{RC}(\min)$	65	ns	1
Last data in to new col. address delay	$t_{CDL}(\min)$	1	CLK	2
Last data in to row precharge	$t_{RDL}(\min)$	2	CLK	2
Last data in to Active delay	$t_{DAL}(\min)$	$2CLK+t_{RP}$	-	
Last data in to burst stop	$t_{BDL}(\min)$	1	CLK	2
Col. address to col. address delay	$t_{CCD}(\min)$	1	CLK	3
Number of valid output data	CAS latency=3	2	ea	4
	-	-		

- Note:**
1. The minimum number of clock cycles is determined by dividing the minimum time required with clock cycle time, and then rounding off to the next higher integer.
 2. Minimum delay is required to complete write.
 3. All parts allow every cycle column address change.
 4. In case of row precharge interrupt, auto precharge and read burst stop.

AC CHARACTERISTICS (AC operating conditions unless otherwise noted)

Refer to the individual component, not the whole module.

Parameter	Symbol	(value)Min	(Value)Max	Unit	Note
CLK cycle time	tcc	7.5	1000	ns	1
CLK to valid output delay	tsAC		5.4	ns	1, 2
Output data hold time	tOH	3		ns	2
CLK high pulse width	tCH	2.5		ns	3
CLK low pulse width	tCL	2.5		ns	3
Input setup time	tSS	1.5		ns	3
Input hold time	tSH	0.8		ns	3
CLK to output in Low-Z	tSLZ	1		ns	2
CLK to output in Hi-Z	tSHZ		5.4	ns	

- Note:**
- Parameters depend on programmed CAS latency.
 - If clock rising time is longer than 1ns, $(tr/2-0.5)$ ns should be added to the parameter.
 - Assumed input rise and fall time (tr & tf)= 1ns.
If tr & tf is longer than 1ns, transient time compensation should be considered,
i.e., $[(tr + tf)/2-1]$ ns should be added to the parameter.

SIMPLIFIED TRUTH TABLE

(V=Valid, X=Don't Care, H=Logic High, L=Logic Low)

COMMAND		CKEn-1	CKEn	/CS	/RAS	/CAS	/WE	DQM	BA0,1	A10/AP	A0~A9, A11	Note
Register	Mode Register Set	H	X	L	L	L	L	X	OP CODE			1,2
Refresh	Auto Refresh	H	H	L	L	L	H	X	X			3
	Entry		L									3
	Self Refresh	L	H	L	H	H	H	X	X			3
Exit	H			X	X	X	3					
Bank Active & Row Addr.		H	X	L	L	H	H	X	V	Row Address		
Read & Column Address	Auto Precharge Disable	H	X	L	H	L	H	X	V	L	Column Address (A0~A8)	4
	Auto Precharge Enable									H		4, 5
Write & Column Address	Auto Precharge Disable	H	X	L	H	L	L	X	V	L	Column Address (A0~A8)	4
	Auto Precharge Enable									H		4, 5
Burst Stop		H	X	L	H	H	L	X	X			6
Precharge	Bank Selection	H	X	L	L	H	L	X	V	L	X	
	Both Banks								X	H		
Clock Suspend or Active Power Down	Entry	H	L	H	X	X	X	X	X			
				L	V	V	V					
	Exit	L	H	X	X	X	X	X				
Precharge Power Down Mode	Entry	H	L	H	X	X	X	X	X			
				L	H	H	H					
	Exit	L	H	H	X	X	X	X				
				L	V	V	V					
DQM		H	X					V	X			7
No Operation Command		H	X	H	X	X	X	X	X			
				L	H	H	H					

Note:

- OP Code: Operand Code
A0~A11, BA0~BA1: Program keys. (@MRS)
- MRS can be issued only at both banks precharge state.
A new command can be issued after 2 CLK cycles of MRS.
- Auto refresh functions are as same as CBR refresh of DRAM.
The automatically precharge without row precharge command is meant by "Auto".
Auto/self refresh can be issued only at both banks precharge state.
- BA0~BA1: Bank select address.
If both BA0 and BA1 are "Low" at read, write, row active and precharge, bank A is selected.
If both BA0 is "Low" and BA1 is "High" at read, write, row active and precharge, bank B is selected.
If both BA0 is "High" and BA1 is "Low" at read, write, row active and precharge, bank C is selected.
If both BA0 and BA1 are "High" at read, write, row active and precharge, bank D is selected.
If A10/AP is "High" at row precharge, BA0 and BA1 are ignored and both banks are selected.
- During burst read or write with auto precharge, new read/write command cannot be issued.
Another bank read/write command can be issued after the end of burst.
New row active of the associated bank can be issued at tRP after the end of burst.
- Burst stop command is valid at every burst length.
- DQM sampled at positive going edged of a CLK masks the data-in at the very CLK (Write DQM latency is 0), but makes Hi-Z state the data-out of 2 CLK cycles after. (Read DQM latency is 2)

Serial Presence Detect Specification

Serial Presence Detect								
Byte No.	Function Described	Standard Specification	Vendor Part					
0	Number of Bytes Written into Serial Memory	128bytes	80					
1	Total Number of Bytes of S.P.D Memory	256bytes	08					
2	Fundamental Memory Type	SDRAM	04					
3	Number of Row Addresses on this Assembly	12	0C					
4	Number of Column Addresses on this Assembly	9	09					
5	Number of Module Banks on this Assembly	1 bank	01					
6	Data Width of this Assembly	64bits	40					
7	Data Width Continuation	0	00					
8	Voltage Interface Standard of this Assembly	LVTTTL3.3V	01					
9	SDRAM Cycle Time (highest CAS latency)	7.5ns	75					
10	SDRAM Access from Clock (highest CL)	5.4ns	54					
11	DIMM configuration type (non-parity, ECC)	None	00					
12	Refresh Rate Type	15.625us/Self Refresh	80					
13	Primary SDRAM Width	X8	08					
14	Error Checking SDRAM Width	None	00					
15	Min Clock Delay Back to Back Random Address	1 clock	01					
16	Burst Lengths Supported	1,2,4,8 & Full page	8F					
17	Number of banks on each SDRAM device	4 bank	04					
18	CAS # Latency	3	04					
19	CS # Latency	0 clock	01					
20	Write Latency	0 clock	01					
21	SDRAM Module Attributes	Non Buffer	00					
22	SDRAM Device Attributes : General	Prec All, Auto Prec, R/W Burst	0E					
23	SDRAM Cycle Time (2 nd highest CL)	0	00					
24	SDRAM Access from Clock (2 nd highest CL)	0	00					
25	SDRAM Cycle Time (3 rd highest CL)	0	00					
26	SDRAM Access from Clock (3 rd highest CL)	0	00					
27	Minimum Row Precharge Time	20ns	14					
28	Minimum Row Active to Row Activate	15ns	0F					
29	Minimum RAS to CAS Delay	20ns	14					
30	Minimum RAS Pulse Width	45ns	2D					
31	Density of Each Bank on Module	64MB	10					
32	Command/Address Setup Time	1.5ns	15					
33	Command/Address Hold Time	0.8ns	08					
34	Data Signal Setup Time	1.5ns	15					
35	Data Signal Hold Time	0.8ns	08					
36-61	Superset Information	-	00					
62	SPD Data Revision Code	JEDEC2	02					
63	Checksum for Bytes 0-62	-	8C					
64-71	Manufacturers JEDEC ID Code per JEP-108E	Transcend	7F, 4F					
72	Man Manufacturers manufacturing Location	T	54					
73-90	Part Number	TS8MLS64V6L	54	53	38	4D	4C	53
			36	34	56	36	4C	20
			20	20	20	20	20	20
91-92	Revision Code	-	0					

TS8MLS64V6L

168Pin PC133 Unbuffered DIMM
64MB With 8Mx8 CL3

93-94	Manufacturing Date	By Manufacturer	Variable
95-98	Assembly Serial Number	By Manufacturer	Variable
99-125	Manufacturer Specific Data	-	0
126	Intel Specification Frequency	-	64
127	Intel Specification CAS# Latency/Clock Signal Support	CL=3 Clock 0,2	A4
128~	Unused Storage Locations	Open	FF