

### **Rochester Electronics Manufactured Components**

Rochester branded components are manufactured using either die/wafers purchased from the original suppliers or Rochester wafers recreated from the original IP. All recreations are done with the approval of the OCM.

Parts are tested using original factory test programs or Rochester developed test solutions to guarantee product meets or exceed the OCM data sheet.

### **Quality Overview**

- ISO-9001
- AS9120 certification
- Qualified Manufacturers List (QML) MIL-PRF-35835
  - Class Q Military
  - Class V Space Level
- Qualified Suppliers List of Distributors (QSLD)
  - Rochester is a critical supplier to DLA and meets all industry and DLA standards.

Rochester Electronics, LLC is committed to supplying products that satisfy customer expectations for quality and are equal to those originally supplied by industry manufacturers.

---

The original manufacturer's datasheet accompanying this document reflects the performance and specifications of the Rochester manufactured version of this device. Rochester Electronics guarantees the performance of its semiconductor products to the original OEM specifications. 'Typical' values are for reference purposes only. Certain minimum or maximum ratings may be based on product characterization, design, simulation, or sample testing.

# LM193, LM293, LM293A, LM393 LM393A, LM393Y, LM2903, LM2903Q DUAL DIFFERENTIAL COMPARATORS

SLCS005D – JUNE 1976 – REVISED JULY 1998

- Single Supply or Dual Supplies
- Wide Range of Supply Voltage . . . 2 V to 36 V
- Low Supply-Current Drain Independent of Supply Voltage . . . 0.5 mA Typ
- Low Input Bias Current . . . 25 nA Typ
- Low Input Offset Current . . . 3 nA Typ (LM193)
- Low Input Offset Voltage . . . 2 mV Typ
- Common-Mode Input Voltage Range Includes Ground
- Differential Input Voltage Range Equal to Maximum-Rated Supply Voltage . . .  $\pm 36$  V
- Low Output Saturation Voltage
- Output Compatible With TTL, MOS, and CMOS

## description

These devices consist of two independent voltage comparators that are designed to operate from a single power supply over a wide range of voltages. Operation from dual supplies also is possible as long as the difference between the two supplies is 2 V to 36 V and  $V_{CC}$  is at least 1.5 V more positive than the input common-mode voltage. Current drain is independent of the supply voltage. The outputs can be connected to other open-collector outputs to achieve wired-AND relationships.

The LM193 is characterized for operation from  $-55^{\circ}\text{C}$  to  $125^{\circ}\text{C}$ . The LM293 and LM293A are characterized for operation from  $-25^{\circ}\text{C}$  to  $85^{\circ}\text{C}$ . The LM393 and LM393A are characterized for operation from  $0^{\circ}\text{C}$  to  $70^{\circ}\text{C}$ . The LM2903 and LM2903Q are characterized for operation from  $-40^{\circ}\text{C}$  to  $125^{\circ}\text{C}$  and is manufactured to demanding automotive requirements.

## logic diagram (each comparator)



D, JG, P, OR PW PACKAGE  
(TOP VIEW)

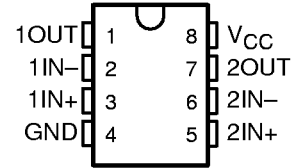

FK PACKAGE  
(TOP VIEW)

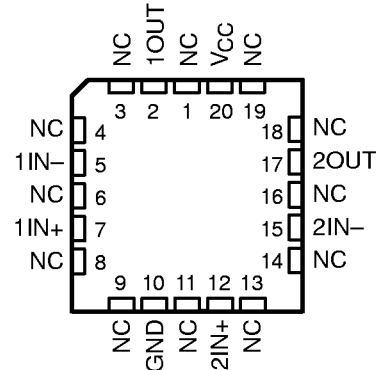

NC – No internal connection



Please be aware that an important notice concerning availability, standard warranty, and use in critical applications of Texas Instruments semiconductor products and disclaimers thereto appears at the end of this data sheet.

PRODUCTION DATA information is current as of publication date. Products conform to specifications per the terms of Texas Instruments standard warranty. Production processing does not necessarily include testing of all parameters.

**TEXAS  
INSTRUMENTS**

POST OFFICE BOX 655303 • DALLAS, TEXAS 75265

Copyright © 1998, Texas Instruments Incorporated

# LM193, LM293, LM293A, LM393 LM393A, LM393Y, LM2903, LM2903Q DUAL DIFFERENTIAL COMPARATORS

SLCS005D – JUNE 1976 – REVISED JULY 1998

## AVAILABLE OPTIONS

T <sub>A</sub>	V <sub>IO(max)</sub> AT 25°C	PACKAGED DEVICES					CHIP FORM (Y)§
		SMALL OUTLINE (D)†	CHIP CARRIER (FK)	CERAMIC DIP (JG)	PLASTIC DIP (P)	TSSOP (PW)‡	
0°C to 70°C	5 mV	LM393D	—	—	LM393P	LM393PW	LM393Y
	2 mV	LM393AD	—	—	LM393AP	—	—
-25°C to 85°C	5 mV	LM293D	—	—	LM293P	—	—
	2 mV	LM293AD	—	—	LM293AP	—	—
-40°C to 125°C	7 mV	LM2903D	—	—	LM2903P	LM2903PW	—
		LM2903QD	—	—	LM2903QP	—	—
-55°C to 125°C	5 mV	LM193D	LM193FK	LM193JG	LM193P	—	—

† The D package is available taped and reeled. Add the suffix R (e.g., LM393DR).

‡ The PW package is only available left-end taped and reeled.

§ Chips are tested at 25°C (see LM393Y for electrical characteristics).

## LM393Y chip information

This chip, when properly assembled, displays characteristics similar to the LM393. Thermal compression or ultrasonic bonding can be used on the doped-aluminum bonding pads. Chips can be mounted with conductive epoxy or a gold-silicon preform.

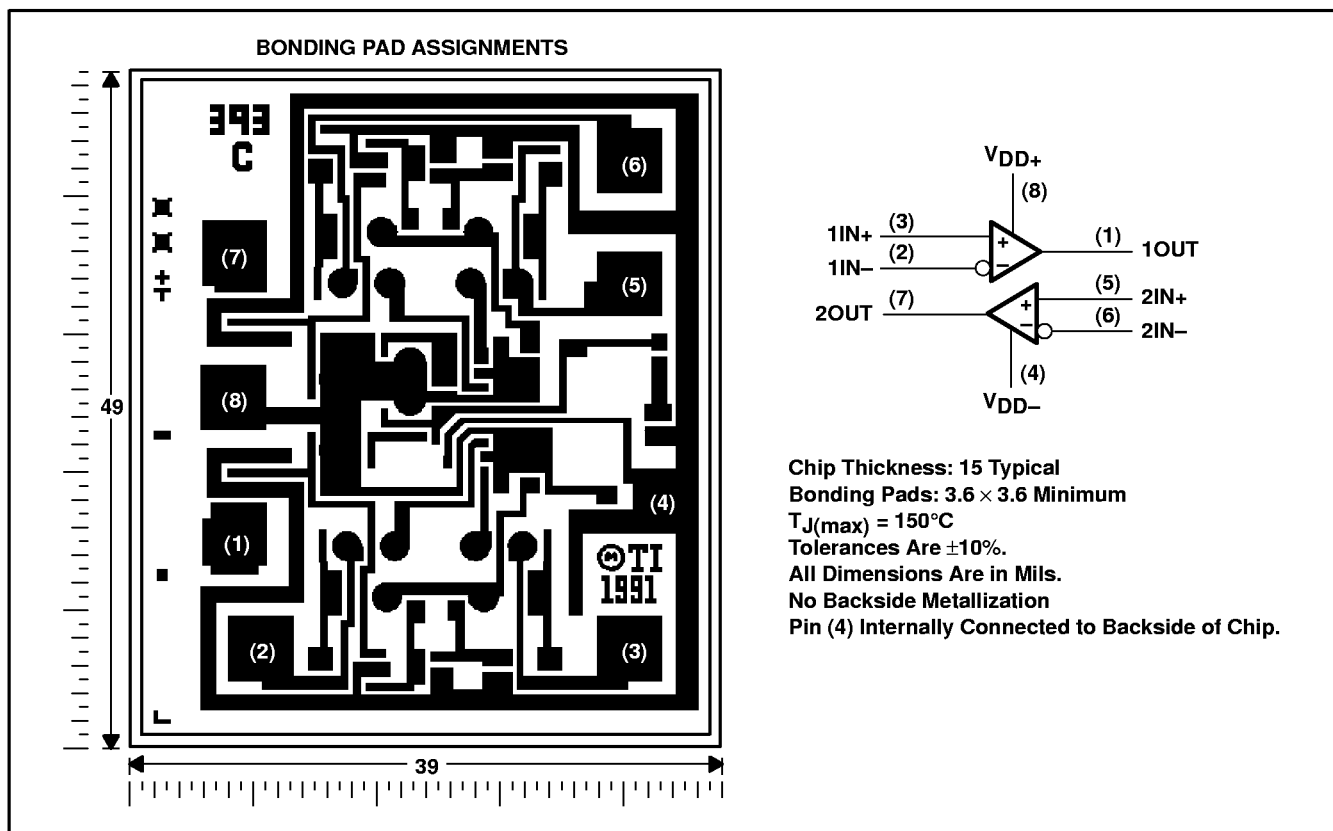

**LM193, LM293, LM293A, LM393**  
**LM393A, LM393Y, LM2903, LM2903Q**  
**DUAL DIFFERENTIAL COMPARATORS**

SLCS005D – JUNE 1976 – REVISED JULY 1998

**schematic (each comparator)**

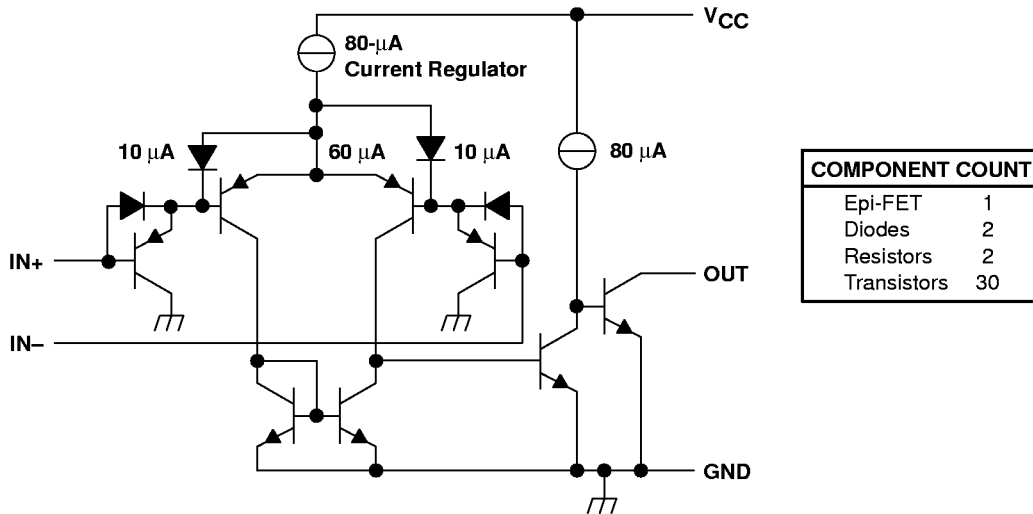

Current values shown are nominal.

**absolute maximum ratings over operating free-air temperature range (unless otherwise noted)†**

Supply voltage, $V_{CC}$ (see Note 1)	36 V
Differential input voltage, $V_{ID}$ (see Note 2)	$\pm 36$ V
Input voltage range, $V_I$ (either input)	-0.3 V to 36 V
Output voltage, $V_O$	36 V
Output current, $I_O$	20 mA
Duration of output short-circuit to ground (see Note 3)	unlimited
Continuous total power dissipation	See Dissipation Rating Table
Operating free-air temperature range, $T_A$ : LM193	-55°C to 125°C
LM293, LM293A	-25°C to 85°C
LM393, LM393A	0°C to 70°C
LM2903, LM2903Q	-40°C to 125°C
Storage temperature range, $T_{stg}$	-65°C to 150°C
Case temperature for 60 seconds: FK package	260°C
Lead temperature 1,6 mm (1/16 inch) from case for 10 seconds: D, P, or PW package	260°C
Lead temperature 1,6 mm (1/16 inch) from case for 60 seconds: JG package	300°C

† Stresses beyond those listed under "absolute maximum ratings" may cause permanent damage to the device. These are stress ratings only, and functional operation of the device at these or any other conditions beyond those indicated under "recommended operating conditions" is not implied. Exposure to absolute-maximum-rated conditions for extended periods may affect device reliability.

- NOTES: 1. All voltage values, except differential voltages, are with respect to the network ground.  
 2. Differential voltages are at IN+ with respect to IN-.  
 3. Short circuits from outputs to  $V_{CC}$  can cause excessive heating and eventual destruction.

**DISSIPATION RATING TABLE**

PACKAGE	$T_A \leq 25^\circ\text{C}$ POWER RATING	DERATING FACTOR	DERATE ABOVE $T_A$	$T_A = 70^\circ\text{C}$ POWER RATING	$T_A = 85^\circ\text{C}$ POWER RATING	$T_A = 125^\circ\text{C}$ POWER RATING
D	725 mW	5.8 mW/°C	25°C	464 mW	377 mW	145 mW
FK	900 mW	11.0 mW/°C	68°C	880 mW	715 mW	275 mW
JG	900 mW	8.4 mW/°C	43°C	672 mW	546 mW	210 mW
P	900 mW	8.0 mW/°C	37°C	640 mW	520 mW	200 mW
PW	525 mW	4.2 mW/°C	25°C	336 mW	273 mW	N/A



**LM193, LM293, LM293A, LM393  
LM393A, LM393Y, LM2903, LM2903Q  
DUAL DIFFERENTIAL COMPARATORS**

SLCS005D – JUNE 1976 – REVISED JULY 1998

electrical characteristics at specified free-air temperature,  $V_{CC} = 5\text{ V}$  (unless otherwise noted)

PARAMETER	TEST CONDITIONS	$T_A$ †	LM193			LM293 LM393			UNIT	
			MIN	TYP	MAX	MIN	TYP	MAX		
$V_{IO}$ Input offset voltage	$V_{CC} = 5\text{ V to }30\text{ V},$ $V_O = 1.4\text{ V},$ $V_{IC} = V_{IC(min)}$	25°C		2	5		2	5	mV	
		Full range			9		9			
$I_{IO}$ Input offset current	$V_O = 1.4\text{ V}$	25°C		3	25		5	50	nA	
		Full range			100		250			
$I_{IB}$ Input bias current	$V_O = 1.4\text{ V}$	25°C		-25	-100		-25	-250	nA	
		Full range			-300		-400			
$V_{ICR}$ Common-mode input voltage range‡		25°C		0 to $V_{CC}-1.5$		0 to $V_{CC}-1.5$			V	
		Full range		0 to $V_{CC}-2$		0 to $V_{CC}-2$				
$A_{VD}$ Large-signal differential voltage amplification	$V_{CC} = 15\text{ V},$ $V_O = 1.4\text{ V to }11.4\text{ V},$ $R_L \geq 15\text{ k}\Omega\text{ to }V_{CC}$	25°C		50	200		50	200	V/mV	
$I_{OH}$ High-level output current	$V_{OH} = 5\text{ V}, V_{ID} = 1\text{ V}$	25°C		0.1			0.1	50	nA	
	$V_{OH} = 30\text{ V}, V_{ID} = 1\text{ V}$	Full range			1		1		$\mu\text{A}$	
$V_{OL}$ Low-level output voltage	$I_{OL} = 4\text{ mA}, V_{ID} = -1\text{ V}$	25°C		150	400		150	400	mV	
		Full range			700		700			
$I_{OL}$ Low-level output current	$V_{OL} = 1.5\text{ V}, V_{ID} = 1\text{ V}$	25°C		6			6		mA	
$I_{CC}$ Supply current	$R_L = \infty$	$V_{CC} = 5\text{ V}$	25°C		0.8	1		0.8	1	mA
		$V_{CC} = 30\text{ V}$	Full range			2.5		2.5		

† Full range (MIN or MAX) for LM193 is  $-55^\circ\text{C}$  to  $125^\circ\text{C}$ , for LM293 is  $25^\circ\text{C}$  to  $85^\circ\text{C}$ , and for LM393 is  $0^\circ\text{C}$  to  $70^\circ\text{C}$ . All characteristics are measured with zero common-mode input voltage, unless otherwise specified.

‡ The voltage at either input or common-mode should not be allowed to go negative by more than 0.3 V. The upper end of the common-mode voltage range is  $V_{CC+} - 1.5\text{ V}$ , but either or both inputs can go to 30 V without damage.



**LM193, LM293, LM293A, LM393**  
**LM393A, LM393Y, LM2903, LM2903Q**  
**DUAL DIFFERENTIAL COMPARATORS**

SLCS005D – JUNE 1976 – REVISED JULY 1998

**electrical characteristics at specified free-air temperature,  $V_{CC} = 5\text{ V}$  (unless otherwise noted)**

PARAMETER	TEST CONDITIONS	$T_A$ †	LM293A LM393A			LM2903 LM2903Q			UNIT	
			MIN	TYP	MAX	MIN	TYP	MAX		
$V_{IO}$ Input offset voltage	$V_{CC} = 5\text{ V to }30\text{ V}$ , $V_O = 1.4\text{ V}$ , $V_{IC} = V_{IC(min)}$	25°C		1	3		2	7	mV	
		Full range			4			15		
$I_{IO}$ Input offset current	$V_O = 1.4\text{ V}$	25°C		5	50		5	50	nA	
		Full range			150			200		
$I_{IB}$ Input bias current	$V_O = 1.4\text{ V}$	25°C		-25	-250		-25	-250	nA	
		Full range			-400			-500		
$V_{ICR}$ Common-mode input voltage range‡		25°C		0 to $V_{CC}-1.5$			0 to $V_{CC}-1.5$		V	
		Full range		0 to $V_{CC}-2$			0 to $V_{CC}-2$			
$A_{VD}$ Large-signal differential voltage amplification	$V_{CC} = 15\text{ V}$ , $V_O = 1.4\text{ V to }11.4\text{ V}$ , $R_L \geq 15\text{ k}\Omega\text{ to }V_{CC}$	25°C		50	200		25	100	V/mV	
$I_{OH}$ High-level output current	$V_{OH} = 5\text{ V}$ , $V_{ID} = 1\text{ V}$	25°C		0.1	50		0.1	50	nA	
	$V_{OH} = 30\text{ V}$ , $V_{ID} = 1\text{ V}$	Full range			1			1	$\mu\text{A}$	
$V_{OL}$ Low-level output voltage	$I_{OL} = 4\text{ mA}$ , $V_{ID} = -1\text{ V}$	25°C		150	400		150	400	mV	
		Full range			700			700		
$I_{OL}$ Low-level output current	$V_{OL} = 1.5\text{ V}$ , $V_{ID} = 1\text{ V}$	25°C		6			6		mA	
$I_{CC}$ Supply current	$R_L = \infty$	$V_{CC} = 5\text{ V}$	25°C		0.8	1		0.8	1	mA
		$V_{CC} = 30\text{ V}$	Full range			2.5			2.5	

† Full range (MIN or MAX) for LM293A is 25°C to 85°C, for LM393A is 0°C to 70°C, and for LM2903 and LM2903Q is -40°C to 125°C. All characteristics are measured with zero common-mode input voltage, unless otherwise specified.

‡ The voltage at either input or common-mode should not be allowed to go negative by more than 0.3 V. The upper end of the common-mode voltage range is  $V_{CC+} - 1.5\text{ V}$ , but either or both inputs can go to 30 V without damage.

**electrical characteristics at  $V_{CC} = 5\text{ V}$ ,  $T_A = 25^\circ\text{C}$  (unless otherwise noted)**

PARAMETER	TEST CONDITIONS	LM393Y			UNIT
		MIN	TYP§	MAX	
$V_{IO}$ Input offset voltage	$V_{CC} = 5\text{ V to }30\text{ V}$ , $V_{IC} = V_{ICR(min)}$ , $V_O = 1.4\text{ V}$		2	5	mV
$I_{IO}$ Input offset current			5	50	nA
$I_{IB}$ Input bias current			-25	-250	nA
$V_{ICR}$ Common-mode input voltage range	$V_{CC} = 5\text{ V to }30\text{ V}$		0 to $V_{CC}-1.5$		V
$A_{VD}$ Large-signal differential voltage amplification	$V_{CC} = 15\text{ V}$ , $R_L \geq 15\text{ k}\Omega\text{ to }V_{CC}$ , $V_O = 1.4\text{ V to }11.4\text{ V}$		25	200	V/mV
$I_{OH}$ High-level output current	$V_{OH} = 5\text{ V}$ , $V_{ID} = 1\text{ V}$		0.1	50	nA
$V_{OL}$ Low-level output voltage	$I_{OL} = 4\text{ mA}$ , $V_{ID} = -1\text{ V}$		150	400	mV
$I_{OL}$ Low-level output current	$V_{OL} = 1.5\text{ V}$ , $V_{ID} = -1\text{ V}$		6		mA
$I_{CC}$ Supply current	$R_L = \infty$ , $V_{CC} = 5\text{ V}$		0.8	1	mA

§ All characteristics are measured under open-loop conditions with zero common-mode input voltage, unless otherwise specified.



**LM193, LM293, LM293A, LM393  
LM393A, LM393Y, LM2903, LM2903Q  
DUAL DIFFERENTIAL COMPARATORS**

SLCS005D – JUNE 1976 – REVISED JULY 1998

switching characteristics,  $V_{CC} = 5\text{ V}$ ,  $T_A = 25^\circ\text{C}$

PARAMETER	TEST CONDITIONS		LM193 LM293, LM293A LM393, LM393A LM2903, LM2903Q			UNIT
			MIN	TYP	MAX	
Response time	$R_L$ connected to 5 V through 5.1 k $\Omega$ , $C_L = 15\text{ pF}$ †, See Note 4	100-mV input step with 5-mV overdrive		1.3		$\mu\text{s}$
		TTL-level input step		0.3		

†  $C_L$  includes probe and jig capacitance.

NOTE 4: The response time specified is the interval between the input step function and the instant when the output crosses 1.4 V.

