

# PGT 5220

## Optical Transmitter Module

### for STM-1 SH/OC-3 IR

The transmitter module is intended for use at SDH and SONET bit rates. The device meet all present requirements in the ITU-T (G.957, G.958) and Bellcore (GR-253-CORE) recommendations.

The single silicon IC is used as a laser-driver, modulator with data re-shape and automatic power control. To ensure a proper laser operation over the wide temperature range and life of operation both the peak and average optical output power are controlled. The laser bias is externally accessible for monitoring of the performance. A power alarm is activated when the average optical power or the extinction ratio cannot be maintained within specification.

A laser power down function is also provided according to SDH/SONET requirements.

Ericsson Components fiber optic products are qualified to Ericsson internal standards which use MIL-STD-883 test methods.

#### Features

- Low power consumption
- Peak and average power control
- Single +5.0 V supply
- Small size (30x50x9 mm<sup>3</sup>)
- CMOS alarm output
- Clocked or non-clocked re-shape

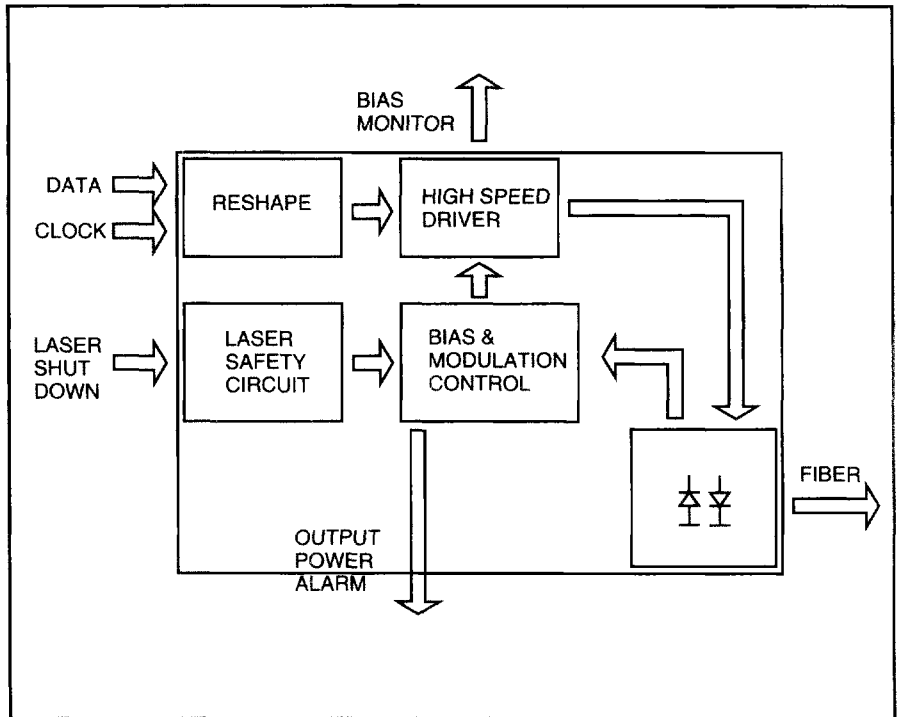

#### Pin connection

- |                               |                   |          |
|-------------------------------|-------------------|----------|
| 1. NC                         | 19. Clock disable | 24. Data |
| 2. Laser shut down            | 20. Clock_N       | 25. VECL |
| 3. VCC                        | 21. Clock         | 26. NC   |
| 4. Laser bias current monitor | 22. GND           | 27. VCC  |
| 5. NC                         | 23. Data_N        | 28. GND  |

#### Bottom view

- NC
- NC
- Laser control circ. out of range
- NC
- NC
- NC
- NC
- NC
- NC
- NC
- NC
- NC
- NC
- NC
- NC
- GND
- GND

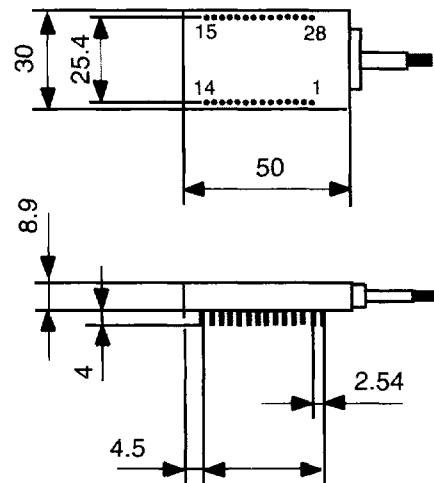

## Optical and Electrical Specification

Item	PGT 5220	Unit
Bit rate	155.52	Mbit/s
Average output power	-15 to -8	dBm
Peak wavelength	1261 - 1360	nm
Spectral width (RMS)	max 7.7	nm
Extinction ratio	min 8.2	dB
Output signal jitter	max 0.01	UI rms
Eye diagram	G. 957	ITU-T
Power consumption	max. 0.5	W
Power supply	+5.0 ± 0.3	V
Operating case temperature	-40 to +85	°C

## Electrical Interface

Input signals	ECL or P-ECL (10 K or 100 K) AC coupled with 50 ohm termination.
Laser shut down	CMOS (max 200 ms delay/wake up time), active high.
Laser bias monitor	Analogue voltage between 0 and +5 V (40 mV/mA).
Laser control circuitry out of range	CMOS, active high when the laser control circuitry is out of range and no longer can maintain output power or extinction ratio within specification.

## Quality Assurance

Ericsson Components commitment to quality has been proved through a decade of semiconductor device production and has been confirmed to ISO 9001. These products are qualified according to the intention of Bellcore (TR-NWT-000468) and supplied with final test data.

## Connector Options

FC/PC

SC

(Other connector available on request)

Ericsson Components  
 Phone: +46 (8) 757 4402  
 Fax: +46 (8) 757 4621  
**American Sales Region**  
 Phone: +1 (972) 583 7236  
 Fax: +1 (972) 583 5005  
**European Sales Region**  
 Phone: +44 (1793) 488 300  
 Fax: +44 (1793) 488 301

Information given in this data sheet is believed to be accurate and reliable. However no responsibility is assumed for the consequences of its use nor for any infringement of patents or other rights of third parties which may result from its use. No license is granted by implication or otherwise under any patent or patent rights of Ericsson Components AB. These products are sold only according to Ericsson Components general conditions of sale, unless otherwise confirmed in writing.

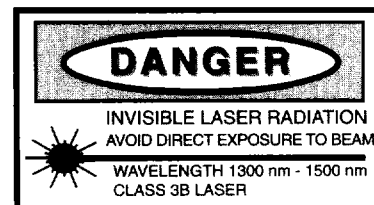

Specifications subject to change without notice.  
 1522-PGT 5220 Uen Rev. A  
 © Ericsson Components AB, April 3, 1997