

High Precision TCXO / VCTCXO

CONNOR WINFIELD



2111 Comprehensive Drive
Aurora, Illinois 60505
Phone: 630-851-4722
Fax: 630-851-5040
www.conwin.com

Description:

The Connor-Winfield 9x14mm Temperature Compensated Crystal Controlled Oscillators (TCXO series) and Voltage Controlled Temperature Compensated Crystal Controlled Oscillators (VCTCXO series) are designed for use in Telecom applications requiring tight frequency stability. Through the use of Analog Temperature Compensation, this device is capable of holding sub 1-ppm stabilities over the commercial or the industrial temperature ranges.



Features:

- TCXO or VCTCXO
- 3.3 Vdc or 5.0 Vdc Operation
- LVC MOS or HCMOS Output Logic
- 9x14mm Surface Mount Package
- Frequency Stabilities Available:
 - ±0.25 ppm, ±0.28 ppm ±0.5 ppm, ±1.0 ppm
- Temperature Ranges Available:
 - 0 to 70°C or -40 to 85°C
- RoHS Compliant / Lead Free
- Low Jitter <1 ps RMS
- Tri-State Enable/Disable Function
- Tape and Reel Packaging

Operating Specifications

Parameter	Minimum	Nominal	Maximum	Units	Notes
Frequency Range: (Fo) (See ordering information below.)					
Stability Code C	6.4	-	32	MHz	
Stability Code D	6.4	-	40	MHz	
Stability Code E	6.4	-	52	MHz	
Stability Code F	6.4	-	100	MHz	
Frequency Stability vs. Temperature: {±(Fmax - Fmin)/2 Fo} (See ordering information on page 2.)					
Stability Code C	-0.25	-	0.25	ppm	
Stability Code D	-0.28	-	0.28	ppm	
Including Holdover	-0.32	-	0.32	ppm	1
Stability Code E	-0.50	-	0.50	ppm	
Stability Code F	-1.00	-	1.00	ppm	
Frequency Calibration (@25°C)	-1.00	-	1.00	ppm	2
Frequency Stability vs. Voltage	-0.20	-	0.20	ppm	±5%
Frequency Stability vs. Load	-0.20	-	0.20	ppm	±5%
Static Temperature Hysteresis	-0.40	-	0.40	ppm	3
Aging: First Year	-1.0	-	1.0	ppm	
Total Frequency Tolerance	-4.6	-	4.6	ppm	4
Operating Temperature Range: (See ordering information below.)					
Temperature Code 5	0	-	70	°C	
Temperature Code 6	-40	-	85	°C	
Supply Voltage: (Vcc) (See ordering information below.)					
Voltage Code L	3.135	3.30	3.465	Vdc	±5%
Voltage Code H	4.75	5.00	5.25	Vdc	±5%
Supply Current	-	6	15	mA	
Start-up Time	-	-	10	ms	

Notes:

1. Holdover includes frequency stability (±0.28 ppm), supply voltage change(±5%) and aging for 24 hours.
2. TCXO: Initial calibration @ 25°C. Specification at time of shipment after 48 hours of operation.
3. Frequency change after reciprocal temperature ramped over the operating range. Frequency measured before and after at 25°C.
4. Inclusive of calibration @ 25°C, frequency vs. change in temperature, change in supply voltage (±5%), load change (±5%), reflow soldering process and 10 years aging

Package Outline

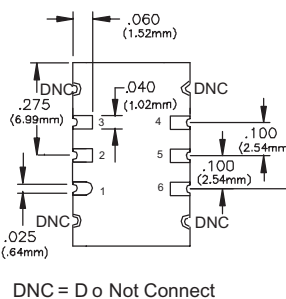
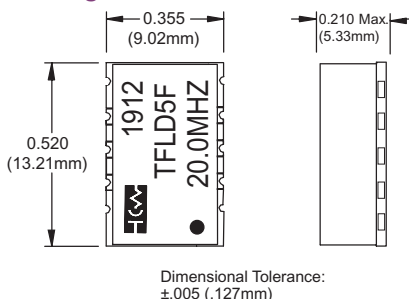

Suggested Pad Layout

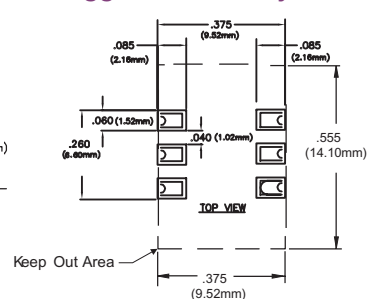



Absolute Maximum Ratings

Parameter	Minimum	Nominal	Maximum	Units	Notes
Storage Temperature	-55	-	85	°C	
Supply Voltage (Vcc)	-0.5	-	6.0	Vdc	
Input Voltage	-0.5	-	Vcc+0.6	Vdc	

Input Characteristics for Enable / Disable Function

Parameter	Minimum	Nominal	Maximum	Units	Notes
Enable Voltage (High) (Vih)	70%Vcc	-	-	Vdc	5
Disable Voltage (Low) (Vil)	-	-	30%Vcc	Vdc	5

VCTCXO Input Characteristics for Voltage Control Function

Parameter	Minimum	Nominal	Maximum	Units	Notes
Control Voltage (Vcc = 3.3 Vdc)	0.3	1.65	3.0	Vdc	
Control Voltage (Vcc = 5.0 Vdc)	0.5	2.5	4.5	Vdc	
Frequency Tuning measured @ 25°	±10	-	-	ppm	Positive Slope
Input Impedance	±100K	-	-	Ohm	
Linearity	±5	-	-	%	

CMOS Output Characteristics

Parameter	Minimum	Nominal	Maximum	Units	Notes
Load	-	15	-	pF	
Voltage (High) Voh	90%Vcc	-	-	V	
(Low) Vol	-	-	10%Vcc	V	
Duty Cycle at 50% Vcc	45	50	55	%	
Rise / Fall Time 10% to 90%	-	5	8	ns	
Phase Jitter (BW=12KHz to Fo/2)	-	-	1	ps RMS	
Period Jitter	-	-	3	ps RMS	
Typical SSB Phase Noise					
For Fo	10.0 MHz	50.0 MHz	100.0 MHz		
@ 10 Hz offset	-98	-70	-60	dBc/Hz	
@ 100 Hz offset	-125	-100	-91	dBc/Hz	
@ 1 KHz offset	-143	-122	-119	dBc/Hz	
@ 10 KHz offset	-151	-145	-142	dBc/Hz	
@ 100 KHz offset	-152	-150	-153	dBc/Hz	
@ 1 MHz offset	-155	-152	-153	dBc/Hz	

Notes:

5. Oscillator output is enabled with no connection on pin 2. Output is at high impedance when disabled.

Ordering Information

TF	L	D	5	C	- 010.0M
Type TF = TCXO TV = VCTCXO CMOS Output	Supply Voltage L = 3.3 Vdc H = 5.0 Vdc	Package Size D = 9 x 14 mm Surface Mount Package	Temperature Range 5 = 0 to 70°C 6 = -40 to 85°C	Frequency Stability C = ±0.25ppm D = ±0.28ppm E = ±0.50ppm F = ±1.00ppm	Output Frequency Frequency Format * -xxx.xM Min. -xxx.xxxxx Max. *Min 1 and Max 6 digits after the decimal point. Always 3 digits before the decimal point

Example Part Number:

TFLD5C-010.0M = TCXO, 3.3 Vdc, 9x14mm package, 0 to 70°C temperature range, ±0.25ppm frequency stability, output frequency 10.0 Mhz.
To order a TFLD5C with an output frequency of: 6.4 MHz = TFLD5C-006.4M, 16.384 MHz = TFLD5C-016.384M.

Package Characteristics

Package FR4 substrate, surface mount package

Environmental Characteristics

Vibration: Vibration per Mil Std 883E Method 2007.3 Test Condition A
Shock: Mechanical Shock per Mil Std 883E Method 2002.4 Test Condition B.
Soldering Process: RoHS compliant lead free. See soldering profile below.
Solderability: Solderability per Mil Std 883E Method 2003

Test Circuit

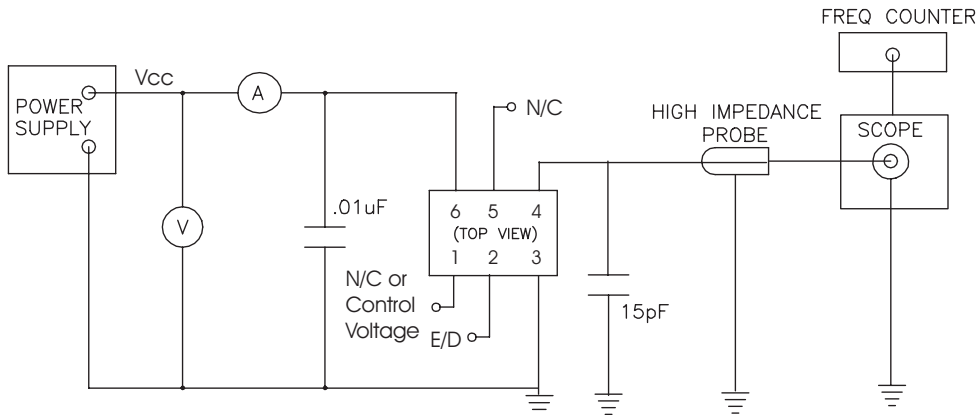

Pad Connections

Pad Connection
1: N/C or Control Voltage
2: Enable / Disable
3: Ground (Case)
4: Output
5: N/C
6: Supply Voltage (Vcc)

Output Waveform

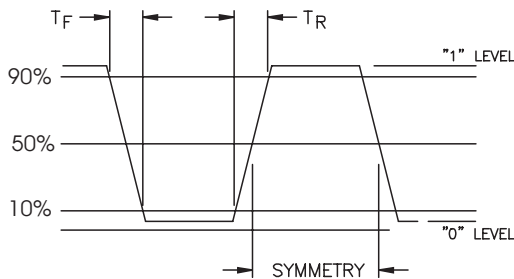

Solder Profile

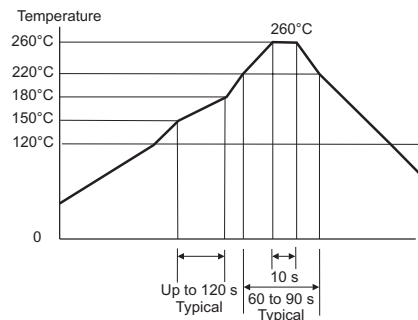

Meets IPC/JEDEC J-STD-020C

Tape and Reel Information

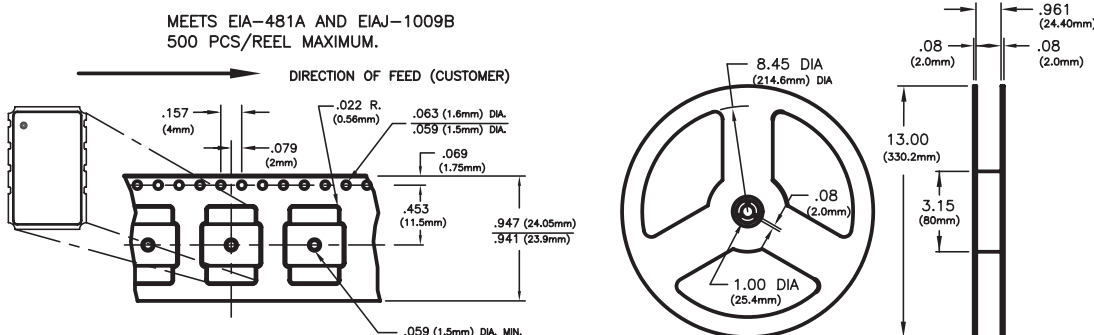

Bulletin **Tx134**
Page **3 of 3**
Revision **07**
Date **01 April 2019**