

# M-957-02 DTMF Receiver

- Complete DTMF receiver in 22-pin plastic package
- Decodes all 16 DTMF digits
- Excellent dial tone and speech immunity
- Meets telephone impulse noise immunity standards
- Digitally selectable sensitivity to -38 dBm
- Selectable 4-bit hexadecimal or binary coded 2 of 8 output
- Fabricated using low-power CMOS technology
- Operates on single DC supply
- Uses inexpensive 3.58-MHz crystal
- Three-state outputs
- 5-Volt supply
- Applications include: central office products, PBX and key systems, radio telephones, remote control and monitoring devices, computer data entry systems

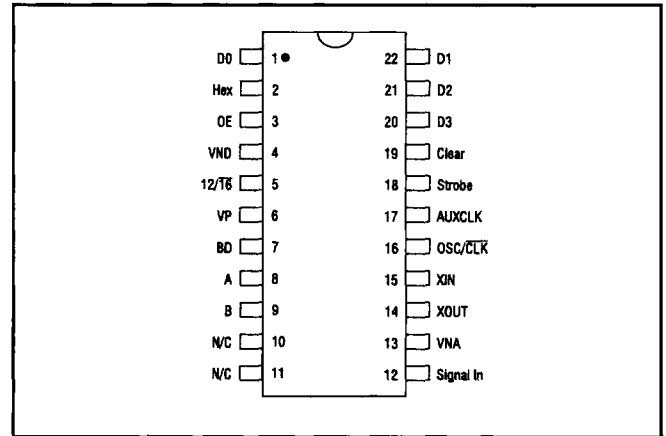

Figure 1 Pin Diagram

The M-957 (see Figure 1) combines switched-capacitor and digital frequency measuring techniques to decode Dual-Tone Multifrequency (DTMF) signals to four-bit binary data. Dial tone rejection and 60-Hz noise rejection filters are built in. Fabricated as a monolithic integrated circuit using low-power CMOS processing, the M-957 is packaged in a 22-pin DIP. The M-957-02 operates from a 5-Volt supply. An inexpensive 3.58-MHz television crystal and resistor are the only external components required. High system density may be achieved by using the clock output of one crystal-connected receiver to drive the time bases of additional receivers.

other DTMF signal sources. Inputs A and B control sensitivity to a maximum of -38 dBm at 5 V, while the 12/16 input determines the signals to be detected. The preprocessing stages of the M-957 filter out dial tone and noise, split the signal into its high- and low-frequency components, and hard-limit each component to provide automatic gain control. Four discriminators in each group then detect the individual tones. Postprocessing stages of the M-957 time the tone durations and store binary data for outputting as determined by the HEX input. The STROBE output is activated by the presence of valid data in the output register and cleared by the detection of a valid end-of-signal pause or by the CLEAR input. An early signal presence indicator, BD, facilitates applications requiring tone blocking. The data outputs operate with simple logic circuits or

The SIGNAL IN input to the M-957 (see Figure 2) interfaces readily to telephone lines, radio receivers, tape players, and

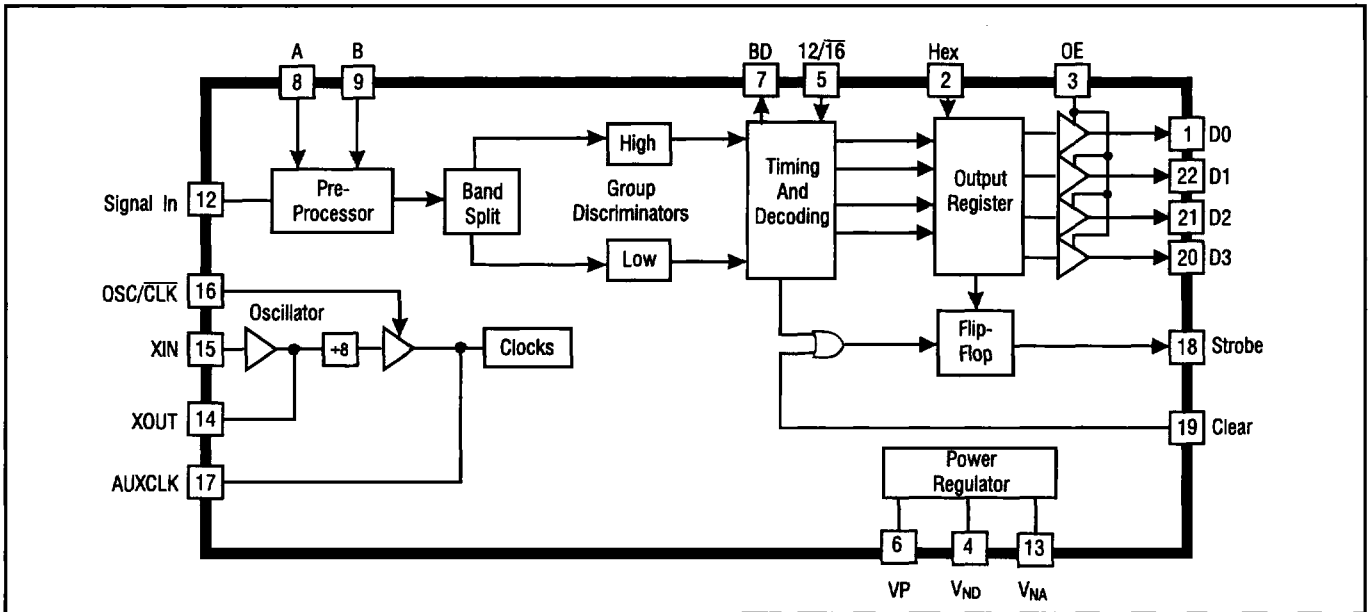

Figure 2 Block Diagram

microprocessors, and are Tri-state enabled to facilitate bus-oriented architectures.

**Ordering Information**

M-957-02P

5 Volt, 22-pin plastic DIP

**Table 1 Pin Functions**

Pin	Function
SIGNAL IN	DTMF input. Timings are shown in Figure 3. Internally biased so that the input signal may be AC coupled, SIGNAL IN also permits DC coupling as long as the input voltage does not exceed the positive supply. Proper coupling is shown in Figure 8. See Table 2 for the frequency pairs associated with each DTMF signal.
12/16	DTMF signal detection control. When 12/16 is at logic "1", the M-957 detects the 12 most commonly used DTMF signals (1 through #). When 12/16 is at logic "0", the M-957 detects all 16 DTMF signals (1 through D).
A, B (See Table 4)	Binary DTMF signal sensitivity control inputs. A and B select the sensitivity of the SIGNAL IN input to a maximum of -38 dBm.
D3, D2, D1, D0	Data outputs. When enabled by the OE input, the data outputs provide the code corresponding to the detected digit in the format programmed by the HEX pin. See Table 2. The data outputs become valid after a tone pair has been detected and are cleared when a valid pause is timed. Timings are shown in Figure 3.
OE	Output enable. When OE is at logic "1", the data outputs are in the CMOS push/pull state and represent the contents of the output register (see Figure 2). When OE is driven to logic "0", the data outputs are forced to the high-impedance or "third" state. Timings are shown in Figure 3.
HEX	Binary output format control. When HEX is at logic "1", the output of the M-957 is full, 4-bit binary. When HEX is at logic "0", the output is binary coded 2-of-8. Table 2 shows the output code.
STROBE	Valid data indication. STROBE goes to logic "1" after a valid tone pair is sensed and decoded at the data outputs. STROBE remains at logic "1" until a valid pause occurs or the CLEAR input is driven to logic "1", whichever is earlier. Timings are shown in Figure 3.
CLEAR	STROBE control. Driving CLEAR to logic "1" forces the STROBE output to logic "0". When CLEAR is at logic "0", STROBE is forced to logic "0" only when a valid pause is detected. Tie to VNA or VND when not used.
BD	Early signal presence output. BD indicates that a possible signal has been detected and is being validated. As shown in Figure 3, BD precedes STROBE and the data outputs.
XIN, XOUT	Crystal connections. When an auxiliary clock is used, XIN should be tied to logic "1". See Figure 5.
OSC/CLK	Time base control. When OSC/CLK is at logic "1", the output of the M-957's internal oscillator is selected as the time base. When OSC/CLK is at logic "0" and XIN is at logic "1", the AUXCLK input is selected as the time base.
AUXCLK	Auxiliary clock input. When OSC/CLK is at logic "0" and XIN is at logic "1", the AUXCLK input is selected as the M-957's time base. The auxiliary input must be 3.58 MHz divided by 8 for the M-957 to operate to specifications. If unused, AUXCLK should be left open.
VNA, VND	Negative analog and digital power supply connections. Separated on the chip for greater system flexibility, VNA and VND should be at equal potential.
VP	Positive power supply connection.
N/C	Not connected. These pins have no internal connection and may be left floating.

**Table 2 DTMF to Binary Decoding**

DTMF Digit	Low-Frequency Component (Hz)	High-Frequency Component (Hz)	Hex Output Format D3 D2 D1 D0	2-OF-8 Output Format D3 D2 D1 D0
1	697	1209	0 0 0 1	0 0 0 0
2	697	1336	0 0 1 0	0 0 0 1
3	697	1477	0 0 1 1	0 0 1 0
4	770	1209	0 1 0 0	0 1 0 0
5	770	1336	0 1 0 1	0 1 0 1
6	770	1477	0 1 1 0	0 1 1 0
7	852	1209	0 1 1 1	1 0 0 0
8	852	1336	1 0 0 0	1 0 0 1
9	852	1477	1 0 0 1	1 0 1 0
0	941	1336	1 0 1 0	1 1 0 1
*	941	1209	1 0 1 1	1 1 0 0
#	941	1477	1 1 0 0	1 1 1 0
A	697	1633	1 1 0 1	0 0 1 1
B	770	1633	1 1 1 0	0 1 1 1
C	852	1633	1 1 1 1	1 0 1 1
D	941	1633	0 0 0 0	1 1 1 1

**Table 3 Absolute Maximum Ratings (Note 1)**

M-957-02 DC Supply Voltage (Note 2)	7.0V
Voltage on SIGNAL IN	(V <sub>P</sub> +0.5V) to (V <sub>P</sub> - 22 V)
Voltage on Any Pin Except SIGNAL IN	(V <sub>P</sub> + 0.5V) to (V <sub>ND</sub> - 0.5 V)
Storage Temperature Range	-65° to 150°C
Operating Temperature Range	-0° to 70°C
Lead Soldering Temperature	260°C for 5 seconds
Power Dissipation	1W

**Notes:**

1. Exceeding these ratings may permanently damage the M-957.
2. V<sub>P</sub> referenced to V<sub>ND</sub>. V<sub>ND</sub> should be at equal potential to V<sub>NA</sub>. V<sub>ND</sub>/V<sub>NA</sub> may be at ground.

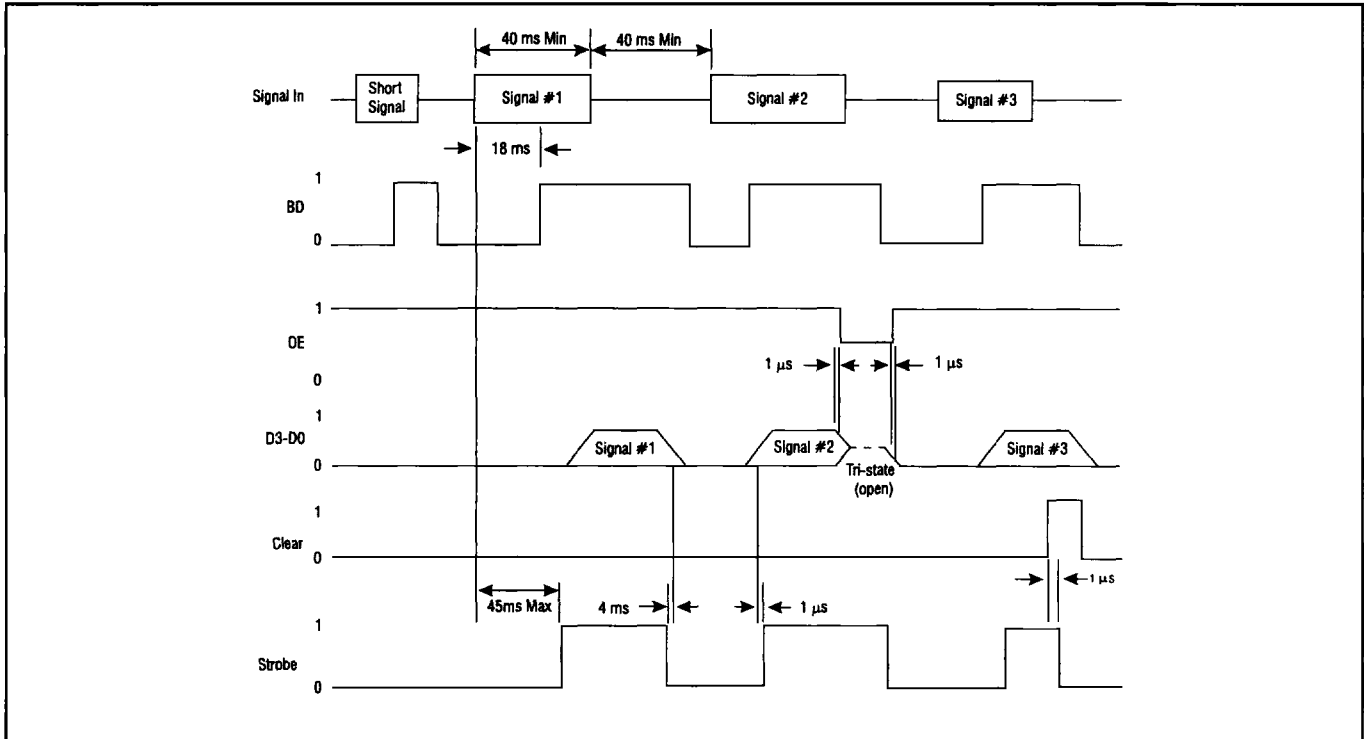

**Figure 3 Timing Diagram**

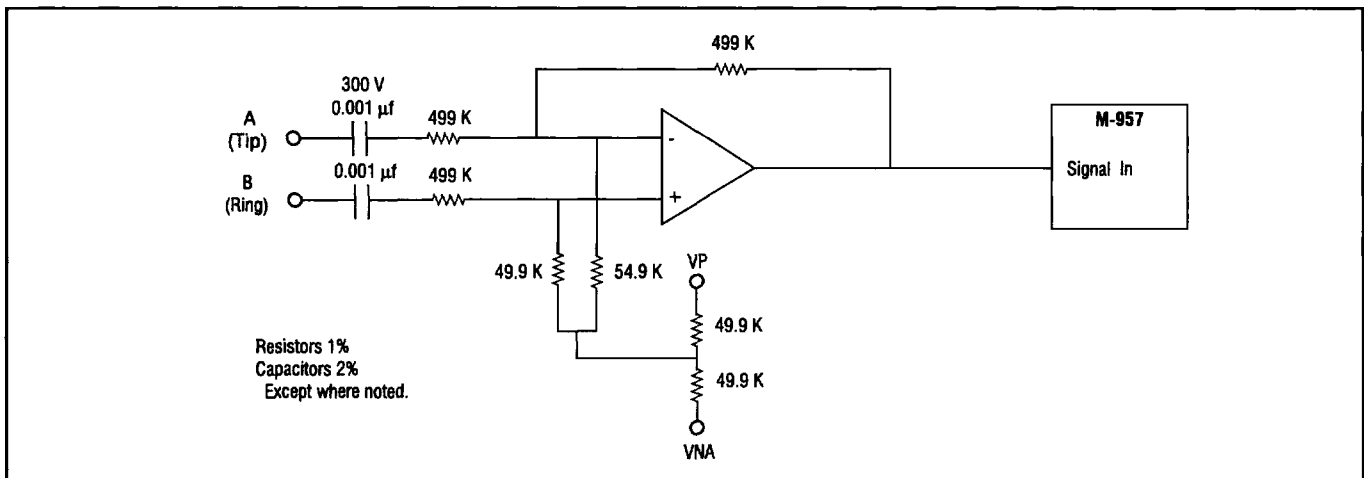

**Figure 4 Telephone Line Differential Input Interface**

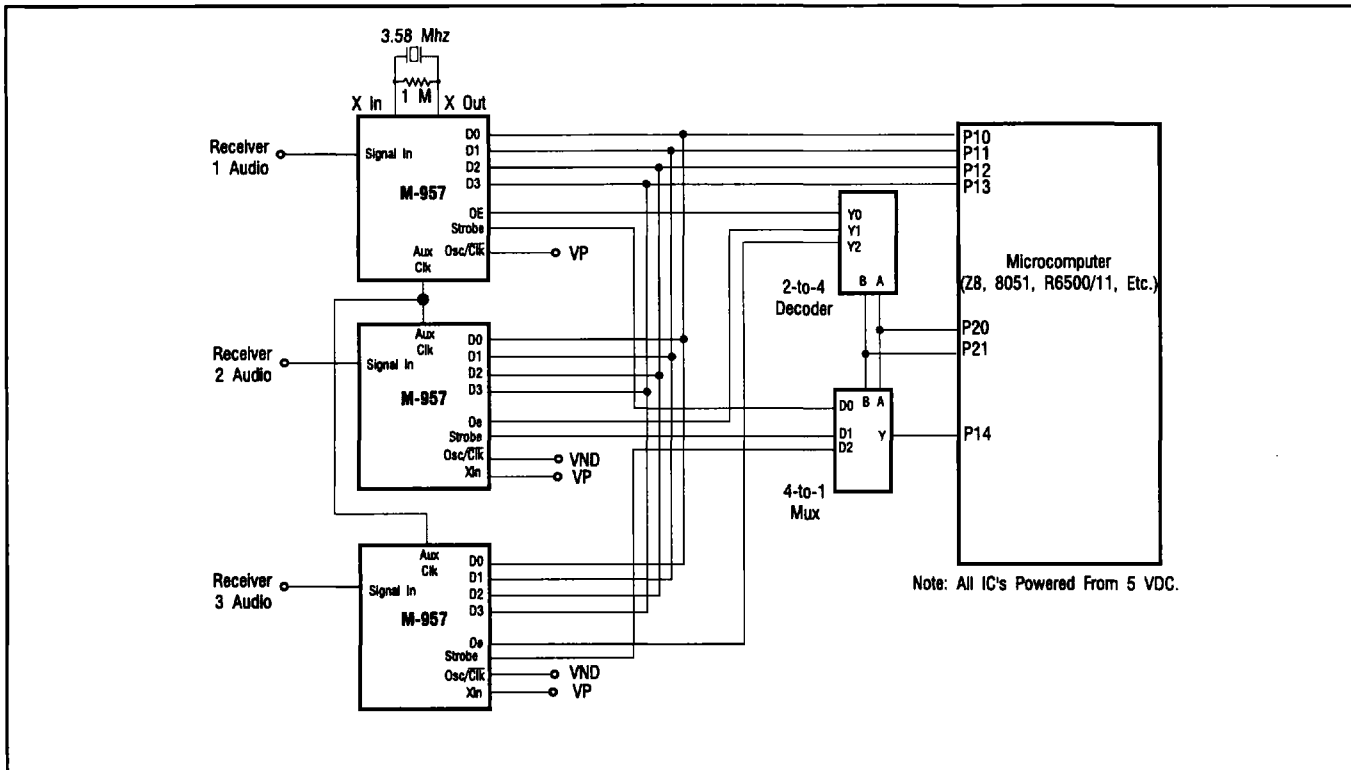

Figure 5 Multiple Receiver/Microprocessor Interface

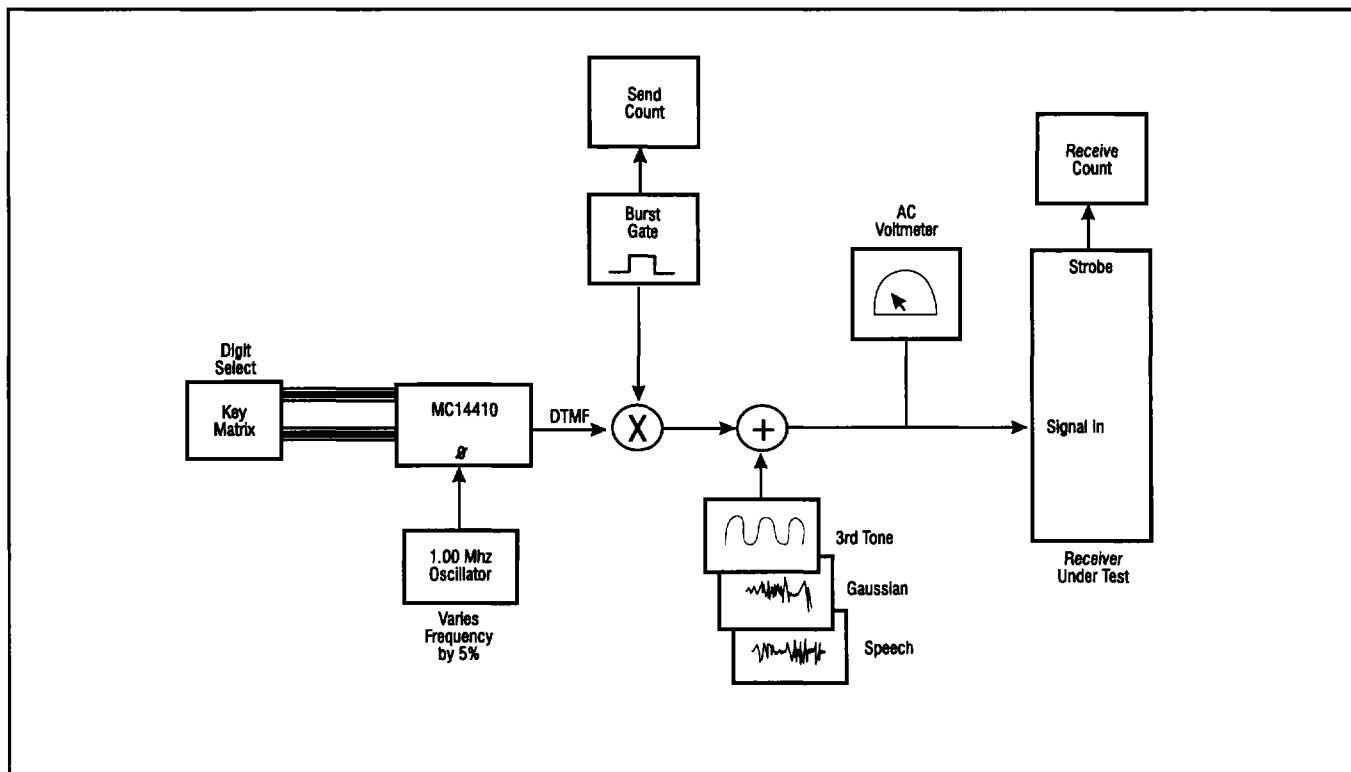

Figure 6 Test Circuit

Table 4 Specifications

		Notions	Min	Typ	Max	Units	Notes
SIGNAL IN Input Requirements	Signal Level (per tone)	$V_P = 5V$	-	-	-		
		A = 0, B = 0	-32	-	-2	dBm	1
		A = 1, B = 0	-35	-	-5	dBm	1
		A = 0, B = 1	-38	-	-8	dBm	1
		A = 1, B = 1	-	-40	-	dBm	1
	Signal Duration	-	40	-	-	ms	
	Interval Between Signals	-	40	-	-	ms	
	Signal Present Without Detection	-	-	-	20	ms	
	Interruption of Signal Without Reduction	-	-	-	20	ms	
	Signal Frequency Deviation With Detection	-	-(1.5% +2)	-	+(1.5% + 2)	Hz	
	Signal Frequency Deviation Without Detection	-	-3.5%	-	+3.5	Hz	
	Twist	-	-10	-	+10	dB	2
Gaussian Noise	-	12	-	A - 7	dB	3	
Dial Tone Level (per tone, $F \leq 480$ Hz)	-	-	-	A + 22	dB	4	
Digital Input Characteristics	Logic 0 Voltage	$V_P = 5V$	0	-	1.5	V	5
	Logic 1 Voltage	$V_P = 5V$	3.5	-	5.0	V	5
Digital Output Characteristics	Logic 0 Voltage	$V_P = 5V, I_O = 0.4$ mA	0	-	0.5	V	5
	Logic 1 Voltage	$V_P = 5V, I_O = -0.2$ mA	4.5	-	5.0	V	5
	Tri-State Leakage	-	-	-	1.0	mA	
Miscellaneous Characteristics	CMOS Latch-up Voltage	--	20	-	-	V	6
	SIGNAL IN Input Impedance	F = 1 kHz, paralleled with 15 pF	100	-	-	k $\Omega$	
Power Requirements	Supply Voltage	-	2.5	-	5.5	V	
	Supply Current	$V_P = 5V$	-	6	18	mA	
	Power Dissipation (Outputs Open)	$V_P = 5V$	-	30	90	mW	7
	Power Supply Wide Band Noise (A = 0, B = 0)	-	-	-	10	mVpp	
<b>Notes:</b>							
1. With an ambient temperature of 25°C, the signal duration and signal interval at minimum, and the signal frequency deviation and twist at maximum. The unit "dBm" refers to decibels above or below a reference power of one milliwatt into a 600 $\Omega$ load. (For example, -24dBm = 49 mVrms.)							
2. Twist is defined as the ratio of the level of the high-frequency DTMF component to the level of the low-frequency DTMF component.							
3. With an ambient temperature of 25°C, the signal level at A+5, the signal frequency deviation and twist at 0, and the signal applied 50 ms off and 50 ms on.							
4. With the signal duration and signal interval at minimum, and the signal frequency deviation and twist at maximum. The A level is the minimum detect level selected.							
5. Logic levels shown are referenced to VND.							
6. Power supply excursions above this value can cause device damage.							
7. For an ambient temperature of 25°C.							

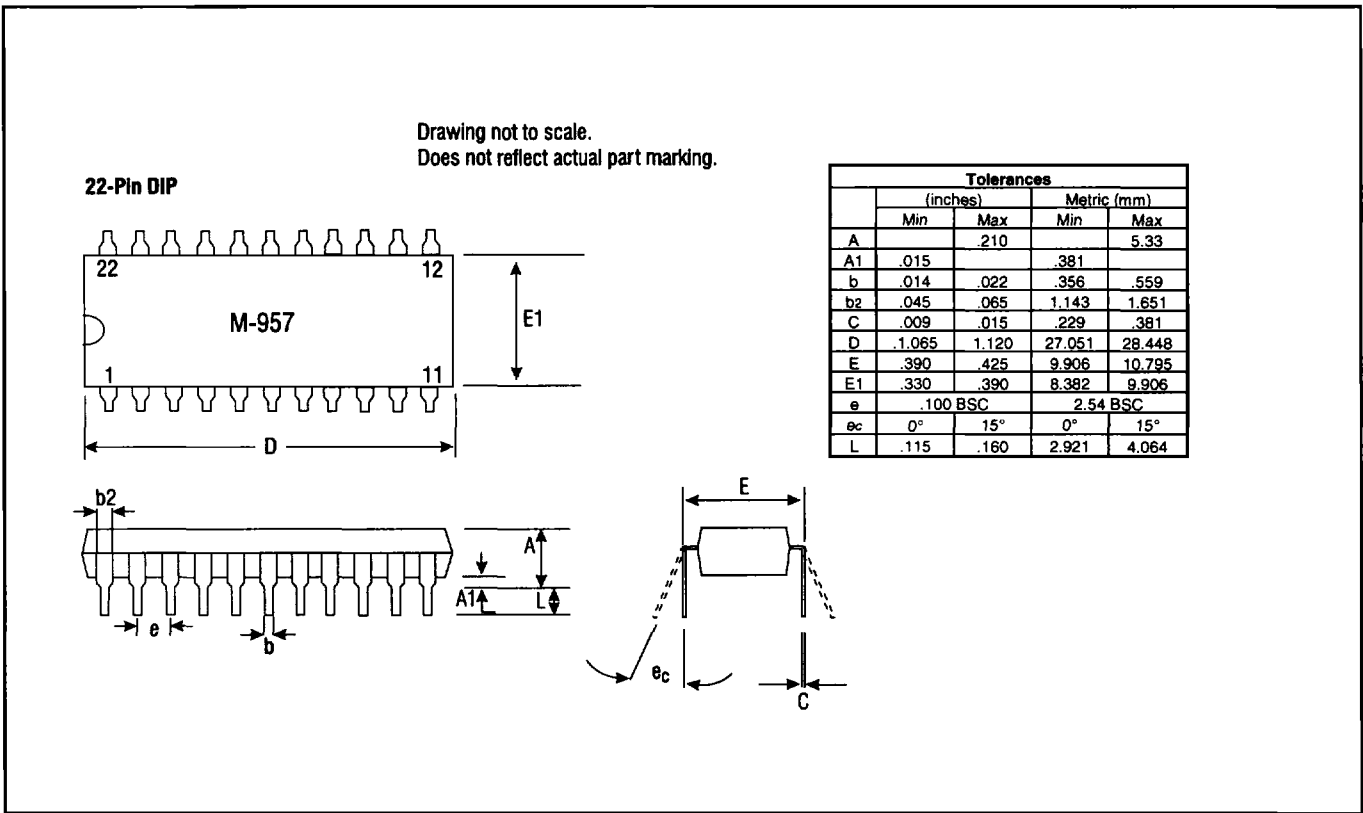

Figure 7 Package Dimensions

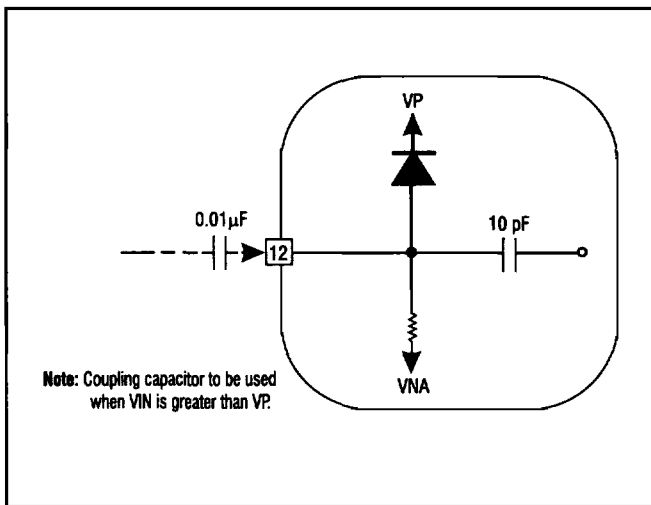

Figure 8 Input Signal Configuration