

SN54132, SN54LS132, SN54S132, SN74132, SN74LS132, SN74S132 QUADRUPLE 2-INPUT POSITIVE-NAND SCHMITT TRIGGERS

DECEMBER 1983 — REVISED MARCH 1988

- Operation from Very Slow Edges
- Improved Line-Receiving Characteristics
- High Noise Immunity

description

Each circuit functions as a 2-input NAND gate, but because of the Schmitt action, it has different input threshold levels for positive (V_{T+}) and for negative going (V_{T-}) signals.

These circuits are temperature-compensated and can be triggered from the slowest of input ramps and still give clear, jitter-free output signals.

The SN54132, SN54LS132, and SN54S132 are characterized for operation over the full military temperature range of -55°C to 125°C . The SN74132, SN74LS132, and SN74S132 are characterized for operation from 0°C to 70°C .

logic diagram (positive logic)

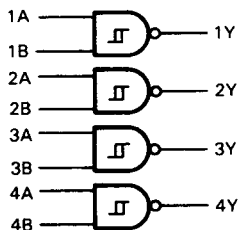

SN54132, SN54LS132, SN54S132 . . . J OR W PACKAGE
SN74132 . . . N PACKAGE
SN74LS132, SN74S132 . . . D OR N PACKAGE

(TOP VIEW)

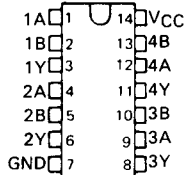

SN54LS132, SN54S132 . . . FK PACKAGE

(TOP VIEW)

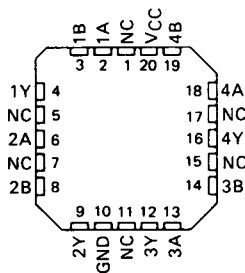

NC—No internal connection

logic symbol†

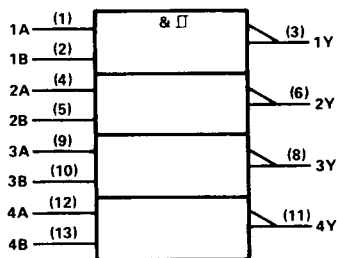

positive logic: $Y = \overline{AB}$ or $Y = \overline{A} + \overline{B}$

† This symbol is in accordance with ANSI/IEEE Std 91-1984 and IEC Publication 617-12.

Pin numbers shown are for D, J, N, and W packages.

2

TTL Devices

**SN54132, SN54LS132, SN54S132,
SN74132, SN74LS132, SN74S132
QUADRUPLE 2-INPUT POSITIVE-NAND SCHMITT TRIGGERS**

schematics

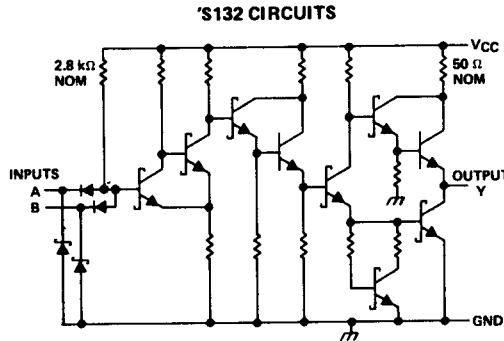
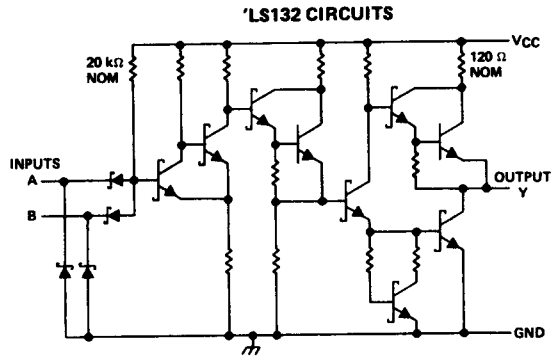
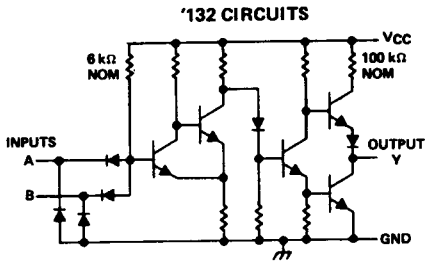

Resistor values shown are nominal.

absolute maximum ratings over operating free-air temperature range (unless otherwise noted)

Supply voltage, V_{CC} (see Note 1)	7 V
Input voltage: '132, 'S132	5.5 V
'LS132	7 V
Operating free-air temperature: SN54'	-55°C to 125°C
SN74'	0°C to 70°C
Storage temperature range	-65°C to 150°C

NOTE 1: Voltages values are with respect to network ground terminal.

2

TTL Devices

SN54132, SN74132 QUADRUPLE 2-INPUT POSITIVE-NAND SCHMITT TRIGGERS

recommended operating conditions

	SN54132			SN74132			UNIT
	MIN	NOM	MAX	MIN	NOM	MAX	
V _{CC} Supply voltage	4.5	5	5.5	4.75	5	5.25	V
I _{OH} High-level output current			-0.8			-0.8	mA
I _{OL} Low-level output current			16			16	mA
T _A Operating free-air temperature	-55		125	0		70	°C

electrical characteristics over recommended operating free-air temperature range (unless otherwise noted)

PARAMETER	TEST CONDITIONS†	MIN	TYP‡	MAX	UNIT
V _{T+}	V _{CC} = 5 V	1.5	1.7	2	V
V _{T-}	V _{CC} = 5 V	0.6	0.9	1.1	V
V _{hys} (V _{T+} - V _{T-})	V _{CC} = 5 V	0.4	0.8		V
V _{IK}	V _{CC} = MIN, I _I = -12 mA			-1.5	V
V _{OH}	V _{CC} = MIN, V _I = 0.6 V, I _{OH} = -0.8 mA	2.4	3.4		V
V _{OL}	V _{CC} = MIN, V _I = 2 V, I _{OL} = 16 mA		0.2	0.4	V
I _{T+}	V _{CC} = 5 V, V _I = V _{T+}		-0.43		mA
I _{T-}	V _{CC} = 5 V, V _I = V _{T-}		-0.56		mA
I _I	V _{CC} = MAX, V _I = 5.5 V			1	mA
I _{IH}	V _{CC} = MAX, V _I = 2.4 V			40	μA
I _{IL}	V _{CC} = MAX, V _{IL} = 0.4 V		-0.8	-1.2	mA
I _{OS} §	V _{CC} = MAX	-18		-55	mA
I _{CCH}	V _{CC} = MAX		15	24	mA
I _{CCL}	V _{CC} = MAX		26	40	mA

† For conditions shown as MIN or MAX, use the appropriate value specified under recommended operating conditions.

‡ All typical values are at V_{CC} = 5 V, T_A = 25°C.

§ Not more than one output should be shorted at a time.

switching characteristics, V_{CC} = 5 V, T_A = 25°C (see figure 1)

PARAMETER	FROM (INPUT)	TO (OUTPUT)	TEST CONDITIONS	MIN	TYP	MAX	UNIT
t _{PLH}	Any	Y	R _L = 400 Ω, C _L = 15 pF		15	22	ns
t _{PHL}					15	22	ns

2

TTL Devices

SN54LS132, SN74LS132 QUADRUPLE 2-INPUT POSITIVE-NAND SCHMITT TRIGGERS

recommended operating conditions

	SN54LS132			SN74LS132			UNIT
	MIN	NOM	MAX	MIN	NOM	MAX	
V _{CC} Supply voltage	4.5	5	5.5	4.75	5	5.25	V
I _{OH} High-level output current			-0.4			-0.4	mA
I _{OL} Low-level output current			4			8	mA
T _A Operating free-air temperature	-55		125	0		70	°C

electrical characteristics over recommended operating free-air temperature range (unless otherwise noted)

PARAMETER	TEST CONDITIONS†	SN54LS132			SN74LS132			UNIT
		MIN	TYP‡	MAX	MIN	TYP‡	MAX	
V _{T+}	V _{CC} = 5 V	1.4	1.6	1.9	1.4	1.6	1.9	V
V _{T-}	V _{CC} = 5 V	0.5	0.8	1	0.5	0.8	1	V
V _{hys} (V _{T+} - V _{T-})	V _{CC} = 5 V	0.4	0.8		0.4	0.8		V
V _{IK}	V _{CC} = MIN, I _I = -18 mA			-1.5			-1.5	V
V _{OH}	V _{CC} = MIN, V _I = 0.5 V, I _{OH} = -0.4 mA	2.5	3.4		2.7	3.4		V
V _{OL}	V _{CC} = MIN, V _I = 1.9 V	I _{OL} = 4 mA		0.25	0.4		0.25	0.4
		I _{OL} = 8 mA					0.35	0.5
I _{T+}	V _{CC} = 5 V, V _I = V _{T+}	-0.14			-0.14			mA
I _{T-}	V _{CC} = 5 V, V _I = V _{T-}	-0.18			-0.18			mA
I _I	V _{CC} = MAX, V _I = 7 V	0.1			0.1			mA
I _{IH}	V _{CC} = MAX, V _I = 2.7 V	20			20			μA
I _{IL}	V _{CC} = MAX, V _{IL} = 0.4 V	-0.4			-0.4			mA
I _{OS} §	V _{CC} = MAX	-20		-100	-20		-100	mA
I _{CCH}	V _{CC} = MAX	5.9		11	5.9		11	mA
I _{CCL}	V _{CC} = MAX	8.2		14	8.2		14	mA

† For conditions shown as MIN or MAX, use the appropriate value specified under recommended operating conditions.

‡ All typical values are at V_{CC} = 5 V, T_A = 25°C.

§ Not more than one output should be shorted at a time, and duration of the short-circuit should not exceed one second.

switching characteristics, V_{CC} = 5 V, T_A = 25°C (see figure 1)

PARAMETER	FROM (INPUT)	TO (OUTPUT)	TEST CONDITIONS	MIN	TYP	MAX	UNIT
t _{PLH}	Any	Y	R _L = 2 kΩ, C _L = 15 pF		15	22	ns
t _{PHL}					15	22	ns

2
TTL Devices

SN54S132, SN74S132 QUADRUPLE 2-INPUT POSITIVE-NAND SCHMITT TRIGGERS

recommended operating conditions

	SN54S132			SN74S132			UNIT
	MIN	NOM	MAX	MIN	NOM	MAX	
V _{CC} Supply voltage	4.5	5	5.5	4.75	5	5.25	V
I _{OH} High-level output current			-1			-1	mA
I _{OL} Low-level output current			20			20	mA
T _A Operating free-air temperature	-55		125	0		70	°C

electrical characteristics over recommended operating free-air temperature range (unless otherwise noted)

PARAMETER	TEST CONDITIONS†	SN54S132			SN74S132			UNIT
		MIN	TYP‡	MAX	MIN	TYP‡	MAX	
V _{T+}	V _{CC} = 5 V	1.6	1.77	1.9	1.6	1.77	1.9	V
V _{T-}	V _{CC} = 5 V	1.1	1.22	1.4	1.1	1.22	1.4	V
V _{hys} (V _{T+} - V _{T-})	V _{CC} = 5 V	0.2	0.55		0.2	0.55		V
V _{IK}	V _{CC} = MIN, I _I = -18 mA			-1.2			-1.2	V
V _{OH}	V _{CC} = MIN, V _I = 1.1 V, I _{OH} = -1 mA	2.5	3.4		2.7	3.4		V
V _{OL}	V _{CC} = MIN, V _I = 1.9 V, I _{OL} = 20 mA			0.5			0.5	V
I _{T+}	V _{CC} = 5 V, V _I = V _{T+}		-0.9			-0.9		mA
I _{T-}	V _{CC} = 5 V, V _I = V _{T-}		-1.1			-1.1		mA
I _I	V _{CC} = MAX, V _I = 5.5 V			1			1	mA
I _{IH}	V _{CC} = MAX, V _I = 2.7 V			50			50	μA
I _{IL}	V _{CC} = MAX, V _{IL} = 0.5 V			-2			-2	mA
I _{OS} §	V _{CC} = MAX	-40		-100	-40		-100	mA
I _{CCH}	V _{CC} = MAX		28	44		28	44	mA
I _{CCL}	V _{CC} = MAX		44	68		44	68	mA

† For conditions shown as MIN or MAX, use the appropriate value specified under recommended operating conditions.

‡ All typical values are at V_{CC} = 5 V, T_A = 25°C.

§ Not more than one output should be shorted at a time, and duration of the short-circuit should not exceed one second.

switching characteristics, V_{CC} = 5 V, T_A = 25°C (see figure 1)

PARAMETER	FROM (INPUT)	TO (OUTPUT)	TEST CONDITIONS		MIN	TYP	MAX	UNIT
t _{PLH}	A or B	Y	R _L = 280 Ω,	C _L = 15 pF		7	10.5	ns
t _{PHL}						8.5	13	ns

2

TTL Devices

**SN54132, SN54LS132, SN54S132,
SN74132, SN74LS132, SN74S132
QUADRUPLE 2-INPUT POSITIVE-NAND SCHMITT TRIGGERS**

PARAMETER MEASUREMENT INFORMATION

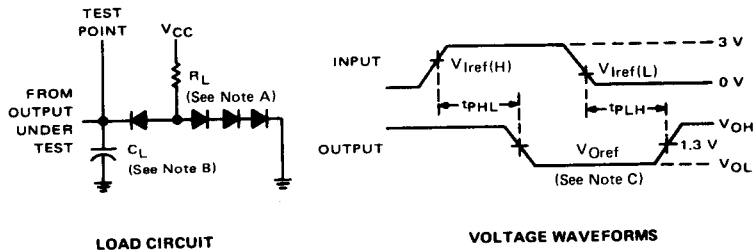

- NOTES: A. All diodes are 1N3064 or equivalent.
B. C_L includes probe and jig capacitance.
C. Generator characteristics and reference voltages are:

	Generator Characteristics				Reference Voltages		
	Z_{out}	PRR	t_r	t_f	$V_{I\ ref(H)}$	$V_{I\ ref(L)}$	$V_{O\ ref}$
SN54'/SN74'	50	1 MHz	10 ns	10 ns	1.7 V	0.9 V	1.5 V
SN54LS'/SN74LS'	50	1 MHz	15 ns	6 ns	1.6 V	0.8 V	1.3 V
'S132	50	1 MHz	2.5 ns	2.5 ns	1.8 V	1.2 V	1.5 V

FIGURE 1

2

TTL Devices

SN54132, SN74132
QUADRUPLE 2-INPUT POSITIVE-NAND SCHMITT TRIGGERS

TYPICAL CHARACTERISTICS OF '132 CIRCUITS

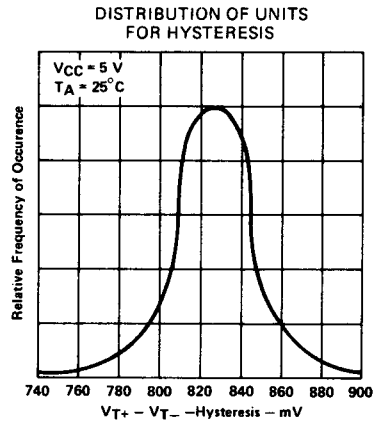
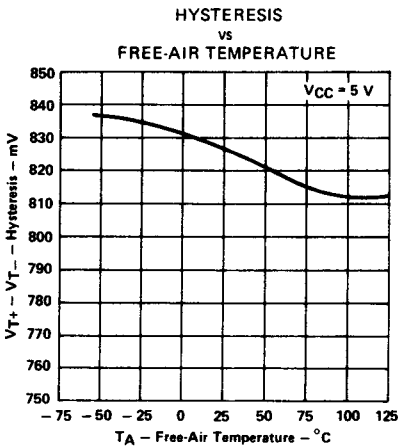
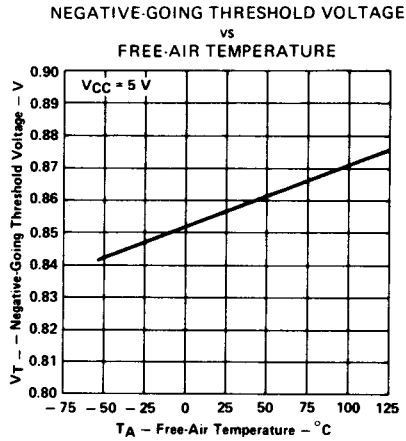
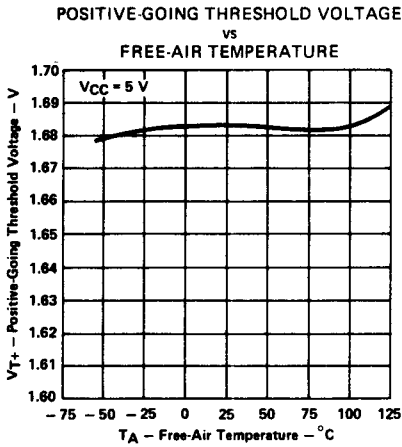

2

TTL Devices

† Data for temperatures below 0°C and 70°C and supply below 4.75 V and above 5.25 V are applicable for SN54132 only.

SN54132, SN74132
QUADRUPLE 2-INPUT POSITIVE-NAND SCHMITT TRIGGERS

TYPICAL CHARACTERISTICS OF '132 CIRCUITS

2

TTL Devices

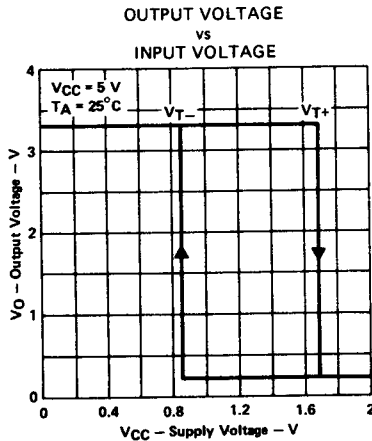
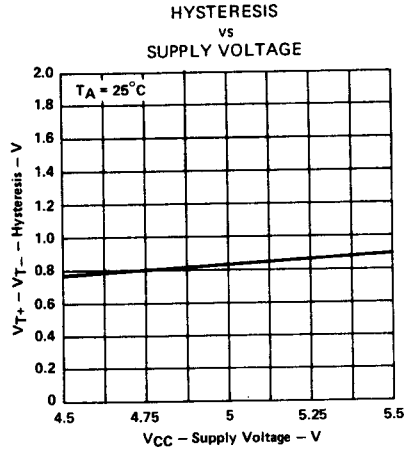
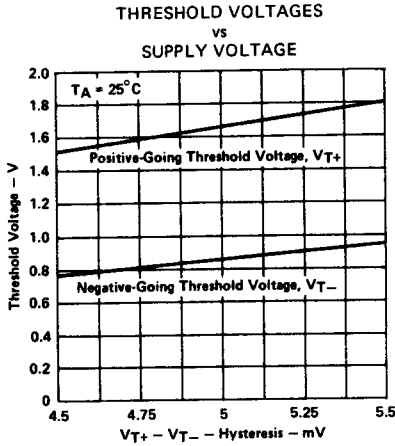

† Data for temperatures below 0°C and 70°C and supply below 4.75 V and above 5.25 V are applicable for SN54132 only.

SN54LS132, SN74LS132
QUADRUPLE 2-INPUT POSITIVE-NAND SCHMITT TRIGGERS

TYPICAL CHARACTERISTICS OF 'LS132 CIRCUITS

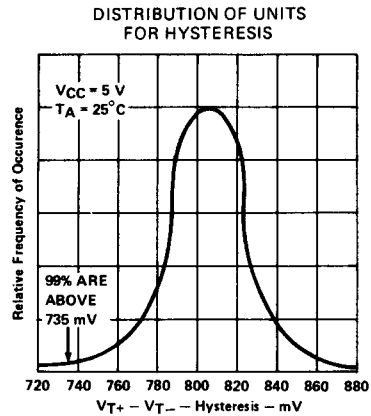
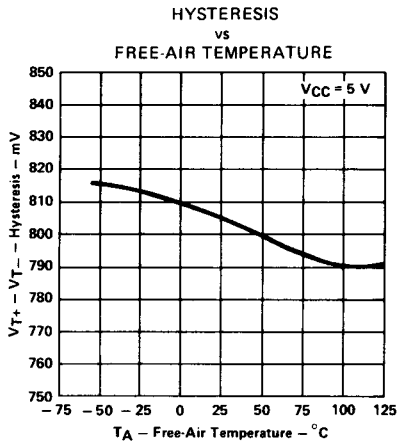
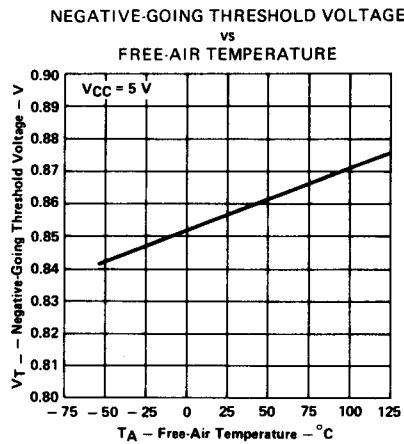
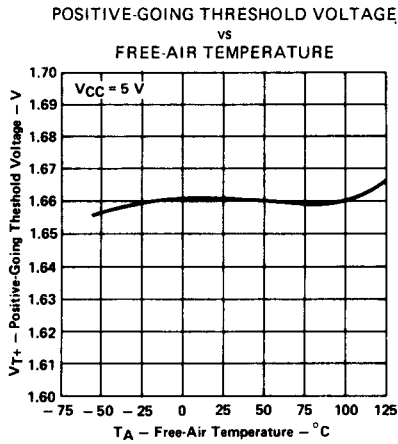

2

TTL Devices

† Data for temperatures below 0°C and above 70°C and supply voltages below 4.75 V and above 5.25 V are applicable for SN54LS132 only.

SN54LS132, SN74LS132
QUADRUPLE 2-INPUT POSITIVE-NAND SCHMITT TRIGGERS

TYPICAL CHARACTERISTICS OF 'LS132 CIRCUITS

THRESHOLD VOLTAGES AND HYSTERESIS
vs
SUPPLY VOLTAGE

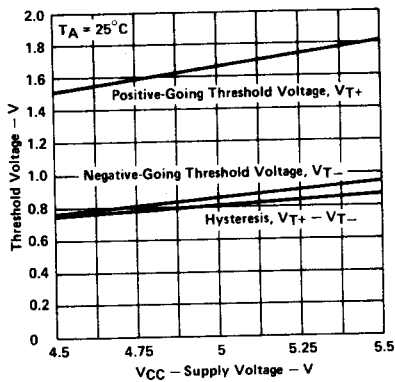

OUTPUT VOLTAGE
vs
INPUT VOLTAGE

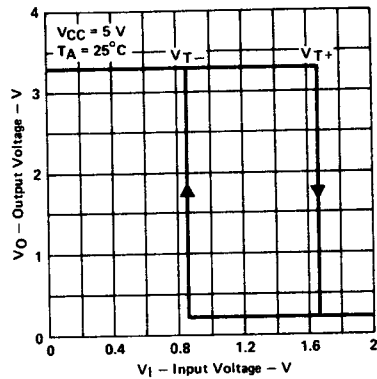

2

TTL Devices

[†] Data for temperatures below 0°C and above 70°C and supply voltages below 4.75 V and above 5.25 V are applicable for SN54LS132 only.

**SN54132, SN54LS132, SN54S132,
SN74132, SN74LS132, SN74S132
QUADRUPLE 2-INPUT POSITIVE-NAND SCHMITT TRIGGERS**

TYPICAL APPLICATION DATA

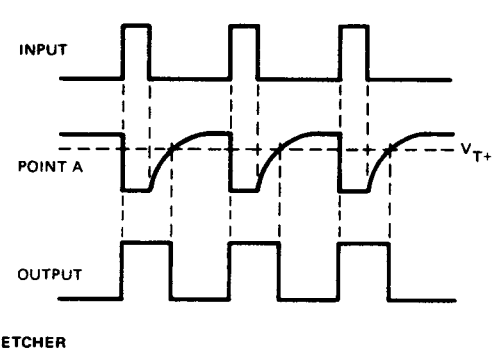
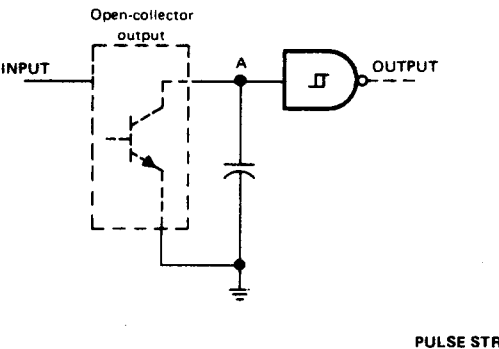
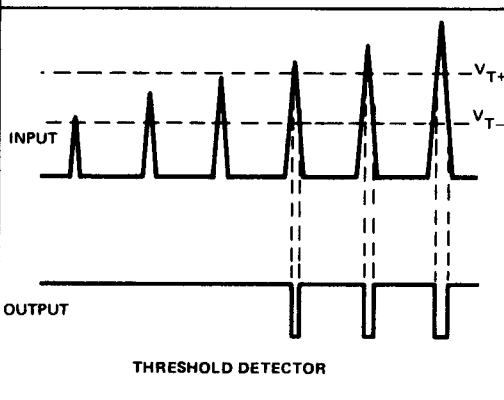
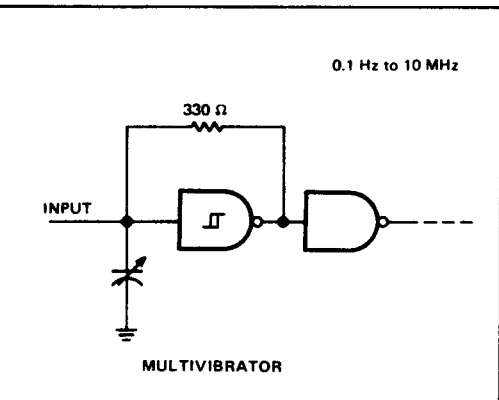
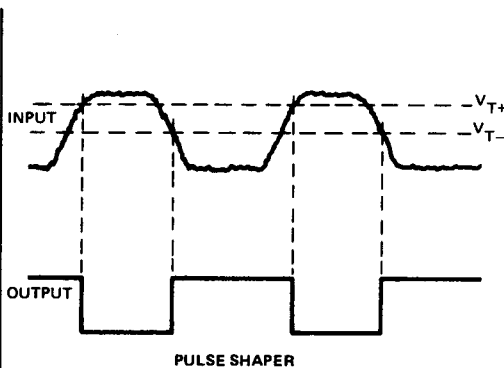
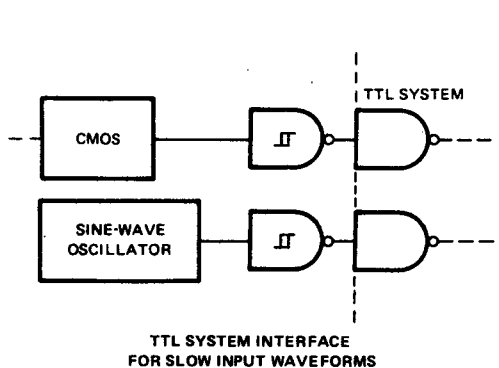

2

TTL Devices