

## Coded locking circuit for security systems

TEA5500  
TEA5500T

### GENERAL DESCRIPTION

The TEA5500 is an encoder/decoder circuit, for security systems. The system has the ability to transmit a complex code between an encoding and decoding unit by infrared radiation. The device can operate as an encoder or decoder depending on the external circuitry connected to the data input. The code is made by the 10 input pins E1 to E10 by connecting them either to ground (LOW) or to the positive supply (HIGH), or leaving them floating ( $\infty$ ). This allows  $3^{10}-2$  combinations. Two combinations are prohibited; E1 to E10 = HIGH and E1 to E9 = HIGH, E10 = LOW.

#### Encoding

In encoding mode the data input is connected to  $V_P$  and both outputs (S1, S2) are connected to a npn output transistor which drives (e.g.) an infrared radiation emitting diode.

After every start the encoder completes three coding runs then stops automatically.

#### Decoding

In decoding mode an infrared sensitive diode (e.g.) is connected to the data input via an amplifier. If the input data is recognized, the data input of the decoder is temporarily closed (disregarding immediately following data) and one of the outputs is activated for a predetermined time after which the following start will activate the other output.

If the input data is not recognized, neither of the outputs are activated and after the third coding run is completed the data input of the decoder is temporarily closed.

#### Output

The output is an open-collector configuration (npn), which is active LOW. It can handle a higher supply voltage than  $V_P$  (i.e. 16 V max.).

### QUICK REFERENCE DATA

parameter	conditions	symbol	min.	typ.	max.	unit
Supply voltage (pin 16)	$V_P = 4.5 \text{ V}$	$V_P$	3.0	4.5	6.5	V
Supply current (pin 16)		$I_P$	1.8	2.5	3.2	mA
Operating ambient temperature range		$T_{amb}$	-40	—	+80	$^{\circ}\text{C}$
Storage temperature range		$T_{stg}$	-50	—	+150	$^{\circ}\text{C}$
Total power dissipation		$P_{tot}$	—	—	500	mW
Maximum voltage at outputs (pins 3,4 )		$V_O$	—	—	16	V

### PACKAGE OUTLINES

TEA5500: 16-lead DIL; plastic (SOT38).

TEA5500T: 16-lead mini-pack; plastic (SO16L; SOT162A).

Coded locking circuit for security systems

TEA5500  
TEA5500T

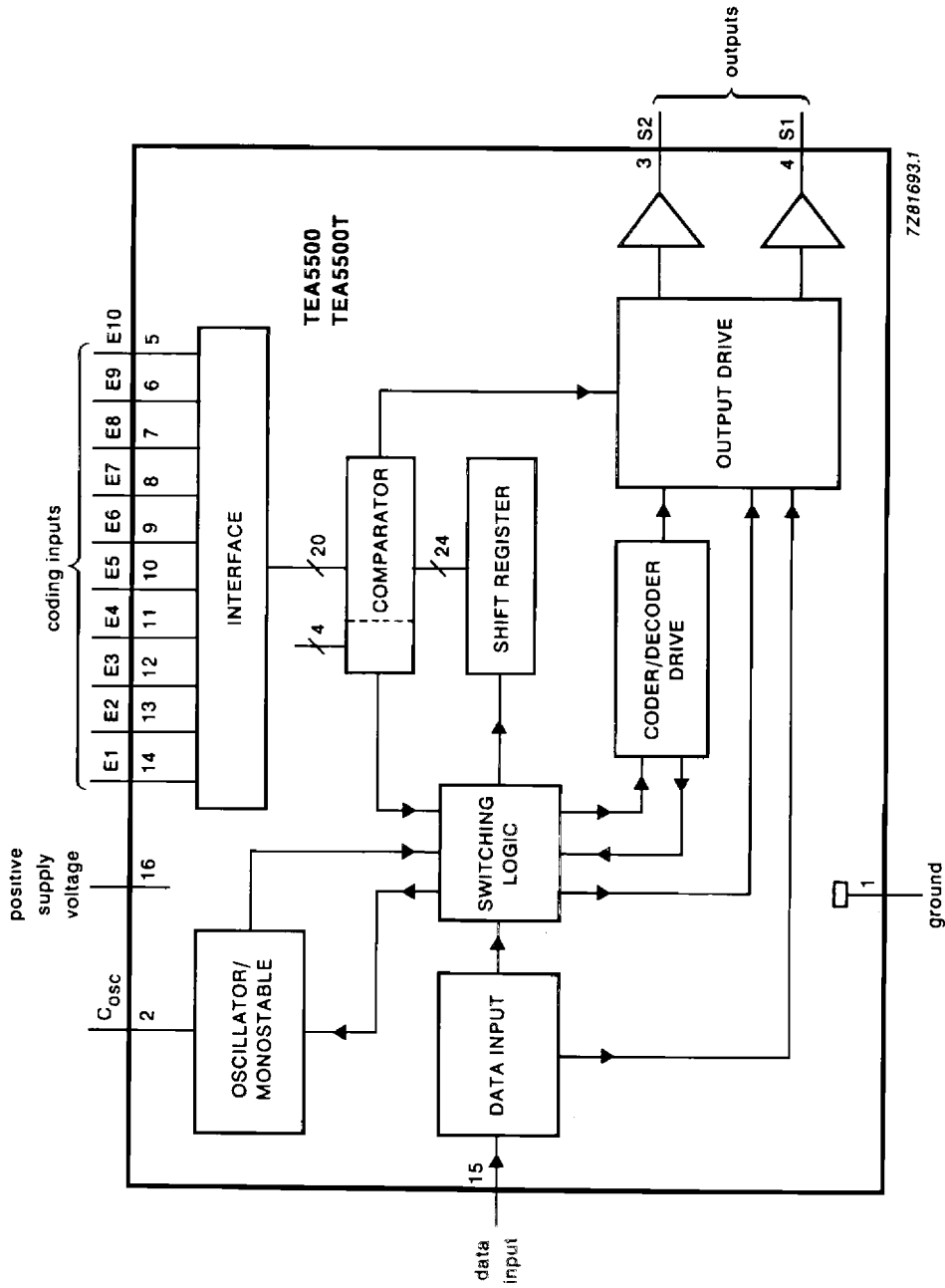

Fig. 1 Block diagram.

Coded locking circuit for security systems

TEA5500  
TEA5500T

**PINNING**

**Pin functions**

pin	mnemonic	description
1	GND	ground
2	C <sub>osc</sub>	oscillator capacitor
3	S2	output 2
4	S1	output 1
5	E10	coding inputs
6	E9	
7	E8	
8	E7	
9	E6	
10	E5	
11	E4	
12	E3	
13	E2	
14	E1	
15	DATA	data input
16	V <sub>p</sub>	positive supply voltage

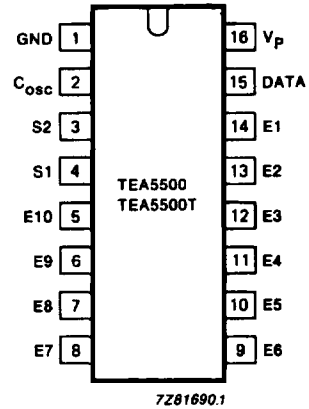

Fig. 2 Pinning diagram.

**RATINGS**

Limiting values in accordance with the Absolute Maximum System (IEC 134)

parameter	symbol	min.	max.	unit
Supply voltage (pin 16)	V <sub>p</sub>	—	7	V
Supply current (pin 16)	I <sub>p</sub>	0	50	mA
Input voltage (pins 2 and 5 to 15)	V <sub>I</sub>	-0.3	V <sub>p</sub> + 0.3	V
Voltage at outputs (pins 3 and 4)	V <sub>O</sub>	-0.3	16	V
Total power dissipation	P <sub>tot</sub>	—	500	mW
Storage temperature range	T <sub>stg</sub>	-50	+ 150	°C
Operating ambient temperature range	T <sub>amb</sub>	-40	+ 80	°C

**THERMAL RESISTANCE**

From junction to ambient

TEA5500: 16-lead DIL  
TEA5500T: 16-lead mini-pack

R<sub>th j-a</sub> = 125 K/W  
R<sub>th j-a</sub> = 160 K/W

## Coded locking circuit for security systems

TEA5500  
TEA5500T

## CHARACTERISTICS

 $T_{amb} = 25\text{ }^{\circ}\text{C}$ ; voltages with respect to pin 1; unless otherwise specified.

parameter	conditions	symbol	min.	typ.	max.	unit
<b>Supply</b>						
Supply voltage (pin 16)		$V_P$	3	4.5	6.5	V
Supply current	$V_P = 4.5\text{ V}$	$I_P$	1.8	2.5	3.2	mA
Zener diode voltage across supply	note 1	$V_Z$	—	—	8	V
<b>Inputs E1 to E10</b>						
Input voltage HIGH		$V_{IH}$	$V_P - 0.3$	—	—	V
Input voltage LOW		$V_{IL}$	—	—	0.3	V
Input voltage floating		$V_{IFL}$	1	—	$V_P - 1$	V
Input current HIGH		$I_{IH}$	2	7	12	$\mu\text{A}$
Input current LOW		$I_{IL}$	-4	-9	-15	$\mu\text{A}$
Input current floating		$I_{IFL}$	—	—	2	$\mu\text{A}$
<b>Data input</b>						
Input voltage						
for encoding mode		$V_{de}$	$V_P - 0.6$	$V_P$	$V_P + 0.3$	V
for decoding mode HIGH		$V_{ddH}$	0.8	—	$0.5 V_P$	V
for decoding mode LOW		$V_{ddL}$	—	—	0.5	V
Input current						
in encoding mode	$V_{15} = V_P = 4.5\text{ V}$	$I_{de}$	8	16	25	$\mu\text{A}$
in decoding mode HIGH	$V_{15} = 2\text{ V};$ $V_P = 4.5\text{ V}$	$I_{ddH}$	—	—	2	$\mu\text{A}$
in decoding mode LOW	$V_{15} = 0.3\text{ V};$ $V_P = 4.5\text{ V}$	$I_{ddL}$	-8	-16	-25	$\mu\text{A}$
Minimum pulse width of DATA input signal						
		$t_{dp}$	2	—	—	$\mu\text{s}$
<b>Output (pins 3 and 4)</b>						
Output sink current						
	output active; $V_P = 4.5\text{ V}$	$I_O$ (sink)	25	—	—	mA
Voltage at output						
		$V_O$	—	—	16	V

**Note to the supply characteristics**

- Maximum Zener diode current 10 mA.

## Coded locking circuit for security systems

TEA5500  
TEA5500T

parameter	conditions	symbol	min.	typ.	max.	unit
<b>Oscillator characteristics</b>						
V <sub>p</sub> = 4.5 V						
Switching voltage thresholds						
high level		V <sub>th</sub>	3.10	3.32	3.50	V
low level		V <sub>tl</sub>	0.65	0.71	0.90	V
Input current						
after switching high level		I <sub>th</sub>	27	36	45	μA
after switching low level		I <sub>tl</sub>	-6.7	-9	-11.3	μA
Ratio I <sub>th</sub> /I <sub>tl</sub>		ΔI <sub>osc</sub>	3	4	5	
Duration of oscillator pulse						
in coding mode	note 1	τ <sub>c</sub>	20	0.4 · C <sub>osc</sub> (pF)	—	μs
in decoding mode		τ <sub>d</sub>	3 · τ <sub>c</sub>	0.4 · C <sub>osc</sub> (pF)	5 · τ <sub>c</sub>	μs
Oscillator capacitor						
in coding mode	notes 1 and 2	C <sub>osc</sub>	56	—	—	pF
Duration of						
output active status		τ <sub>o</sub>	—	384 · τ <sub>d</sub>	—	
data input disabled status		τ <sub>x</sub>	—	576 · τ <sub>d</sub>	—	
Influence of temperature on						
duration of oscillator pulse		$\frac{\Delta\tau_c/\tau_c}{\Delta T}$	—	0.002	—	K <sup>-1</sup>
Influence of supply voltage on						
duration of oscillator pulse		$\frac{\Delta\tau_c/\tau_c}{\Delta V_p}$	—	—	0.16	V <sup>-1</sup>

**Notes to the oscillator characteristics**

1. Minimum value encoder — capacitor must provide minimum pulse width of DATA pulse τ<sub>dp</sub> (= 0.2 τ<sub>c</sub>).
2. Ratio encoder/decoder capacitor 1 : 4.

Coded locking circuit for security systems

TEA5500  
TEA5500T

Code

The code consists of 24 bits. Each bit is represented by presence or absence of a data pulse following a clock pulse. The first 10 pairs of bits are determined by the connections of the input pins (E1 to E10). The last 4 bits form the recognition code. For the corresponding code in decoding mode the order of the input pins is reversed and connections "low" (L) and "floating" ( $\infty$ ) are interchanged.

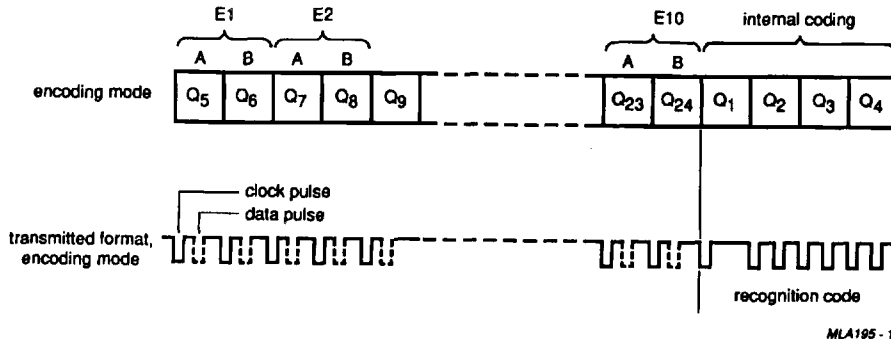

MLA195 - 1

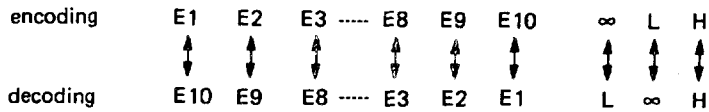

E	A	B	Q <sub>A</sub>	Q <sub>B</sub>
L	1	0	0	1
$\infty$	0	1	1	0
H	1	1	0	0

example

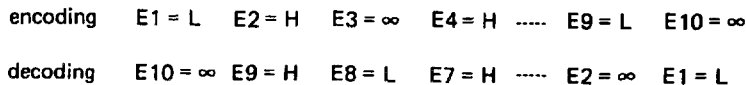

Fig. 3 Coding diagram.

# Coded locking circuit for security systems

TEA5500  
TEA5500T

## TIMING

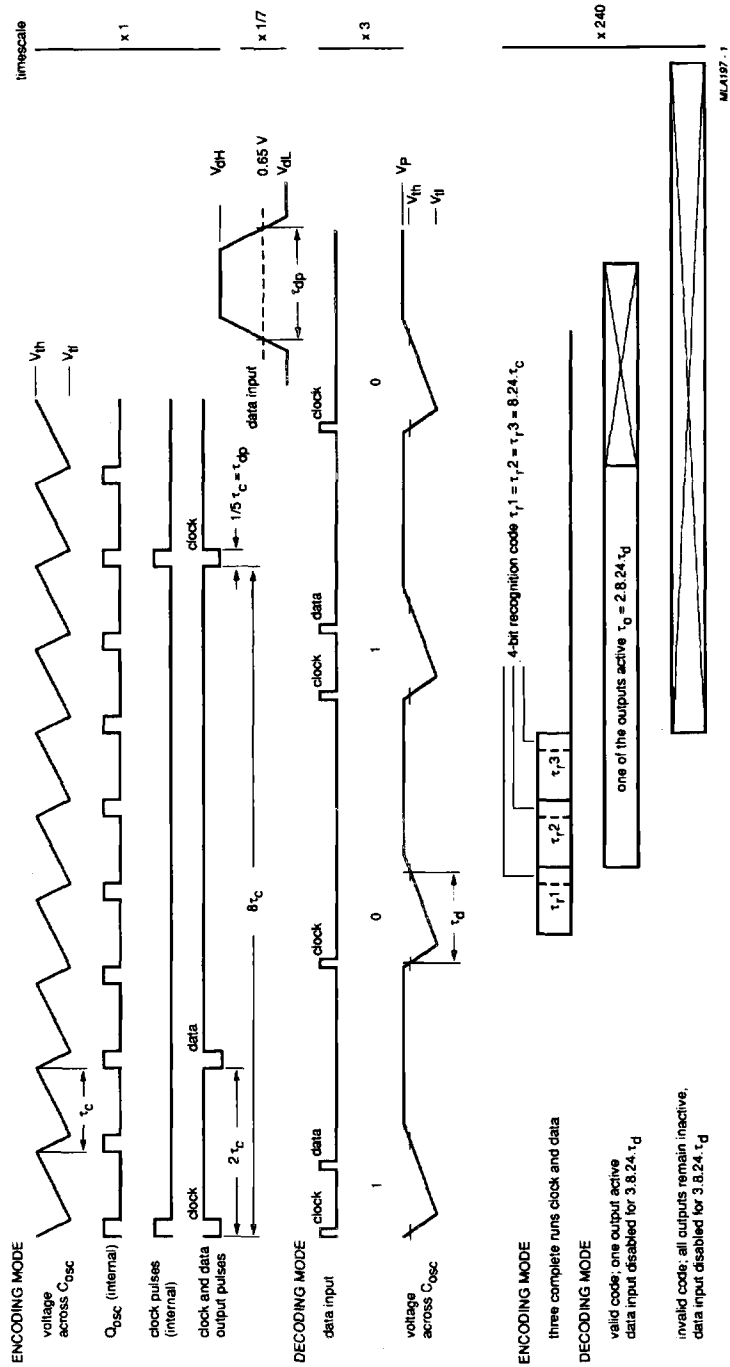
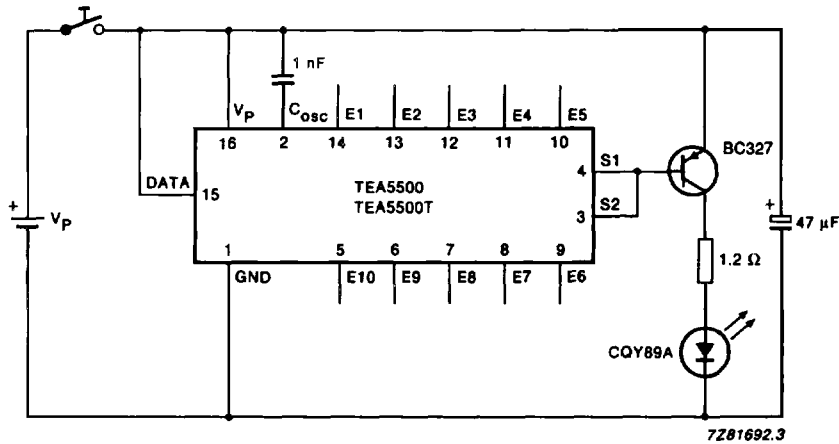

Fig. 4 Timing diagram of TEA5500.

Coded locking circuit for security systems

TEA5500  
TEA5500T

APPLICATION INFORMATION



E1 – E10: code (H,L, ∞).

Fig. 5 Application diagram; coding mode.

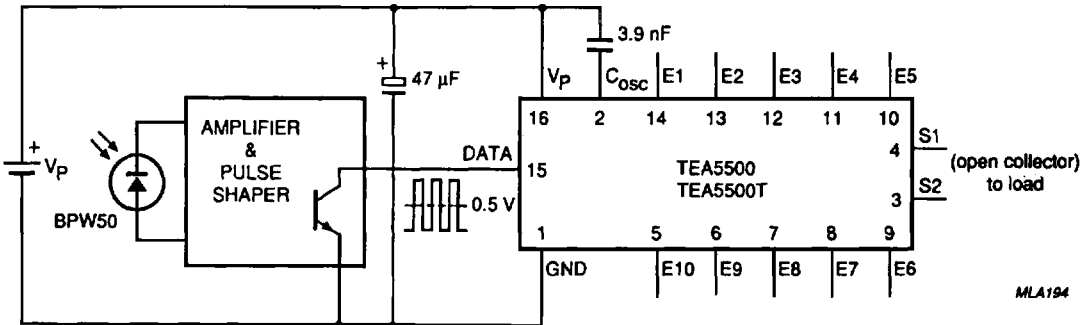

E10 – E1: code (H, ∞, L).

Fig. 6 Application diagram; decoding mode.



Coded locking circuit for security systems

TEA5500  
TEA5500T

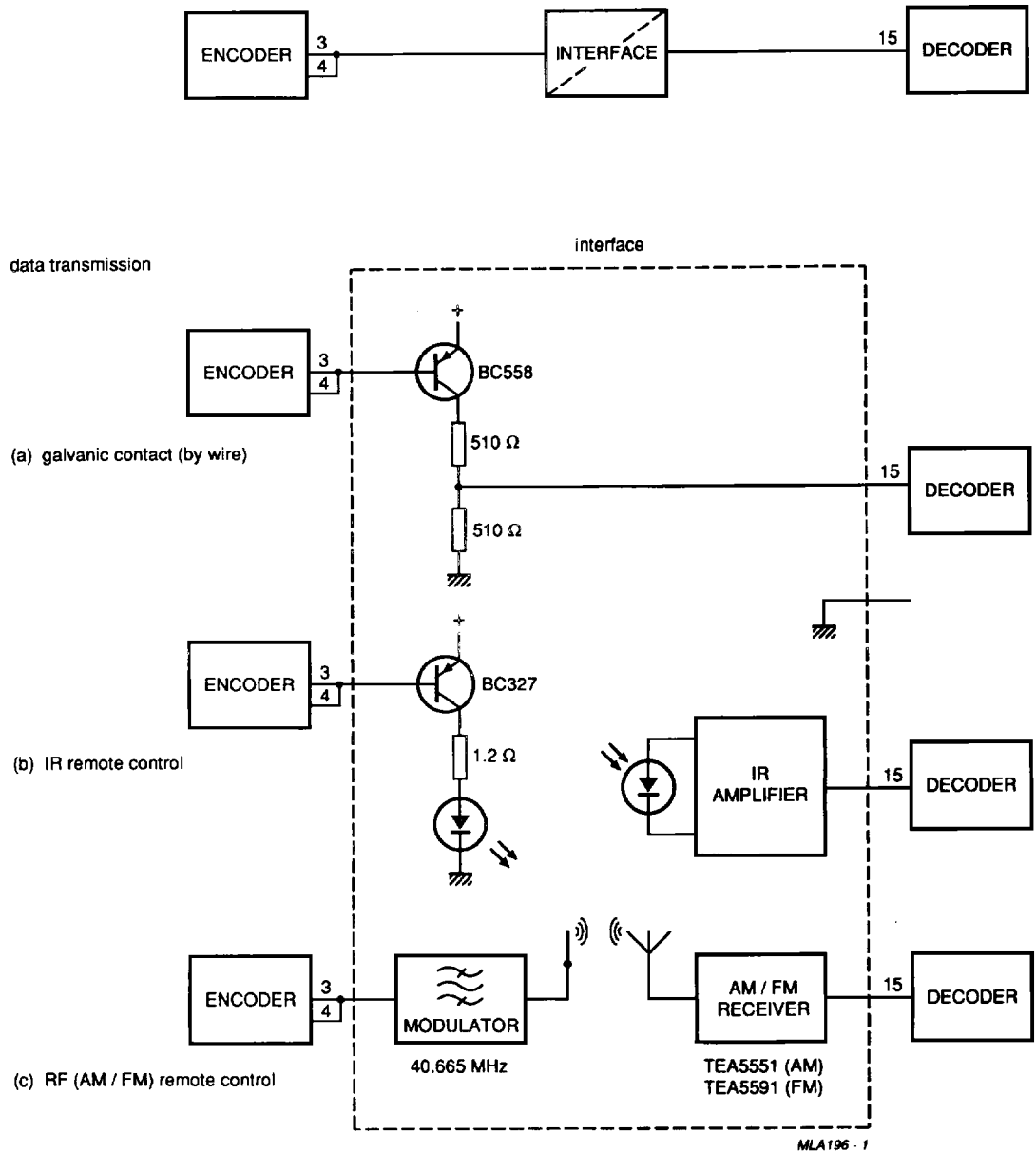

Fig. 7 Application diagram; types of data transmission possible by using different interfaces.