

FEATURES

- Sampling Rates from 1 kHz to 2 MHz
- DNL better than 1/2 LSB (typ) up to 1 MHz
- Very Low Power CMOS - 30 mW (typ)
- Monotonic; No Missing Codes
- Interface to any Input Range between GND and V_{DD}
- No S/H needed for Input Signals Less Than 10 kHz
- Single Power Supply (4 to 6.5 Volts)
- Latch-Up Free
- High ESD Protection: 4000 Volts Minimum
- For New Designs use MP8784 or XRD 6415

BENEFITS

- Reduced Board Space (Small Package)
- Reduced External Parts, No Sample/Hold Needed
- Suitable for Battery & Power Critical Applications
- Designer Can Adapt Input Range & Scaling

APPLICATIONS

- Low Power A/D Applications
- High Resolution Imaging
- Multiplexed Data Acquisition
- Radar Pulse Analysis

GENERAL DESCRIPTION

The MP7696 is a 9-bit CMOS Analog-to-Digital Converter designed for precision applications demanding *Low Power Consumption*. The input architecture of the MP7696 allows direct interface to any analog input range between AGND and AV_{DD} (0 to 2 V, 1 to 4 V, 0 to 5 V, etc.). The user simply sets $V_{REF(+)}$ and $V_{REF(-)}$ to encompass the desired input range.

The MP7696 uses a two-step flash technique. The first

segment converts the 3 MSBs and consists of 8 autobalanced comparators, latches, an encoder, and buffer storage registers. The second segment converts the remaining 6 LSBs.

With 30 mW power dissipation, the MP7696 achieves its excellent performance due to the inherent high speed of our proprietary 2 μ Refractory Molybdenum CMOS Process.

5

SIMPLIFIED BLOCK AND TIMING DIAGRAM

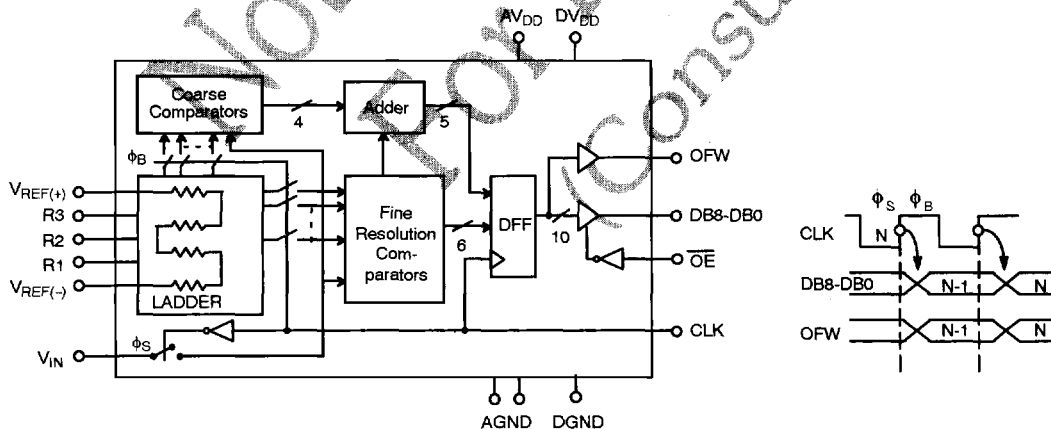

ORDERING INFORMATION

Package Type	Temperature Range	Part No.	DNL (LSB)	INL (LSB)
Plastic Dip	-40 to +85°C	MP7696AN	±1	±1
SOIC	-40 to +85°C	MP7696AS	±1	±1

PIN CONFIGURATIONS

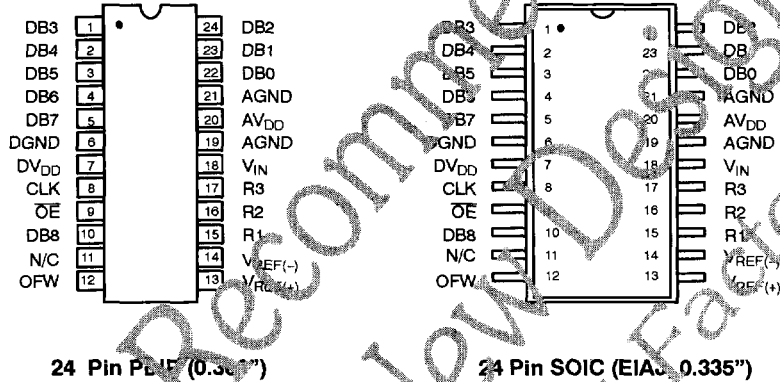

PIN OUT DEFINITIONS

PIN NO.	NAME	DESCRIPTION
1	DB3	Data Output Bit 3
2	DB4	Data Output Bit 4
3	DB5	Data Output Bit 5
4	DB6	Data Output Bit 6
5	DB7	Data Output Bit 7
6	DGND	Digital Ground
7	DV _{DD}	Digital V _{DD}
8	CLK	Clock Input
9	OE	Output Enable (Active Low)
10	DB8	Data Output Bit 8 (MSB)
11	N/C	No Connection
12	OFW	Overflow Output

PIN NO.	NAME	DESCRIPTION
13	V _{REF} (+)	Upper Reference Voltage
14	V _{REF} (-)	Lower Reference Voltage
15	R1	Reference Ladder Tap
16	R2	Reference Ladder Tap
17	R3	Reference Ladder Tap
18	V _{IN}	Analog Signal Input
19	AGND	Analog Ground
20	AV _{DD}	Analog V _{DD}
21	AGND	Analog Ground
22	DB0	Data Output Bit 0 (LSB)
23	DB1	Data Output Bit 1
24	DB2	Data Output Bit 2