

M56693FP/GP

Bi-CMOS & DMOS 32BIT SERIAL-INPUT LATCHED DRIVER

DESCRIPTION

The M56693 is a semiconductor integrated circuit that has a built-in, 32-bit shift register and a latch of CMOS structure with serial input and serial/parallel output, and a 32-bit totem-pole-type parallel output driver of high pressure proof DMOS structure. Employed are Bi-CMOS and high pressure proof DMOS processing technology.

FEATURES

- Serial input-serial/parallel output
- Cascade connections possible through serial output
- Latch circuit included for each stage
- Driver supply voltage: $V_H=120V$
- Operating temperature: $-20 - 75^{\circ}C$

APPLICATION

Vacuum Fluorescent Display ANODE DRIVER

FUNCTION

The M56693 comprises a 32-bit D type flip-flop with a 32 latches connected to its output.

In accordance with truth table 1, inputting data to SIN and clock pulse to \overline{CLK} allows SIN signal to be put into the internal shift register when the clock changes from "H" to "L", and simultaneously shift register data to be shifted sequentially.

Serial output SOUT is used by connecting to the next stage M56693 SIN when more than one M56693 is used to expand bits in the series.

In accordance with truth table 2, parallel output allows the latch to pass data through if LAT input is turned to "H", and data to be retained if LAT is turned to "L". Driver output HVO_n allows data from the latch to be output if BLK input is turned to "L", and "L" to be output if BLK input is turned to "H", irrespective of data from the latch.

PIN CONFIGURATION (TOP VIEW)

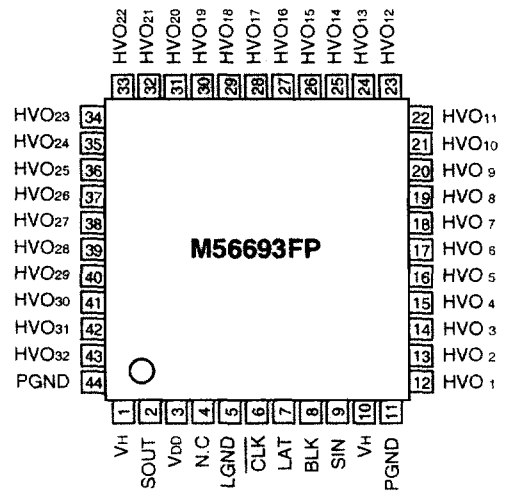

Outline 44P6N-A (FP)

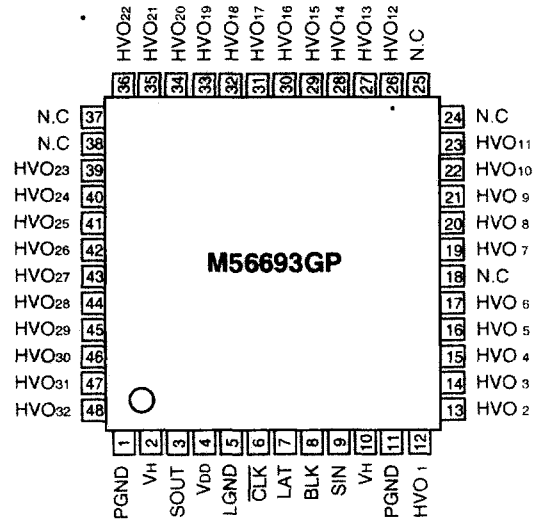

Outline 48P6D-A (GP)

N.C.: no connection

M56693FP/GP

Bi-CMOS & DMOS 32BIT SERIAL-INPUT LATCHED DRIVER

BLOCK DIAGRAM (Note : Pin No. in parentheses are of M56693GP)

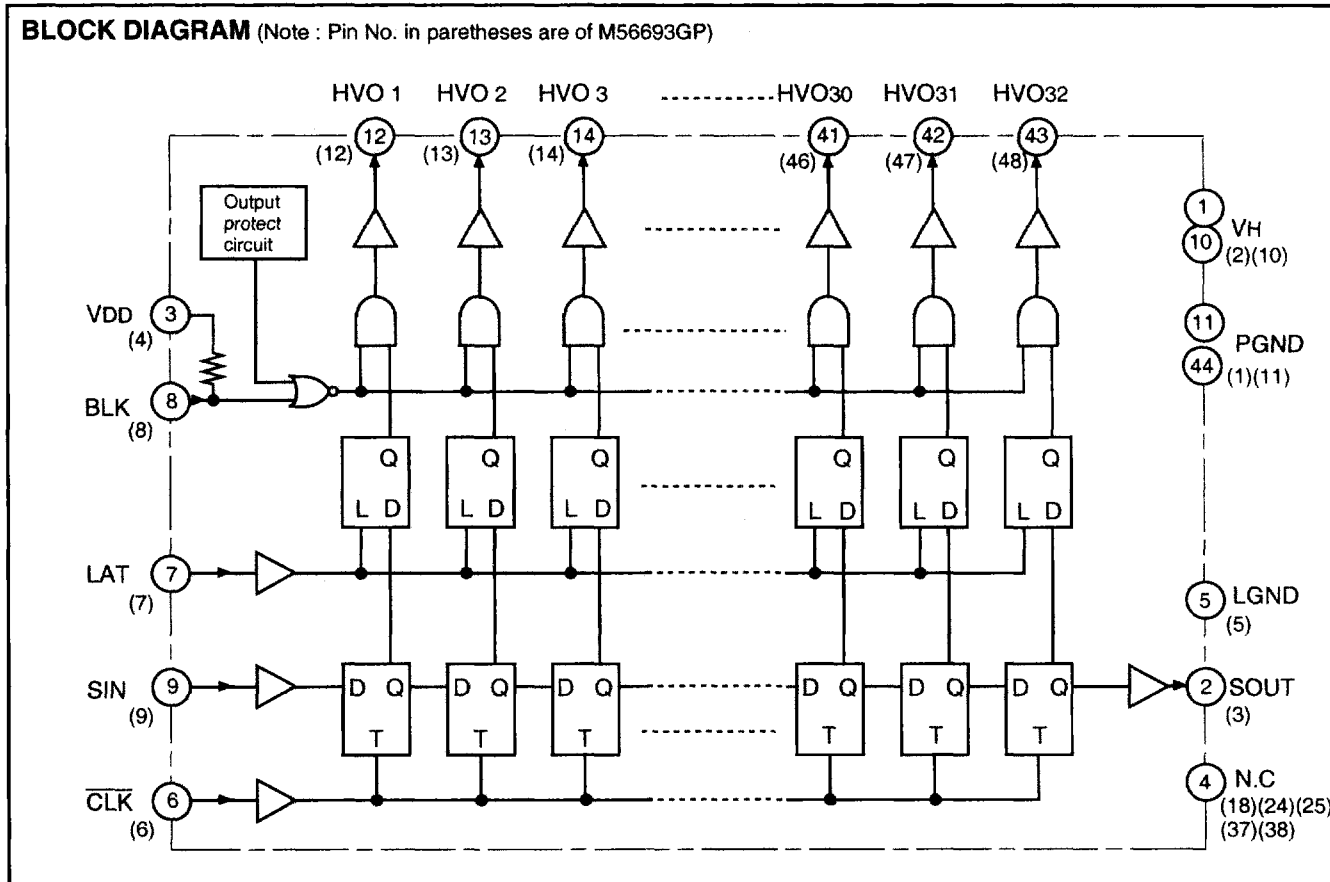

TRUTH TABLE

Truth table 1. Shift register section

CLK	Shift register operation
↓	DATA is shifted.
H or L	No changes.

Truth table 2. Latch and driver sections

D _n	LAT	BLK	HVOn
X	X	H	Output all "L"
H	H	L	H
L	H	L	L
X	L	L	Latch's data output.

D_n=nth bit DFF retention data
 HVOn=nth bit driver output
 L="L" level
 H="H" level
 X="L" level or "H" level

PIN FUNCTION DESCRIPTION

Pin name	Function
V _{DD}	Logic stage supply voltage
LGND	Logic stage ground
V _H	Output stage supply voltage
PGND	Output stage ground
$\overline{\text{CLK}}$	Clock input for the internal shift register. The data enter the internal shift registers and the data in the shift registers will be shifted in order by High to Low change of the clock.
SIN	Serial data input
SOUT	Serial data output
LAT	Latch input. When the LATCH is set to "H", the data in the shift register will enter the each latch circuit. When the LATCH input is set to "L", the data will be held.
BLK	Enable input for output control. When the BLK input is set to "L", data in the latch circuit will appear at outputs. When the BLK input is set to "H", all outputs will be set to "L".
HVO1 - 32	Output driver (push-pull)

ABSOLUTE MAXIMUM RATINGS (Ta=25°C, unless otherwise noted)

Symbol	Parameter	Conditions	Ratings	Unit
V _{DD}	Logic stage supply voltage		-0.3 - 7	V
V _H	Output stage supply voltage		-0.3 - 120	V
V _I	Logic inputs voltage		-0.3 - V _{DD} +0.3	V
V _O	Logic outputs voltage	Data output	-0.3 - V _{DD} +0.3	V
V _{HVO}	Outputs voltage	High supply voltage output pin	-0.3 - V _H	V
P _d	Power dissipation range	Ta ≤ 25°C	940	mW
T _{stg}	Storage temperature range		-55 - 150	°C

RECOMMENDED OPERATING CONDITIONS

Symbol	Parameter	Conditions	Ratings	Unit
V _{DD}	Supply voltage		4.5 - 5.5	V
V _H	Supply voltage		10 - 110	V
Topr	Operating temperature		-20 - 75	°C

ELECTRICAL CHARACTERISTICS (V_{DD}=5V, V_H=110V and Ta=25°C, unless otherwise noted)

Symbol	Parameter	Test conditions	Limits			Unit	
			Min.	Typ.	Max.		
I _{DD}	Supply current 1	No load		1	2	mA	
I _H	Supply current 2	Output all "L", no load		0	50	μA	
		Output all "H", no load		2	4	mA	
I _{IH}	"H" input current	V _{IH} =5V		0	2	μA	
I _{IL}	"L" input current	V _{IL} = 0V	SIN, LAT, $\overline{\text{CLK}}$		0	-2	μA
			BLK		-20	-100	μA
V _{HVOH}	Driver output voltage	I _{HVOH} = -0.5mA	100	106		V	
V _{HVOL}		I _{HVOL} = 0.5mA		0.7	2		
V _{OH}	Logic output voltage	I _{OH} = -0.1mA	4.5	4.95		V	
V _{OL}		I _{OL} = 0.1mA		0.04	0.4		
I _{HVOH}	"H" output current	High supply voltage output pin		-1	-3	mA	
I _{HVOL}	"L" output current	High supply voltage output pin		1	3	mA	
V _{TH}	Output protect operating voltage			3.4		V	
V _{TL}				3.1		V	

M56693FP/GP

Bi-CMOS & DMOS 32BIT SERIAL-INPUT LATCHED DRIVER

SWITCHING CHARACTERISTICS (V_{DD}=5V, V_H=110V and T_a=25°C, unless otherwise noted)

Symbol	Parameter	Test conditions	Limits			Unit
			Min.	Typ.	Max.	
f _{CLK}	Clock frequency	Duty = 45 – 55%			8	MHz
t _{PLH(SO)}	Logic output propagation time	CL = 15pF		120	300	ns
t _{PHL(SO)}				100	300	ns
t _{PLH(OUT)}	Driver output propagation time	RO = 220KΩ CO = 50pF		1	2	μs
t _{PHL(OUT)}				0.16	1	μs
t _{ROUT}	Driver output rise and fall time			1.3	2.5	μs
t _{FOUT}				0.35	2	μs

TEST CIRCUIT

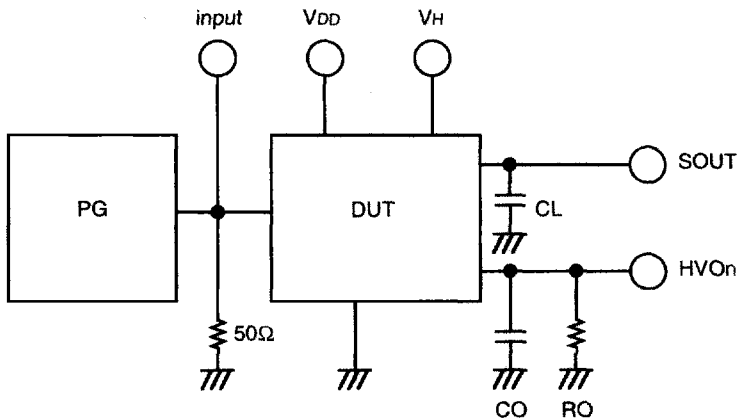

- (1) Pulse generator characteristics
tr ≤ 20ns tf ≤ 20ns
- (2) Capacitance CL includes connection floating capacitance and probe input capacitance.
: RO = 220KΩ
: CO = 50pF

TIMING WAVEFORM

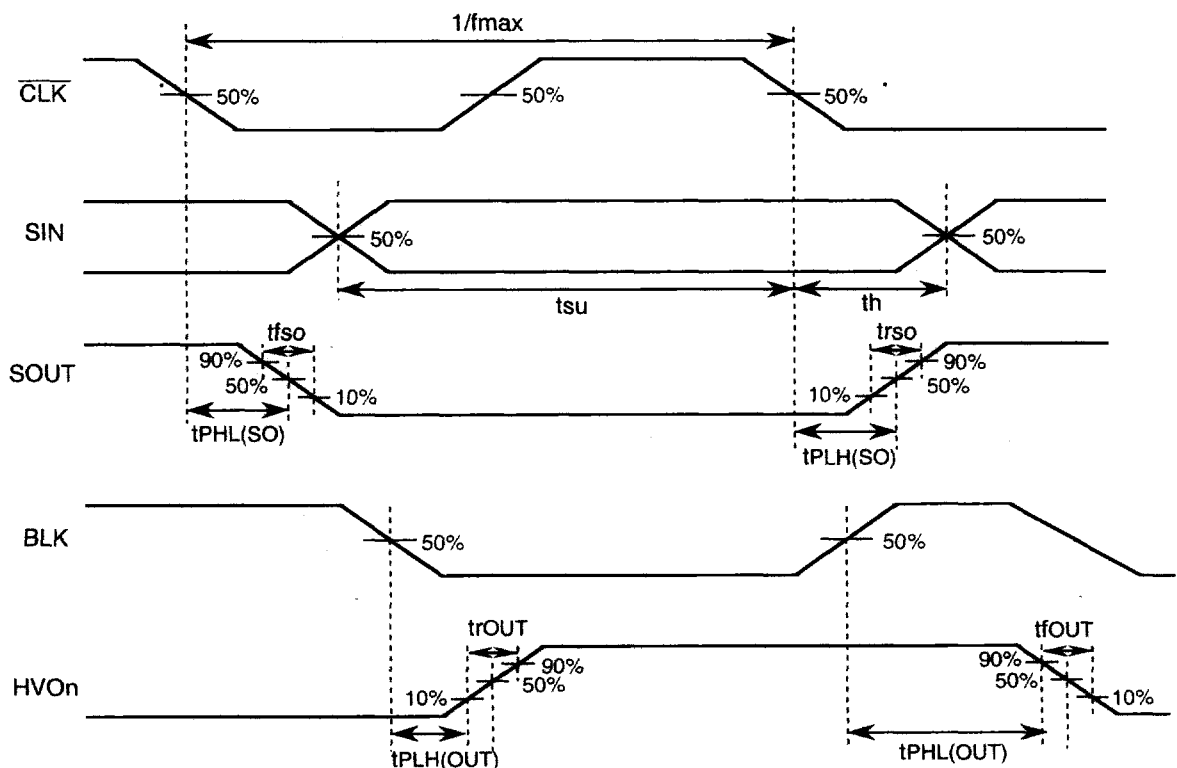

TYPICAL CHARACTERISTICS

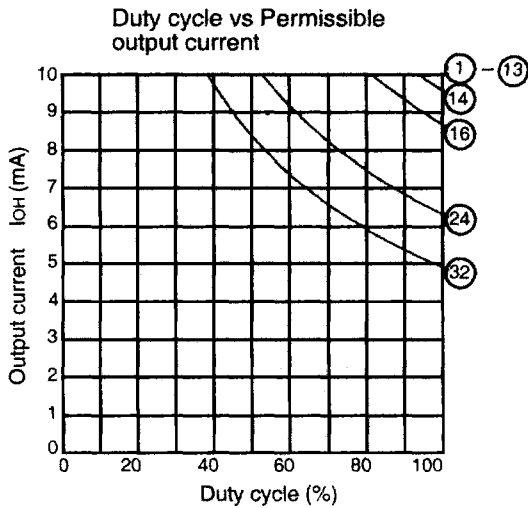
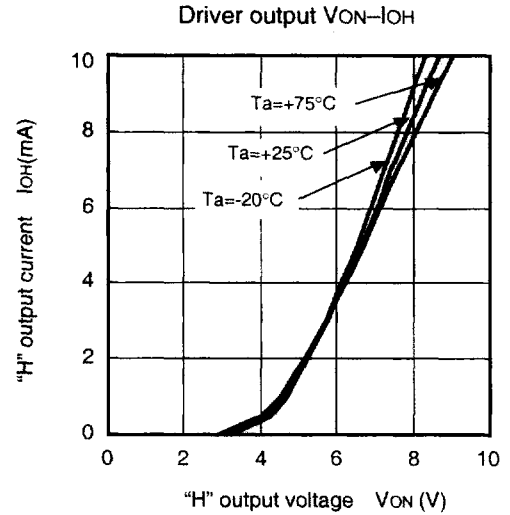
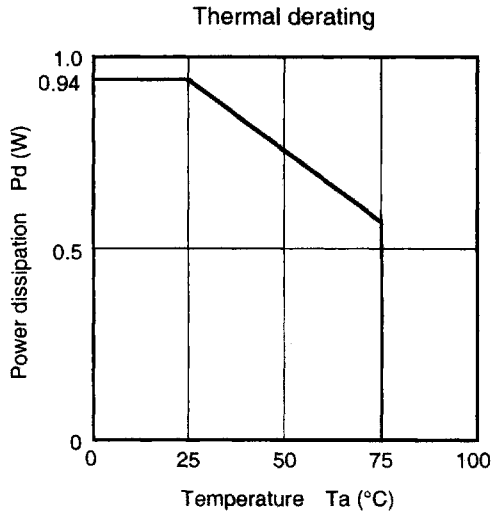

- Note • $T_a=25^{\circ}\text{C}$
- Repeated frequency >100Hz
 - Figure in the circle represents the number of concurrently operating output circuits.
 - Current value denotes a numerical value per circuit.

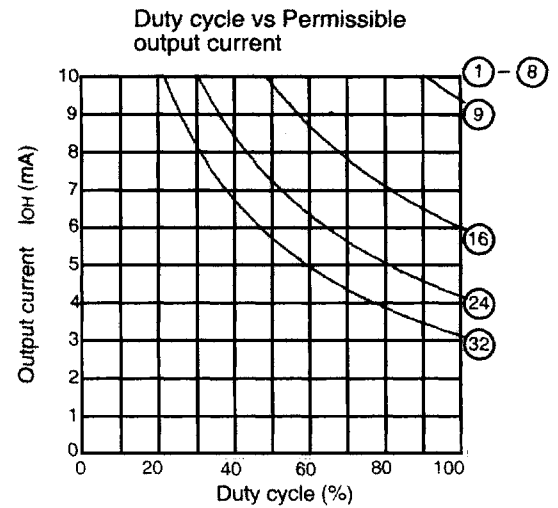

- Note • $T_a=75^{\circ}\text{C}$
- Repeated frequency >100Hz
 - Figure in the circle represents the number of concurrently operating output circuits.
 - Current value denotes a numerical value per circuit.

- Note 1. $V_{DD}=5\text{V}$ and $V_H=110\text{V}$, unless otherwise noted
2. Thermal derating characteristics represent those of an individual IC unit.
3. Allowable duty cycle output current characteristics represent that when a standard substrate is mounted. (Standard substrate: 70x70x1.6mm glass epoxy)