

DIO5662

37V Step-Up LED Driver with PWM to Constant Current Dimming Mode

Features

- Drive up to 10 serial LEDs
- PWM to Constant Current dimming mode
- Integrated 40V high current switch (1.3A limit)
- Wide V_{IN} Input Range: 2.7V~5.5V
- Dimming scheme up to 100:1 range
- Up to 86% PWM converter Efficiency
- Low 300mV feedback voltage
- LED open-circuit (OVP) protection: 37V
- High switching frequency: 1.1MHz
- For Compact Solution Size
- Integrated Soft start
- < 1 μ A shutdown current
- Compact SOT23-6, TSOT23-6, DFN2*2-6 Package
- Green compliant
- -40 to 85 °C Temperature range

Applications

- LED backlighting
- Mobile Phones
- Handheld Devices
- Digital Photo Frames
- Automotive Navigation

Descriptions

DIO5662 is a serial white LED driver, featuring an architecture of 86% high-efficiency current mode boost converter, driving up to 10 serial LEDs or a 3x13(3LEDs in rows) LED matrix. And it adopts PWM to Constant Current dimming control mode, with wide frequency range from 200Hz to 200kHz (The dimming frequency above 10kHz is recommended). The serial configuration assures the very most brightness consistency of the whole LED array.

DIO5662 works on 1.1MHz switching frequency, which can maximize current output of 1.3A limit and achieve high current conversion efficiency and result in external compact component size. Additionally, the total external component number is minimized due to the integrated low-side power MOSFET.

DIO5662 integrates multiple protection features, such as LED open-circuit protection, thermal shutdown protection and cycle-by-cycle input current limit protection. And the built-in soft start circuit limits inrush current when the circuit starts.

Ordering Information

Order Part Number	Top Marking		T_A	Package	
DIO5662ST6	62YW	Green	-40 to 85°C	SOT23-6	Tape & Reel, 3000
DIO5662TST6	62YW	Green	-40 to 85°C	TSOT23-6	Tape & Reel, 3000
DIO5662CD6	D62	Green	-40 to 85°C	DFN2*2-6 E	Tape & Reel, 3000

Pin Assignment

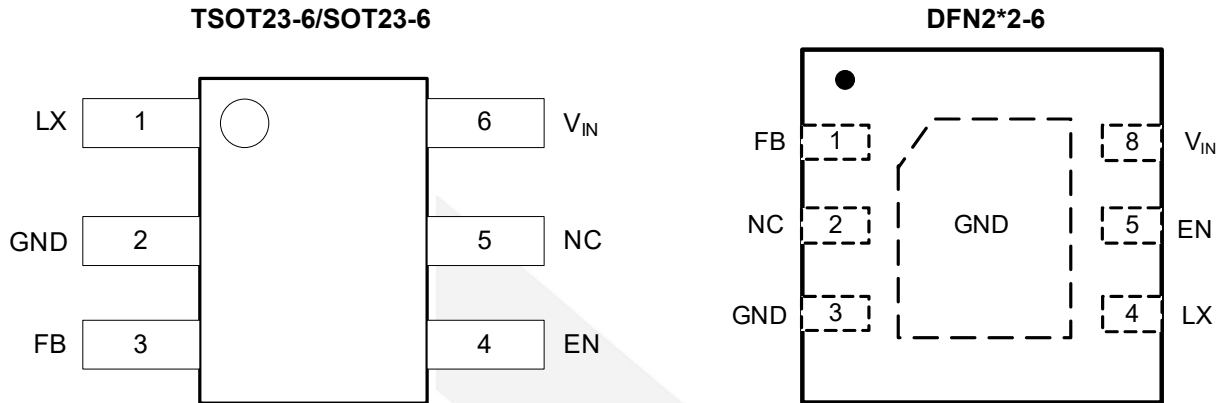

Figure 1 Top View

Pin Descriptions

Name	Description
LX	Converter switching node
GND	Converter/IC ground
FB	Output feedback pin regulated at 0.3V
EN	IC enable and PWM dimming control pin
NC	No connected
V _{IN}	IC supply voltage



DIO5662

37V Step-Up LED Driver with PWM to Constant Current Dimming Mode

Absolute Maximum Ratings

Stresses beyond those listed under "Absolute Maximum Rating" may cause permanent damage to the device. These are stress ratings only and functional operation of the device at these or any other condition beyond those indicated in the operational sections of the specifications is not implied. Exposure to absolute maximum rating conditions for extended periods may affect device reliability.

Parameter		Rating	Unit
Supply Voltage / V_{IN}		-0.3 to 6.0	V
High Voltage Nodes / LX		-0.3 to 40	V
Other pins / FB, EN		-0.3 to $V_{IN} + 0.3$	V
Operating Temperature Range / T_J		-40 to 150	°C
Storage Temperature Range / T_S		-65 to 150	°C
Lead Temperature Range / T_{LEAD}		300	°C
Thermal Resistance / θ_{JA}	SOT23-6/TSOT23-6	190	°C/W
	DFN2*2-6	140	
Maximum Power Dissipation at $T_A < 25^\circ\text{C}$		0.526	W
ESD	HBM, JEDEC: JESD22-A114	4	kV
	CDM, JEDEC: JESD22-C101	2	kV

Recommend Operating Conditions

The Recommended Operating Conditions table defines the conditions for actual device operation. Recommended Operating conditions are specified to ensure optimal performance to the datasheet specifications. DIOO does not Recommend exceeding them or designing to Absolute Maximum Ratings.

Parameter	Rating	Unit
Supply Voltage	2.7 to 5.5	V
Operating Temperature Range	-40 to 85	°C



DIO5662

37V Step-Up LED Driver with PWM to Constant Current Dimming Mode

Electrical Characteristics

Typical value: $V_{CC}=3.6V$, $T_A = 25^{\circ}C$, unless otherwise specified.

Symbol	Parameter	Conditions	Min.	Typ.	Max.	Unit
IC Supply						
V_{IN}	Input operating range		2.7		5.5	V
$UVLO_{HYST}$	UVLO hysteresis			0.22		V
I_Q	IC quiescent current(non switching)	FB=0.4V		0.22		mA
	IC quiescent current(switching)	FB=0V		0.67		mA
I_{SHDN}	V_{IN} pin shutdown current	EN=GND			0.1	μA
Boost Converter						
FB	FB pin accuracy		0.294	0.3	0.306	V
I_{FB}	FB pin bias current			0.1		μA
$R_{DS(ON)}$	NMOS on-resistance			0.4		Ω
I_{LX}	LX pin leakage current			0.1		μA
I_{LIM}	Peak NMOS current limit		1.0	1.3	1.6	A
F_{SW}	Oscillator frequency			1.1		MHz
D_{MAX}	Maximum duty cycle			95		%
OVP	Over voltage threshold, Measured at V_{OUT} pin			37	39	V
T_S	Start-up time			1		ms
Logic Signal						
V_{TH-L}	Logic low threshold				0.4	V
V_{TH-H}	Logic high threshold		1.4			V
T_{OFF}	EN low to shutdown time			2		ms
F_{EN}	Dimming frequency		0.2		200	kHz
T_{J-TH}	IC junction thermal shutdown threshold			146		$^{\circ}C$
	IC junction thermal shutdown hysteresis			19		$^{\circ}C$

Specifications subject to change without notice.

Application Circuit

In typical application, DIO5662 is competent in the below two configurations: 10 series LED-Array and 3(row)x13 LED Matrix. As depicted in following figures:

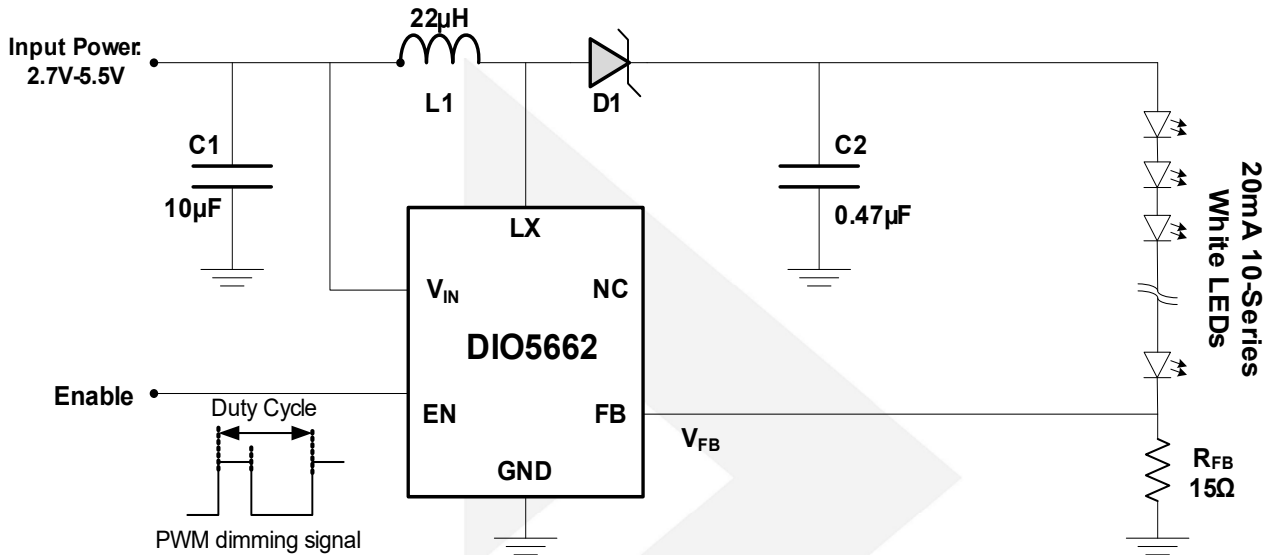

Figure 2. 10 Series LED Array Application Circuit Configuration

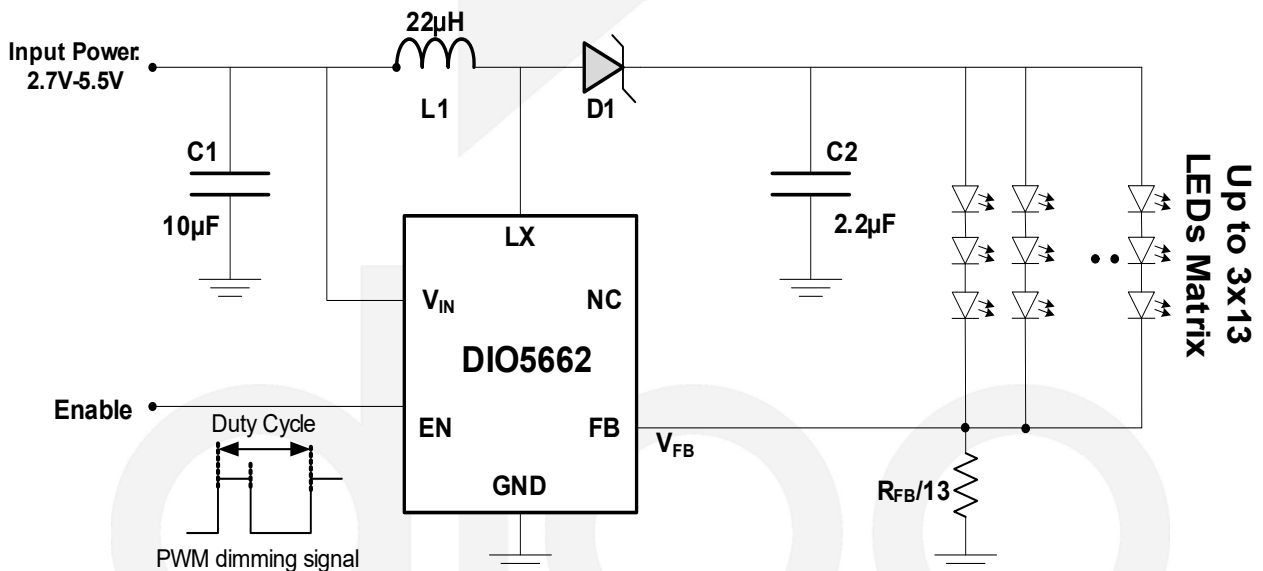

Figure 3. 3x13 (3 LEDs in row) LED Matrix Application Circuit Configuration

Note: A 22µH inductor is recommended for DIO5662.

Functional Block Diagram

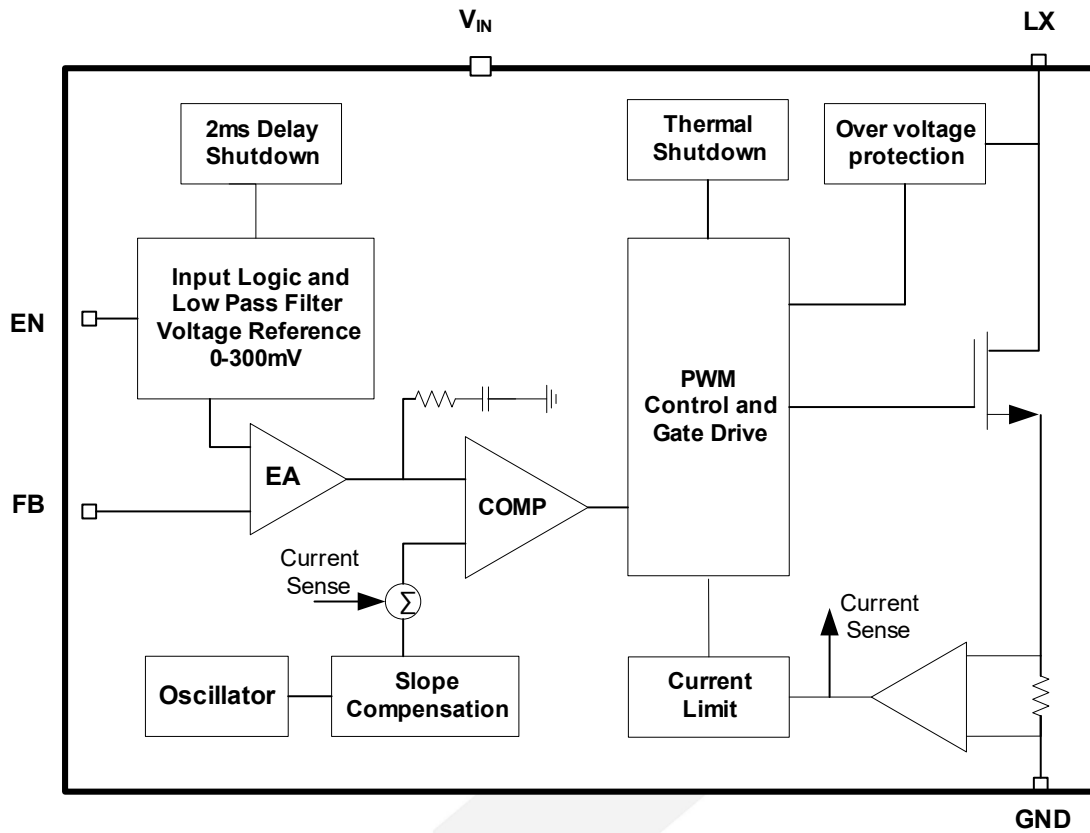

Figure 4. Functional Block Diagram



Operation Principle

DIO5662 utilizes a constant frequency current-mode boost converter architecture to power white LED strings or arrays by pumping current precisely regulated by feedback voltage V_{FB} and feedback resistor R_{FB} , illustrated in Figure 6, Page 8.

As illuminated in the Functional Block Diagram above, PWM Control and Gate Drive Block periodically opens and closes the Power MOSFET synchronized with Oscillator. At the rising edge of Oscillator pulse, Power MOSFET is turned on, while closed when the comparator tells the Current Sense slope ramp goes above the output "difference" of error amplifier EA. The Current Sense slope ramp is generated by Current Sense from sampling inductor charging current and compensated by Slope Compensation. And the output "difference" comes from comparing feedback voltage V_{FB} with internal reference voltage V_{REF} by Error Amplifier EA. Both the two close loops assure the output current stabilization and make feedback voltage V_{FB} in consistency with reference voltage V_{REF} . and we will see in the next section that the IC dims LEDs by regulating the reference voltage.

DIO5662 integrates soft-start to limit the inrush current on the output. And DIO5662 also features internal protection circuits such as over-voltage protection (OVP), cycle-by-cycle current limit protection and thermal shutdown.

DIO5662 adopts PWM dimming control by regulating the reference voltage. The PWM signals through a low-pass filter, then transfer to an analog reference voltage.(PWM to Constant Current Mode). Pin EN listens PWM signals from 200Hz to 200kHz. Once powered on, the DIO5662 gradually soft starts to output LED current proportional to the PWM signal duty cycle. A 100% duty cycle PWM signal leads the IC to maximum current output. And a 0% duty cycle PWM signal or a 2ms long low pulse will shutdown the IC. Any non-0% duty cycle PWM signal to Pin EN will arouse the IC again. Dimming scheme up to 100:1 range.

All the dimming process could be explained in detail that, the output LED current is controlled by the internal feedback voltage V_{FB} , as illustrated in the following Application Notes- LED current Setting Section. And the value of V_{FB} (from 0 to 300mV) is absolutely proportional to the duty cycle of PWM signal (from 0% to 100%). More is depicted in the below figure.

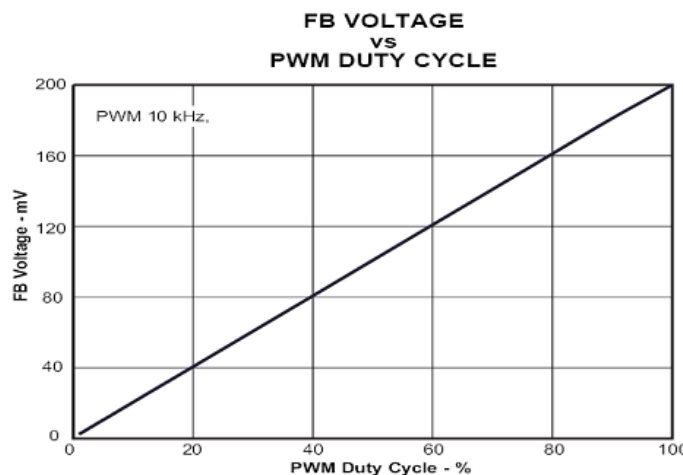

Figure 5. Duty cycle of PWM signal vs. Reference Voltage V_{REF}

Application Notes:

MAX LED Current Settings

LED Current is determined by the current through the feedback resistor R_{FB} , as depicted in the right-hand figure. V_{FB} is a high-impedance state input feedback voltage, so no current goes through Pin FB and the built-in "boost" DC/DC has to pump current to feed I_{FB} .

$$I_{LED} = I_{FB} = V_{FB} / R_{FB}$$

V_{FB} equals to V_{REF} which is internally set to a maximum value of 300mV. So

$$I_{LED(MAX)} = 300mV / R_{FB}$$

For LED current accuracy, 1% precision resistor is recommended.

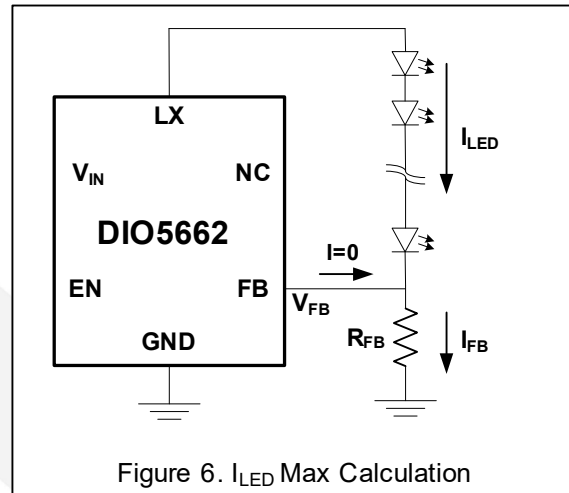

Feedback Voltage V_{FB} Calculation

The feedback voltage V_{FB} is regulated by the internal reference voltage V_{REF} , which is in detail described in Figure 5. So the V_{FB} is approximately same as V_{REF} in the timing, except for that V_{FB} always has a delay with respect to V_{REF} since both in the start-up or the dimming process, the system takes time to adjust V_{FB} equal to V_{REF} . if we neglect these delays, V_{FB} changes with Pin EN signal just as the V_{REF} .

Recommended LED Dimming Method for 10-LEDs series Application

EN pin PWM signal dimming

The principle of PWM dimming control is explained in detail above. A certain duty cycle PWM signal to EN pin will reset the reference voltage V_{REF} , which will in turn determine the LED current. If we set $R_{FB} = 15.0\Omega$, so $I_{LED(MAX)} = 20mA$, then we have I_{LED} changes with the PWM duty cycle as the following:

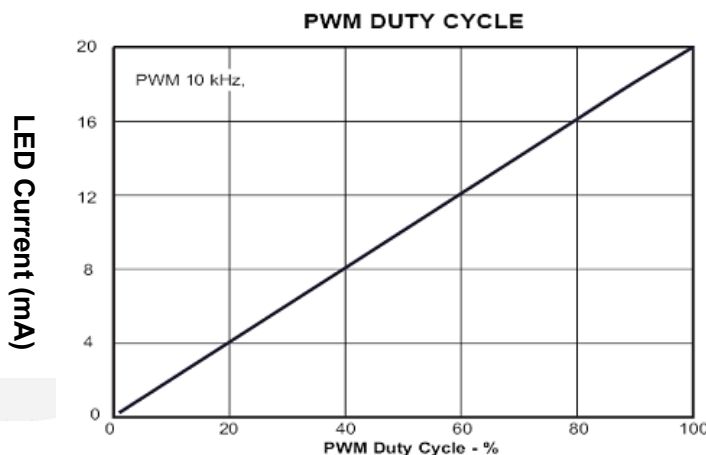

Figure 7. Duty cycle of PWM signal vs. LED Current



DIO5662

37V Step-Up LED Driver with PWM to Constant Current Dimming Mode

Inductor Selection

A 10µH~22µH inductor is recommended for both 10-LED serial string and 3x13 LED matrix application. A low DCR inductor could be suggested if a high efficiency is critical. The inductor's saturation current rating should also exceed the peak input current, especially for high load current application such as 3x13 matrix.

Table 1. Inductor Selector

Part Number	Inductor(µH) @100KHz,1V	DCR(Ω) +/-30%	Min. Self-resonant Frequency(MHz)	Saturation Current(A)	Heat Rating Current(A)
SWPA8040S100MT	10+/-20%	0.029	15	3.60	3.30
SWPA8040S220MT	22+/-20%	0.069	9.5	2.40	2.10

The Calculation Formula of Inductor Peak to Peak (Ipp):

$$I_{PP} = \frac{V_{in} \times D}{L \times F_s}$$

The Calculation Formula of The Cycle Duty:

$$D = \frac{t_{on}}{T_s} = \frac{V_{out} + V_f - V_{in}}{V_{out} + V_f}$$

Vin : The voltage of Input

Ipp : Inductor Peak to Peak

L : The Inductor Value

Vf : The forward bias voltage of Schottky diode

Fs : Switching frequency (1/Ts)

Vout : The voltage of Output

The Calculation Formula of The Inductor Peak current:

$$I_{peak} = I_{in} + \frac{I_{pp}}{2} + \frac{V_{out} * I_{out}}{V_{in} * \eta} + \frac{V_{in} \times D}{2 \times L \times F_s}$$

Capacitor Selection

Small size ceramic capacitors are recommended for DIO5662 application. A 10µF input capacitor and a 0.47µF output capacitor are recommended for 10/8/6-Series LED applications. Larger value output capacitors like 2.2µF are recommended in higher output current applications to minimize output ripple. Ceramic capacitor Vendors such as Murata, AVX, Taiyo Yuden are recommended.

Diode Selection

Since DIO5662's low forward voltage drop and fast reverse recovery time, a schottky diode is recommended. The current rating of the schottky diode should exceed the peak current of the boost converter. The voltage rating should also exceed the target output voltage.



DIO5662

Table 2. Diode Selector

Applications	Schottky Diode Part Number	Forward Voltage/ V	Forward Current mA	Reverse Voltage V	Manufacturer
20mA, 8/10 Serial LEDs 37V OVP	PMEG6010CEJ	0.57	1000	60	NXP

PCB Layout Design Recommendation

As for all switching power supplies, especially those high frequency and high current ones, layout is an important design step. If layout is not carefully done, the regulator could suffer from instability as well as noise problems. To reduce switching losses, the LX pin rise and fall times are made as short as possible. To prevent radiation of high frequency resonance problems, proper layout of the high frequency switching path is essential. Minimize the length and area of all traces connected to the LX pin and always use a ground plane under the switching regulator to minimize inter-plane coupling. The loop including the PWM switch, Schottky diode, and output capacitor, contains high current rising and falling in nanosecond and should be kept as short as possible. The input capacitor needs not only to be close to the V_{IN} pin, but also to the GND pin in order to reduce the IC supply ripple. Figure 8 shows a sample layout.

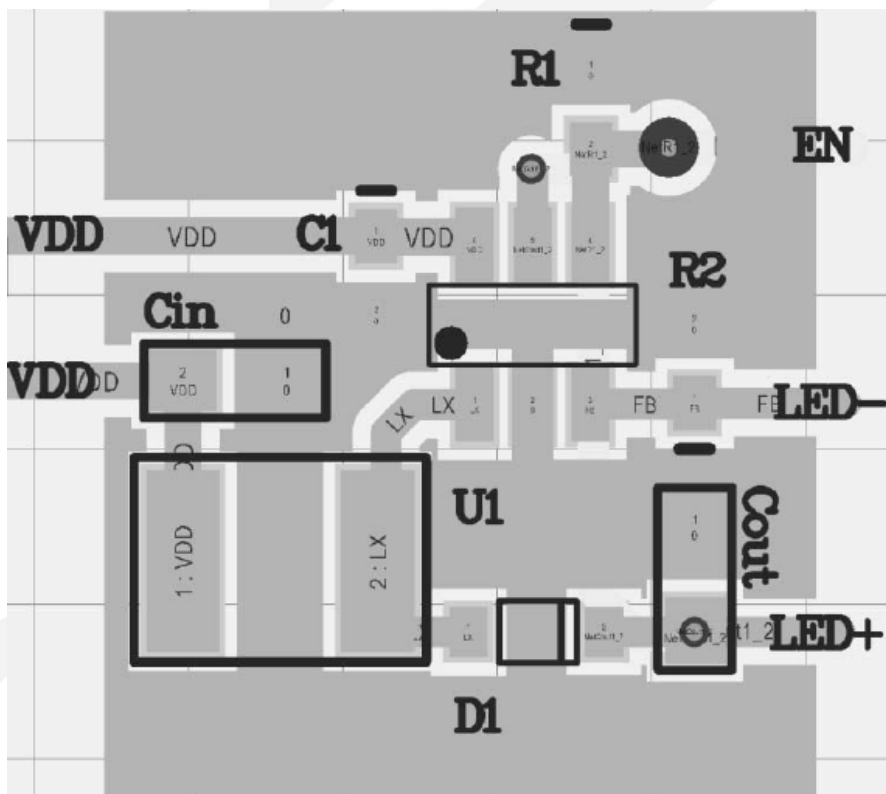

Figure 8. PCB Layout recommended



DIO5662

37V Step-Up LED Driver with PWM to Constant Current Dimming Mode

CONTACT US

Dioo is a professional design and sales corporation for high-quality and performance analog semiconductors. The company focuses on industry markets, such as, cell phone, handheld products, laptop, and medical equipment and so on. Dioo's product families include analog signal processing and amplifying, LED drivers and charger IC. Go to <http://www.dioo.com> for a complete list of Dioo product families.

For additional product information, or full datasheet, please contact with our Sales Department or Representatives.

