



### Description

The MK712 Touch Screen Controller IC provides all the screen drive, A to D converter and control circuits to easily interface to 4-wire analog resistive touch screens.

The IC continually monitors the screen waiting for a touch. In this mode, the supply current is typically 0.5µA. When the screen is touched, the IC performs analog to digital conversions to determine the location of the touch, stores the X and Y locations in the registers, and issues an interrupt. This process is repeated up to 197 times per second until no further screen touches are detected, at which time the low current mode is resumed.

### Block Diagram

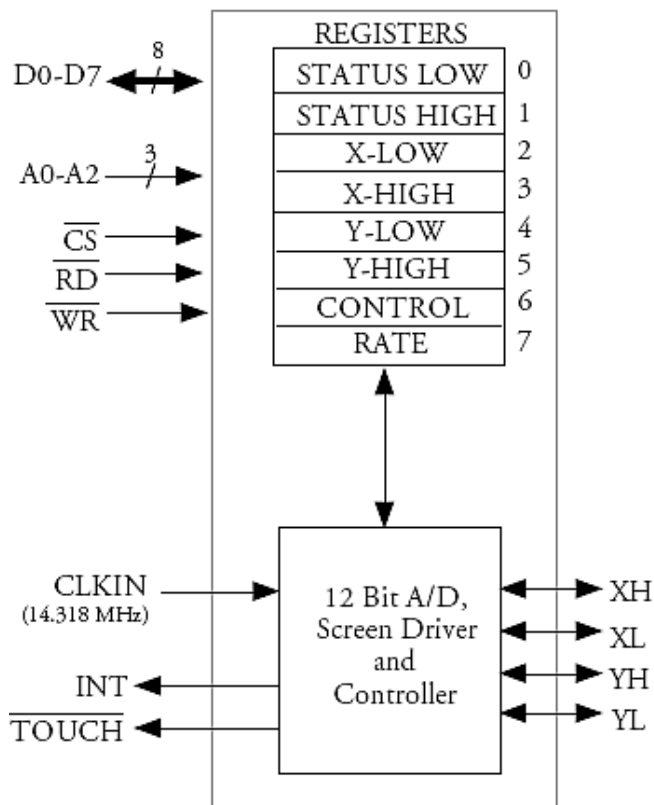

### Features

- Packaged in 28-pin SSOP (150 mil) or 28-pin SOIC (300 mil)
- Industrial (-30°C to +70°C) and commercial (0 to +70°C) and automotive (-35°C to +85°C) temperature ranges
- Available in Pb (lead) free
- Fully integrated, lowest power solution
- Low standby current of 0.5µA (typical) at 5.0 V
- Active current while converting less than 10 mA
- Resolves 350 dots/inch on 10.5" display
- Maximum speed of 197 points/second
- Ratio metric conversion may eliminate screen calibration
- Automatically wakes up and goes back to standby
- 3.3 V or 5 V supply
- 12 bit A/D converter
- Simplifies the writing of software for touch screens
- Extended temperature range available
- Capacitors are the only external components required
- Touch screen is directly driven - no external transistors are required
- Programmable conversion rate
- A to D Converter is monotonic
- Parallel interface
- See the MK715 for a serial interface



## Pin Assignment

NC	<input type="checkbox"/>	1	28	<input type="checkbox"/>	D0
INT	<input type="checkbox"/>	2	27	<input type="checkbox"/>	D1
TOUCH	<input type="checkbox"/>	3	26	<input type="checkbox"/>	D2
VDD	<input type="checkbox"/>	4	25	<input type="checkbox"/>	D3
VDD	<input type="checkbox"/>	5	24	<input type="checkbox"/>	D4
XH	<input type="checkbox"/>	6	23	<input type="checkbox"/>	D5
XL	<input type="checkbox"/>	7	22	<input type="checkbox"/>	VDD
YH	<input type="checkbox"/>	8	21	<input type="checkbox"/>	GND
YL	<input type="checkbox"/>	9	20	<input type="checkbox"/>	D6
GND	<input type="checkbox"/>	10	19	<input type="checkbox"/>	D7
GND	<input type="checkbox"/>	11	18	<input type="checkbox"/>	CLKIN
$\overline{WR}$	<input type="checkbox"/>	12	17	<input type="checkbox"/>	A0
$\overline{RD}$	<input type="checkbox"/>	13	16	<input type="checkbox"/>	A1
$\overline{CS}$	<input type="checkbox"/>	14	15	<input type="checkbox"/>	A2

## Pin Descriptions

Pin Number	Pin Name	Pin Type	Pin Description
1	NC	—	No connect. Do not connect this pin to anything.
2	INT	Output	Interrupt. Goes high to signal an interrupt. Cleared on next read.
3	TOUCH	Output	Touch signal. Goes low when screen is touched. Goes high when not touched.
4	VDD	Power	Power Supply. Connect to +5 V or +3.3 V. (Connect all VDDs to same voltage)
5	VDD	Power	Power Supply. Connect to +3.3 V.
6	XH	Touch Screen Pin	Connect to X-high on touch screen. (Right side)
7	XL	Touch Screen Pin	Connect to X-low on touch screen. (Left side)
8	YH	Touch Screen Pin	Connect to Y-high on touch screen. (Top)
9	YL	Touch Screen Pin	Connect to Y-low on touch screen. (Bottom)
10	GND	Power	Connect to ground.
11	GND	Power	Connect to ground.
12	$\overline{WR}$	Input	Write enable. Active low.
13	$\overline{RD}$	Input	Read enable. Active low.
14	$\overline{CS}$	Input	Chip select. Active low.
15	A2	Input	Register address 2.
16	A1	Input	Register address 1.
17	A0	Input	Register address 0.
18	CLKIN	Input	Clock input. Typically 14.3 MHz. Best if driven by an ICS clock synthesizer.
19	D7	I/O	Data bit 7.
20	D6	I/O	Data bit 6.
21	GND	Power	Connect to ground.
22	VDD	Power	Power Supply. Connect to +5 V or +3.3 V. (Connect all VDDs to same voltage)
23	D5	I/O	Data bit 5.
24	D4	I/O	Data bit 4.
25	D3	I/O	Data bit 3.
26	D2	I/O	Data bit 2.
27	D1	I/O	Data bit 1.
28	D0	I/O	Data bit 0.



## Interrupts

Interrupts are controlled by register 6 (see Register Description). The INT pin (pin 2) goes high to signal an interrupt. Interrupts are then cleared by reading any register. However, if the MK712 is in the process of generating an interrupt during a read cycle, then the interrupt is not cleared and INT will stay high. This internal process may take 100ns, and so to guarantee that the interrupt is cleared, two successive read cycles may be necessary.



### IC Operation

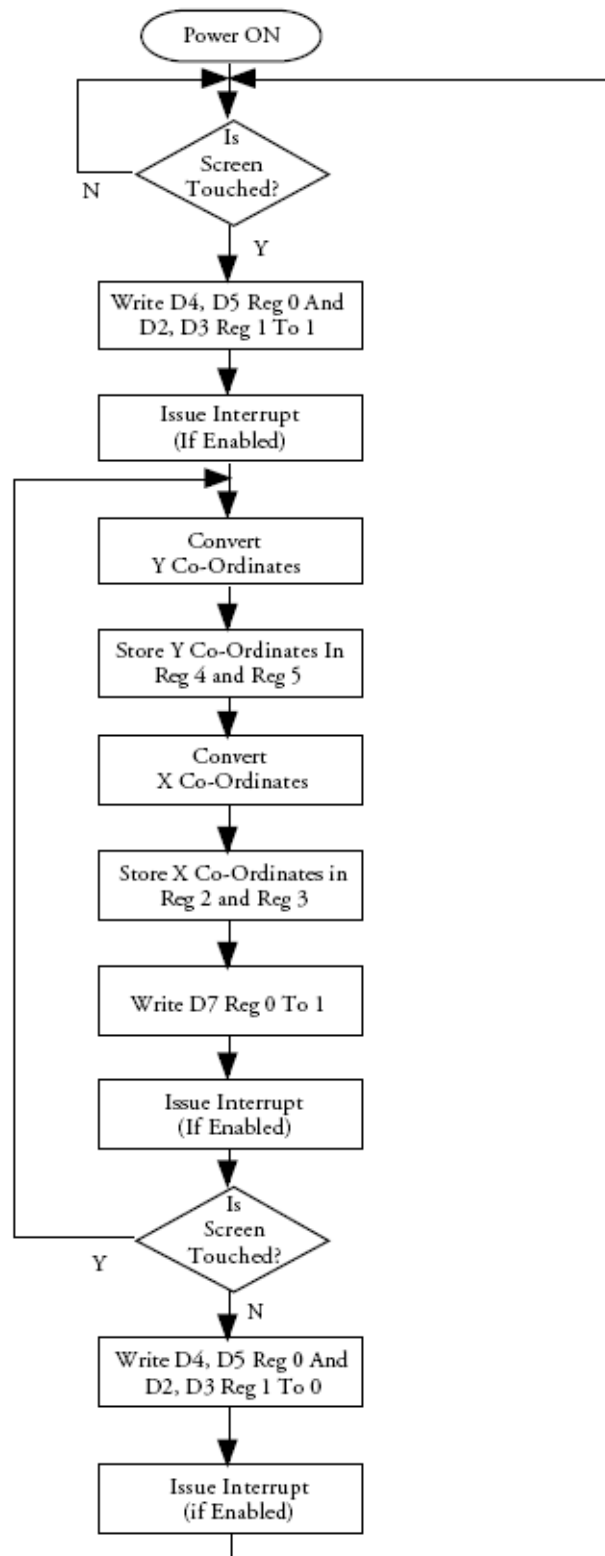



### Register Description

The MK712 register set is designed to be compatible with the Gazelle pen digitizer registers allowing a software driver for the Gazelle digitizer to be used with the MicroClock MK712. The eight 8-bit registers are defined below:

#### STATUS LOW (0 READ)

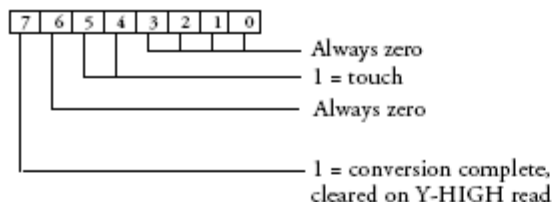

NOTE: When the screen is touched bits 4 and 5, register 0, and bits 2 and 3 of register 1 are all set to one.

#### STATUS HIGH (1 READ)

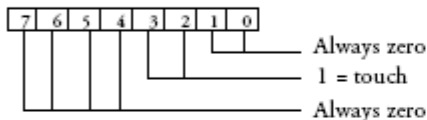

#### X-LOW (2 READ)

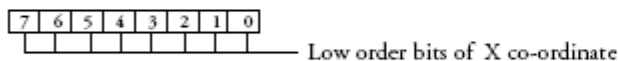

#### X-HIGH (3 READ)

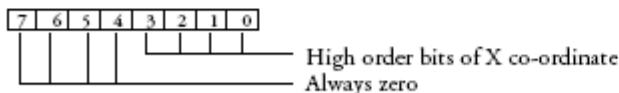

#### Y-LOW (4 READ)



#### Y-HIGH (5 READ)



#### CONTROL (6 R/W)

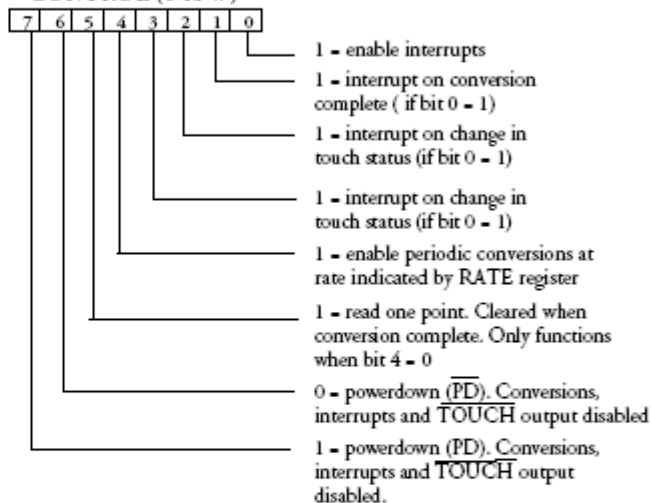

NOTE: Bits 2 or 3 and bits 6 or 7 are logically OR'd. For example writing bit 2 or bit 3 to a one will enable interrupts on change in touch status.

#### RATE (7 R/W)

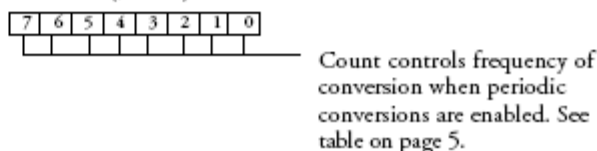



### Rate Register (Register 7) Programming

Count	P.P.S.	Count	P.P.S.	Count	P.P.S.
0 to 8	Not Permitted	28	95	100	32
9	197	29	93	105	31
10	187	30	90	110	29
11	177	31	88	115	28
12	169	32	86	120	27
13	161	33	84	125	26
14	154	34	82	130	25
15	147	35	80	135	24
16	141	40	72	140	24
17	136	45	65	145	23
18	131	50	60	150	22
19	126	55	55	155	21
20	122	60	51	165	20
21	118	65	47	175	19
22	114	70	44	185	18
23	110	75	42	195	17
24	107	80	39	205	16
25	104	85	37	225	15
26	101	90	35	235	14
27	98	95	34	255	13

P.P.S. = Points Per Second. With a 14.318 MHz clock.

### Calculating Points Per Second

The formula for determining P.P.S. is:

$$P.P.S. = \frac{f_{in}}{35716 + (4096 \times COUNT)}$$

Where  $f_{in}$  is the frequency of the CLKIN input.

### Power-On Reset

On application of power, an internal reset is generated that clears all bits in registers 0, 1, and 6. Register 7 is set to 32 giving a rate of 86 PPS. Note that clearing register 6 puts the IC into the power down condition.

### Initializing the MK712

The interrupt on the MK712 can only be cleared by reading a register or by writing register 6 to the power down condition. After a fault condition, initialize the MK712 by writing register 6 to zero and then writing register 6 to the desired value. This will always clear pending interrupts.



### Recommended Circuit

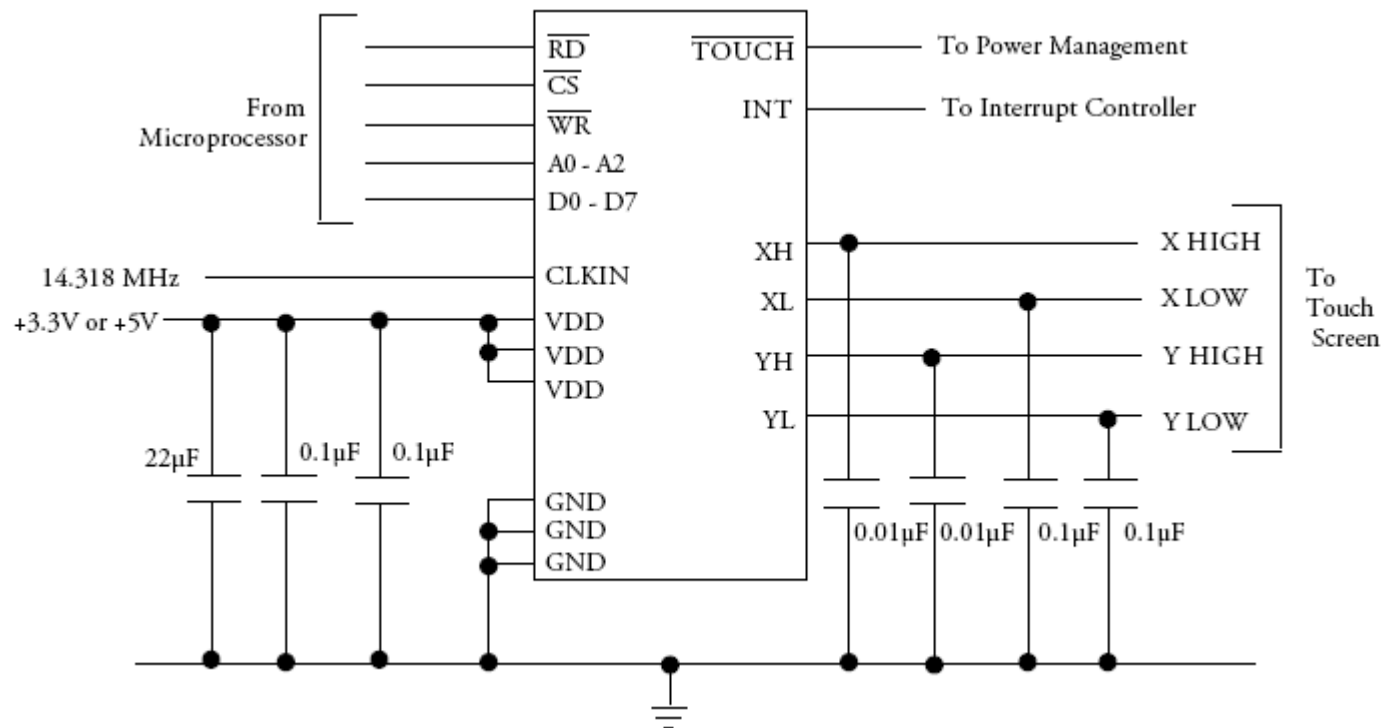

### Pen Bounce

When the screen is untouched, the Y plate is driven high and the X plate is driven low. When the screen is touched, the X plate is pulled high, which is detected by the MK712. This initiates a conversion (as long as periodic conversions are enabled). Some de-bounce is provided by the time constant of the screen decoupling capacitors combined with the screen resistance. However, once conversions have started, pen bounce will not be detected until after both the X and Y points have been taken.

If the pen is lifted during a conversion, this will also not be detected until the conversion is complete. This is typically indicated by a point with the correct Y coordinates, but minimum (for that screen) X coordinates.

### Screen Decoupling

The component values suggested should give excellent results. However, for screens with a high resistance operating at a high conversion rate, extra interrupts may be issued. This is because the time constant of the screen decoupling capacitors and screen resistance is high, resulting in the screen appearing to be untouched and then touched between conversions. These extra interrupts can be eliminated by reducing the size of the screen decoupling capacitors on pins XH, XL, YH, and YL. This will, however, slightly reduce the noise rejection, which could decrease the accuracy of the conversion.

## Optimizing Performance when Reading and Writing Registers

Reading and writing the MK712 generates digital noise that may reduce the accuracy of the A to D converter. This noise has several causes, including board layout, data bus loading, and power supply voltage. By appropriately timing the register operations, the effects of this noise can be minimized.

After an interrupt is issued, the MK712 allows a minimum of 1 millisecond to elapse before initiating the conversion cycle. This allows the screen drivers to settle. For best performance, complete all register operations within this 1ms window after an interrupt.

## Power Down/Stopping the Clock

If the screen is untouched, the supply current is under  $3\mu\text{A}$ . If the input clock is stopped, the supply current is also less than  $3\mu\text{A}$ . When the screen is touched with no clock,  $\overline{\text{TOUCH}}$  goes low and INT goes high, but no further operations occur until the clock starts. A to D conversions are invalid until after the clock has stabilized at the correct frequency and one full conversion cycle has been completed.

## Input Clock

The MK712 is highly tolerant of different clock frequencies (from 12 to 20 MHz), rise times, and duty cycles. However, any input clock undershoot or overshoot will cause the MK712 to draw extra current. This can be eliminated by using a MicroClock clock synthesizer and properly terminating the clock driver. MicroClock makes low power clock synthesizers with 14.3 MHz power down.

## Resistive Touch Screen (4-wire)

Resistive touch screens consist of 2 resistive plates that are separated by a small gap. Each plate has an electrode at each end and when the screen is touched, the two plates are shorted together at that point.

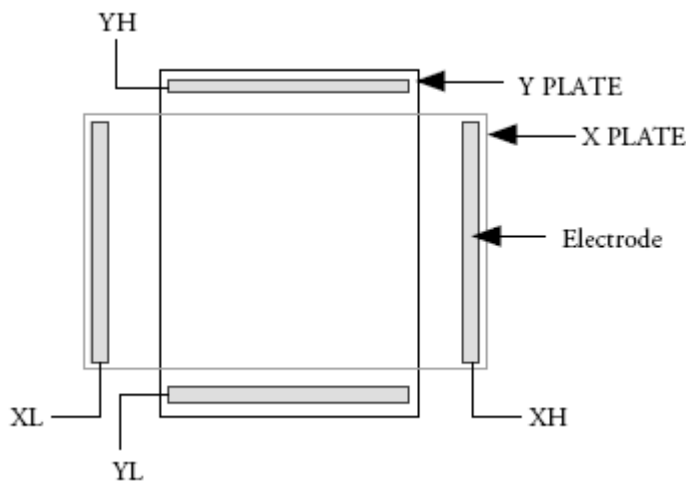

If a voltage is applied, for example, between XL and XH, then a voltage divider is formed on the X PLATE. When the Y PLATE is touched to the X PLATE, a voltage will be developed on the Y PLATE that is proportional to distance of the touch from XL and XH. By accurately measuring this voltage, the position of the touch can be determined.

## Recommended Method for Reading Points

If the user is pressing lightly on the touch screen, it is likely that the screen contact will be intermittent. The screen will bounce, causing false points. This effect can be reduced by insuring that the screen is touched both before and after a conversion. By doing this, the first and last point in a series of points are discarded. The following algorithm checks that a point has valid touches both before and after a conversion, and it distinguishes between change-in-touch interrupts and conversion complete interrupts. Register 6 bits 0, 1, and 2 must all be true (logical 1) in order to use this method.

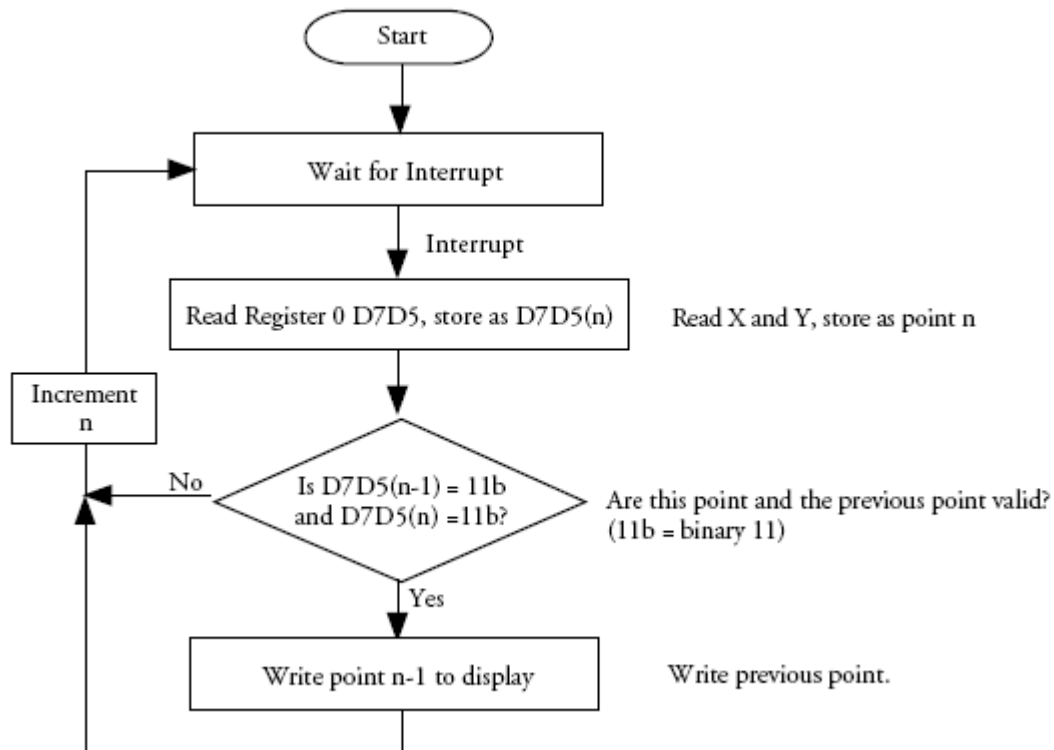

## Warning—When Using a Switching Regulator Power Supply

When using the MK712 in a system where the power is supplied by a switching regulator, do not perform screen conversions when the regulator is operating in the power saving mode. Some switching regulators feature a low power mode (for example, Linear Technology’s “Burst Mode”) where the output is turned on and off in order to save power. The extra power supply noise generated when using this mode causes spurious data points to be returned from the MK712, so it should be disabled when the MK712 is doing screen conversions.

## Analog to Digital Converter Option

The 12-bit ADC converts X and Y co-ordinates at a rate determined by registers 6 and 7. The converter uses a ratiometric technique to give absolute co-ordinates on the screen, largely independent of variations in screen resistance, temperature or power supply voltage. The total voltage applied across the screen is defined as full-scale for the converter (i.e. 4095) and any point touched on the screen is proportional to this. For example, if the screen is touched exactly in the center, the converter will read 2047. This feature may allow for the elimination of calibration upon startup.

However, the full scale voltage is defined at the IC pins and so any parasitic interconnect resistance will be included in full scale. In addition, the interconnect resistances on the screen also account for about 20% of the total resistance. This means that approximately the bottom 10% and top 10% of full scale are inaccessible.

The converter is guaranteed to be monotonic, with no missing codes.

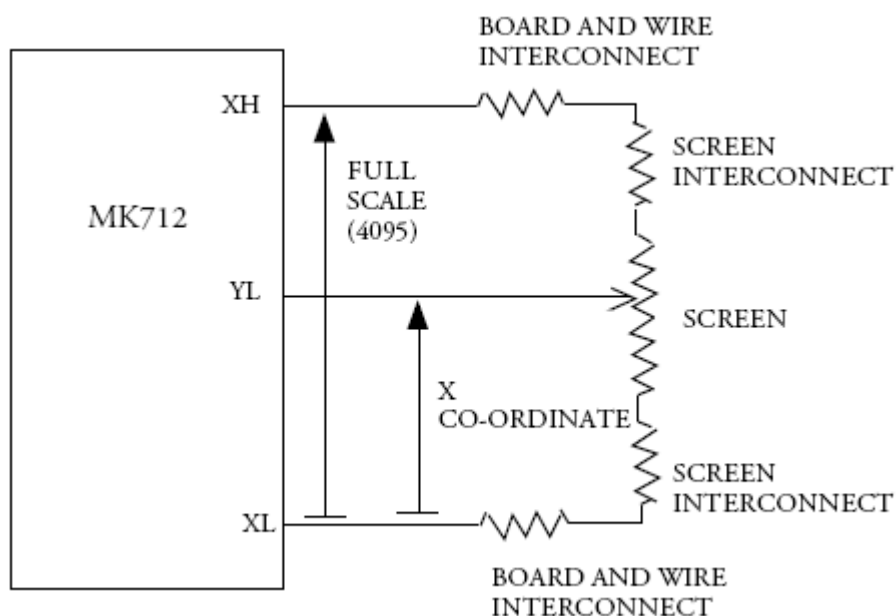



## Absolute Maximum Ratings

Stresses above the ratings listed below can cause permanent damage to the MK712. These ratings, which are standard values for ICS commercially rated parts, are stress ratings only. Functional operation of the device at these or any other conditions above those indicated in the operational sections of the specifications is not implied. Exposure to absolute maximum rating conditions for extended periods can affect product reliability. Electrical parameters are guaranteed only over the recommended operating temperature range.

Item	Rating
Supply Voltage, VDD (referenced to ground)	7 V
All Inputs and Outputs (referenced to ground)	-0.5 V to VDD+0.5 V
Ambient Operating Temperature (commercial)	0 to +70°C
Ambient Operating Temperature (industrial)	-30 to +70°C
Ambient Operating Temperature (automotive)	-35 to +85°C
Storage Temperature	-65 to +150°C
Junction Temperature	125°C
Soldering Temperature (10 to 20 seconds max)	260°C

## Recommended Operation Conditions

Parameter	Min.	Typ.	Max.	Units
Ambient Operating Temperature (commercial)	0		+70	°C
Ambient Operating Temperature (industrial)	-30		+70	°C
Ambient Operating Temperature (automotive)	-35		+85	°C
Power Supply Voltage (measured in respect to GND) (commercial and industrial)	+3.0		+5.5	V
Power Supply Voltage (measured in respect to GND) (automotive)	+3.135		+5.5	V



## DC Electrical Characteristics

Unless stated otherwise,  $V_{DD} = 3.3\text{ V}$  or  $5\text{ V}$ ,  $T_A = 0$  to  $+70^\circ\text{C}$  (commercial),  $-30^\circ\text{C}$  to  $+70^\circ\text{C}$  (industrial),  $-35^\circ\text{C}$  to  $+85^\circ\text{C}$  (automotive)

Parameter	Symbol	Conditions	Min.	Typ.	Max.	Units
Operating Voltage	VDD	Commercial and industrial	3.0		5.5	V
Operating Voltage	VDD	Automotive	3.135		5.5	V
Input High Voltage	$V_{IH}$	VDD=5 V	2			V
Input Low Voltage	$V_{IL}$	VDD=5 V			0.8	V
Output High Voltage	$V_{OH}$	$I_{OH} = -2\text{ mA}$	VDD-0.4			V
Output High Voltage	$V_{OH}$	VDD=5 V, $I_{OH} = -12\text{ mA}$	2.4			V
Output Low Voltage	$V_{OL}$	VDD=5 V, $I_{OL} = 12\text{ mA}$			0.4	V
Input High Voltage	$V_{IH}$	VDD=3.3 V	1.9			V
Input Low Voltage	$V_{IL}$	VDD=3.3 V			0.4	V
Output High Voltage	$V_{OH}$	VDD=3.3 V, $I_{OH} = -8\text{ mA}$	2.4			V
Output Low Voltage	$V_{OL}$	VDD=3.3 V, $I_{OL} = 8\text{ mA}$			0.4	V
Operating Supply Current	IDD	At VDD=5 V, 300 $\Omega$ screen, 100 PPS		5		mA
		At VDD=3.3 V, Note 3		3		mA
		Standby, Clock, Note 4		0.5	3	$\mu\text{A}$
		Standby, Note 5		0.5	3	$\mu\text{A}$
		Power down, $\overline{PD}=0$ or $\overline{PD}=1$ , no clock		0.2	3	$\mu\text{A}$
Short Circuit Current	$I_{OS}$	Each output		$\pm 50$		mA
Input Capacitance	$C_{IN}$			7		pF



## AC Electrical Characteristics

Unless stated otherwise,  $V_{DD} = 3.3\text{ V}$  or  $5\text{ V}$ ,  $T_A = 0$  to  $+70^\circ\text{C}$  (commercial),  $-30^\circ\text{C}$  to  $+70^\circ\text{C}$  (industrial),  $-35^\circ\text{C}$  to  $+85^\circ\text{C}$  (automotive)

Parameter	Symbol	Conditions	Min.	Typ.	Max.	Units
Input Clock Frequency, pin 18		Note 1	12	14.32	20	MHz
Input Clock Duty Cycle, pin 18		At 1.5 V	25		75	%
Output Rise Time	$t_{OR}$	0.8 to 2.0 V, $V_{DD}=5\text{ V}$			3	ns
Output Fall Time	$t_{OF}$	2.0 to 0.8 V, $V_{DD}=5\text{ V}$			3	ns
Resolution					12	bits
Non-linearity		Monotonic, Note 2			$\pm 2$	LSB
Touch Screen Resistance			100		2000	$\Omega$

Note 1: Consult with ICS about the best device to use to generate the input clock.

Note 2: With no missing codes.

Note 3: Assumes no 14.3 MHz input clock overshoot,  $300\Omega$  screen, 100 PPS.

Note 4: Assumes no 14.3 MHz input clock overshoot, no touch.

Note 5: With no touch, no clock.



## Register Interface Timing

Number	Symbol	Description	Min.	Max.	Units	Note
<b>Read and Write Cycles</b>						
1	TRASC	Address Setup to $\overline{CS}$ Low	5		ns	
2	TRAHC	Address Hold from $\overline{CS}$ High	0		ns	
3	TRCCY	$\overline{CS}$ High to $\overline{CS}$ Low	40		ns	
<b>Read Cycle Only</b>						
4	TRSCR	$\overline{CS}$ Low to $\overline{RD}$ Low	10		ns	
5	TRRD	$\overline{RD}$ Pulse Width	40		ns	
6	TRCHR1	$\overline{RD}$ High to $\overline{CS}$ High	0		ns	
7	TRCHR2	$\overline{RD}$ High to $\overline{CS}$ Low	40		ns	
8	TRDC	$\overline{CS}$ Low to Data		35	ns	
9	TRDR	$\overline{RD}$ Low to Data		35	ns	
10	TRDHC	$\overline{CS}$ High to Data Release	2	20	ns	1
11	TRDHR	$\overline{RD}$ High to Data Release	2	20	ns	1
<b>Write Cycle Only</b>						
12	TRCSW	$\overline{CS}$ Low to $\overline{WR}$ Low	10		ns	
13	TRWR	$\overline{WR}$ Pulse Width	40		ns	
14	TRCHW	$\overline{WR}$ High to $\overline{CS}$ High	0		ns	2
15	TRWH	$\overline{WR}$ High to $\overline{CS}$ Low	40		ns	
16	TRWCY	$\overline{WR}$ High to $\overline{WR}$ Low	40		ns	
17	TRDW	Data Setup to $\overline{WR}$ High	15		ns	3
18	TRDHW	Data Hold from $\overline{WR}$ High	15		ns	4
19	TRDWC	Data Setup to $\overline{CS}$ High	15		ns	3
20	TRDHC	Data Hold from $\overline{CS}$ High	15		ns	4

### Notes:

1.  $\overline{RD}$  edges may precede or follow  $\overline{CS}$  edges.
2.  $\overline{WR}$  edges may precede or follow  $\overline{CS}$  edges.
3. Either TRDW or TRDWC specification must be met.
4. Either TRDHW or TRDHC specification must be met.
5. It is not permitted to have both  $\overline{RD}$  and  $\overline{WR}$  low at the same time.



### Register Read

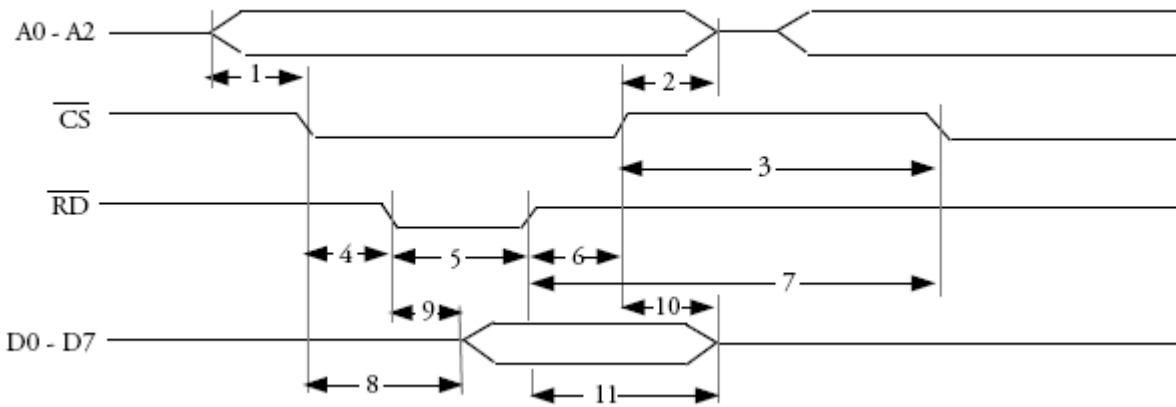

### Register Write

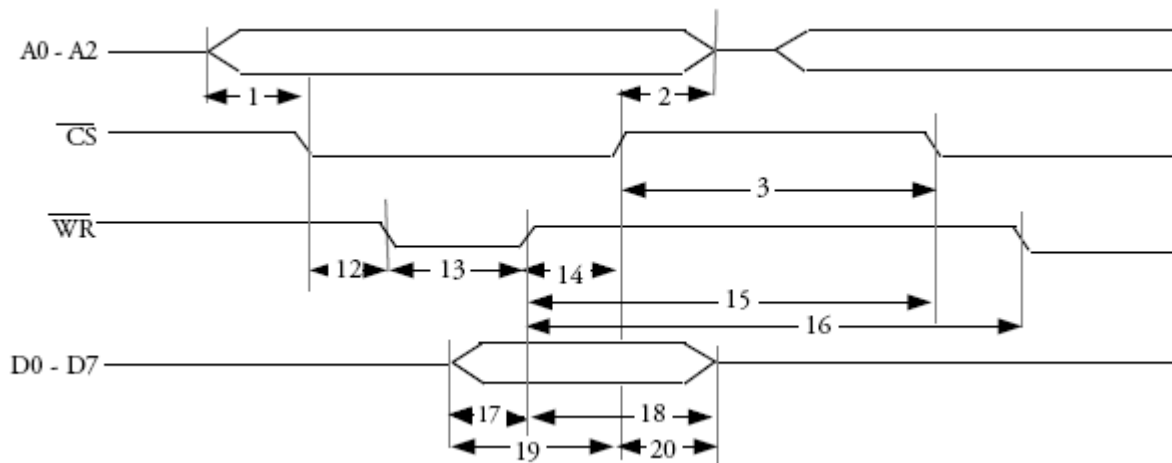



### Touchscreen Resistance Graph 1

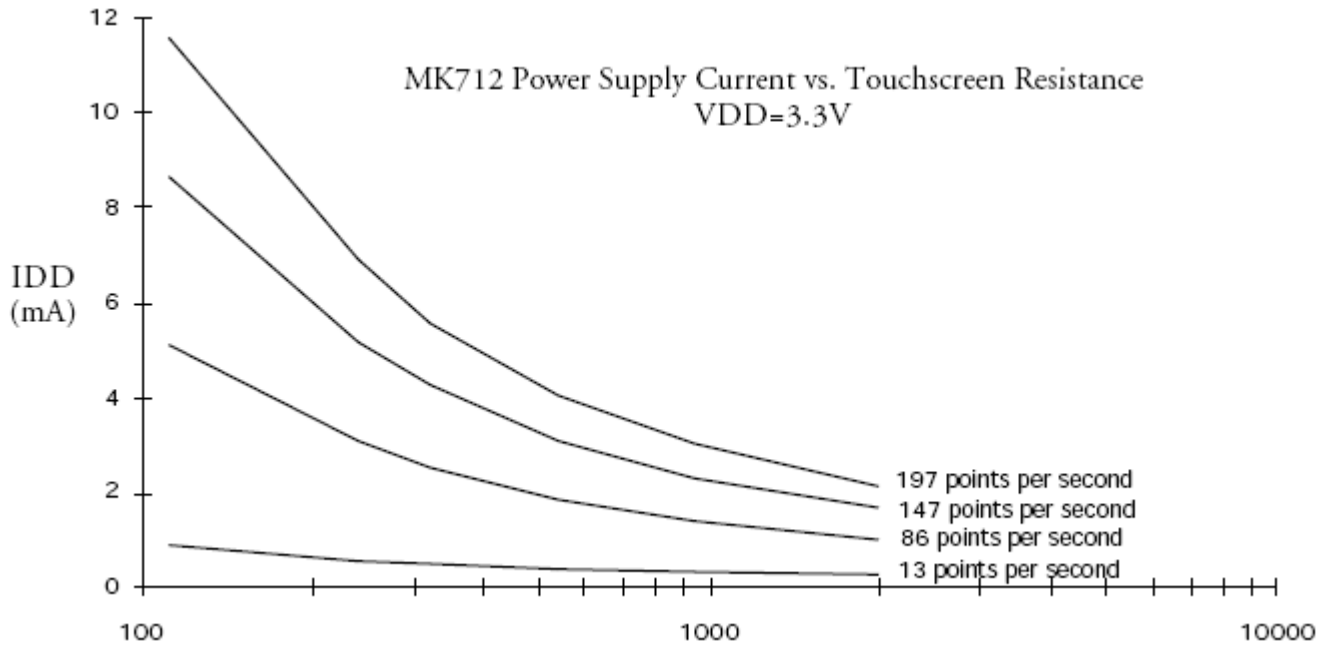

### Touchscreen Resistance Graph 2

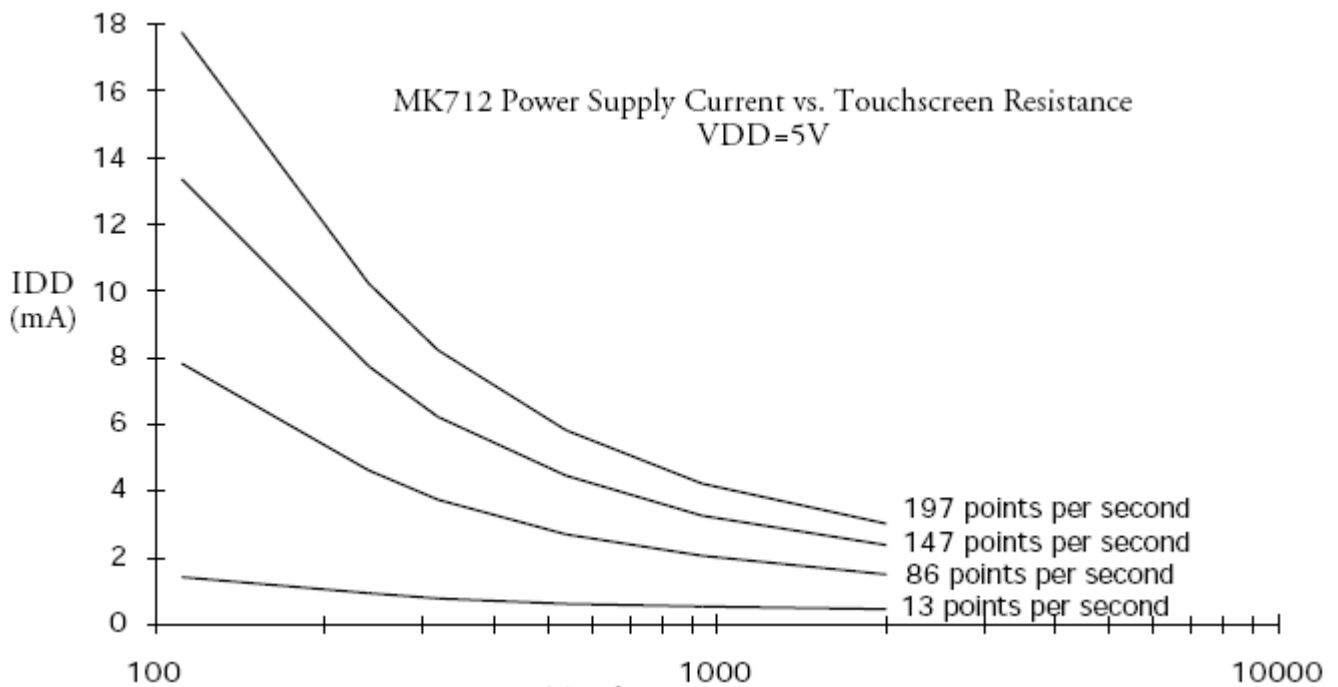



### Touchscreen Resistance Graph 3

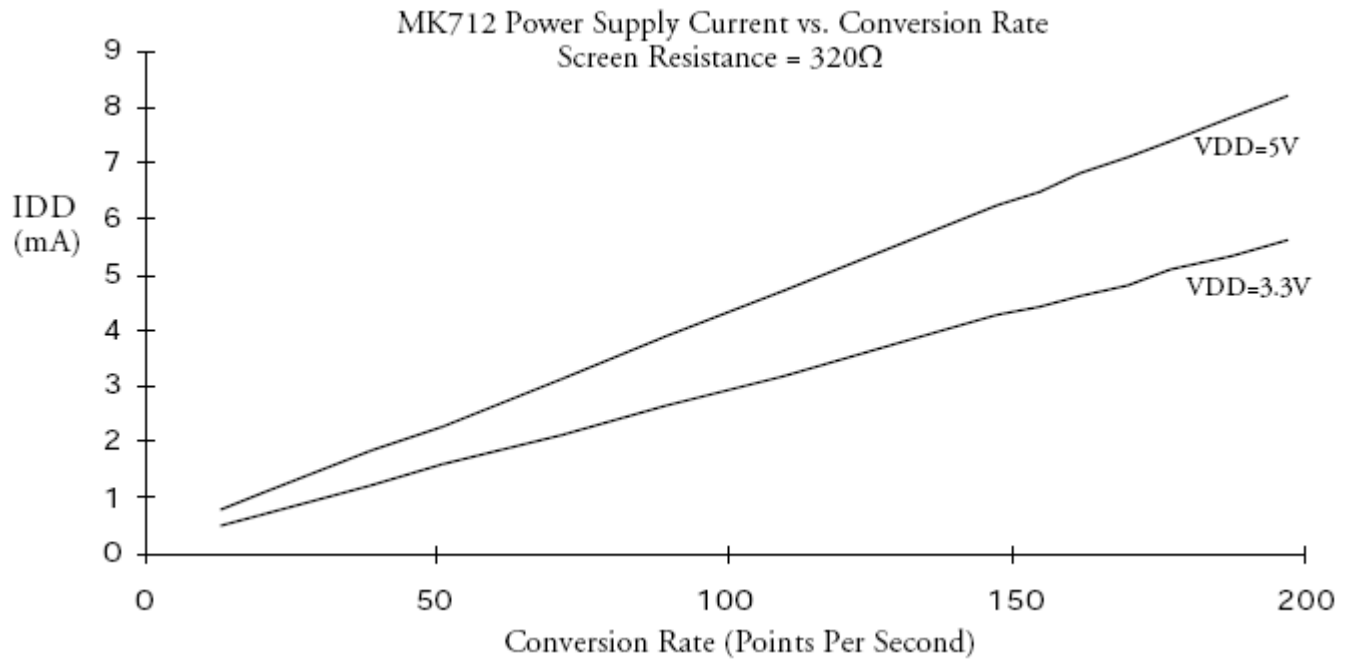



## Suggested Layout

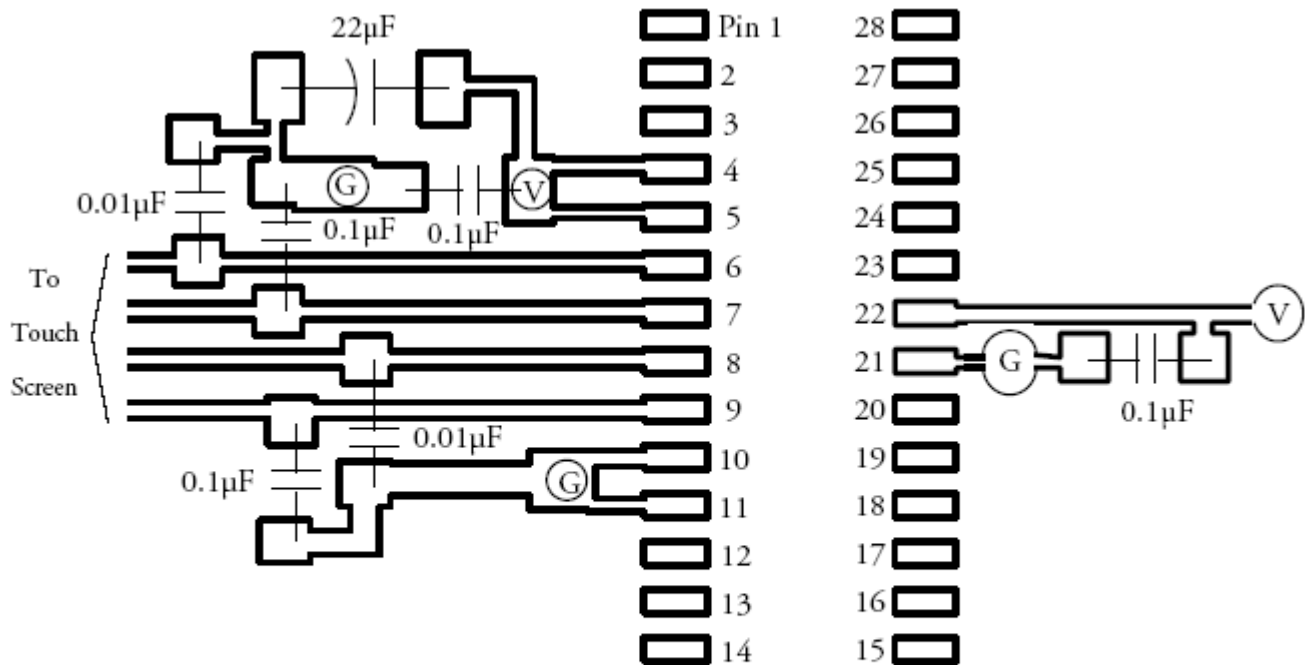

Ⓞ = connection to ground plane

Ⓟ = connection to VDD plane

### Notes:

1. The 14.318 MHz input clock on pin 18 should have a  $33\Omega$  series termination resistor at its source. Consult ICS for the best way to generate this clock.
2. All digital signals should be kept well away from pins 4, 5, 6, 7, 8, 9, 10, and 11, and any traces connected to those pins.



### Package Outline and Package Dimensions (28-pin SOIC, 300 Mil. Wide Body)

Package dimensions are kept current with JEDEC Publication No. 95

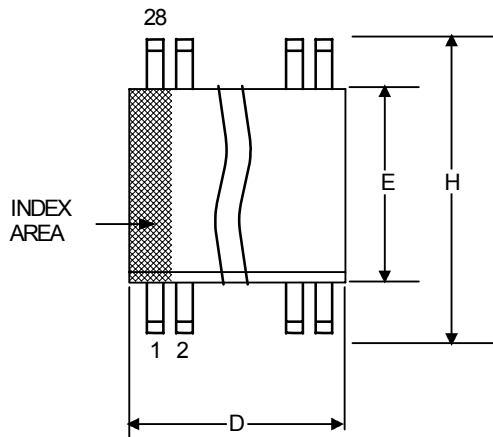

Symbol	Millimeters		Inches	
	Min	Max	Min	Max
A	—	2.65	—	0.104
A1	0.10	—	0.004	0.010
A2	--	1.50	0.0040	—
B	0.33	0.51	0.013	0.020
C	0.18	0.32	0.007	0.013
D	17.70	18.40	0.697	0.724
E	7.40	7.60	0.291	0.299
e	1.27 Basic		.050 Basic	
H	10.00	10.65	0.394	0.419
h	0.25	0.75	0.010	0.029
L	0.40	1.27	0.016	0.050
$\alpha$	0°	8°	0°	8°

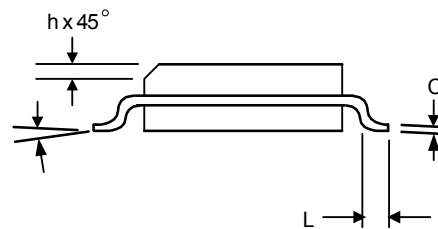
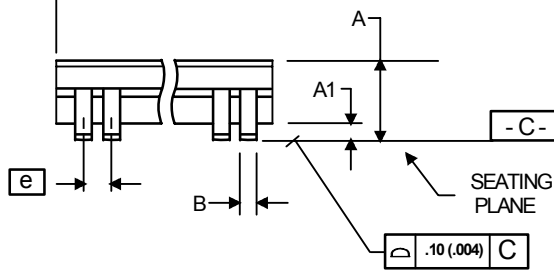



### Package Outline and Package Dimensions (28-pin SSOP, 150 Mil. Wide Body)

Package dimensions are kept current with JEDEC Publication No. 95

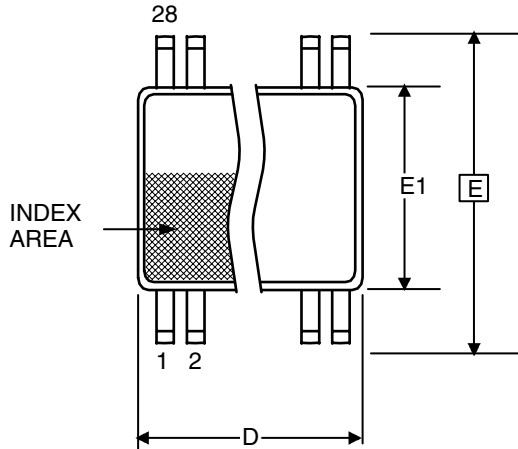

Symbol	Millimeters		Inches	
	Min	Max	Min	Max
A	1.35	1.75	0.053	0.069
A1	0.10	0.25	0.004	0.010
A2	--	1.50	--	.059
b	0.20	0.30	0.008	0.012
C	0.18	0.25	0.007	0.010
D	9.80	10.00	0.386	0.394
E	5.80	6.20	0.228	0.244
E1	3.80	4.00	0.150	0.157
e	.635 Basic		.025 Basic	
L	0.40	1.27	0.016	0.050
$\alpha$	0°	8°	0°	8°

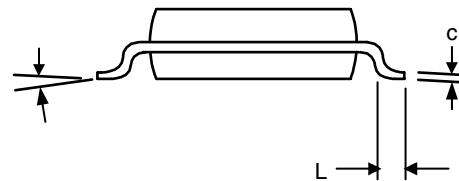
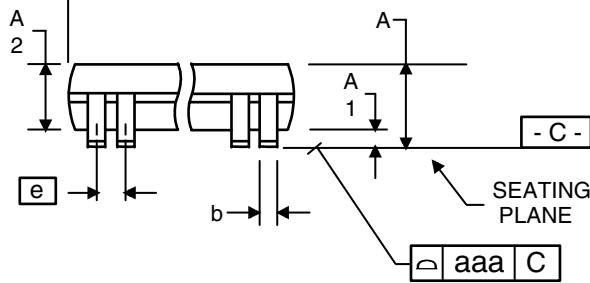



## Ordering Information

Part / Order Number	Marking	Shipping Packaging	Package	Temperature
MK712S	MK712S	Tubes	28-pin SOIC	0 to +70° C
MK712STR	MK712S	Tape and Reel	28-pin SOIC	0 to +70° C
MK712SI	MK712SI	Tubes	28-pin SOIC	-30 to +70° C
MK712SITR	MK712SI	Tape and Reel	28-pin SOIC	-30 to +70° C
MK712R	MK712R	Tubes	28-pin SSOP	0 to +70° C
MK712RTR	MK712R	Tape and Reel	28-pin SSOP	0 to +70° C
MK712RLF	MK712RLF	Tubes	28-pin SSOP	0 to +70° C
MK712RLFTR	MK712RLF	Tape and Reel	28-pin SSOP	0 to +70° C
MK712RI	MK712RI	Tubes	28-pin SSOP	-30 to +70° C
MK712RITR	MK712RI	Tape and Reel	28-pin SSOP	-30 to +70° C
MK712RWLF	MK712RWLF	Tubes	28-pin SSOP	-35 to +85° C
MK712RWLFTR	MK712RWLF	Tape and Reel	28-pin SSOP	-35 to +85° C

**Parts that are ordered with a “LF” suffix to the part number are the Pb-Free configuration and are RoHS compliant.**

While the information presented herein has been checked for both accuracy and reliability, Integrated Circuit Systems (ICS) assumes no responsibility for either its use or for the infringement of any patents or other rights of third parties, which would result from its use. No other circuits, patents, or licenses are implied. This product is intended for use in normal commercial applications. Any other applications such as those requiring extended temperature range, high reliability, or other extraordinary environmental requirements are not recommended without additional processing by ICS. ICS reserves the right to change any circuitry or specifications without notice. ICS does not authorize or warrant any ICS product for use in life support devices or critical medical instruments.