

December 1992

CMOS 8-Stage Static Shift Registers

Features

- High Voltage Types (20V Rating)
- Medium Speed Operation 12MHz (Typ.) Clock Rate at VDD-VSS = 10V
- Fully Static Operation
- 8 Master-Slave Flip-Flops Plus Output Buffering and Control Gating
- 100% Tested for Quiescent Current at 20V
- Maximum Input Current of 1 μ A at 18V Over Full Package Temperature Range; 100nA at 18V and +25 $^{\circ}$ C
- Noise Margin (Full Package Temperature Range)
- 1V at VDD = 5V
- 2V at VDD = 10V
- 2.5V at VDD = 15V
- Standardized Symmetrical Output Characteristics
- 5V, 10V and 15V Parametric Ratings
- Meets All Requirements of JEDEC Tentative Standard No. 13B, "Standard Specifications for Description of 'B' Series CMOS Devices

Applications:

- Parallel Input/Serial Output Data Queuing
- Parallel to Serial Data Conversion
- General Purpose Register

Description

CD4014BMS -Synchronous Parallel or Serial Input/Serial Output

CD4021BMS -Asynchronous Parallel Input or Synchronous Serial Input/Serial Output

CD4014BMS and CD4021BMS series types are 8-stage parallel- or serial-input/serial output registers having common CLOCK and PARALLEL/SERIAL CONTROL inputs, a single SERIAL data input, and individual parallel "JAM" inputs to each register stage. Each register stage is a D-type, master-slave flip-flop. In addition to an output from stage 8, "Q" outputs are also available from stages 6 and 7. Parallel as well as serial entry is made into the register synchronously with the positive clock line transition in the CD4014BMS. In the CD4021BMS serial entry is synchronous with the clock but parallel entry is asynchronous. In both types, entry is controlled by the PARALLEL/SERIAL CONTROL input. When the PARALLEL/SERIAL CONTROL input is low, data is serially shifted into the 8-stage register synchronously with the positive transition of the clock line. When the PARALLEL/SERIAL CONTROL input is high, data is jammed into the 8-stage register via the parallel input lines and synchronous with the positive transition of the clock line. In the CD4021BMS, the CLOCK input of the internal stage is "forced" when asynchronous parallel entry is made. Register expansion using multiple packages is permitted.

The CD4014BMS and CD4021BMS are supplied in these 16 lead outline packages:

Braze Seal DIP	H4T
Frit Seal DIP	H1F
Ceramic Flatpack	H6W

Pinout

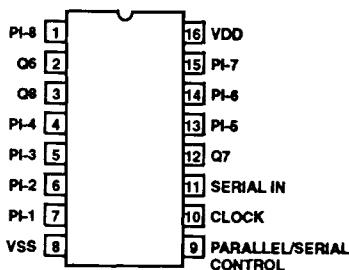

Functional Diagram

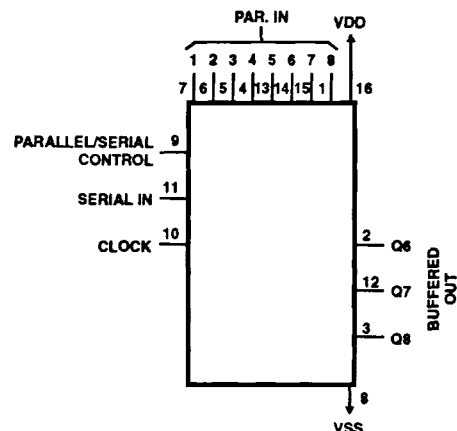

Specifications CD4014BMS, CD4021BMS

Absolute Maximum Ratings

DC Supply Voltage Range, (VDD) -0.5V to +20V
 (Voltage Referenced to VSS Terminals)
 Input Voltage Range, All Inputs -0.5V to VDD +0.5V
 DC Input Current, Any One Input ±10mA
 Operating Temperature Range -55°C to +125°C
 Package Types D, F, K, H
 Storage Temperature Range (TSTG) -65°C to +150°C
 Lead Temperature (During Soldering) +265°C
 At Distance 1/16 ± 1/32 Inch (1.59mm ± 0.79mm) from case for
 10s Maximum

Reliability Information

Thermal Resistance θ_{JA} θ_{JC}
 Ceramic DIP and FRIT Package 80°C/W 20°C/W
 Flatpack Package 70°C/W 20°C/W
 Maximum Package Power Dissipation (PD) at +125°C
 For TA = -55°C to +100°C (Package Type D, F, K) 500mW
 For TA = +100°C to +125°C (Package Type D, F, K) Derate
 Linearity at 12mW/°C to 200mW
 Device Dissipation per Output Transistor 100mW
 For TA = Full Package Temperature Range (All Package Types)
 Junction Temperature +175°C

TABLE 1. DC ELECTRICAL PERFORMANCE CHARACTERISTICS

PARAMETER	SYMBOL	CONDITIONS (NOTE 1)		GROUP A SUBGROUPS	TEMPERATURE	LIMITS		UNITS
						MIN	MAX	
Supply Current	IDD	VDD = 20V, VIN = VDD or GND		1	+25°C	-	10	µA
				2	+125°C	-	1000	µA
		VDD = 18V, VIN = VDD or GND		3	-55°C	-	10	µA
Input Leakage Current	IIL	VIN = VDD or GND	VDD = 20	1	+25°C	-100	-	nA
				2	+125°C	-1000	-	nA
				3	-55°C	-100	-	nA
Input Leakage Current	IIH	VIN = VDD or GND	VDD = 20	1	+25°C	-	100	nA
				2	+125°C	-	1000	nA
				3	-55°C	-	100	nA
Output Voltage	VOL15	VDD = 15V, No Load		1, 2, 3	+25°C, +125°C, -55°C	-	50	mV
Output Voltage	VOH15	VDD = 15V, No Load (Note 3)		1, 2, 3	+25°C, +125°C, -55°C	14.95	-	V
Output Current (Sink)	IOL5	VDD = 5V, VOUT = 0.4V		1	+25°C	0.53	-	mA
Output Current (Sink)	IOL10	VDD = 10V, VOUT = 0.5V		1	+25°C	1.4	-	mA
Output Current (Sink)	IOL15	VDD = 15V, VOUT = 1.5V		1	+25°C	3.5	-	mA
Output Current (Source)	IOH5A	VDD = 5V, VOUT = 4.6V		1	+25°C	-	-0.53	mA
Output Current (Source)	IOH5B	VDD = 5V, VOUT = 2.5V		1	+25°C	-	-1.8	mA
Output Current (Source)	IOH10	VDD = 10V, VOUT = 9.5V		1	+25°C	-	-1.4	mA
Output Current (Source)	IOH15	VDD = 15V, VOUT = 13.5V		1	+25°C	-	-3.5	mA
N Threshold Voltage	VNTH	VDD = 10V, ISS = -10µA		1	+25°C	-2.8	-0.7	V
P Threshold Voltage	VPTH	VSS = 0V, IDD = 10µA		1	+25°C	0.7	2.8	V
Functional	F	VDD = 2.8V, VIN = VDD or GND		7	+25°C	VOH > VDD/2	VOL < VDD/2	V
		VDD = 20V, VIN = VDD or GND		7	+25°C			
		VDD = 18V, VIN = VDD or GND		8A	+125°C			
		VDD = 3V, VIN = VDD or GND		8B	-55°C			
Input Voltage Low (Note 2)	VIL	VDD = 5V, VOH > 4.5V, VOL < 0.5V		1, 2, 3	+25°C, +125°C, -55°C	-	1.5	V
Input Voltage High (Note 2)	VIH	VDD = 5V, VOH > 4.5V, VOL < 0.5V		1, 2, 3	+25°C, +125°C, -55°C	3.5	-	V
Input Voltage Low (Note 2)	VIL	VDD = 15V, VOH > 13.5V, VOL < 1.5V		1, 2, 3	+25°C, +125°C, -55°C	-	4	V
Input Voltage High (Note 2)	VIH	VDD = 15V, VOH > 13.5V, VOL < 1.5V		1, 2, 3	+25°C, +125°C, -55°C	11	-	V

NOTES: 1. All voltages referenced to device GND, 100% testing being implemented.
 2. Go/No Go test with limits applied to inputs.
 3. For accuracy, voltage is measured differentially to VDD. Limit is 0.050V max.

7

LOGIC

Specifications CD4014BMS, CD4021BMS

TABLE 2. AC ELECTRICAL PERFORMANCE CHARACTERISTICS

PARAMETER	SYMBOL	CONDITIONS (NOTE 1, 2)	GROUP A SUBGROUPS	TEMPERATURE	LIMITS		UNITS
					MIN	MAX	
Propagation Delay	TPHL TPLH	VDD = 5V, VIN = VDD or GND	9	+25°C	-	320	ns
			10, 11	+125°C, -55°C	-	432	ns
Transition Time	TTHL TTLH	VDD = 5V, VIN = VDD or GND	9	+25°C	-	200	ns
			10, 11	+125°C, -55°C	-	270	ns
Maximum Clock Input Frequency	FCL	VDD = 5V, VIN = VDD or GND	9	+25°C	3	-	MHz
			10, 11	+125°C, -55°C	2.22	-	MHz

NOTES:

1. CL = 50pF, RL = 200K, Input TR, TF < 20ns.
2. -55°C and +125°C limits guaranteed, 100% testing being implemented.

TABLE 3. ELECTRICAL PERFORMANCE CHARACTERISTICS

PARAMETER	SYMBOL	CONDITIONS	NOTES	TEMPERATURE	LIMITS		UNITS
					MIN	MAX	
Supply Current	IDD	VDD = 5V, VIN = VDD or GND	1, 2	-55°C, +25°C	-	5	µA
				+125°C	-	150	µA
		VDD = 10V, VIN = VDD or GND	1, 2	-55°C, +25°C	-	10	µA
				+125°C	-	300	µA
		VDD = 15V, VIN = VDD or GND	1, 2	-55°C, +25°C	-	10	µA
				+125°C	-	600	µA
Output Voltage	VOL	VDD = 5V, No Load	1, 2	+25°C, +125°C, -55°C	-	50	mV
Output Voltage	VOL	VDD = 10V, No Load	1, 2	+25°C, +125°C, -55°C	-	50	mV
Output Voltage	VOH	VDD = 5V, No Load	1, 2	+25°C, +125°C, -55°C	4.95	-	V
Output Voltage	VOH	VDD = 10V, No Load	1, 2	+25°C, +125°C, -55°C	9.95	-	V
Output Current (Sink)	IOL5	VDD = 5V, VOUT = 0.4V	1, 2	+125°C	0.36	-	mA
				-55°C	0.64	-	mA
Output Current (Sink)	IOL10	VDD = 10V, VOUT = 0.5V	1, 2	+125°C	0.9	-	mA
				-55°C	1.6	-	mA
Output Current (Sink)	IOL15	VDD = 15V, VOUT = 1.5V	1, 2	+125°C	2.4	-	mA
				-55°C	4.2	-	mA
Output Current (Source)	IOH5A	VDD = 5V, VOUT = 4.6V	1, 2	+125°C	-	-0.36	mA
				-55°C	-	-0.64	mA
Output Current (Source)	IOH5B	VDD = 5V, VOUT = 2.5V	1, 2	+125°C	-	-1.15	mA
				-55°C	-	-2.0	mA
Output Current (Source)	IOH10	VDD = 10V, VOUT = 9.5V	1, 2	+125°C	-	-0.9	mA
				-55°C	-	-1.6	mA
Output Current (Source)	IOH15	VDD = 15V, VOUT = 13.5V	1, 2	+125°C	-	-2.4	mA
				-55°C	-	-4.2	mA
Input Voltage Low	VIL	VDD = 10V, VOH > 9V, VOL < 1V	1, 2	+25°C, +125°C, -55°C	-	3	V
Input Voltage High	VIH	VDD = 10V, VOH > 9V, VOL < 1V	1, 2	+25°C, +125°C, -55°C	7	-	V

Specifications CD4014BMS, CD4021BMS

TABLE 3. ELECTRICAL PERFORMANCE CHARACTERISTICS (Continued)

PARAMETER	SYMBOL	CONDITIONS	NOTES	TEMPERATURE	LIMITS		UNITS
					MIN	MAX	
Propagation Delay	TPHL	VDD = 10V	1, 2, 3	+25°C	-	160	ns
	TPLH	VDD = 15V	1, 2, 3	+25°C	-	120	ns
Transition Time	TTHL	VDD = 10V	1, 2, 3	+25°C	-	100	ns
	TTLH	VDD = 15V	1, 2, 3	+25°C	-	80	ns
Maximum Clock Input Frequency	FCL	VDD = 10V	1, 2, 3	+25°C	6	-	MHz
		VDD = 15V	1, 2, 3	+25°C	8.5	-	MHz
Clock Rise and Fall Time (Note 4)	TRCL TFCL	VDD = 5V	3, 5	+25°C	-	15	µs
		VDD = 10V	3, 5	+25°C	-	15	µs
		VDD = 15V	3, 5	+25°C	-	15	µs
Minimum Hold Time Serial In, Parallel In Parallel/Serial Control	TH	VDD = 5V	1, 2, 3	+25°C	-	0	ns
		VDD = 10V	1, 2, 3	+25°C	-	0	ns
		VDD = 15V	1, 2, 3	+25°C	-	0	ns
Minimum Clock Pulse Width	TW	VDD = 5V	1, 2, 3	+25°C	-	180	ns
		VDD = 10V	1, 2, 3	+25°C	-	80	ns
		VDD = 15V	1, 2, 3	+25°C	-	50	ns
Minimum Setup Time Serial Input (Ref. to CL)	TS	VDD = 5V	2, 3	+25°C	-	120	ns
		VDD = 10V	2, 3	+25°C	-	80	ns
		VDD = 15V	2, 3	+25°C	-	60	ns
Minimum Setup Time Parallel Inputs CD4014BMS (Ref. to CL)	TS	VDD = 5V	2, 3	+25°C	-	80	ns
		VDD = 10V	2, 3	+25°C	-	50	ns
		VDD = 15V	2, 3	+25°C	-	40	ns
Minimum Setup Time Parallel Inputs CD4021BMS (Ref. to P/S)	TS	VDD = 5V	2, 3	+25°C	-	50	ns
		VDD = 10V	2, 3	+25°C	-	30	ns
		VDD = 15V	2, 3	+25°C	-	20	ns
Minimum Setup Time Parallel/Serial Control CD4014BMS (Ref. to CL)	TS	VDD = 5V	2, 3	+25°C	-	180	ns
		VDD = 10V	2, 3	+25°C	-	80	ns
		VDD = 15V	2, 3	+25°C	-	60	ns
Minimum P/S Pulse Width (CD4021BMS)	TWH	VDD = 5V	2, 3	+25°C	-	160	ns
		VDD = 10V	2, 3	+25°C	-	80	ns
		VDD = 15V	2, 3	+25°C	-	50	ns
Minimum P/S Removal Time CD4021BMS (Ref. to CL)	TREM	VDD = 5V	2, 3	+25°C	-	280	ns
		VDD = 10V	2, 3	+25°C	-	140	ns
		VDD = 15V	2, 3	+25°C	-	100	ns
Input Capacitance	CIN	Any Input	1, 2	+25°C	-	7.5	pF

NOTES:

1. All voltages referenced to device GND.
2. The parameters listed on Table 3 are controlled via design or process and are not directly tested. These parameters are characterized on initial design release and upon design changes which would affect these characteristics.
3. CL = 50pF, RL = 200K, Input TR, TF < 20ns.
4. If more than one unit is cascaded, TRCL should be made less than or equal to the sum of the transition time and the fixed propagation delay of the output of the driving stage for the estimated capacitive load.

Specifications CD4014BMS, CD4021BMS

TABLE 8. BURN-IN AND IRRADIATION TEST CONNECTIONS

FUNCTION	OPEN	GROUND	VDD	9V ± 0.5V	OSCILLATOR	
					50kHz	25kHz
Static Burn-In 1 (Note 1)	2, 3, 12	1,4-11, 13-15	16			
Static Burn-In 2 (Note 1)	2, 3, 12	8	1, 4-7, 9-11, 13-6			
Dynamic Burn-In (Note 1)	-	1, 4-9, 13-15	16	2, 3, 12	10	11
Irradiation (Note 2)	2, 3, 12	8	1, 4-7, 9-11, 13-16			

NOTE:

1. Each pin except VDD and GND will have a series resistor of 10K ± 5%; VDD = 18V ± 0.5V
2. Each pin except VDD and GND will have a series resistor of 47K ± 5%; Group E, Subgroup 2, sample size is 4 dice/wafer, 0 failures, VDD = 10V ± 0.5V

Logic Diagram

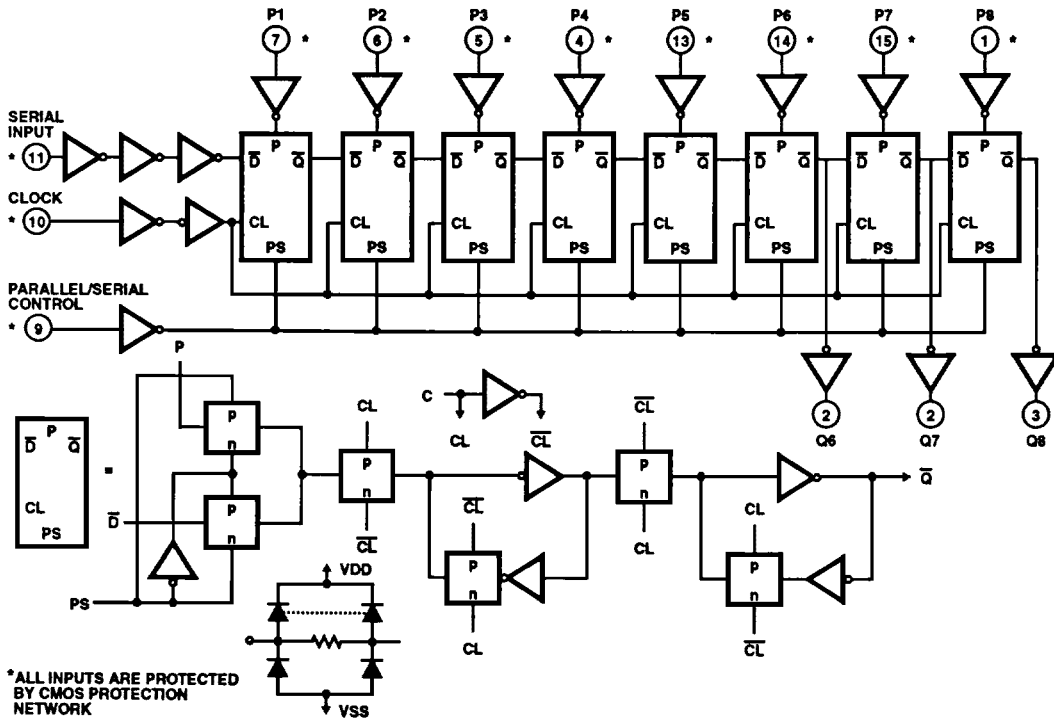

FIGURE 1. CD4014BM LOGIC DIAGRAM

TRUTH TABLE - CD4014BMS

CL	SERIAL INPUT	PARALLEL/SERIAL CONTROL	Pl-1	Pl-n	Q1 (INTERNAL)	Qn
	X	1	0	0	0	0
	X	1	1	0	1	0
	X	1	0	1	0	1
	X	1	1	1	1	1
	0	0	X	X	0	Qn-1
	1	0	X	X	1	Qn-1
	X	X	X	X	Q1	Qn

NC

X = Don't Care Case

NC = No Change

CD4014BMS, CD4021BMS

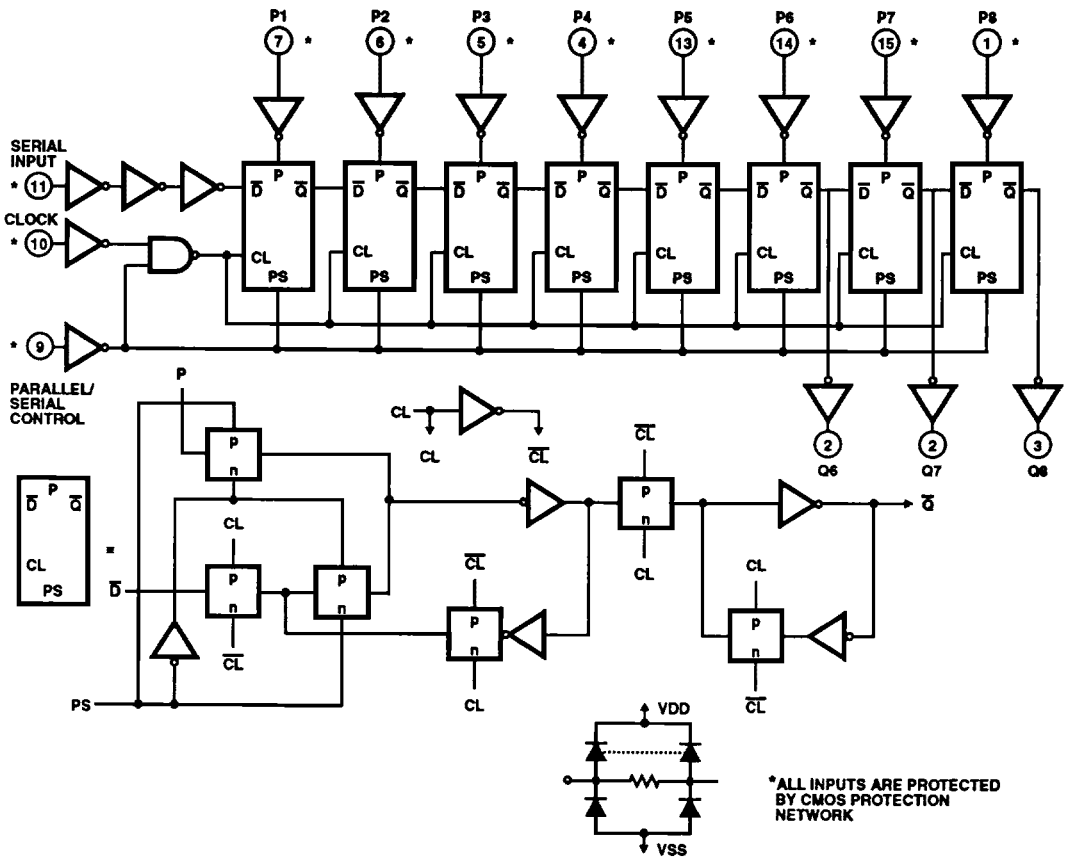

FIGURE 2. CD4021BMS LOGIC DIAGRAM

TRUTH TABLE - CD4021BMS

CL	SERIAL INPUT	PARALLEL/SERIAL CONTROL	PI-1	PI-n	Q1 (INTERNAL)	Qn
X	X	1	0	0	0	0
X	X	1	0	1	0	1
X	X	1	1	0	1	0
X	X	1	1	1	1	1
	0	0	X	X	0	Qn-1
	1	0	X	X	1	Qn-1
	X	0	X	X	Q1	Qn

X = Don't Care Case

NC

Typical Performance Characteristics

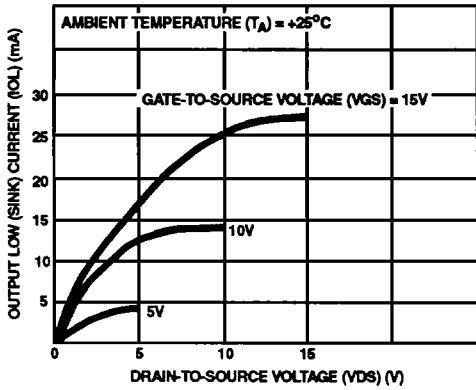

FIGURE 3. TYPICAL OUTPUT LOW (SINK) CURRENT CHARACTERISTICS

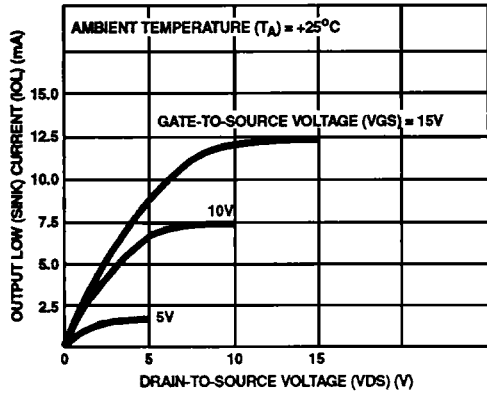

FIGURE 4. MINIMUM OUTPUT LOW (SINK) CURRENT CHARACTERISTICS

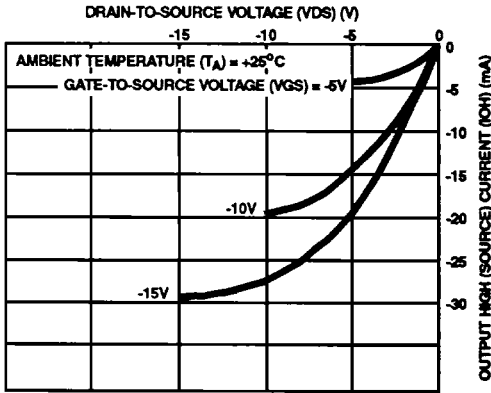

FIGURE 5. TYPICAL OUTPUT HIGH (SOURCE) CURRENT CHARACTERISTICS

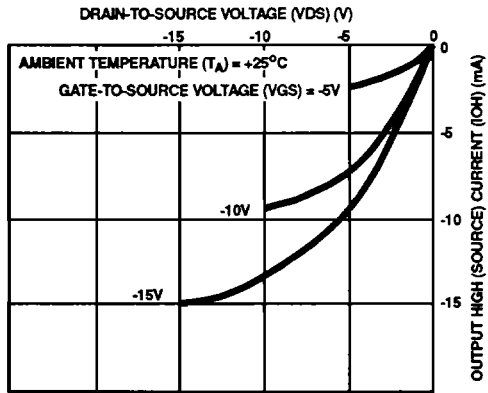

FIGURE 6. MINIMUM OUTPUT HIGH (SOURCE) CURRENT CHARACTERISTICS

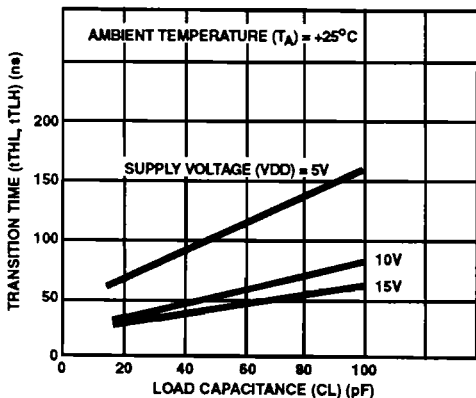

FIGURE 7. TYPICAL TRANSITION TIME AS A FUNCTION OF LOAD CAPACITANCE

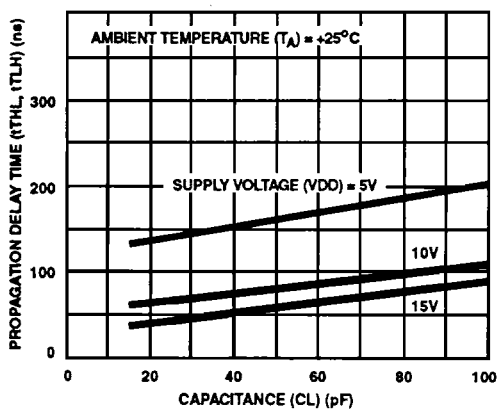

FIGURE 8. TYPICAL PROPAGATION DELAY TIME AS A FUNCTION OF LOAD CAPACITANCE

CD4014BMS, CD4021BMS

Typical Performance Characteristics (Continued)

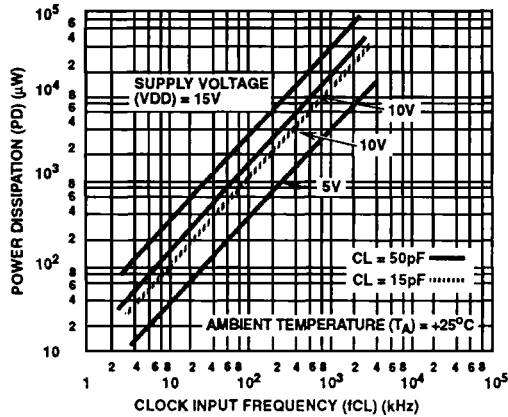
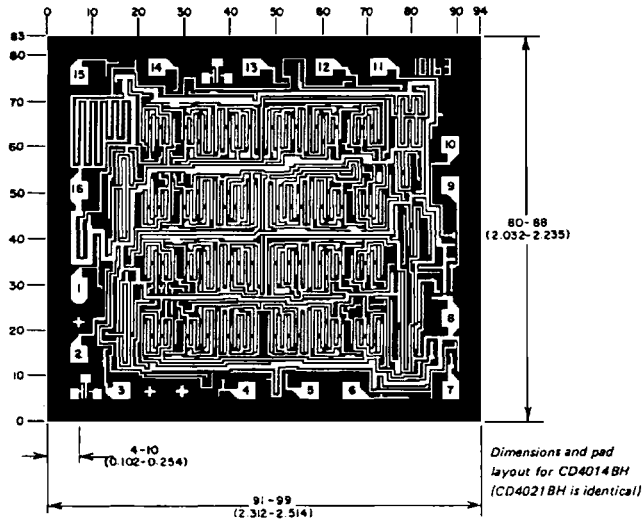

FIGURE 9. TYPICAL POWER DISSIPATION AS A FUNCTION OF FREQUENCY

Chip Dimensions and Pad Layouts



Dimensions in parentheses are in millimeters and are derived from the basic inch dimensions as indicated. Grid graduations are in mils (10^{-3} inch)

METALLIZATION: Thickness: $11\text{k}\text{\AA} - 14\text{k}\text{\AA}$, AL.

PASSIVATION: $10.4\text{k}\text{\AA} - 15.6\text{k}\text{\AA}$, Silane

BOND PADS: 0.004 inches X 0.004 inches MIN

DIE THICKNESS: 0.0198 inches - 0.0218 inches