

## Silicon PIN Photodiode

### Description

BPW83 is a high speed and high sensitive PIN photodiode in a flat side view plastic package. The epoxy package itself is an IR filter, spectrally matched to GaAs or GaAlAs IR emitters ( $\lambda_p \geq 800 \text{ nm}$ ).

The large active area combined with a flat case gives a high sensitivity at a wide viewing angle.

### Features

- Large radiant sensitive area ( $A=7.5 \text{ mm}^2$ )
- Wide angle of half sensitivity  $\phi = \pm 65^\circ$
- High radiant sensitivity
- Fast response times
- Small junction capacitance
- Plastic case with IR filter
- Suitable for near infrared radiation
- Especially for GaAlAs emitters with  $\lambda_p=870\text{nm}$

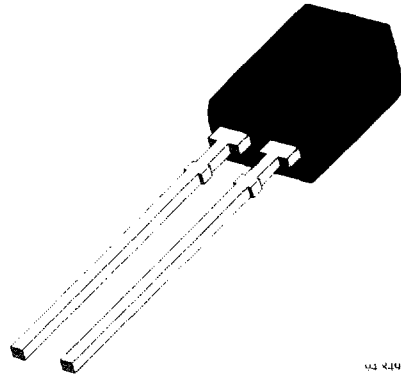

### Applications

High speed photo detector

### Absolute Maximum Ratings

$T_{\text{amb}} = 25^\circ\text{C}$

Parameter	Test Conditions	Symbol	Value	Unit
Reverse Voltage		$V_R$	60	V
Power Dissipation	$T_{\text{amb}} \leq 25^\circ\text{C}$	$P_V$	215	mW
Junction Temperature		$T_J$	100	$^\circ\text{C}$
Storage Temperature Range		$T_{\text{stg}}$	-55...+100	$^\circ\text{C}$
Soldering Temperature	$t \leq 5 \text{ s}$	$T_{\text{sd}}$	260	$^\circ\text{C}$
Thermal Resistance Junction/Ambient		$R_{\text{thJA}}$	350	K/W

## Basic Characteristics

$T_{amb} = 25^{\circ}\text{C}$

Parameter	Test Conditions	Symbol	Min	Typ	Max	Unit
Breakdown Voltage	$I_R = 100 \mu\text{A}, E = 0$	$V_{(BR)}$	60			V
Reverse Dark Current	$V_R = 10 \text{V}, E = 0$	$I_{ro}$		2	30	nA
Diode Capacitance	$V_R = 0 \text{V}, f = 1 \text{MHz}, E = 0$	$C_D$		70		pF
	$V_R = 3 \text{V}, f = 1 \text{MHz}, E = 0$	$C_D$		25	40	pF
Open Circuit Voltage	$E_c = 1 \text{mW/cm}^2, \lambda = 870 \text{nm}$	$V_o$		350		mV
Short Circuit Current	$E_c = 1 \text{mW/cm}^2, \lambda = 870 \text{nm}$	$I_k$		38		$\mu\text{A}$
Reverse Light Current	$E_c = 1 \text{mW/cm}^2, \lambda = 870 \text{nm}, V_R = 5 \text{V}$	$I_{ra}$	43	45		$\mu\text{A}$
Angle of Half Sensitivity		$\phi$		$\pm 65$		deg
Wavelength of Peak Sensitivity		$\lambda_p$		950		nm
Range of Spectral Bandwidth		$\lambda_{0.5}$		790...1050		nm
Noise Equivalent Power	$V_R = 10\text{V}, \lambda = 870\text{nm}$	NEP		$4 \times 10^{-14}$		$\text{W}/\sqrt{\text{Hz}}$
Rise Time	$V_R = 10\text{V}, R_L = 1\text{k}\Omega, \lambda = 820\text{nm}$	$t_r$		100		ns
Fall Time	$V_R = 10\text{V}, R_L = 1\text{k}\Omega, \lambda = 820\text{nm}$	$t_f$		100		ns

## Typical Characteristics ( $T_{amb} = 25^{\circ}\text{C}$ unless otherwise specified)

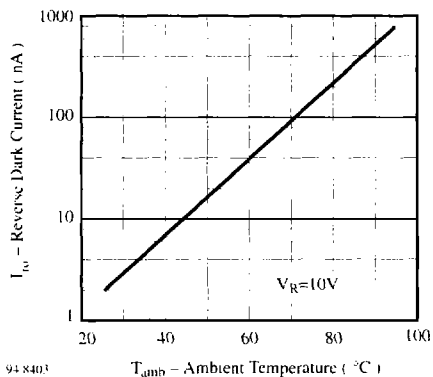

Figure 1. Reverse Dark Current vs. Ambient Temperature

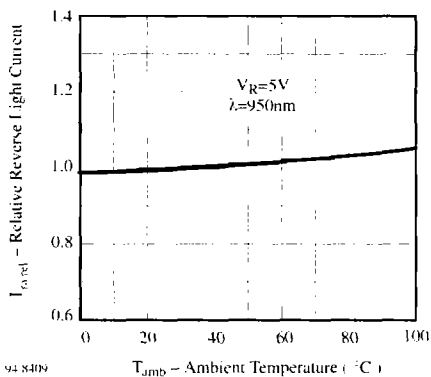

Figure 2. Relative Reverse Light Current vs. Ambient Temperature

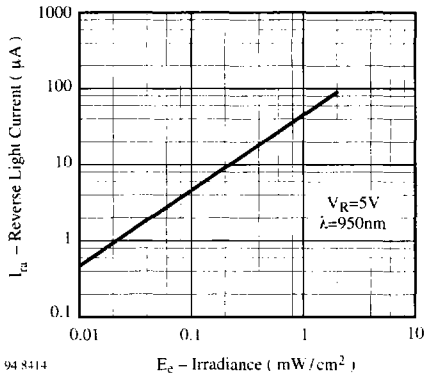

Figure 3. Reverse Light Current vs. Irradiance

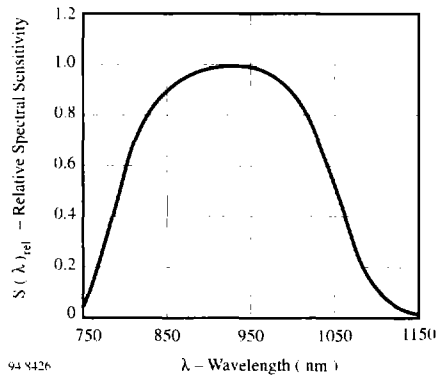

Figure 6. Relative Spectral Sensitivity vs. Wavelength

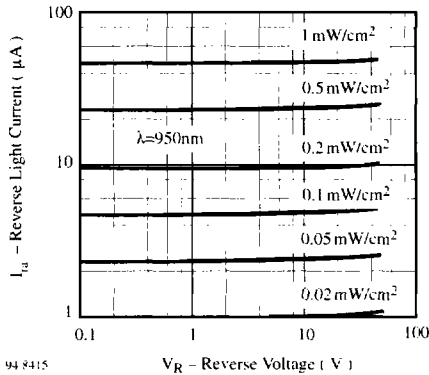

Figure 4. Reverse Light Current vs. Reverse Voltage

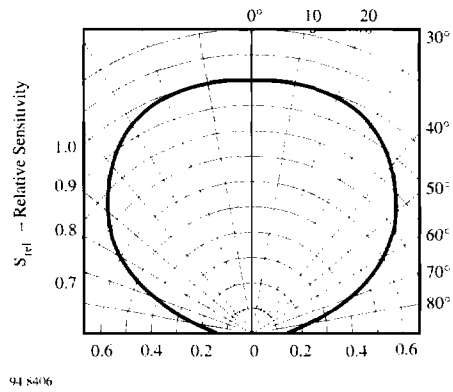

Figure 7. Relative Radiant Sensitivity vs. Angular Displacement

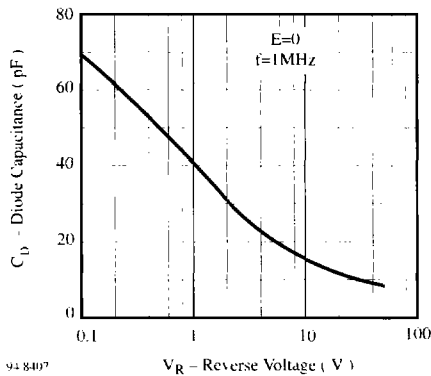
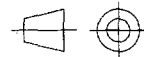
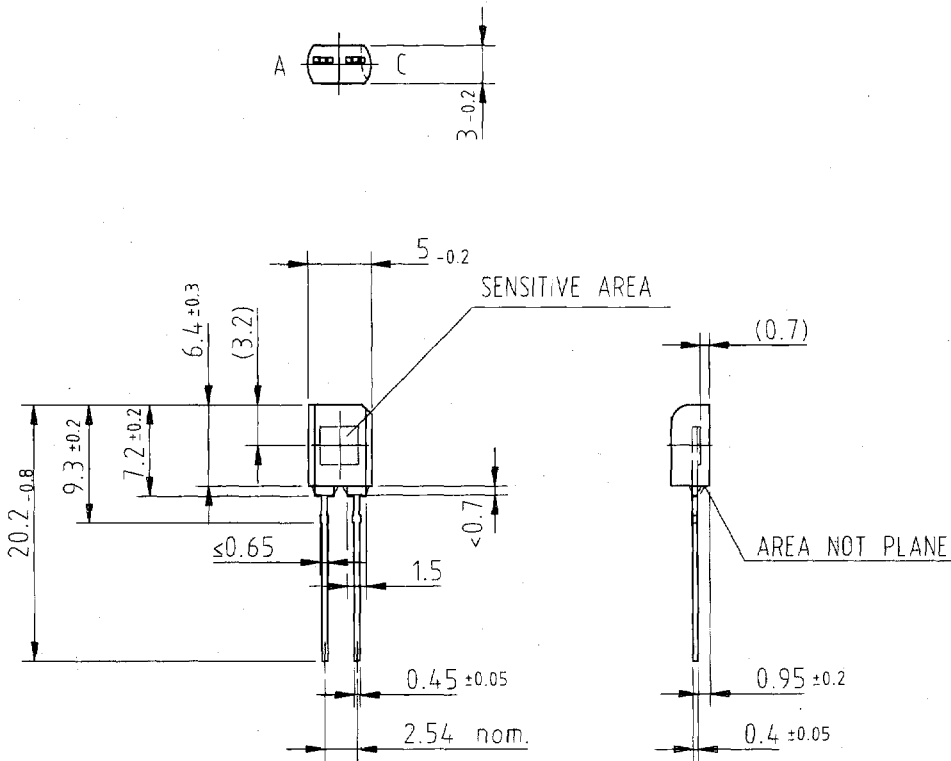

Figure 5. Diode Capacitance vs. Reverse Voltage

**Dimensions in mm**



96 12196

technical drawings  
according to DIN  
specifications