

1-71-11-07

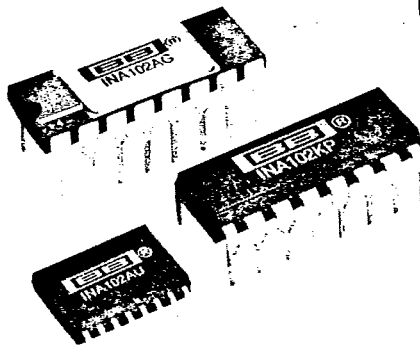

INA102

Low-Power, High-Accuracy INSTRUMENTATION AMPLIFIER

FEATURES

- LOW-QUIESCENT POWER: 750 μ A, max
- INTERNAL GAINS: 1, 10, 100, 1000
- LOW-GAIN DRIFT: 5ppm/ $^{\circ}$ C, max
- HIGH CMR: 90dB, min
- LOW-OFFSET VOLTAGE DRIFT: 2 μ V/ $^{\circ}$ C, max
- LOW-OFFSET VOLTAGE: 100 μ V, max
- LOW NONLINEARITY: 0.01%, max
- HIGH-INPUT IMPEDANCE: 10¹⁰ Ω
- LOW COST

APPLICATIONS

- AMPLIFICATION OF SIGNALS FROM SOURCES SUCH AS:
 - Strain Gauges
 - Thermocouples
 - RTDs
- REMOTE TRANSDUCER AMPLIFIER
- LOW-LEVEL SIGNAL AMPLIFIER
- MEDICAL INSTRUMENTATION
- MULTICHANNEL SYSTEMS
- BATTERY-POWERED EQUIPMENT

DESCRIPTION

The INA102 is a high-accuracy monolithic instrumentation amplifier designed for signal-conditioning applications where low-quiescent power is desired. On-chip thin-film resistors provide excellent temperature and stability performance. State-of-the-art laser-trimming technology insures high-gain accuracy and common-mode rejection while avoiding expensive external components. These features make the INA102 ideally suited for battery powered and high-volume applications.

The INA102 is also convenient to use. A gain of 1, 10, 100 or 1000 may be selected by simply strapping the appropriate pins together. 5ppm/ $^{\circ}$ C gain drift in low gains can then be achieved without external adjustment. When higher than specified CMR is required, CMR can be trimmed using the pins provided. In addition, balanced filtering can be accomplished in the output stage.

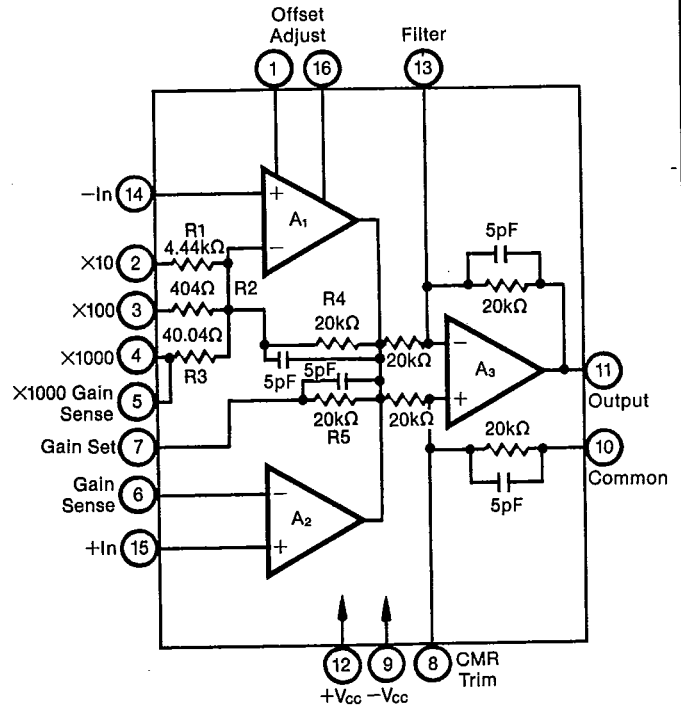

T-71-11-07

SPECIFICATIONS

ELECTRICAL

At $T_A = +25^\circ\text{C}$ with $\pm 15\text{VDC}$ power supply and in circuit of Figure 2 unless otherwise noted.

MODEL	CONDITIONS	INA102AG			INA102CG			INA102KP/INA102AU			UNITS
		MIN	TYP	MAX	MIN	TYP	MAX	MIN	TYP	MAX	
GAIN											
Range of Gain		1		1000	*		*	*		*	V/V
Gain Equation, External, $\pm 20\%$ Error, DC: $G = 1$	$T_A = +25^\circ\text{C}$		$G = 1 + (40k/R_G)^{(1)}$			*		*		*	V/V
$G = 10$	$T_A = +25^\circ\text{C}$			0.1						0.15	%
$G = 100$	$T_A = +25^\circ\text{C}$			0.1						0.35	%
$G = 1000$	$T_A = +25^\circ\text{C}$			0.25						0.4	%
$G = 1$	$T_A = +25^\circ\text{C}$			0.75						0.9	%
$G = 10$	$T_A = T_{MIN}$ to T_{MAX}			0.16						0.21	%
$G = 100$	$T_A = T_{MIN}$ to T_{MAX}			0.19						0.44	%
$G = 1000$	$T_A = T_{MIN}$ to T_{MAX}			0.37						0.52	%
$G = 1000$	$T_A = T_{MIN}$ to T_{MAX}			0.93						1.08	%
Gain Temp. Coefficient											
$G = 1$				10						*	ppm/ $^\circ\text{C}$
$G = 10$				15						*	ppm/ $^\circ\text{C}$
$G = 100$				20						*	ppm/ $^\circ\text{C}$
$G = 1000$				30						*	ppm/ $^\circ\text{C}$
Nonlinearity, DC											
$G = 1$	$T_A = +25^\circ\text{C}$			0.03						0.01	% of FS
$G = 10$	$T_A = +25^\circ\text{C}$			0.03						0.01	% of FS
$G = 100$	$T_A = +25^\circ\text{C}$			0.05						0.02	% of FS
$G = 1000$	$T_A = +25^\circ\text{C}$			0.1						0.05	% of FS
$G = 1$	$T_A = T_{MIN}$ to T_{MAX}			0.045						0.015	% of FS
$G = 10$	$T_A = T_{MIN}$ to T_{MAX}			0.045						0.015	% of FS
$G = 100$	$T_A = T_{MIN}$ to T_{MAX}			0.075						0.03	% of FS
$G = 1000$	$T_A = T_{MIN}$ to T_{MAX}			0.15						0.1	% of FS
RATED OUTPUT											
Voltage	$R_L = 10k\Omega$										V
Current		$\pm(V_{CC} - 2.5)$			*			*			mA
Short-Circuit Current ⁽²⁾		± 1	2		*	*		*	*		mA
Output Impedance			0.1			*		*	*		Ω
INPUT											
OFFSET VOLTAGE											
Initial Offset ⁽³⁾	$T_A = +25^\circ\text{C}$			± 300 $\pm 300/G$				± 100 $\pm 200/G$		*	μV
INA102AU										± 500 $\pm 300/G$	μV
vs Temperature				± 5 $\pm 10/G$				± 2 $\pm 5/G$		*	$\mu\text{V}/^\circ\text{C}$
vs Supply				± 40 $\pm 50/G$				± 10 $\pm 20/G$		*	$\mu\text{V}/\text{V}$
vs Time			$\pm(20$ $+30/G)$			*			*		$\mu\text{V}/\text{mo}$
BIAS CURRENT											
Initial Bias Current (each input)	$T_A = T_{MIN}$ to T_{MAX}			25	50			6	30	*	nA
vs Temperature				± 0.1				*		*	nA/ $^\circ\text{C}$
vs Supply				± 0.1				*		*	nA/V
Initial Offset Current	$T_A = T_{MIN}$ to T_{MAX}			± 2.5	± 15			± 2.5	± 10	*	nA
vs Temperature				± 0.1				*		*	nA/ $^\circ\text{C}$
IMPEDANCE											
Differential				$10^{10} \parallel 2$				*		*	$\Omega \parallel \text{pF}$
Common-mode				$10^{10} \parallel 2$				*		*	$\Omega \parallel \text{pF}$
VOLTAGE RANGE											
Range, Linear Response	$T_A = T_{MIN}$ to T_{MAX}					*			*		V
CMR with 1kΩ											
Source Imbalance											
$G = 1$	DC to 60 Hz	80	94		90	*		75	*		dB
$G = 10$	DC to 60 Hz	80	100		90	*		*	*		dB
$G = 10$ to 1000	DC to 60 Hz	80	100		90	*		*	*		dB
NOISE											
Input Voltage Noise											
$f_B = 0.01\text{Hz}$ to 10Hz				1.0		*			*		$\mu\text{Vp-p}$
Density, $G = 1000$											
$f_o = 10\text{Hz}$				30		*			*		$\text{nV}/\sqrt{\text{Hz}}$
$f_o = 100\text{Hz}$				25		*			*		$\text{nV}/\sqrt{\text{Hz}}$
$f_o = 1\text{kHz}$				25		*			*		$\text{nV}/\sqrt{\text{Hz}}$
Input Current Noise											
$f_B = 0.01\text{Hz}$ to 10Hz				25		*			*		pA p-p
Density: $f_o = 10\text{Hz}$				0.3		*			*		$\text{pA}/\sqrt{\text{Hz}}$
$f_o = 100\text{Hz}$				0.2		*			*		$\text{pA}/\sqrt{\text{Hz}}$
$f_o = 1\text{kHz}$				0.15		*			*		$\text{pA}/\sqrt{\text{Hz}}$

T-71-11-07

ELECTRICAL (CONT)

MODEL	CONDITIONS	INA102AG			INA102CG			INA102KP/INA102AU			UNITS	
		MIN	TYP	MAX	MIN	TYP	MAX	MIN	TYP	MAX		
DYNAMIC RESPONSE												
Small Signal ±3dB Flatness G = 1 G = 10 G = 100 G = 1000	V _{OUT} = 0.1Vrms		300			*			*		kHz	
			30			*			*		kHz	
			3			*			*		kHz	
			0.3			*			*		kHz	
Small Signal, ±1% Flatness G = 1 G = 3 G = 10 G = 100 G = 1000 Full Power, G = 1 to 100 Slew Rate, G = 1 to 100 Settling Time 0.1%: G = 1 G = 100 G = 1000 0.01%: G = 1 G = 100 G = 1000	V _{OUT} = 0.1Vrms		30			*			*		kHz	
			3			*			*		kHz	
			0.3			*			*		kHz	
			0.03			*			*		kHz	
			0.015			*			*		kHz	
	Full Power, G = 1 to 100 Slew Rate, G = 1 to 100	V _{OUT} = 10V, R _L = 10kΩ	1.7	2.5		*	*		*	*		V/μs
		V _{OUT} = 10V, R _L = 10kΩ	0.1	0.15		*	*		*	*		V/μs
	Settling Time 0.1%: G = 1 G = 100 G = 1000 0.01%: G = 1 G = 100 G = 1000	R _L = 10kΩ, C _L = 100pF 10V step		50			*			*		μs
				360			*			*		μs
				3300			*			*		μs
			60			*			*		μs	
			500			*			*		μs	
	4500			*			*		μs			
POWER SUPPLY												
Rated Voltage Voltage Range Quiescent Current	V _O = 0V, T _A = T _{MIN} to T _{MAX}	±3.5	±15	±18	*	*	*	*	*	*	V	
			±500	±750	*	*	*	*	*	*	μA	
TEMPERATURE RANGE												
Specification INA102AU Operation Storage	R _L > 50kΩ ⁽²⁾	-25		+85	*		*	0		+70	°C	
		-25		+85	*		*	-25		+85	°C	
		-65		+150	*		*	-55		+125	°C	

*Specification same as for INA102AG.

NOTES: (1) The internal gain set resistors have an absolute tolerance of ±20%; however, their tracking is 50ppm/°C. R_Ω will add to the gain error if gains other than 1, 10, 100 or 1000 are set externally. (2) At high temperature, output drive current is limited. An external buffer can be used if required. (3) Adjustable to zero at any one time.

MECHANICAL

Hermetic

NOTE: Leads in true position within 0.10" (0.25mm) R at seating plane. Pin numbers shown for reference only. Numbers are not marked on package.

CASE: Ceramic

DIM	INCHES		MILLIMETERS	
	MIN	MAX	MIN	MAX
A	.790	.810	20.07	20.57
C	.105	.170	2.67	4.32
D	.015	.021	0.38	0.53
F	.048	.060	1.22	1.52
G	.100 BASIC		2.54 BASIC	
H	.030	.070	0.76	1.78
J	.008	.012	0.20	0.30
K	.120	.240	3.05	6.10
L	.300 BASIC		7.62 BASIC	
M	—	10°	—	10°
N	.025	.060	0.64	1.52

Plastic

NOTE: Leads in true position within 0.10" (0.25mm) R at seating plane. PINS: Pin material and plating composition conform to method 2003 (solderability) of MIL-STD-883 (except paragraph 3.2).

CASE: Plastic

DIM	INCHES		MILLIMETERS	
	MIN	MAX	MIN	MAX
A	.740	.800	18.80	20.32
A ₁	.725	.785	18.42	19.94
B	.230	.290	5.85	7.38
B ₁	.200	.250	5.09	6.36
C	.120	.200	3.05	5.09
D	.015	.023	0.38	0.59
F	.030	.070	0.76	1.78
G	.100 BASIC		2.54 BASIC	
H	0.02	0.05	0.51	1.27
J	.008	.015	0.20	0.38
K	.070	.150	1.78	3.82
L	.300 BASIC		7.63 BASIC	
M	0°	15°	0°	15°
N	.010	.030	0.25	0.76
P	.025	.050	0.64	1.27

The information provided herein is believed to be reliable; however, BURR-BROWN assumes no responsibility for inaccuracies or omissions. BURR-BROWN assumes no responsibility for the use of this information, and all use of such information shall be entirely at the user's own risk. Prices and specifications are subject to change without notice. No patent rights or licenses to any of the circuits described herein are implied or granted to any third party. BURR-BROWN does not authorize or warrant any BURR-BROWN product for use in life support devices and/or systems.

MECHANICAL

SOIC

DIM	INCHES		MILLIMETERS	
	MIN	MAX	MIN	MAX
A	.400	.416	10.16	10.57
A ₁	.388	.412	9.86	10.46
B	.286	.302	7.26	7.67
B ₁	.268	.286	6.81	7.26
C	.093	.109	2.36	2.77
D	.015	.020	0.38	0.51
G	.050 BASIC		1.27 BASIC	
H	.022	.038	0.56	0.97
J	.008	.012	0.20	0.30
L	.391	.421	9.93	10.69
M	5° TYP		5° TYP	
N	.000	.012	0.00	0.30

NOTE: Leads in true position within .010" (.25mm) R at MMC at seating plane.
Pin numbers shown for reference only. Numbers are not marked on package.

PIN CONFIGURATION

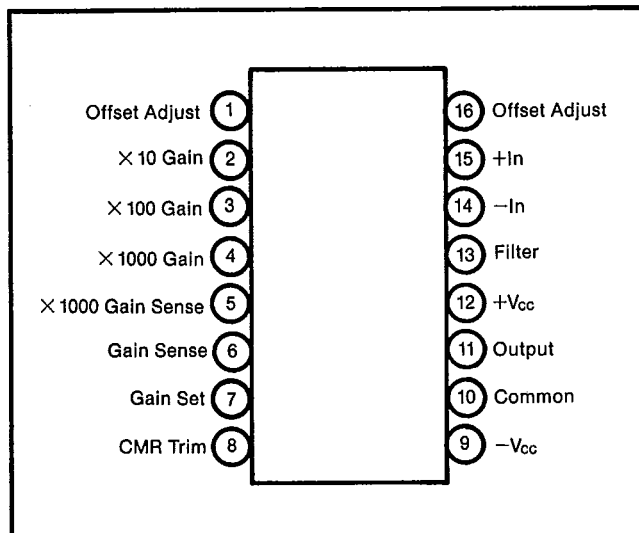

ABSOLUTE MAXIMUM RATINGS

Supply	±18V
Input Voltage Range	±V _{CC}
Operating Temperature Range	-25°C to +85°C
Storage Temperature Range: Ceramic	-65°C to +150°C
Plastic, SOIC	-55°C to +125°C
Lead Temperature (soldering 10 seconds)	+300°C
Output Short-Circuit Duration	Continuous to ground

ORDERING INFORMATION

Model	Package	Temperature Range	Prices		
			1-24	25-99	100+
INA102AG	Ceramic DIP	-25°C to +85°C	\$14.65	\$11.70	\$8.35
INA102CG	Ceramic DIP	-25°C to +85°C	21.65	18.00	12.50
INA102KP	Plastic DIP	0°C to +70°C	8.00	6.25	5.65
INA102AU	Plastic SOIC	-25°C to +85°C	8.70	6.80	6.15

BURN-IN SCREENING OPTION
See text for details.

Model	Package	Burn-In Temp. (160h) ⁽¹⁾	Prices		
			1-24	25-99	100+
INA102AG-BI	Ceramic DIP	+125°C	\$16.15	\$13.20	\$9.85
INA102CG-BI	Ceramic DIP	+125°C	28.15	23.40	16.25
INA102KP-BI	Plastic DIP	+85°C	9.50	7.75	7.15
INA102AU-BI	Plastic SOIC	+85°C	10.95	8.90	8.25

NOTE: (1) Or equivalent combination. See text.

BURN-IN SCREENING

Burn-in screening is an option available for both plastic- and ceramic-packaged INA102s. Burn-in duration is 160 hours at the temperature shown below (or equivalent combination of time and temperature).

- Plastic "-BI" models: +85°C
- Ceramic "-BI" models: +125°C

All units are tested after burn-in to ensure that grade specifications are met. To order burn-in, add "-BI" to the base model number.

TYPICAL PERFORMANCE CURVES

At +25°C and in circuit of Figure 2 unless otherwise noted.

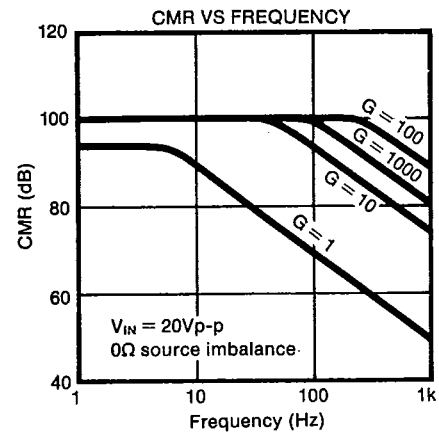
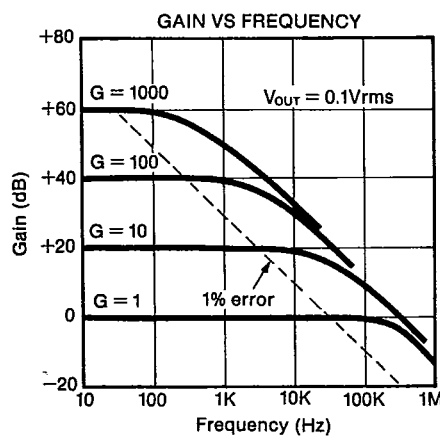
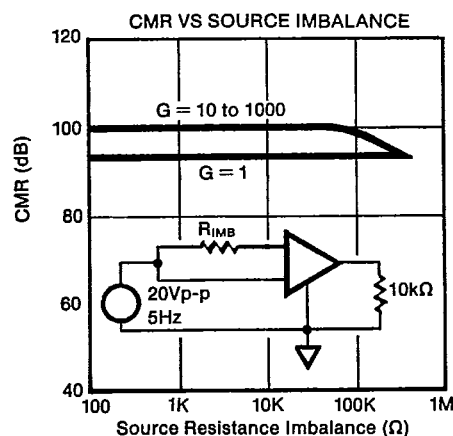

T=71-11-07

TYPICAL PERFORMANCE CURVES (CONT)

At +25°C and in circuit of Figure 2 unless otherwise noted.

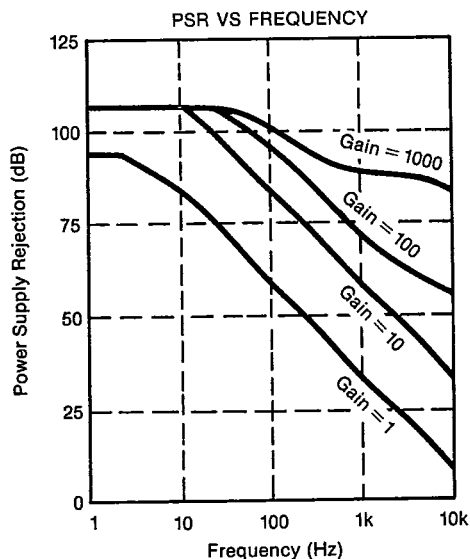
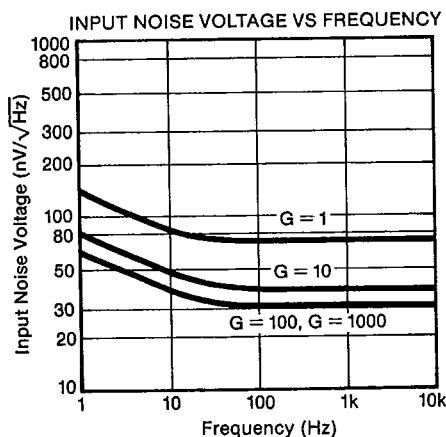
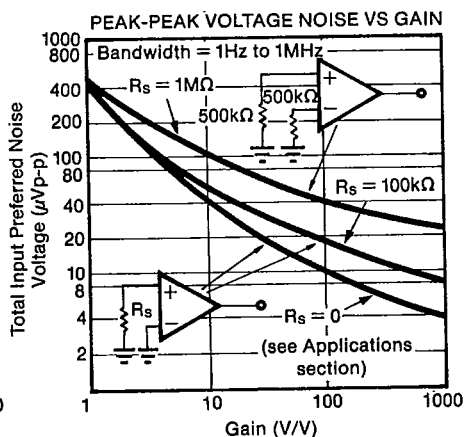
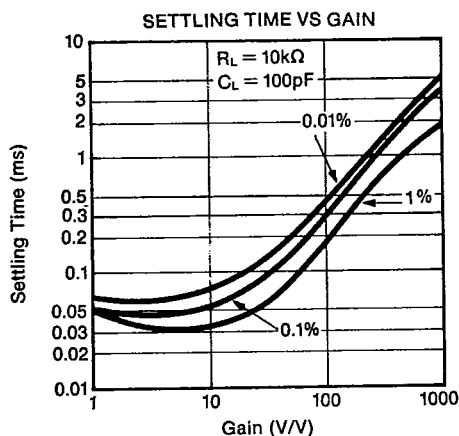
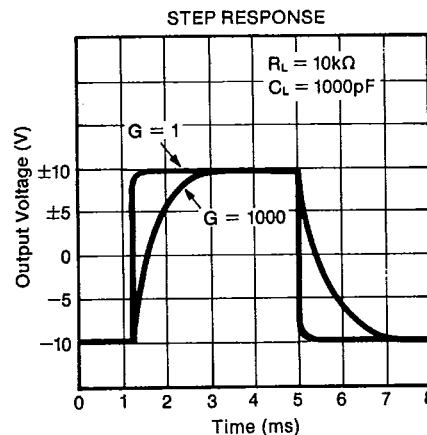
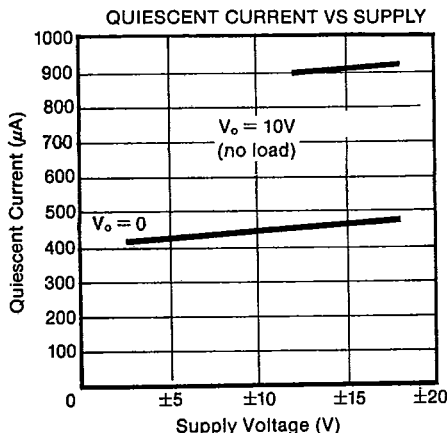
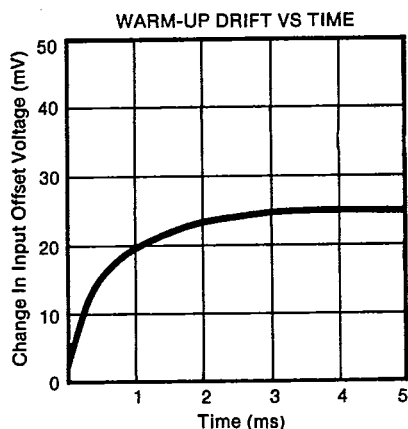

DISCUSSION OF PERFORMANCE

INSTRUMENTATION AMPLIFIERS

Instrumentation amplifiers are differential input closed-loop gain blocks whose committed circuit accurately amplifies the voltage applied to their inputs. They respond mainly to the difference between the two input signals and exhibit extremely high input impedance, both differentially and common-mode. The feedback networks of this instrumentation amplifier is included on the monolithic chip. No external resistors are required for gains of 1, 10, 100, and 1000 in the INA102.

An operational amplifier, on the other hand, is an open-loop, uncommitted device that requires external networks to close the loop. While op amps can be used to achieve the same basic function as instrumentation amplifiers, it is very difficult to reach the same level of performance. Using op amps often leads to design trade-offs when it is necessary to amplify low-level signals in the presence of common-mode voltages while maintaining high-input impedances. Figure 1 shows a simplified model of an instrumentation amplifier that eliminates most of the problems.

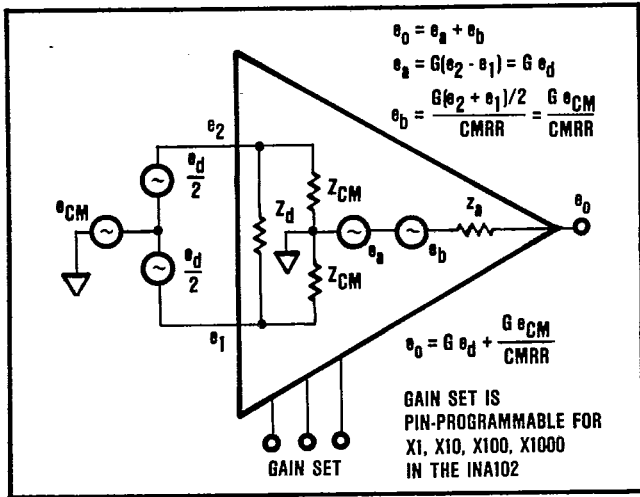

FIGURE 1. Model of an Instrumentation Amplifier.

THE INA102

A simplified schematic of the INA102 is shown on the first page. A three-amplifier configuration is used to provide the desirable characteristics of a premium performance instrumentation amplifier. In addition, it has features not normally found in integrated circuit instrumentation amplifiers.

The input buffers (A1 and A2) incorporate high performance, low-drift amplifier circuitry. The amplifiers are connected in the noninverting configuration to provide the high input impedance ($10^{10}\Omega$) desirable in instrumentation amplifier applications. The offset voltage and offset voltage versus temperature are low due to the monolithic design, and improved even further by state-of-the-art laser-trimming techniques.

The output stage (A3) is connected in a unity-gain differential amplifier configuration. A critical part of this stage is the matching of the four $20k\Omega$ resistors which provide the difference function. These resistors must be initially well matched and the matching must be maintained over temperature and time in order to retain good common-mode rejection.

All of the internal resistors are made of thin-film nichrome on the integrated circuit. The critical resistors are laser-trimmed to provide the desired high-gain accuracy and common-mode rejection. Nichrome ensures long-term stability and provides excellent TCR and TCR tracking. This provides gain accuracy and common-mode rejection when the INA102 is operated over wide temperature ranges.

USING THE INA102

Figure 2 shows the simplest configuration of the INA102. The output voltage is a function of the differential input voltage times the gain.

A gain of 1, 10, 100, or 1000 is selected by programming pins 2 through 7 (see Table I). Notice that for the gain of 1000, a special gain sense is provided to preserve accuracy. Although this is not always required, gain errors caused by external resistance in series with the low value 40.04Ω internal gain set resistor are thus eliminated.

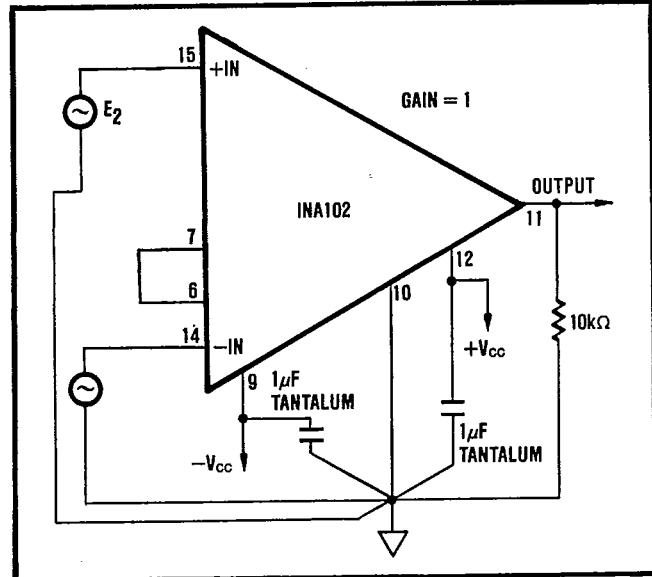

FIGURE 2. Basic Circuit Connection for the INA102.

Other gains between 1 and 10, 10 and 100, and 100 and 1000 can also be obtained by connecting an external resistor between pin 6 and either pin 2, 3, or 4, respectively (see Figure 6 for application).

$G = 1 + (40/R_G)$ where R_G is the total resistance between the two inverting inputs of the input op amps. At high gains, where the value of R_G becomes small, additional resistance (i.e., relays or sockets) in the R_G circuit will contribute to a gain error. Care should be taken to minimize this effect.

TABLE I. Pin-Programmable Gain Connections

GAIN	CONNECT PINS
1	6 to 7
10	2 to 6 and 7
100	3 to 6 and 7
1000	4 to 7 and separately 5 to 6

OPTIONAL OFFSET ADJUSTMENT PROCEDURE

It is sometimes desirable to null the input and/or output offset to achieve higher accuracy. The quality of the potentiometer will affect the results; therefore, choose one with good temperature and mechanical-resistance stability.

The optional offset null capabilities are shown in Figure 3. R_4 adjustment affects only the input stage component of the offset voltage. Note that the null condition will be disturbed when the gain is changed. Also, the input drift will be affected by approximately $0.31\mu V/^\circ C$ per $100\mu V$ of input offset voltage that is trimmed. Therefore, care should be taken when considering use of the control for removal of other sources of offset. Output offset correction can be accomplished with A_1 , R_1 , R_2 , and R_3 , by applying a voltage to Common (pin 10) through a buffer amplifier. This buffer limits the resistance in series with pin 10 to minimize CMR error. Resistance above 0.1Ω will cause the common-mode rejection to fall below 100dB. Be certain to keep this resistance low.

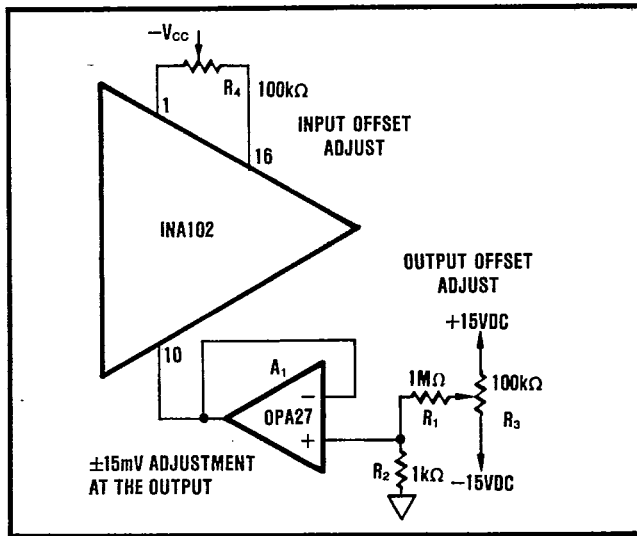

FIGURE 3. Optional Offset Nulling

It is important to not exceed the input amplifiers' dynamic range. The amplified differential input signal and its associated common-mode voltage should not cause the output of A₁ or A₂ to exceed approximately ±12V with ±15V supplies or nonlinear operation will result. To protect against moisture, especially in high gain, sealing compound may be used. Current injected into the offset pins should be minimized.

OPTIONAL FILTERING

The INA102 has provisions for accomplishing filtering with one external capacitor between pins 11 and 13. This single-pole filter can be used to reduce noise outside the signal bandwidth, but with some degradation to AC CMR.

When it is important to preserve CMR versus frequency (especially at 60Hz), two capacitors should be used. The additional capacitor is connected between pins 8 and 10. This will maintain a balance of impedances in the output stage. Either of these capacitors could also be trimmed slightly, to maximize CMR, if desired. Note that their ratio tracking will affect CMR over temperature.

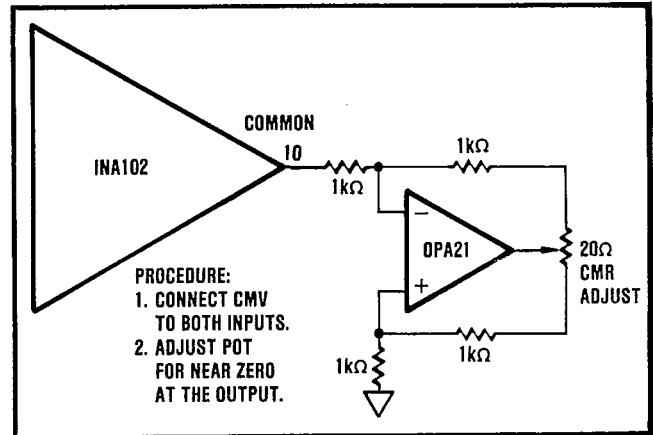

FIGURE 4. Optional Circuit for Externally Trimming CMR.

OPTIONAL COMMON-MODE REJECTION TRIM

The INA102 is laser-adjusted during manufacturing to assure high CMR. However, if desired, a small resistance can be added in series with pin 10 to trim the CMR to an improved level. Depending upon the nature of the internal imbalances, either a positive or negative resistance value could be required. The circuit shown in Figure 4 acts as a bipolar potentiometer and allows easy adjustment of CMR.

TYPICAL APPLICATIONS

Many applications of instrumentation amplifiers involve the amplification of low-level differential signals from bridges and transducers such as strain gauges, thermocouples, and RTDs. Some of the important parameters include common-mode rejection (differential cancellation of common-mode offset and noise, see Figure 1), input impedance, offset voltage and drift, gain accuracy, linearity, and noise. The INA102 accomplishes all of these with high precision at surprisingly low-quiescent current. However, in higher gains (>100), the bias current can cause a large offset error at the output. This can saturate the output unless the source impedance is separated, e.g., two 500kΩ paths instead of one 1MΩ unbalanced input.

Figures 5 through 16 show some typical applications circuits.

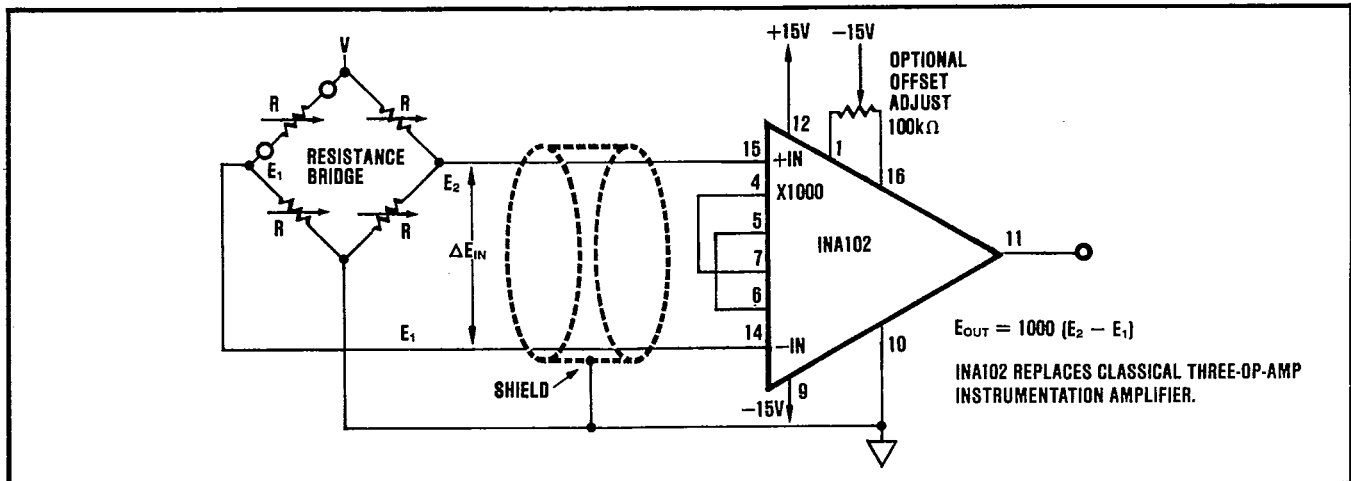

FIGURE 5. Amplification of a Differential Voltage from a Resistance Bridge.

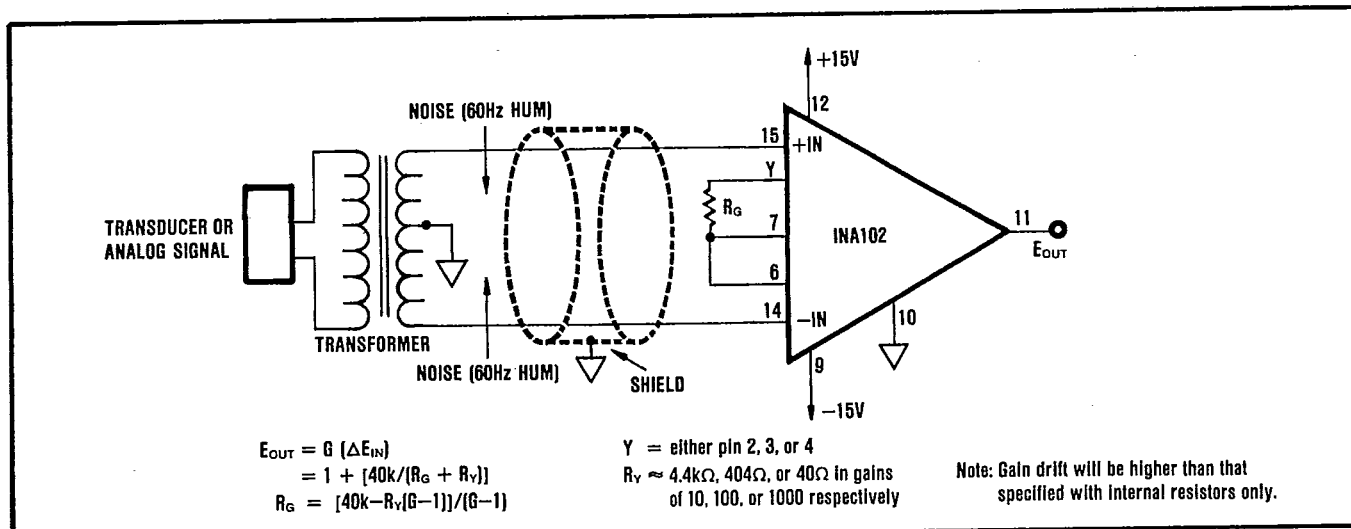

FIGURE 6. Amplification of a Transformer-Coupled Analog Signal Using External Gain Set.

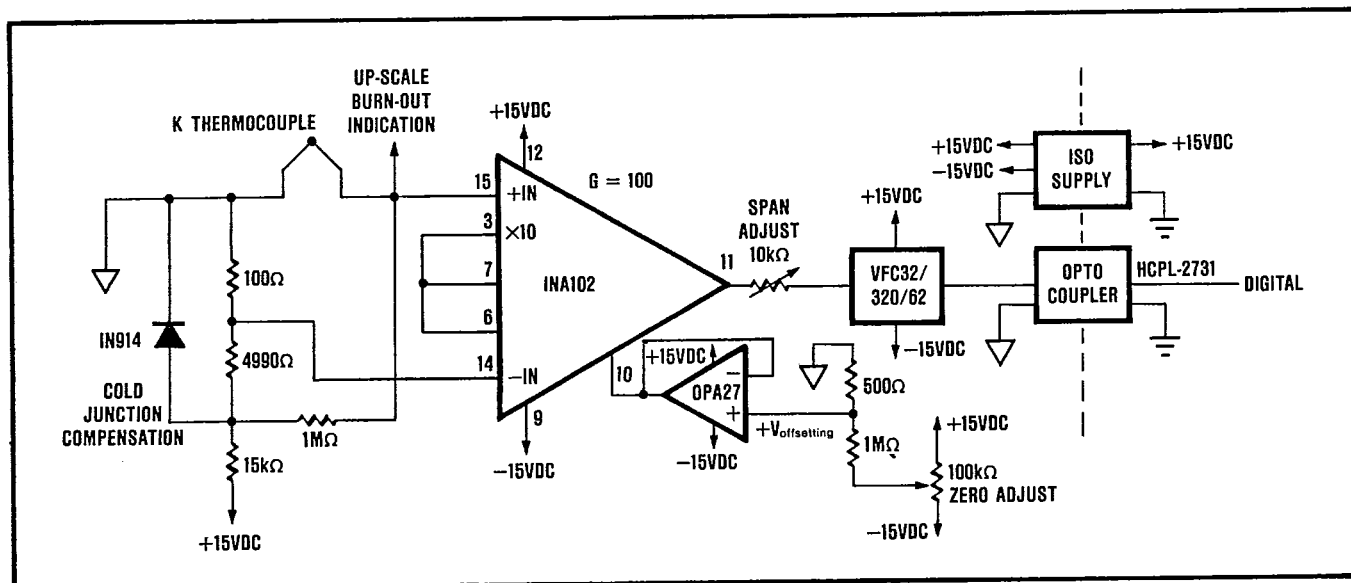

FIGURE 7. Isolated Thermocouple Amplifier with Cold Junction Compensation.

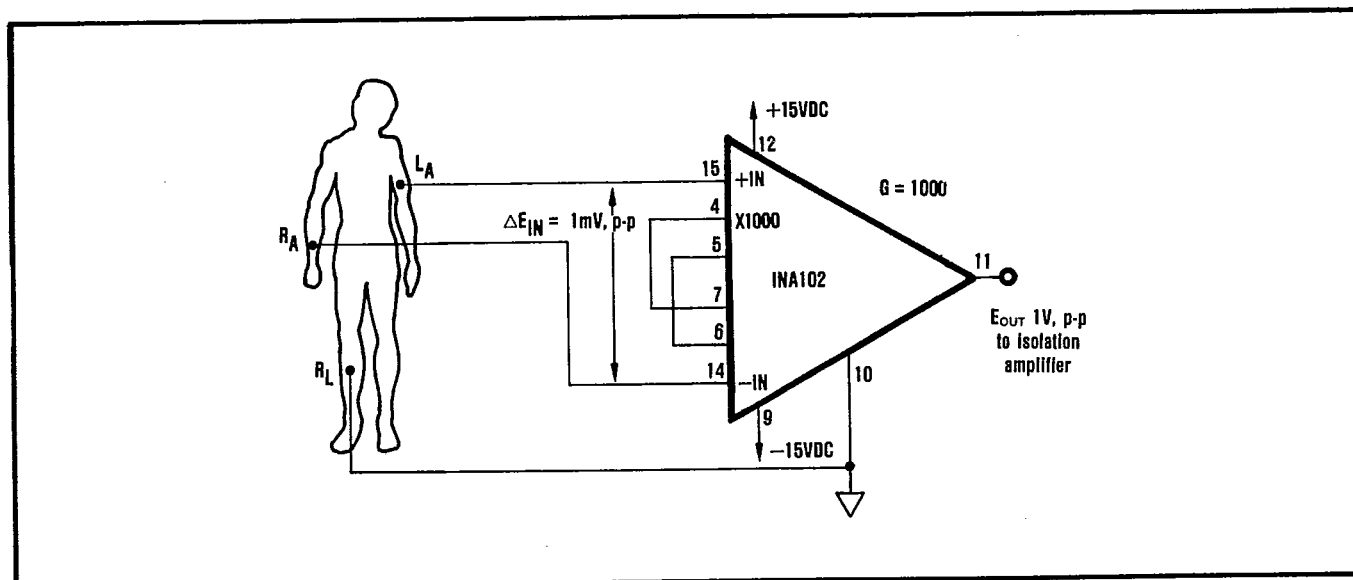

FIGURE 8. ECG Amplifier or Recorder Preamp for Biological Signals.

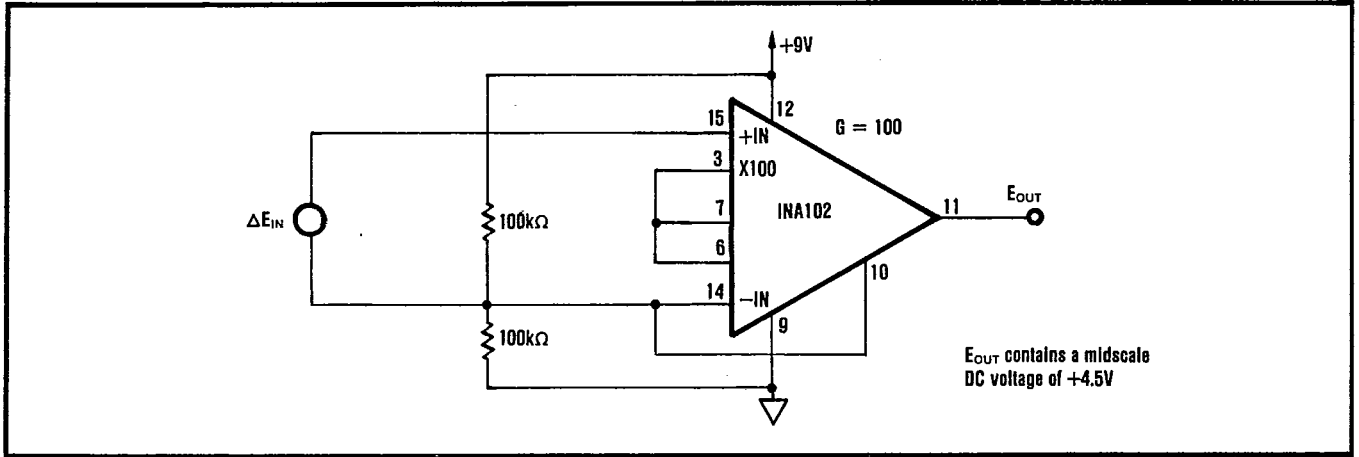

FIGURE 9. Single Supply Low Power Instrumentation Amplifier.

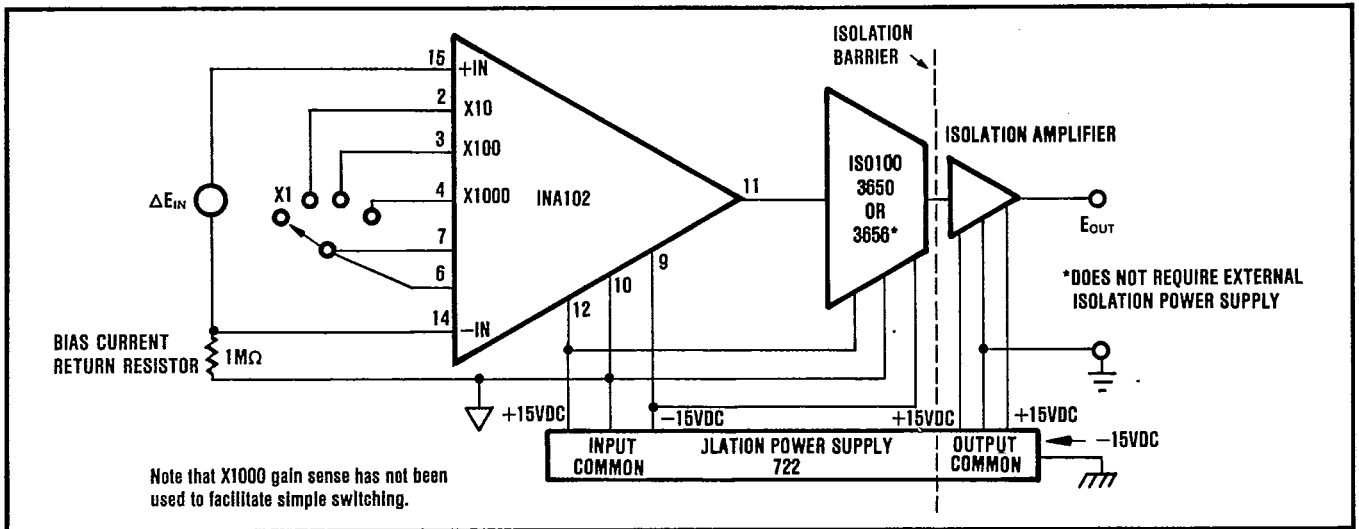

FIGURE 10. Precision Isolated Instrumentation Amplifier.

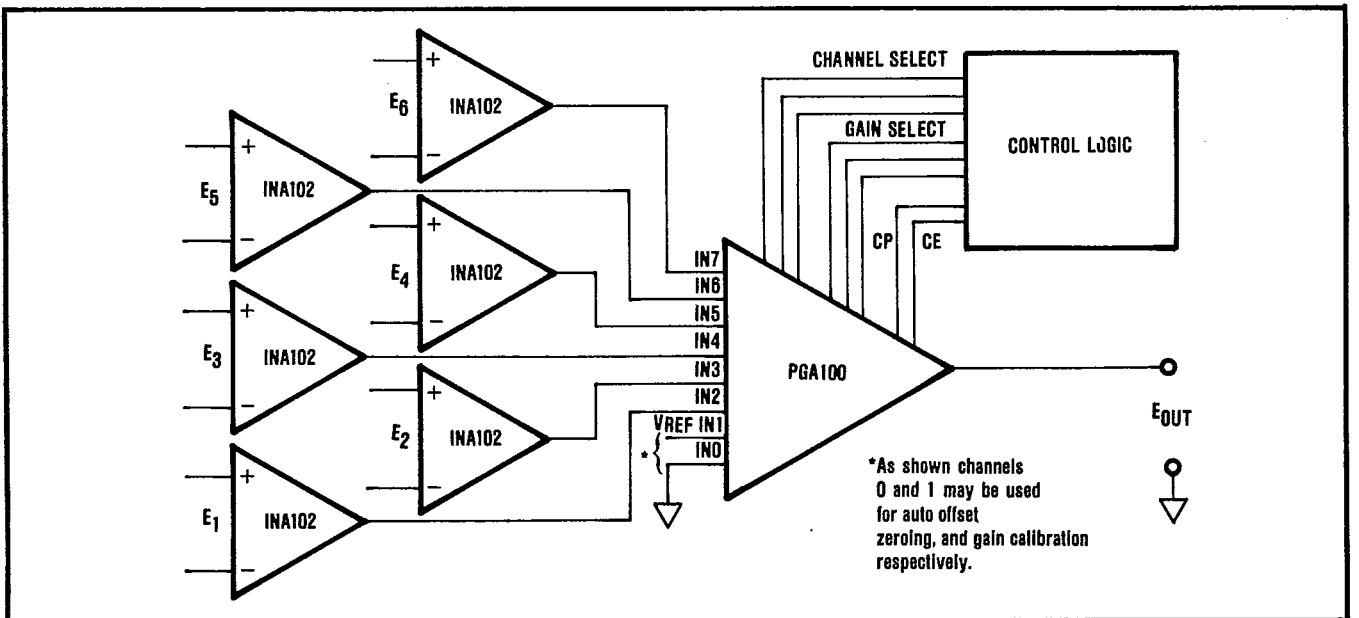

FIGURE 11. Multiple Channel Precision Instrumentation Amplifier with Programmable Gain.

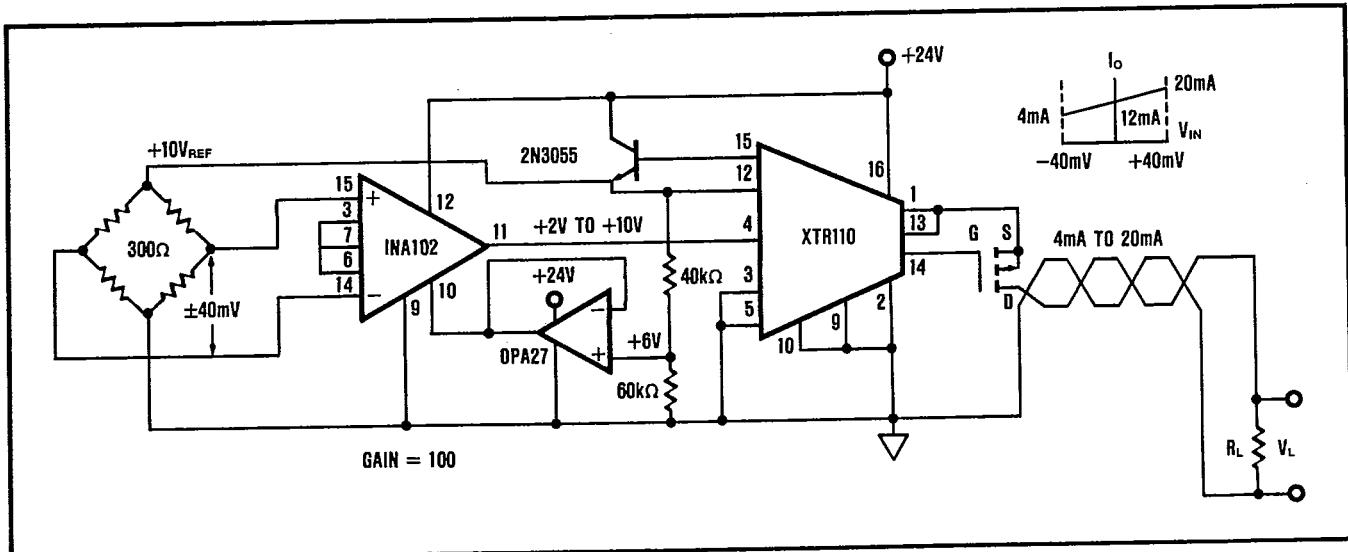

FIGURE 12. 4mA to 20mA Bridge Transmitter Using Single Supply Instrumentation Amplifier.

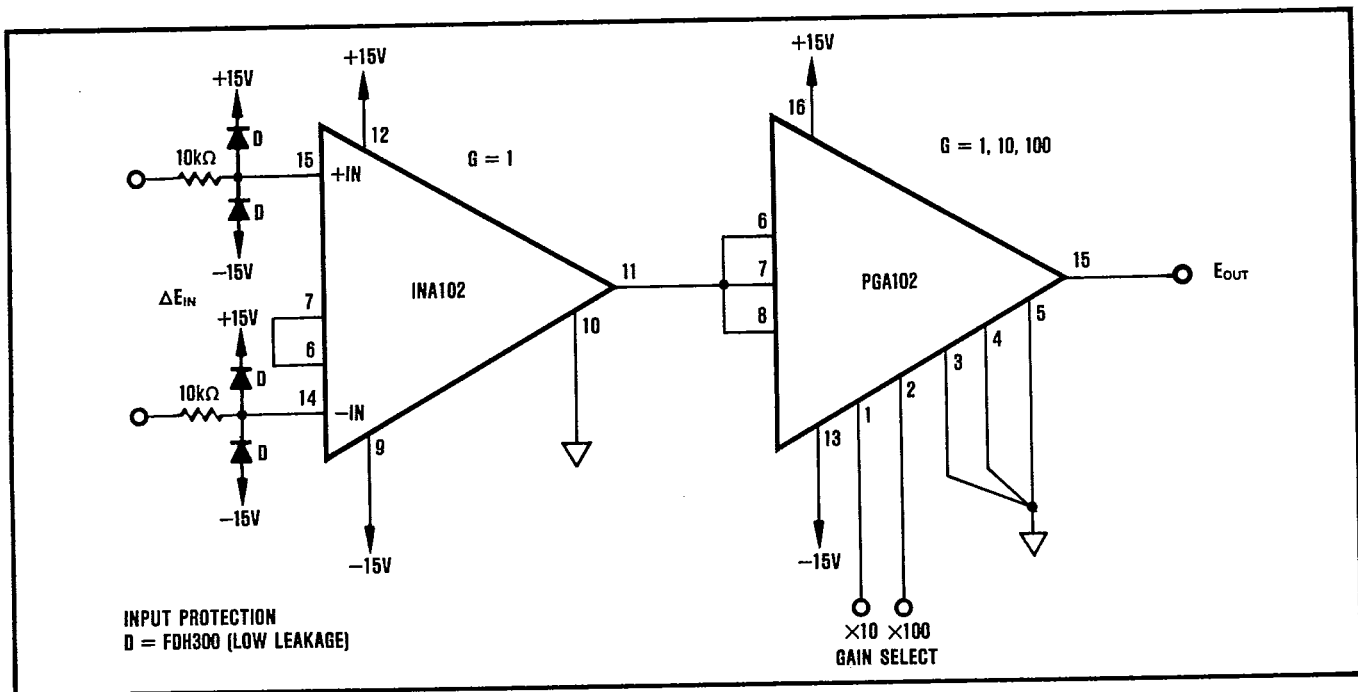

FIGURE 13. Programmable-Gain Instrumentation Amplifier Using the INA102 and PGA102.

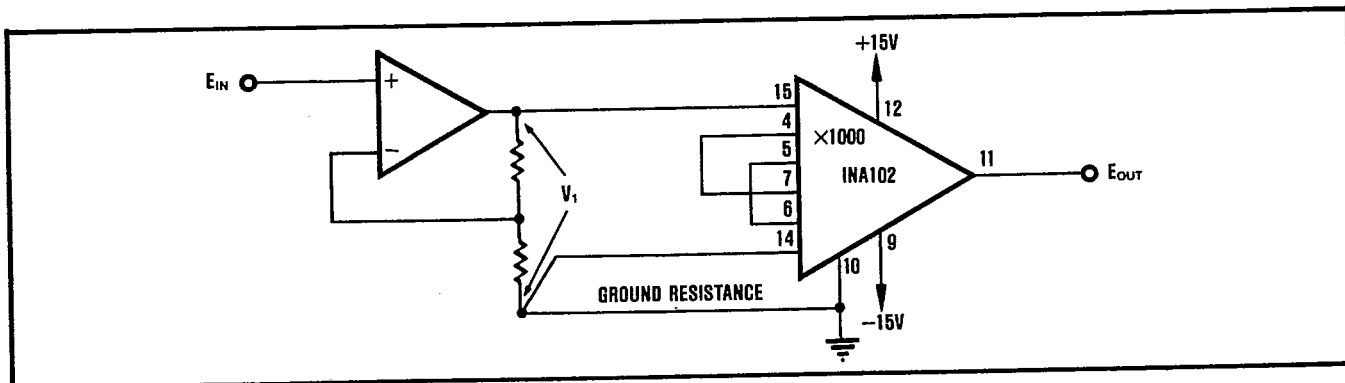

FIGURE 14. Ground Resistance Loop Eliminator (INA102 senses and amplifies V_1 accurately).

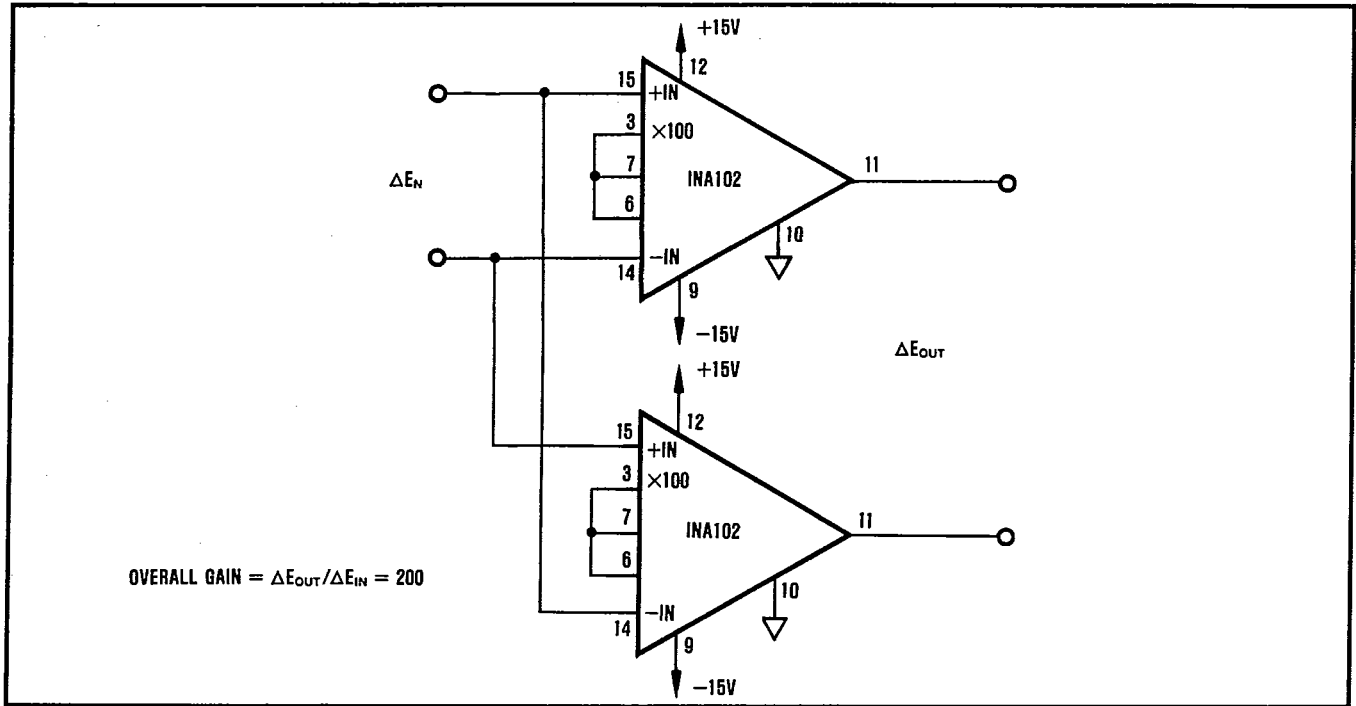

FIGURE 15. Differential Input/Differential Output Amplifier (twice the gain of one INA).

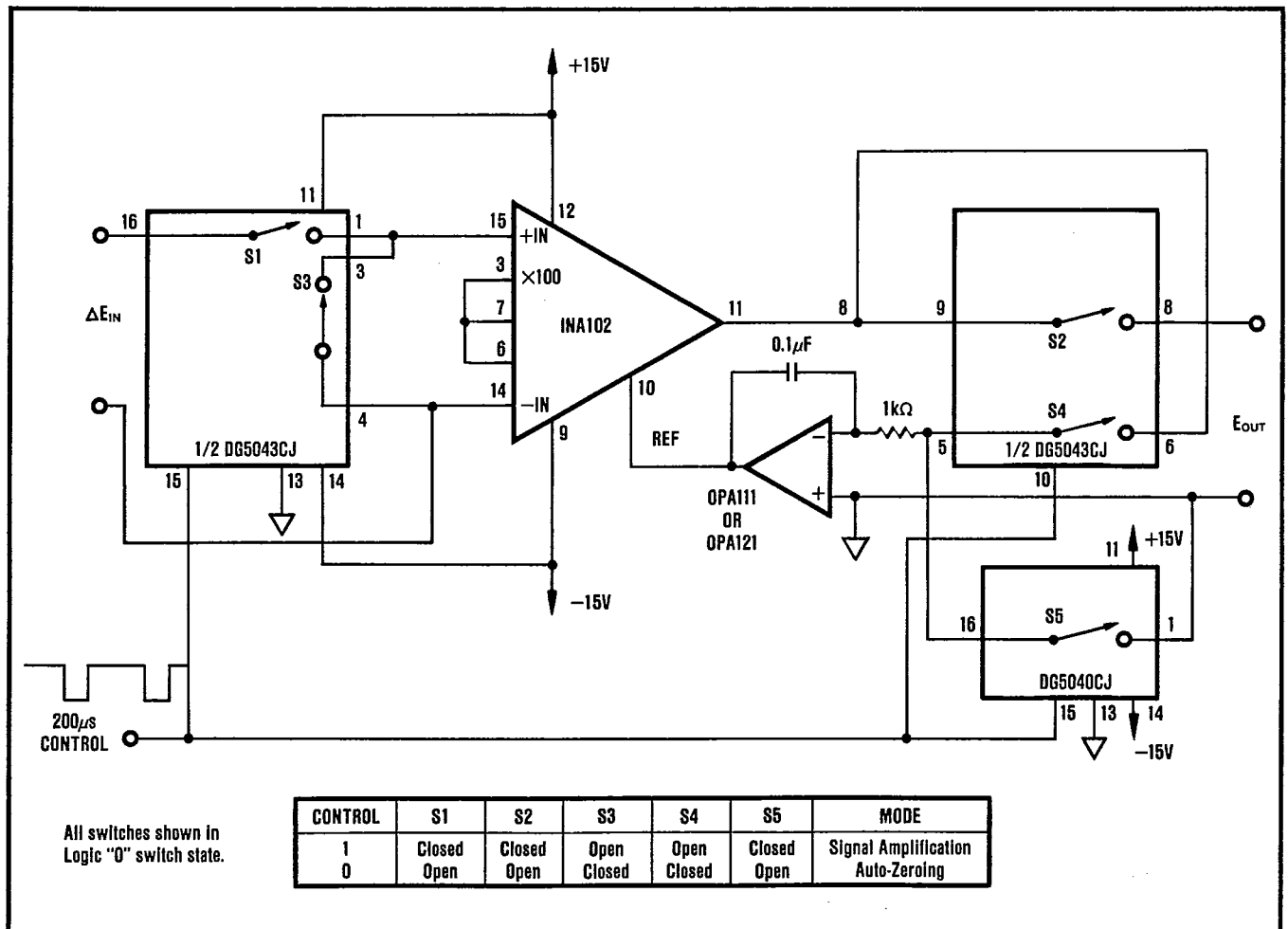

FIGURE 16. Auto-Zeroing Instrumentation Amplifier Circuit.