



68XX Microcontroller Family Compatible

64K

X68C64

8192 x 8 Bit

E² Micro-Peripheral

FEATURES

- **CONCURRENT READ WRITE™**
 - Dual Plane Architecture
 - Isolates Read/Write Functions Between Planes
 - Allows Continuous Execution of Code From One Plane While Writing in the Other Plane
- **Multiplexed Address/Data Bus**
 - Direct Interface to Popular 8-bit Microcontrollers, e.g., Motorola M6801/03, M68HC11 Family
- **High Performance CMOS**
 - Fast Access Time, 120ns
 - Low Power
 - 60mA Maximum Active
 - 500µA Maximum Standby
- **Software Data Protection**
- **Block Protect Register**
 - Individually Set Write Lock Out in 1K Blocks
- **Toggle Bit Polling**
 - Early End of Write Detection
- **Page Mode Write**
 - Allows up to 32 Bytes to be Written in One Write Cycle
- **High Reliability**
 - Endurance: 100,000 Write Cycles
 - Data Retention: 100 Years

DESCRIPTION

The X68C64 is an 8K x 8 E²PROM fabricated with advanced CMOS Textured Poly Floating Gate Technology. The X68C64 features a Multiplexed Address and Data bus allowing a direct interface to a variety of popular single-chip microcontrollers operating in expanded multiplexed mode without the need for additional interface circuitry.

The X68C64 is internally configured as two independent 4K x 8 memory arrays. This feature provides the ability to perform nonvolatile memory updates in one array and continue operation out of code stored in the other array; effectively eliminating the need for an auxiliary memory device for code storage.

To write to the X68C64, a three-byte command sequence must precede the byte(s) being written. The X68C64 also provides a second generation software data protection scheme called Block Protect. Block Protect can provide write lockout of the entire device or selected 1K blocks. There are eight 1K x 8 blocks that can be write protected individually in any combination required by the user. Block Protect, in addition to Write Control input, allows the different segments of the memory to have varying degrees of alterability in normal system operation.

5

FUNCTIONAL DIAGRAM

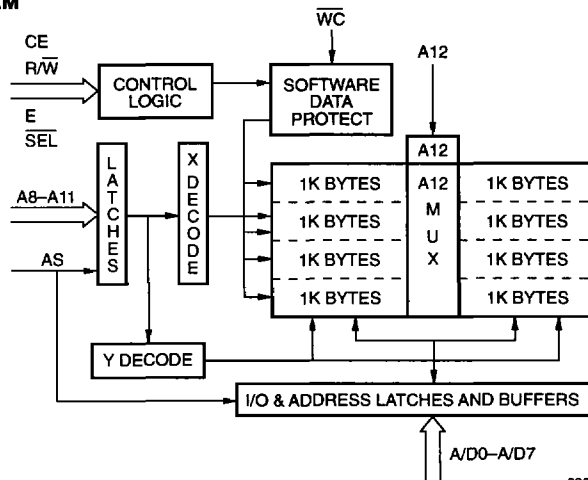

3868 FHD F02

CONCURRENT READ WRITE™ is a trademark of Xicor, Inc.

X68C64

PIN DESCRIPTIONS

Address/Data (A/D₀–A/D₇)

Multiplexed low-order addresses and data. The addresses flow into the device while AS is HIGH. After AS transitions from a HIGH to LOW the addresses are latched. Once the addresses are latched these pins input data or output data depending on E, R/W, and CE.

Addresses (A₈–A₁₂)

High order addresses flow into the device when AS is HIGH and are latched when AS goes LOW.

Chip Enable (CE)

The Chip Enable input must be HIGH to enable all read/write operations. When CE is LOW and AS is LOW, the X68C64 is placed in the low power standby mode.

Enable (E)

When used with a MC6801 or MC6803, the E input is tied directly to the E output of the microcontroller.

Read/Write (R/W)

When used with a MC6801 or MC6803, the R/W input is tied directly to the R/W output of the microcontroller.

Address Strobe (AS)

Addresses flow through the latches to address decoders when AS is HIGH and are latched when AS transitions from a HIGH to LOW.

Device Select (SEL)

Must be connected to V_{SS}.

Write Control (WC)

The Write Control allows external circuitry to abort a page load cycle once it has been initiated. This input is useful in applications in which a power failure or processor RESET could interrupt a page load cycle. In this case, the microcontroller might drive all signals HIGH, causing bad data to be latched into the E²PROM. If the Write Control input is driven HIGH (before t_{TBLC} Max) after Read/Write (R/W) goes HIGH, the write cycle will be aborted.

When WC is LOW (tied to V_{SS}) the X68C64 will be enabled to perform write operations. When WC is HIGH normal read operations may be performed, but all attempts to write to the device will be disabled.

PIN CONFIGURATION

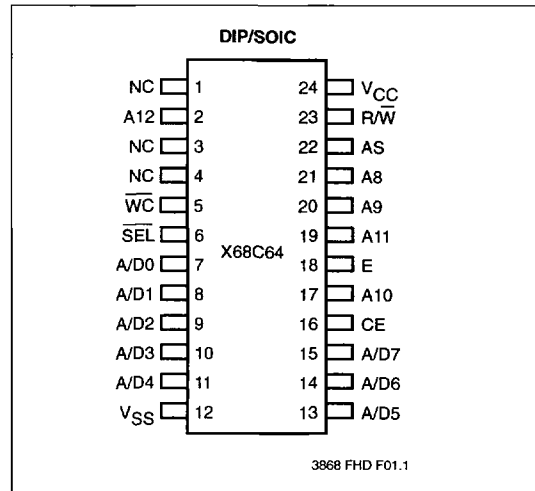

PIN NAMES

Symbol	Description
AS	Address Strobe
A/D ₀ –A/D ₇	Address Inputs/Data I/O
A ₈ –A ₁₂	Address Inputs
E	Enable Input
R/W	Read/Write Input
CE	Chip Enable
WC	Write Control
SEL	Device Select—Connect to V _{SS}
V _{SS}	Ground
V _{CC}	Supply Voltage
NC	No Connect

3868 PGM T01.1

X68C64

PRINCIPLES OF OPERATION

The X68C64 is a highly integrated peripheral device for a wide variety of single-chip microcontrollers. The X68C64 provides 8K bytes of E²PROM which can be used either for Program Storage, Data Storage, or a combination of both in systems based upon Von Neumann (68XX) architectures. The X68C64 incorporates the interface circuitry normally needed to decode the control signals and demultiplex the Address/Data bus to provide a "Seamless" interface.

The interface inputs on the X68C64 are configured such that it is possible to directly connect them to the proper interface signals of the appropriate single-chip microcontroller.

The X68C64 is internally organized as two independent planes of 4K bytes of memory with the A₁₂ input selecting which of the two planes of memory are to be accessed. While the processor is executing code out of one plane, write operations can take place in the other plane, allowing the processor to continue execution of code out of the X68C64 during a byte or page write to the device.

The X68C64 also features an advanced implementation of the Software Data Protection scheme, called Block Protect, which allows the device to be broken into 8 independent sections of 1K bytes. Each of these sections can be independently enabled for write operations; thereby allowing certain sections of the device to be secured so that updates can only occur in a controlled environment (e.g. in an automotive application, only at an authorized service center). The desired set-up configuration is stored in a nonvolatile register, ensuring the configuration data will be maintained after the device is powered down.

The X68C64 also features a Write Control input (\overline{WC}), which serves as an external control over the completion of a previously initiated page load cycle.

The X68C64 also features the industry standard E²PROM characteristics such a byte or page mode write and Toggle Bit Polling.

DEVICE OPERATION

Motorola 68XX operation requires the microcontroller's AS, E, and R/W outputs tied to the X68C64 AS, E, and R/W inputs respectively.

The falling edge of AS will latch the addresses for both a read and write operation. The state of R/W output determines the operation to be performed, with the E signal acting as a data strobe.

If R/W is HIGH and CE HIGH (read operation), data will be output on A/D₀–A/D₇ after E transitions HIGH. If R/W is LOW and CE is HIGH (write operation), data presented at A/D₀–A/D₇ will be strobed into the X68C64 on the HIGH to LOW transition of E.

Typical Application

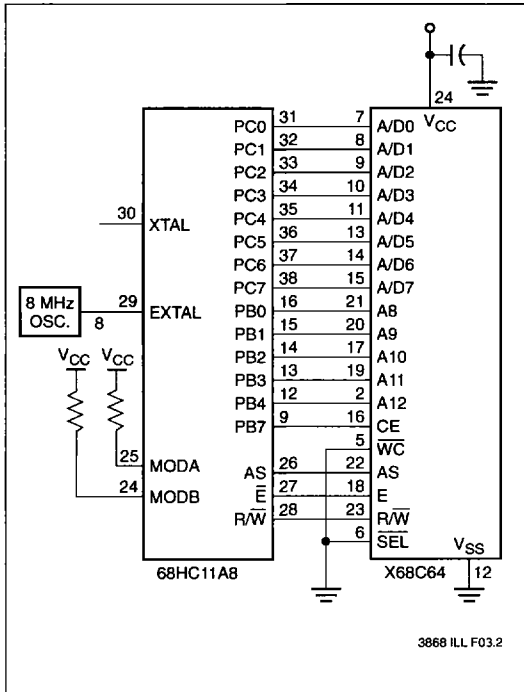

X68C64

MODE SELECTION

CE	E	R/W	Mode	I/O	Power
V _{SS}	X	X	Standby	High Z	Standby (CMOS)
LOW	X	X	Standby	High Z	Standby (TTL)
HIGH	HIGH	HIGH	Read	D _{OUT}	Active
HIGH		LOW	Write	D _{IN}	Active

3868 PGM T02.1

PAGE WRITE OPERATION

Regardless of the microcontroller employed, the X68C64 supports page mode write operations. This allows the microcontroller to write from one to thirty-two bytes of data to the X68C64. Each individual write within a page write operation must conform to the byte write timing

requirements. The rising edge of E starts a timer delaying the internal programming cycle 100μs. Therefore, each successive write operation must begin within 100μs of the last byte written. The following waveforms illustrate the sequence and timing requirements.

Page Write Timing Sequence for E Controlled Operation

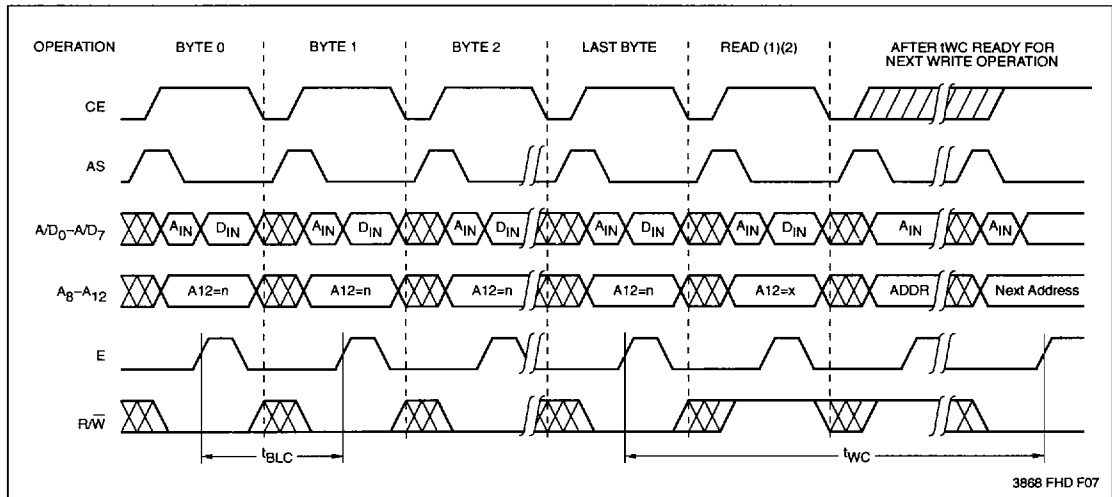

3868 FHD F07

- Notes:**
- (1) For each successive write within a page write cycle A₅-A₁₂ must be the same.
 - (2) Although it is not illustrated, the microcontroller may interleave read operations between the individual byte writes within the page write operation. Two responses are possible.
 - a. Reading from the same plane being written (A₁₂ of Read = A₁₂ of Write) is effectively a Toggle Bit Polling operation.
 - b. Reading from the opposite plane being written (A₁₂ of Read ≠ A₁₂ of Write) true data will be returned, facilitating the use of a single memory component as both program and data storage.

X68C64

Toggle Bit Polling

Because the X68C64 typical nonvolatile write cycle time is less than the specified 5ms, Toggle Bit Polling has been provided to determine the early completion of write. During the internal programming cycle, I/O₆ will toggle from HIGH to LOW and LOW to HIGH on subsequent attempts to read the device. When the internal

cycle is complete, the toggling will cease and the device will be accessible for additional read or write operations. Due to the dual plane architecture, reads for polling must occur in the plane that is being written; that is, the state of A₁₂ during a write must match the state of A₁₂ during Toggle Bit Polling.

Toggle Bit Polling E Control

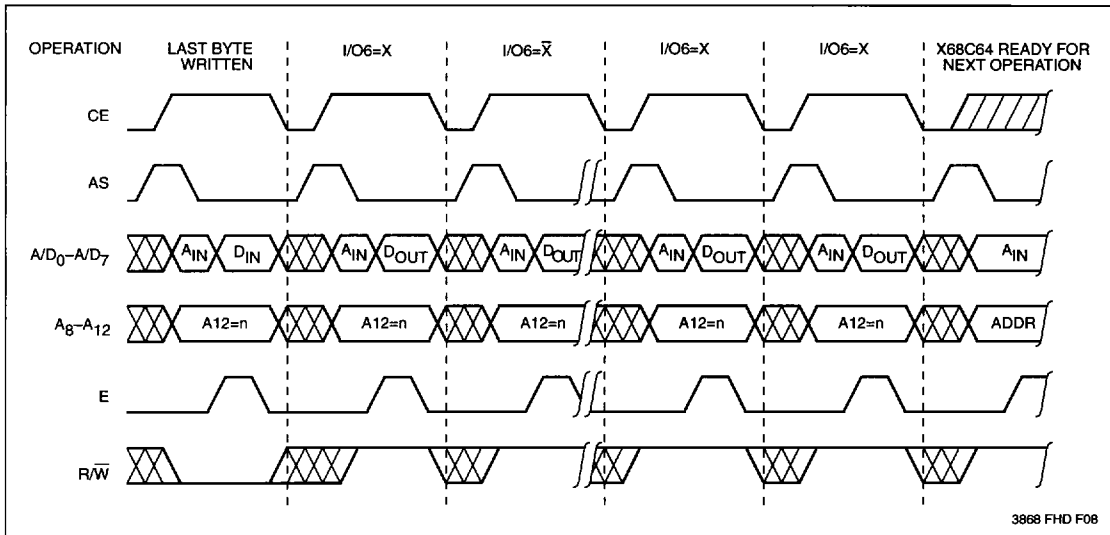

5

SYMBOL TABLE

WAVEFORM	INPUTS	OUTPUTS
	Must be steady	Will be steady
	May change from LOW to HIGH	Will change from LOW to HIGH
	May change from HIGH to LOW	Will change from HIGH to LOW
	Don't Care: Changes Allowed	Changing: State Not Known
	N/A	Center Line is High Impedance

X68C64

DATA PROTECTION

The X68C64 provides two levels of data protection through software control. There is a global software data protection feature similar to the industry standard for E²PROMs and a new Block Protect write lockout protection providing a secondary level of data security.

Writing with SDP

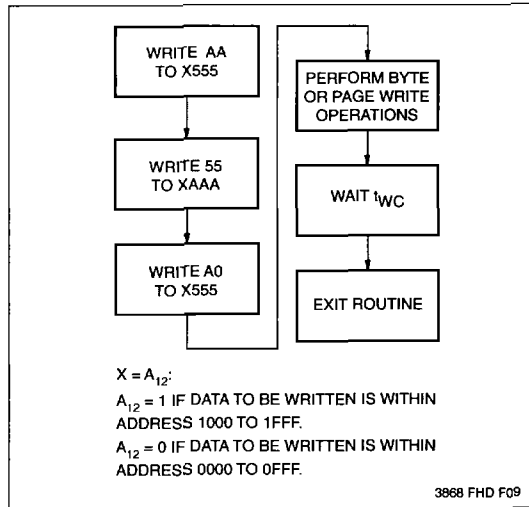

Software Data Protection

Software Data Protection (SDP) is employed to protect the entire array against inadvertent writes. To write to the X68C64, a three-byte command sequence must precede the byte(s) being written.

All write operations, both the command sequence and any data write operations, must conform to the page write timing requirements.

Block Protect Write Lockout

The X68C64 provides a secondary level of data security referred to as Block Protect write lockout. This is accessed through an extension of the SDP command sequence. Block Protect allows the user to lockout writes to any 1K x 8 blocks of memory. Unlike SDP which prevents inadvertent writes, but still allows easy system access to writing the memory, Block Protect will lockout all attempts unless it is specifically disabled by the host. This could be used to set a higher level of protection in a system where a portion of the memory is used for Program Storage and another portion is used as Data Storage.

Setting write lockout is accomplished by writing a five-byte command sequence, opening access to the Block Protect Register (BPR). After the fifth byte is written, the user writes to the BPR, selecting which blocks to protect or unprotect. All write operations, both the command sequence and writing the data to the BPR, must conform to the page write timing requirements.

Block Protect Register Format

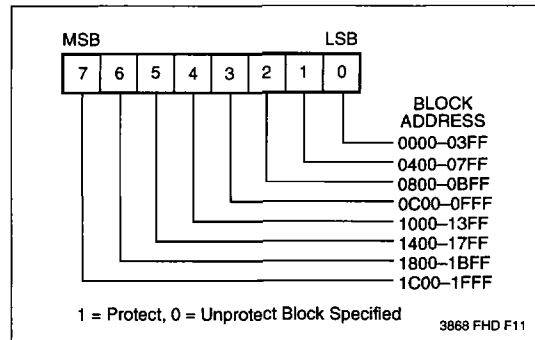

Setting BPR Command Sequence

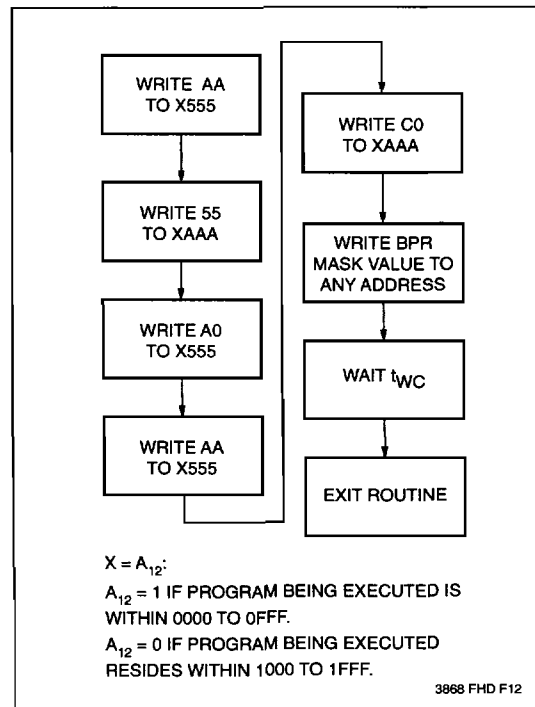

X68C64

ABSOLUTE MAXIMUM RATINGS*

Temperature under Bias	-65°C to +135°C
Storage Temperature	-65°C to +150°C
Voltage on any Pin with Respect to V _{SS}	-1V to +7V
D.C. Output Current	5mA
Lead Temperature (Soldering, 10 seconds)	300°C

*COMMENT

Stresses above those listed under "Absolute Maximum Ratings" may cause permanent damage to the device. This is a stress rating only and the functional operation of the device at these or any other conditions above those indicated in the operational sections of this specification is not implied. Exposure to absolute maximum rating conditions for extended periods may affect device reliability.

RECOMMENDED OPERATING CONDITIONS

Temperature	Min.	Max.
Commercial	0°C	+70°C
Industrial	-40°C	+85°C
Military	-55°C	+125°C

3868 PGM T03.1

Supply Voltage	Limits
X68C64	5V ±10%

3868 PGM T04.1

D.C. OPERATING CHARACTERISTICS (Over recommended operating conditions unless otherwise specified.)

Symbol	Parameter	Limits		Units	Test Conditions
		Min.	Max.		
I _{CC}	V _{CC} Current (Active)		60	mA	CE = V _{IL} , All I/O's = Open, Other Inputs = V _{CC} , AS = V _{IH}
I _{SB1} (CMOS)	V _{CC} Current (Standby)		500	μA	CE = V _{SS} , All I/O's = Open, Other Inputs = V _{CC} - 0.3V, AS = V _{SS}
I _{SB2} (TTL)	V _{CC} Current (Standby)		6	mA	CE = V _{IH} , All I/O's = Open, Other Inputs = V _{IH} , AS = V _{IL}
I _{LI}	Input Leakage Current		10	μA	V _{IN} = V _{SS} to V _{CC}
I _{LO}	Output Leakage Current		10	μA	V _{OUT} = V _{SS} to V _{CC} , E = V _{IL}
V _{IL} (1)	Input LOW Voltage	-1	0.8	V	
V _{IH} (1)	Input HIGH Voltage	2	V _{CC} + 0.5	V	
V _{OL}	Output LOW Voltage		0.4	V	I _{OL} = 2.1mA
V _{OH}	Output HIGH Voltage	2.4		V	I _{OH} = -400μA

3868 PGM T05.1

CAPACITANCE T_A = +25°C, f = 1MHz, V_{CC} = 5V

Symbol	Test	Max.	Units	Conditions
C _{I/O} (2)	Input/Output Capacitance	10	pF	V _{I/O} = 0V
C _{IN} (2)	Input Capacitance	6	pF	V _{IN} = 0V

3868 PGM T06

POWER-UP TIMING

Symbol	Parameter	Max.	Units
t _{PUR} (2)	Power-Up to Read	1	ms
t _{PUW} (2)	Power-Up to Write	5	ms

3868 PGM T07

Notes: (1) V_{IL} min. and V_{IH} max. are for reference only and are not tested.
(2) This parameter is periodically sampled and not 100% tested.

5

X68C64

A.C. CONDITIONS OF TEST

Input Pulse Levels	0V to 3V
Input Rise and Fall Times	10ns
Input and Output Timing Levels	1.5V

3868 PGM T06.1

TEST CIRCUIT

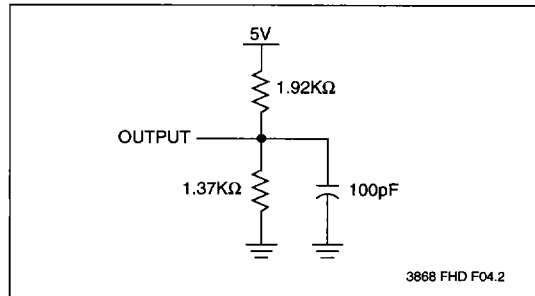

A.C. CHARACTERISTICS (Over the recommended operating conditions unless otherwise specified.)

E Controlled Read Cycle

Symbol	Parameter	Min.	Max.	Units
PW _{ASH}	Address Strobe Pulse Width	80		ns
t _{ASL}	Address Setup Time	20		ns
t _{AHL}	Address Hold Time	30		ns
t _{ACC}	Data Access Time		120	ns
t _{DHR}	Data Hold Time	0		ns
t _{CSL}	CE Setup Time	7		ns
PW _{EH}	E Pulse Width	150		ns
t _{ES}	Enable Setup Time	30		ns
t _{EH}	E Hold Time	20		ns
t _{RWS}	R/W Setup Time	20		ns
t _{HZ} ⁽³⁾	E LOW to High Z Output		50	ns
t _{LZ} ⁽³⁾	E HIGH to Low Z Output	0		ns

3868 PGM T09.1

E Controlled Read Cycle

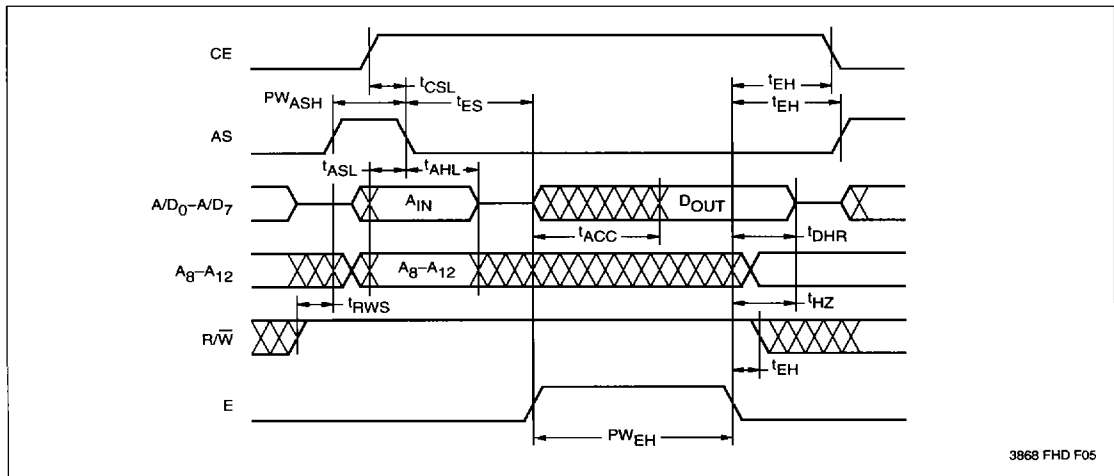

Note: (3) This parameter is periodically sampled and not 100% tested.

X68C64

E Controlled Write Cycle

Symbol	Parameter	Min.	Max.	Units
PW _{ASH}	Address Strobe Pulse Width	80		ns
t _{ASL}	Address Setup Time	20		ns
t _{AHL}	Address Hold Time	30		ns
t _{DSW}	Data Setup Time	50		ns
t _{DHW}	Data Hold Time	30		ns
t _{CSL}	CE Setup Time	7		ns
PW _{EH}	E Pulse Width	120		ns
t _{WC}	Write Cycle Time		5	ms
t _{ES}	Enable Setup Time	30		ns
t _{RWS}	R/W Setup Time	20		ns
t _{EH}	E Hold Time	20		ns
t _{BLC}	Byte Load Time (Page Write)	0.5	100	μs

3868 PGM T10

E Controlled Write Cycle

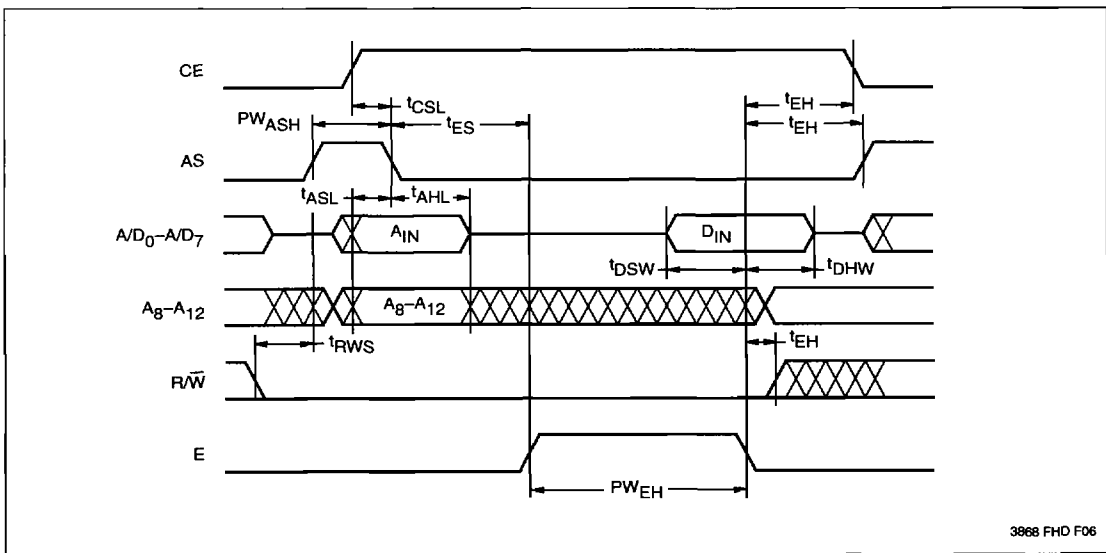

3868 FHD F06

Note: (4) t_{WC} is the minimum cycle time to be allowed from the system perspective unless polling techniques are used. It is the maximum time the device requires to automatically complete the internal write operation.

5

X68C64

ORDERING INFORMATION

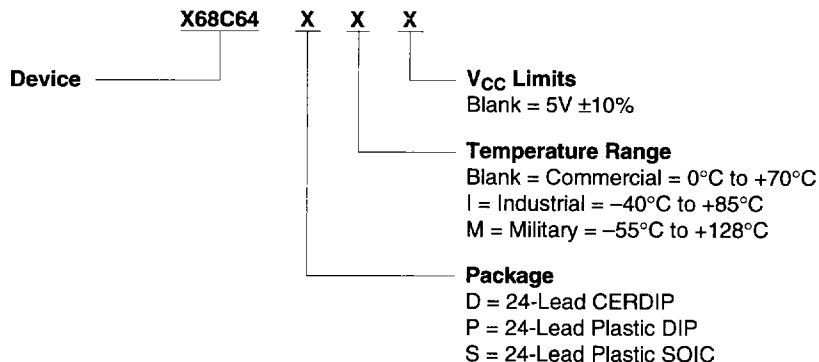

LIMITED WARRANTY

Devices sold by Xicor, Inc. are covered by the warranty and patent indemnification provisions appearing in its Terms of Sale only. Xicor, Inc. makes no warranty, express, statutory, implied, or by description regarding the information set forth herein or regarding the freedom of the described devices from patent infringement. Xicor, Inc. makes no warranty of merchantability or fitness for any purpose. Xicor, Inc. reserves the right to discontinue production and change specifications and prices at any time and without notice.

Xicor, Inc. assumes no responsibility for the use of any circuitry other than circuitry embodied in a Xicor, Inc. product. No other circuits, patents, licenses are implied.

U.S. PATENTS

Xicor products are covered by one or more of the following U.S. Patents: 4,263,664; 4,274,012; 4,300,212; 4,314,265; 4,326,134; 4,393,481; 4,404,475; 4,450,402; 4,486,769; 4,488,060; 4,520,461; 4,533,846; 4,599,706; 4,617,652; 4,688,932; 4,752,912; 4,829,482; 4,874,967; 4,883,976. Foreign patents and additional patents pending.

LIFE RELATED POLICY

In situations where semiconductor component failure may endanger life, system designers using this product should design the system with appropriate error detection and correction, redundancy and back-up features to prevent such an occurrence.

Xicor's products are not authorized for use in critical components in life support devices or systems.

1. Life support devices or systems are devices or systems which, (a) are intended for surgical implant into the body, or (b) support or sustain life, and whose failure to perform, when properly used in accordance with instructions for use provided in the labeling, can be reasonably expected to result in a significant injury to the user.
2. A critical component is any component of a life support device or system whose failure to perform can be reasonably expected to cause the failure of the life support device or system, or to affect its safety or effectiveness.