



## Advance Information

### 8-LINE TO 3-LINE PRIORITY ENCODER

The MC54/74F148 provides three bits of binary coded output representing the position of the highest order active input, along with an output indicating the presence of any active input. It is easily expanded via input and output enables to provide priority encoding over many bits.

- Encodes Eight Data Lines in Priority
- Provides 3-Bit Binary Priority Code
- Input Enable Capability
- Signals When Data Present on Any Input
- Cascadable for Priority Encoding of n Bits

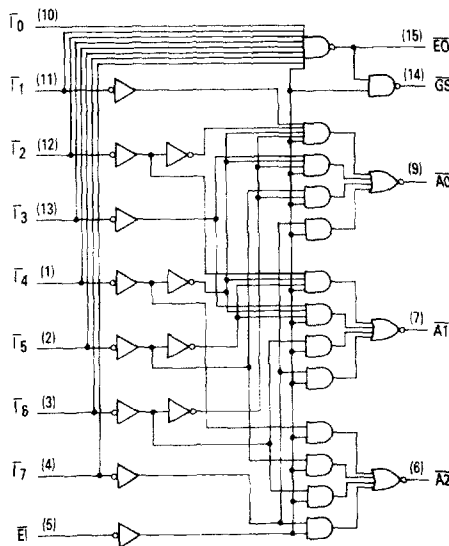

Logic Diagram

Please note that this diagram is provided only for the understanding of logic operations and should not be used to estimate propagation delays.

**MC54F148**  
**MC74F148**

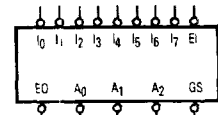

LOGIC SYMBOL



CASE 620-08



CASE 648-05



CASE 751B-01

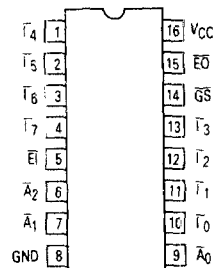

CONNECTION  
DIAGRAM

### GUARANTEED OPERATING RANGES

Symbol	Parameter		Min	Typ	Max	Unit
VCC	Supply Voltage	54, 74	4.5	5	5.5	V
TA	Operating Ambient Temperature Range	54	-55	25	125	°C
		74	0	25	70	
I <sub>OH</sub>	Output Current — High	54, 74			-1	mA
I <sub>OL</sub>	Output Current — Low	54, 74			20	mA

## FUNCTIONAL DESCRIPTION

The 'F148 8-input priority encoder accepts data from eight active LOW inputs ( $\bar{I}_0$ – $\bar{I}_7$ ) and provides a binary representation on the three active LOW outputs. A priority is assigned to each input so that when two or more inputs are simultaneously active, the input with the highest priority is represented on the output, with input line 7 having the highest priority. A HIGH on the Enable Input ( $\bar{E}$ ) will force all outputs to the inactive (HIGH) state and allow new data to settle without producing erroneous

information at the outputs. A Group Signal output ( $\bar{G}$ S) and Enable Output ( $\bar{E}$ O) are provided along with the three priority data outputs ( $\bar{A}_2$ ,  $\bar{A}_1$ ,  $\bar{A}_0$ ).  $\bar{G}$ S is active LOW when any input is LOW; this indicates when any input is active.  $\bar{E}$ O is active LOW when all inputs are HIGH. Using the Enable Output along with the Enable Input allows cascading for priority encoding on any number of input signals. Both  $\bar{E}$ O and  $\bar{G}$ S are in the inactive HIGH state when the Enable Input is HIGH.

TRUTH TABLE

$\bar{E}$	Inputs								Outputs				
	$\bar{I}_0$	$\bar{I}_1$	$\bar{I}_2$	$\bar{I}_3$	$\bar{I}_4$	$\bar{I}_5$	$\bar{I}_6$	$\bar{I}_7$	$\bar{G}$ S	$\bar{A}_0$	$\bar{A}_1$	$\bar{A}_2$	$\bar{E}$ O
H	X	X	X	X	X	X	X	X	H	H	H	H	H
L	H	H	H	H	H	H	H	H	H	H	H	H	L
L	X	X	X	X	X	X	X	L	L	L	L	L	H
L	X	X	X	X	X	X	L	H	L	H	L	L	H
L	X	X	X	X	X	L	H	H	L	L	H	L	H
L	X	X	X	L	L	H	H	H	L	H	L	L	H
L	X	X	L	H	H	H	H	H	L	H	L	H	H
L	X	L	H	H	H	H	H	H	L	L	H	H	H
L	L	H	H	H	H	H	H	H	L	H	H	H	H

H HIGH Voltage Level  
L LOW Voltage Level  
X Immaterial

4

## DC CHARACTERISTICS OVER OPERATING TEMPERATURE RANGE (unless otherwise specified)

Symbol	Parameter	Limits			Units	Test Conditions
		Min	Typ	Max		
$V_{IH}$	Input HIGH Voltage	2			V	Guaranteed Input HIGH Voltage
$V_{IL}$	Input LOW Voltage			0.8	V	Guaranteed Input LOW Voltage
$V_{IK}$	Input Clamp Diode Voltage			-1.2	V	$I_{IN} = -18$ mA $V_{CC} = \text{MIN}$
$V_{OH}$	Output HIGH Voltage	54, 74	2.5	3.4	V	$I_{OH} = 1$ mA $V_{CC} = 4.5$ V
		74	2.7	3.4	V	$I_{OH} = 1$ mA $V_{CC} = 4.75$ V
$V_{OL}$	Output LOW Voltage		0.35	0.5	V	$I_{OL} = 20$ mA $V_{CC} = \text{MIN}$
$I_{IH}$	Input HIGH Current			20	$\mu$ A	$V_{CC} = \text{MAX}$ , $V_{IN} = 2.7$ V
				100	$\mu$ A	$V_{CC} = \text{MAX}$ , $V_{IN} = 7$ V
$I_{IL}$	$\bar{I}_0, \bar{E}$			0.6	mA	$V_{CC} = \text{MAX}$ , $V_{IN} = 0.5$ V
	$\bar{I}_1$ – $\bar{I}_7$			-1.2	mA	
$I_{OS}$	Output Short Circuit Current (Note 2)	-60		-150	mA	$V_{CC} = \text{MAX}$ , $V_{OUT} = 0$ V
$I_{CC}$	Power Supply Current		23	35	mA	$V_{CC} = \text{MAX}$ , $V_{IN} = 4.5$ V

NOTES: 1. For conditions such as MIN or MAX, use the appropriate value specified under guaranteed operating ranges.  
2. Not more than one output should be shorted at a time, nor for more than 1 second.

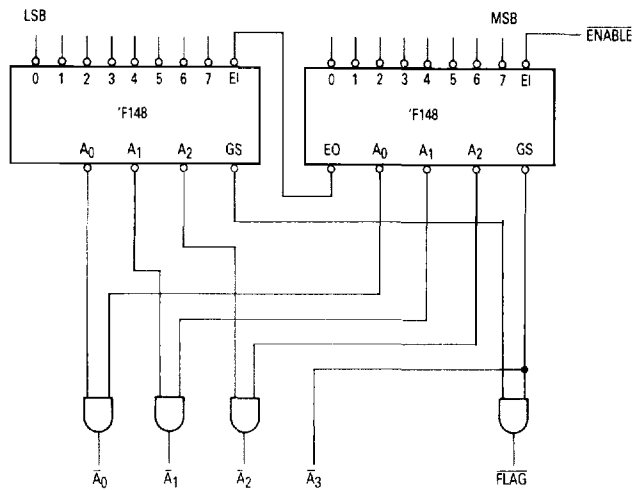

**Application**  
**16-Input Priority Encoder**

**AC CHARACTERISTICS**

Symbol	Parameter	54F/74F			54F		74F		Units
		$T_A = +25^\circ\text{C}$ $V_{CC} = +5\text{ V}$ $C_L = 50\text{ pF}$			$T_A, V_{CC} =$ Mil $C_L = 50\text{ pF}$		$T_A, V_{CC} =$ Com $C_L = 50\text{ pF}$		
		Min	Typ	Max	Min	Max	Min	Max	
$t_{PLH}$ $t_{PHL}$	Propagation Delay $I_n$ to $\bar{A}_n$	3.5 4	7	9 10.5	3.5 4	11 13	3.5 4	10 12	ns
$t_{PLH}$ $t_{PHL}$	Propagation Delay $I_n$ to EO	2.5 2	5 5.5	6.5 7.5	2.5 2	8.5 9.5	2.5 (2)	7.5 8.5	ns
$t_{PLH}$ $t_{PHL}$	Propagation Delay $I_n$ to GS	3 2	7 6	9 8	3 2	11 10	3 2	10 9	ns
$t_{PLH}$ $t_{PHL}$	Propagation Delay EI to $\bar{A}_n$	3.5 3	6.5 6	8.5 8	3.5 3	10.5 10	3.5 3	9.5 9	ns
$t_{PLH}$ $t_{PHL}$	Propagation Delay EI to GS	2.5 3	5 6	7 7.5	2.5 3	9 10	2.5 3	8 8.5	ns
$t_{PLH}$ $t_{PHL}$	Propagation Delay EI to EO	3 4.5	5.5 8	7 10.5	3 4.5	9 13	3 4.5	8 12	ns