

OCS32

Optical PNP Switches

GENERAL DESCRIPTION

The OCS32 is an optical PNP switch, combining a GaAs infrared light emitting diode and a silicon PNP photo sensor in a single 8-pin plastic package. The GaAs light emitting diode acts as the input element of the switch, activating the output photo sensor when the light emitting diode is turned on. The device is capable of withstanding high voltages. Moreover, the connection method used in the output PNP element permits bidirectional control.

The OCS32 is designed for extended life-time operation, making the device ideal for applications such as communications and telephone switching equipment.

FEATURES

- Bidirectional control
- Protection function eliminating need for power outage countermeasures
- High blocking voltage (V_{BO}): 320 V (Min.)
- Trigger input current (I_{GO}): 30 mA (Max.)
- Bidirectional 2-line control

APPLICATIONS

- Electronic automatic exchange
- Key telephone system
- Optically coupled transistor circuit

PIN CONFIGURATION

(Unit: mm)

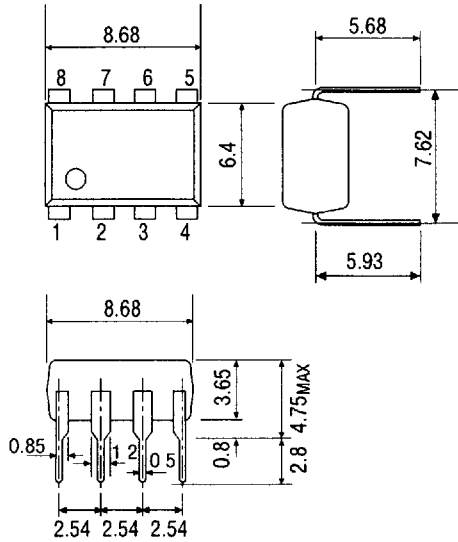

• Pin Connection Diagram

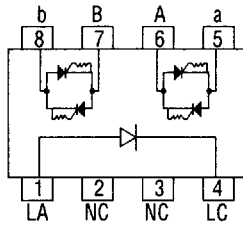

- 1: Anode (LED)
- 2: NC
- 3: NC
- 4: Cathode (LED)
- 5: Output PNP
- 6: Output PNP
- 7: Output PNP
- 8: Output PNP

ABSOLUTE MAXIMUM RATINGS

(Ambient Temperature $T_a=25^\circ\text{C}$)

	Parameter	Symbol	Rating	Unit
Input (LED)	Forward Current	I_G	60	mA
	Reverse Voltage	V_{RL}	5	V
Output (PNPN)	Forward Blocking Voltage	V_{BO}	350	V
	Continuous ON-State Current	I_F	100	mA
			150^{*1}	
	Surge ON-State Current *2	I_{SUG}	1.4	A
Isolation Breakdown Voltage		V_{I-O}	1500	V
Operating Temperature		T_{opr}	+10 to +70	$^\circ\text{C}$
Storage Temperature		T_{stg}	-30 to +100	$^\circ\text{C}$

*1 50 hour Max

*2 At pulse width 1 ms once

- Wavelength at Peak Emission

Light source : 940 nm

Photodetector: 940 nm

ELECTRICAL CHARACTERISTICS

(Ambient Temperature $T_a=25^\circ\text{C}$)

	Parameter	Symbol	Test Condition	Min.	Typ.	Max.	Unit
Input Characteristics	Forward Voltage	V_{FL}	$I_G=32\text{ mA}$	—	—	1.33	V
	Reverse Current	I_{RL}	$V_{RL}=5\text{ V}$	—	—	5	mA
Output Characteristics	OFF-State Current	I_{BO}	$V_{BO}=320\text{ V}$	—	—	5	mA
	ON-State Voltage	V_F	$I_F=20\text{ mA}$, $I_G=40\text{ mA}$	—	—	1.3	V
	dV/dt Capability	dV/dt	dt=0.1 μs	160	—	—	V/0.1 μs
	Holding Current	I_H	ON to OFF	0.12	—	1.1	mA
Coupled Characteristics	Trigger Input Current	I_{GO}	$V_{AK}=50\text{ VDC}$	—	—	30	mA

TYPICAL CHARACTERISTICS

- ON-State Current vs. ON-State Voltage ($T_a=25^\circ\text{C}$)

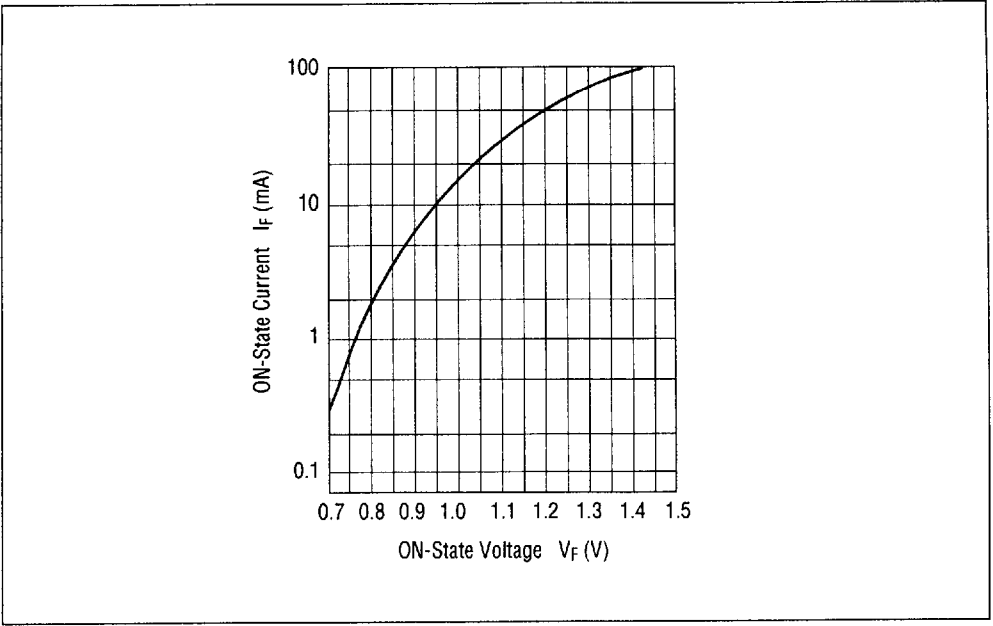

- Trigger Input Current vs. Ambient Temperature

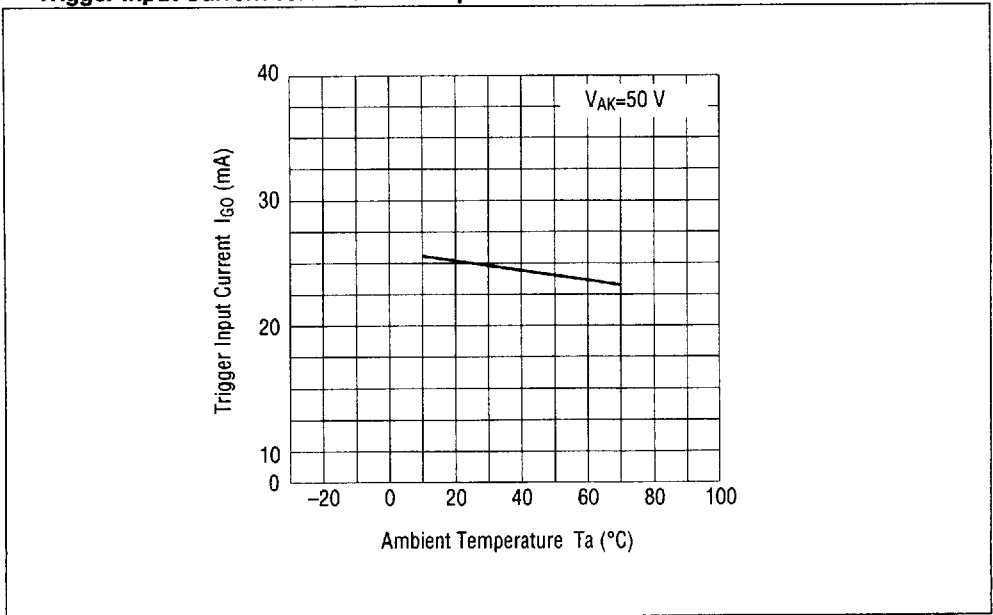

• Trigger Input Current vs. Anode-Cathode Voltage ($T_a=25^\circ\text{C}$)

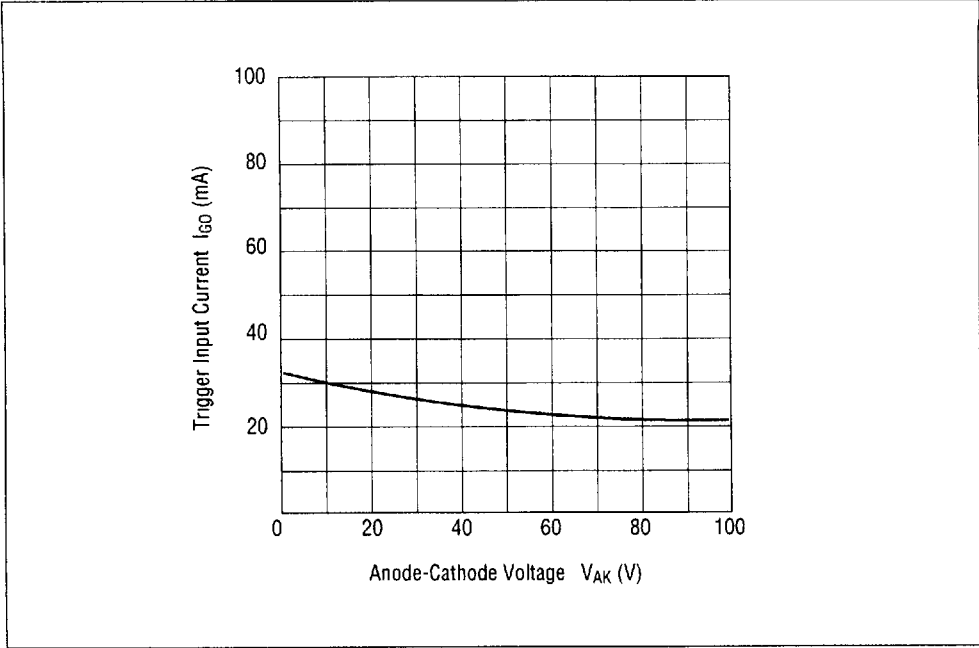

• Trigger Input Current vs. Drive Pulse Width ($T_a=25^\circ\text{C}$)

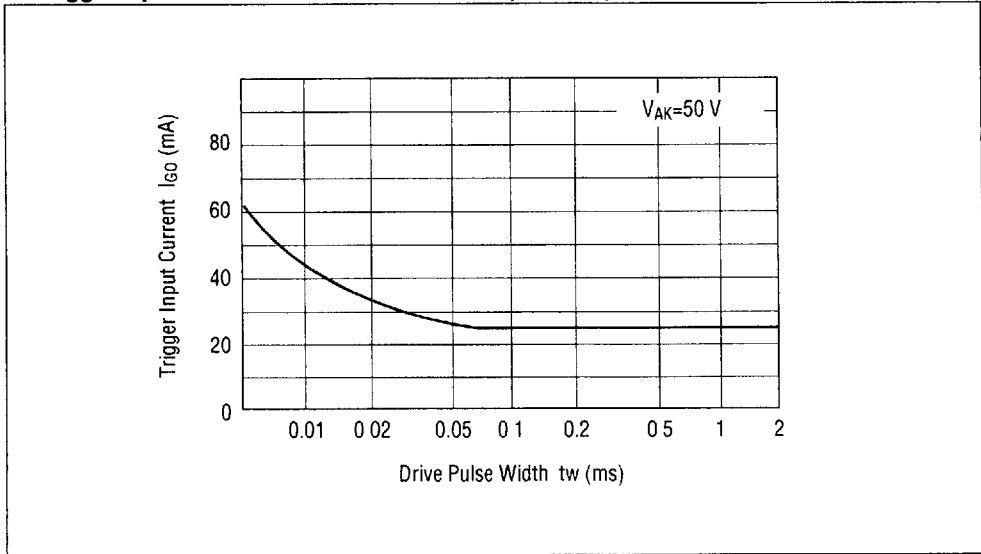

• Turn On Time vs. LED Forward Current (Ta=25°C)

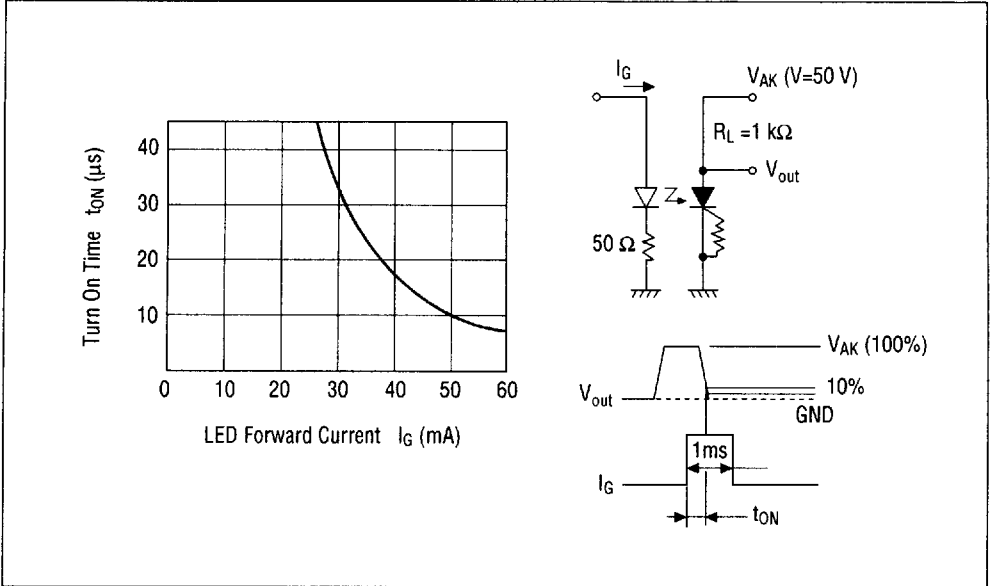

• dV/dt Capability vs. Ambient Temperature

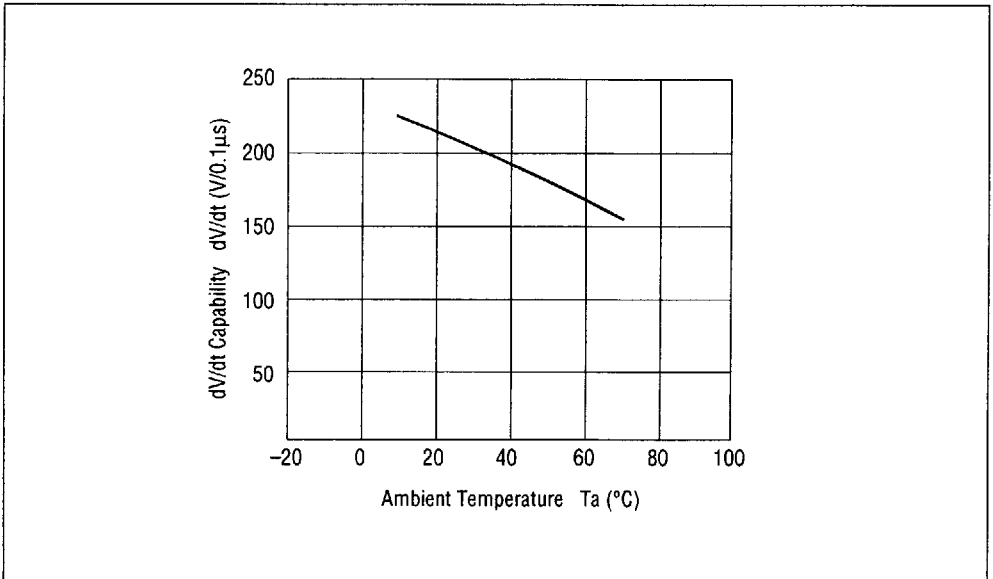

• Input LED Forward Current vs. Voltage

