



Intel® LXT974/LXT975 Fast Ethernet 10/100 Mbps Quad Transceivers

Datasheet

The Intel® LXT974 and LXT975 Fast Ethernet 10/100 Mbps Quad Transceivers (called hereafter the LXT974/975 Transceiver) are four-port PHY Fast Ethernet Transceivers, which support IEEE 802.3 physical layer applications at both 10 Mbps and 100 Mbps. They provide all of the active circuitry to interface four 802.3 Media Independent Interface (MII) compliant controllers to 10BASE-T and/or 100BASE-TX media.

This data sheet applies to all versions of the LXT974 and LXT975 products including LXT974A, LXT974B, LXT975A, and LXT975B. As a result of product changes, Revision 4 parts are labeled LXT974B and LXT975B. Revision 3 parts are labeled LXT974A and LXT975A. The differences in these product revisions are described in the LXT974/975 Specification Update.

All four ports on the LXT974 provide a combination twisted-pair (TP) or pseudo-ECL (PECL) interface for a 10/100BASE-TX or 100BASE-FX connection.

The LXT975 is pin compatible with the LXT974 except for the network ports. The LXT975 is optimized for dual-high stacked RJ-45 modular applications and provides a twisted-pair interface on every port, but the PECL interface on only two.

The LXT974/975 provides three separate LED drivers for each of the four PHY ports and a serial LED interface. In addition to standard Ethernet, each chip supports full-duplex operation at 10 Mbps and 100 Mbps. The LXT974/975 requires only a single 5V power supply. The MII may be operated independently with either a 3.3V or 5V supply.

Applications

- 10BASE-T, 10/100-TX, or 100BASE-FX Switches and multi-port NICs.
- LXT975 optimized for dual-high stacked modular RJ-45 applications.

Product Features

- Four independent IEEE 802.3-compliant 10BASE-T or 100BASE-TX ports in a single chip.
- 100BASE-FX fiber-optic capable.
- Standard CSMA/CD or full-duplex operation.
- Supports auto-negotiation and legacy systems without auto-negotiation capability.
- Baseline wander correction.
- 100BASE-TX line performance over 130 meters.
- Configurable LED drivers and serial LED output.
- Configurable through MII serial port or via external control pins.
- Available in 160-pin PQFP with heat spreader.
- Commercial temperature range (0-70°C ambient).
- Part numbers:
 - Intel® HBLXT974BHC Transceiver
 - Intel® WBLXT974BHC Transceiver (RoHS Compliant)
 - Intel® HBLXT975BHC Transceiver
 - Intel® WBLXT975BHC Transceiver (RoHS Compliant)



INFORMATION IN THIS DOCUMENT IS PROVIDED IN CONNECTION WITH INTEL® PRODUCTS. NO LICENSE, EXPRESS OR IMPLIED, BY ESTOPPEL OR OTHERWISE, TO ANY INTELLECTUAL PROPERTY RIGHTS IS GRANTED BY THIS DOCUMENT. EXCEPT AS PROVIDED IN INTEL'S TERMS AND CONDITIONS OF SALE FOR SUCH PRODUCTS, INTEL ASSUMES NO LIABILITY WHATSOEVER, AND INTEL DISCLAIMS ANY EXPRESS OR IMPLIED WARRANTY, RELATING TO SALE AND/OR USE OF INTEL PRODUCTS INCLUDING LIABILITY OR WARRANTIES RELATING TO FITNESS FOR A PARTICULAR PURPOSE, MERCHANTABILITY, OR INFRINGEMENT OF ANY PATENT, COPYRIGHT OR OTHER INTELLECTUAL PROPERTY RIGHT. Intel products are not intended for use in medical, life saving, life sustaining, critical control or safety systems, or in nuclear facility applications.

Intel may make changes to specifications and product descriptions at any time, without notice.

Intel Corporation may have patents or pending patent applications, trademarks, copyrights, or other intellectual property rights that relate to the presented subject matter. The furnishing of documents and other materials and information does not provide any license, express or implied, by estoppel or otherwise, to any such patents, trademarks, copyrights, or other intellectual property rights.

The Intel® LXT974/LXT975 Fast Ethernet 10/100 Mbps Quad Transceivers may contain design defects or errors known as errata which may cause the product to deviate from published specifications. Current characterized errata are available on request.

Contact your local Intel sales office or your distributor to obtain the latest specifications and before placing your product order.

Copies of documents which have an order number and are referenced in this document, or other Intel literature may be obtained by calling 1-800-548-4725 or by visiting Intel's website at <http://www.intel.com>.

AnyPoint, AppChoice, BoardWatch, BunnyPeople, CablePort, Celeron, Chips, CT Media, Dialogic, DM3, EtherExpress, ETOX, FlashFile, i386, i486, i960, iCOMP, InstantIP, Intel, Intel Centrino, Intel logo, Intel386, Intel486, Intel740, IntelDX2, IntelDX4, IntelSX2, Intel Create & Share, Intel GigaBlade, Intel InBusiness, Intel Inside, Intel Inside logo, Intel NetBurst, Intel NetMerge, Intel NetStructure, Intel Play, Intel Play logo, Intel SingleDriver, Intel SpeedStep, Intel StrataFlash, Intel TeamStation, Intel Xeon, Intel XScale, IPLink, Itanium, MCS, MMX, MMX logo, Optimizer logo, OverDrive, Paragon, PC Dads, PC Parents, PDCharm, Pentium, Pentium II Xeon, Pentium III Xeon, Performance at Your Command, RemoteExpress, SmartDie, Solutions960, Sound Mark, StorageExpress, The Computer Inside., The Journey Inside, TokenExpress, VoiceBrick, VTune, and Xircom are trademarks or registered trademarks of Intel Corporation or its subsidiaries in the United States and other countries.

*Other names and brands may be claimed as the property of others.

Copyright © 2006, Intel Corporation. All Rights Reserved.

Contents

1.0	Pin Assignments and Signal Descriptions	10
2.0	Functional Description	19
2.1	Introduction.....	19
2.2	Network Media / Protocol Support.....	20
2.2.1	10/100 Mbps Network Interface	20
2.2.1.1	Twisted-Pair Interface	20
2.2.1.2	Fiber Interface	21
2.2.2	MII Interface	21
2.2.2.1	MII Data Interface.....	21
2.2.2.2	MII Management Interface	24
2.2.3	Hardware Control Interface	25
2.3	Initialization.....	27
2.3.1	MDIO Control Mode	27
2.3.2	Manual Control Mode	27
2.3.3	Link Configuration	28
2.4	Auto-Negotiation.....	29
2.4.1	Parallel Detection	29
2.4.2	Controlling Auto-Negotiation	29
2.4.3	Monitoring Auto-Negotiation	29
2.5	100 Mbps Operation.....	30
2.5.1	100BASE-X MII Operations.....	30
2.5.2	100BASE-X Network Operations	30
2.5.3	100BASE-X Protocol Sublayer Operations	33
2.5.4	PCS Sublayer.....	33
2.5.4.1	Preamble Handling.....	33
2.5.4.2	Data Errors	34
2.5.4.3	Collision Indication	34
2.5.5	PMA Sublayer	35
2.5.5.1	Link.....	35
2.5.5.2	Link Failure Override	35
2.5.5.3	Carrier Sense (CRS)	35
2.5.6	Twisted-Pair PMD Sublayer	35
2.5.6.1	Scrambler/Descrambler (100TX Only)	35
2.5.6.2	Baseline Wander Correction	36
2.5.6.3	Polarity Correction	36
2.5.7	Fiber PMD Sublayer	36
2.6	10 Mbps Operation.....	36
2.6.1	10BASE-T MII Operation.....	36
2.6.2	10BASE-T Network Operations.....	36
2.6.2.1	Preamble Handling.....	37
2.6.2.2	Link Test.....	37
2.6.2.3	Link Failure	37
2.6.2.4	SQE (Heartbeat).....	37
2.6.2.5	Jabber	37
2.7	LED Functions.....	37
2.7.1	Serial LED Output	38

2.7.2	Per Port LEDs	38
2.7.2.1	LEDn_0	38
2.7.2.2	LEDn_1	38
2.7.2.3	LEDn_2	38
2.8	Operating Requirements	39
2.8.1	Power Requirements.....	39
2.8.1.1	MII Power Requirements.....	39
2.8.1.2	Low-Voltage Fault Detect.....	39
2.8.1.3	Power Down Mode	39
2.8.2	Clock Requirements.....	39
3.0	Application Information	40
3.1	Design Recommendations	40
3.1.1	General Design Guidelines	40
3.1.2	Power Supply Filtering	40
3.1.2.1	Ground Noise	41
3.1.3	Power and Ground Plane Layout Considerations	41
3.1.3.1	Chassis Ground.....	41
3.1.4	MII Terminations	41
3.1.5	The RBIAS Pin	42
3.1.6	The Twisted-Pair Interface	42
3.1.7	The Fiber Interface	42
3.2	Magnetics Information	43
3.2.1	Magnetics With Improved Return Loss Performance.....	43
3.3	Twisted-Pair/ RJ-45 Interface.....	44
4.0	Test Specifications	50
5.0	Register Definitions	63
6.0	Package Specification	73
6.1	Top Label Markings.....	74
7.0	Ordering Information	75

Figures

1	Intel® LXT974/975 Transceiver Block Diagram	9
2	LXT974 Pin Assignments	10
3	LXT975 Pin Assignments	12
4	LXT974 Switch Application	19
5	LXT975 Switch Application	20
6	MII Data Interface	22
7	Loopback Paths	24
8	Management Interface - Read Frame Structure	25
9	Management Interface - Write Frame Structure	25
10	MDIO Interrupt Signaling	25
11	Hardware Interface Mode Selection	28
12	LXT974/975 Auto-Negotiation Operation	30
13	100BASE-TX Data Flow	31
14	100BASE-TX Frame Structure	31
15	LXT974/975 Protocol Sublayers	33
16	100BASE-TX Reception with No Errors	34
17	100BASE-TX Reception with Invalid Symbol	34
18	100BASE-TX Transmission with No Errors	34
19	100BASE-TX Transmission with Collision	34
20	Typical LXT974 Twisted-Pair Single RJ-45 Modular Application	44
21	Typical LXT975 Twisted-Pair Stacked RJ-45 Modular Application	45
22	LXT974/975 Power and Ground Connections	46
23	Typical Twisted-Pair Interface and Supply Filtering	47
24	Typical Fiber Interface	48
25	Typical MII Interface	49
26	MII - 100BASE-TX Receive Timing	53
27	MII - 100BASE-TX Transmit Timing	54
28	MII - 100BASE-FX Receive Timing	55
29	MII - 100BASE-FX Transmit Timing	56
30	MII - 10BASE-T Receive Timing	57
31	MII - 10BASE-T Transmit Timing	58
32	10BASE-T SQE (Heartbeat) Timing	58
33	10BASE-T Jab and Unjab Timing	59
34	Auto Negotiation and Fast Link Pulse Timing	60
35	Fast Link Pulse Timing	60
36	MDIO Timing when Sourced by STA	61
37	MDIO Timing When Sourced by PHY	61
38	Power Down Timing	62
39	Serial LED Timing	62
40	PHY Identifier Bit Mapping	66
41	LXT974/975 Package Specification	73
42	Sample HQFP Package – Intel® HBLXT97xBHC Transceiver	74
43	Sample Pb-Free (RoHS-Compliant) HQFP Package – Intel® WBLXT97xBHC Transceiver	74
44	Ordering Information Matrix – Sample	76

Tables

1	LXT974 Signal Detect/TP Select Signal Descriptions	11
2	LXT974 Twisted-Pair Interface Signal Descriptions	11
3	LXT974 Fiber Interface Signal Descriptions.....	11
4	LXT975 Signal Detect/TP Select Signal Descriptions	13
5	LXT975 Twisted-Pair Interface Signal Descriptions	13
6	LXT975 Fiber Interface Signal Descriptions.....	13
7	LXT974 and LXT975 MII Signal Descriptions	14
8	LXT974 and LXT975 Hardware Control Interface Signal Descriptions	16
9	LXT974 and LXT975 Miscellaneous Signal Descriptions	17
10	LXT974 and LXT975 LED Indicator Signal Descriptions	17
11	LXT974 Power Supply Signal Descriptions.....	18
12	LXT975 Power Supply Signal Descriptions.....	18
13	Test Loopback Operation.....	23
14	Carrier Sense, Loopback, and Collision Conditions	24
15	Configuring the LXT974/975 via Hardware Control	26
16	Configuring LXT974/975 Auto-Negotiation Advertisements Via Hardware Control	26
17	Configuring the LXT974/975 with Auto-Negotiation Disabled	27
18	Mode Control Settings.....	28
19	4B/5B Coding	32
20	LED-DAT Serial Port Bit Assignments	39
21	Magnetics Requirements	43
22	Absolute Maximum Ratings	50
23	Operating Conditions	50
24	Digital I/O Characteristics 1.....	50
25	Digital I/O Characteristics - MII Pins)	51
26	Required CLK25M Characteristics	51
27	Low-Voltage Fault Detect Characteristics	51
28	100BASE-TX Transceiver Characteristics	51
29	100BASE-FX Transceiver Characteristics	52
30	10BASE-T Transceiver Characteristics.....	52
31	II - 100BASE-TX Receive Timing Parameters	53
32	II - 100BASE-TX Transmit Timing Parameters	54
33	II - 100BASE-FX Receive Timing Parameters	55
34	II - 100BASE-FX Transmit Timing Parameters	56
35	II - 10BASE-T Receive Timing Parameters.....	57
36	II - 10BASE-T Transmit Timing Parameters.....	58
37	10BASE-T SQE (Heartbeat) Timing Parameters	58
38	10BASE-T Jab and Unjab Timing Parameters.....	59
39	Auto Negotiation and Fast Link Pulse Timing Parameters.....	60
40	II Timing Parameters	61
41	Power Down Timing Parameters	62
42	Serial LED Timing Parameters.....	62
43	Register Set	63
44	Control Register	64
45	Status Register (Address 1)	65
46	PHY Identification Register 1 (Address 2).....	66
47	PHY Identification Register 2 (Address 3).....	66
48	Auto Negotiation Advertisement Register (Address 4).....	67



49	Auto Negotiation Link Partner Ability Register (Address 5).....	67
50	Auto Negotiation Expansion (Address 6)	68
51	LED Configuration Register (Address 16, Hex 10).....	68
52	Interrupt Enable Register (Address 17, Hex 11)	69
53	Interrupt Status Register (Address 18, Hex 12)	70
54	Port Configuration Register (Address 19, Hex 13).....	70
55	Port Status Register (Address 20, Hex 14)	71
56	QUAD FLAT PACKAGE.....	73
56	Product Information	75

Revision History

Revision	Date	Description
002	17-Jan-2005	<ul style="list-style-type: none">• Added RoHS part numbers under Product Features on page 1.• Modified Figure 2 “LXT974 Pin Assignments” on page 10.• Added Section 6.1, “Top Label Markings” on page 74.• Added Section 7.0, “Ordering Information” on page 75.
001	November 2000	Initial Release

Figure 1. Intel® LXT974/975 Transceiver Block Diagram

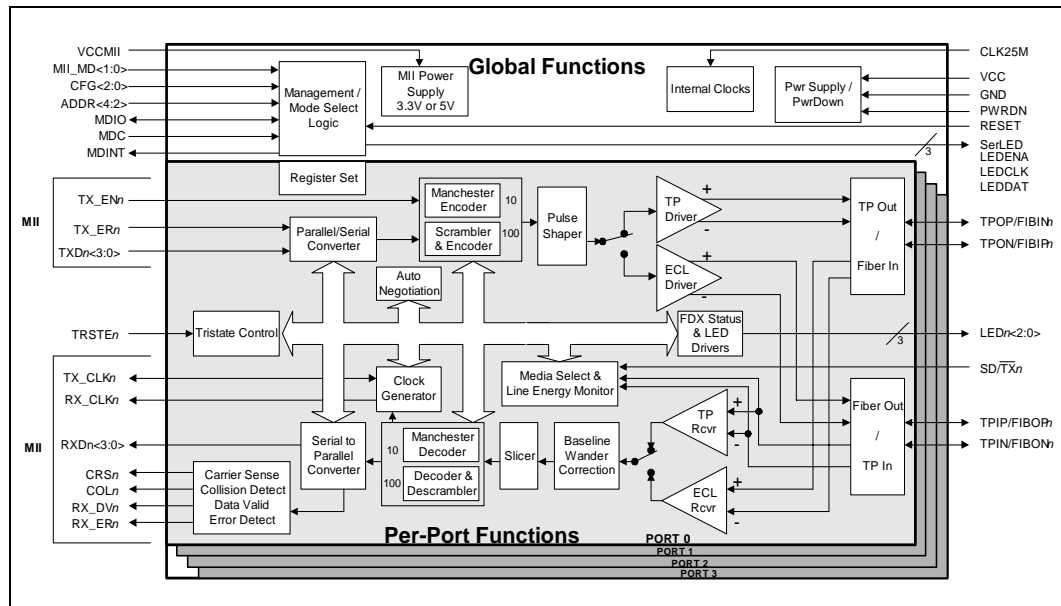

1.0 Pin Assignments and Signal Descriptions

Figure 2. LXT974 Pin Assignments

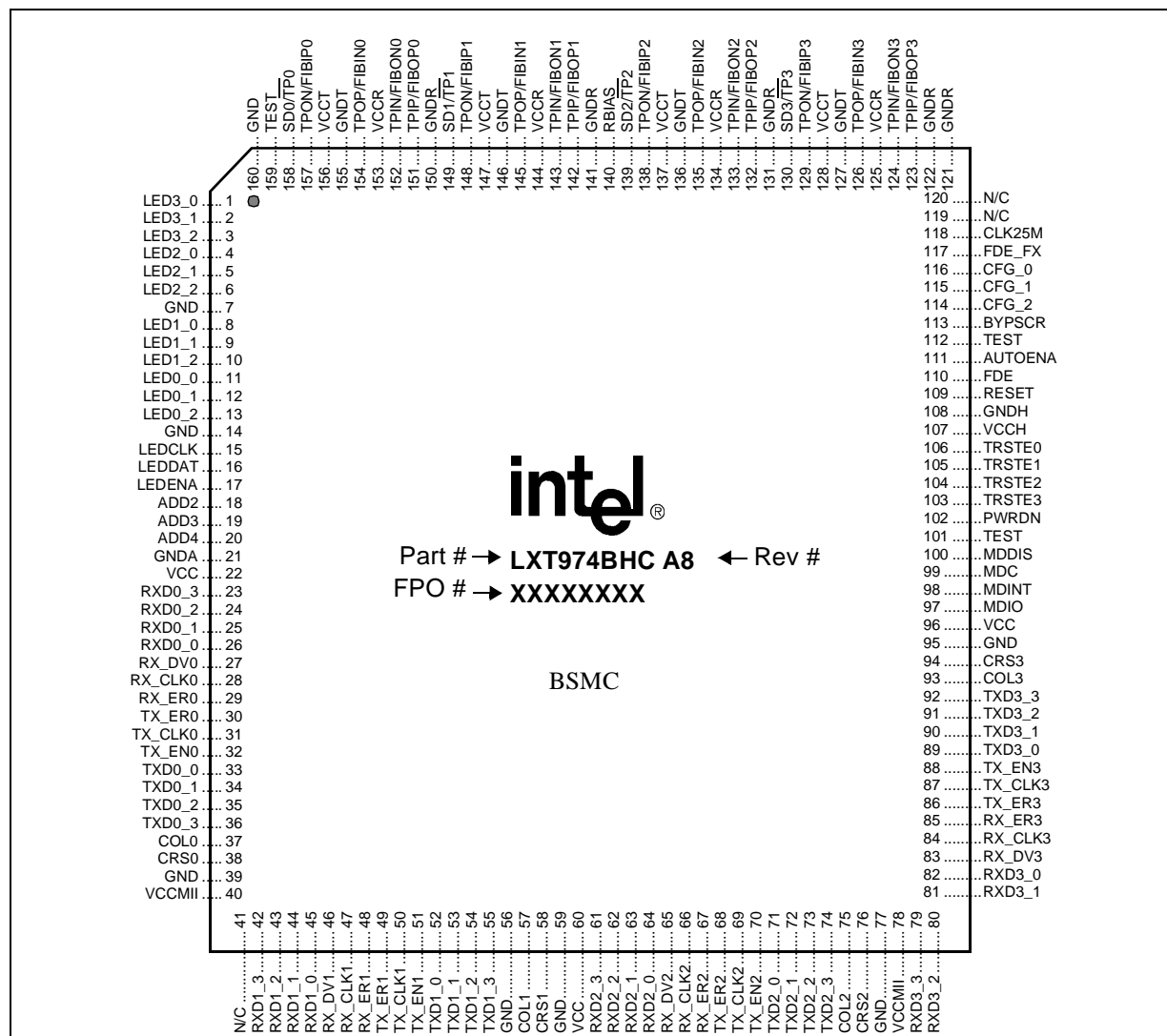

Package Topside Markings	
Marking	Definition
Part #	LXT974 is the unique identifier for this product family.
Rev #	Identifies the particular silicon "stepping" (Refer to Specification Update for additional stepping information.)
Lot #	Identifies the batch.
FPO #	Identifies the Finish Process Order.

Table 1. LXT974 Signal Detect/TP Select Signal Descriptions

Pin# ²	Symbol	Type ¹	Signal Description
158 149 139 130	SD0/ $\overline{TP0}$ SD1/ $\overline{TP1}$ SD2/ $\overline{TP2}$ SD3/ $\overline{TP3}$	I	<p>Signal Detect - Ports 0 - 3. When SD/TPn pins are tied High or to a 5V PECL input, bit 19.2 = 1 and the operating mode of each respective port is forced to FX mode. In this mode, full-duplex is set via pin 117 (FDE_FX). When not using FX mode, SD/TPn pins should be tied to GNDT.</p> <p>TP Select - Ports 0 - 3. When SD/TPn pins are tied Low, bit 19.2 = 0. The operating mode of each port can be set to 10BASE-T, 100BASE-TX, or 100BASE-FX via the hardware control interface pins as shown in Table 8 on page 16.</p> <p>Note: Hardware control interface pins (CFG_0, CFG_1, CFG_2, FDE, BYPSCR, and AUTOENA) are global and set all ports simultaneously.</p> <p>In TP mode, network pins operate as described in Table 2.</p> <p>In FX mode, network pins are re-mapped and operate as described in Table 3.</p>
<p>1. Type Column Coding: I = Input, O = Output. 2. When not using fiber mode, SD/TPn pins should be tied to GNDT.</p>			

Table 2. LXT974 Twisted-Pair Interface Signal Descriptions

Pin#	Symbol	Type ¹	Signal Description
154, 157 145, 148 135, 138 126, 129	TPO0, TPON0 TPO1, TPON1 TPO2, TPON2 TPO3, TPON3	O	<p>Twisted-Pair Outputs, Positive & Negative - Ports 0-3.</p> <p>During 100BASE-TX or 10BASE-T operation, TPO pins drive 802.3 compliant pulses onto the line.</p>
151, 152 142, 143 132, 133 123, 124	TPIP0, TPIN0 TPIP1, TPIN1 TPIP2, TPIN2 TPIP3, TPIN3	I	<p>Twisted-Pair Inputs, Positive & Negative - Ports 0-3.</p> <p>During 100BASE-TX or 10BASE-T operation, TPI pins receive differential 100BASE-TX or 10BASE-T signals from the line.</p>
<p>1. Type Column Coding: I = Input, O = Output.</p>			

Table 3. LXT974 Fiber Interface Signal Descriptions

Pin#	Symbol	Type ¹	Signal Description
154, 157 145, 148 135, 138 126, 129	FIBIN0, FIBIP0 FIBIN1, FIBIP1 FIBIN2, FIBIP2 FIBIN3, FIBIP3	I	<p>Fiber Inputs, Positive & Negative - Ports 0-3.</p> <p>During 100BASE-FX operation, FIBI pins receive differential PECL inputs from fiber transceivers.</p>
151, 152 142, 143 132, 133 123, 124	FIBOP0, FIBON0 FIBOP1, FIBON1 FIBOP2, FIBON2 FIBOP3, FIBON3	O	<p>Fiber Outputs, Positive & Negative - Ports 0-3.</p> <p>During 100BASE-FX operation, FIBO pins produce differential PECL outputs for fiber transceivers.</p>
<p>1. Type Column Coding: I = Input, O = Output.</p>			

Figure 3. LXT975 Pin Assignments

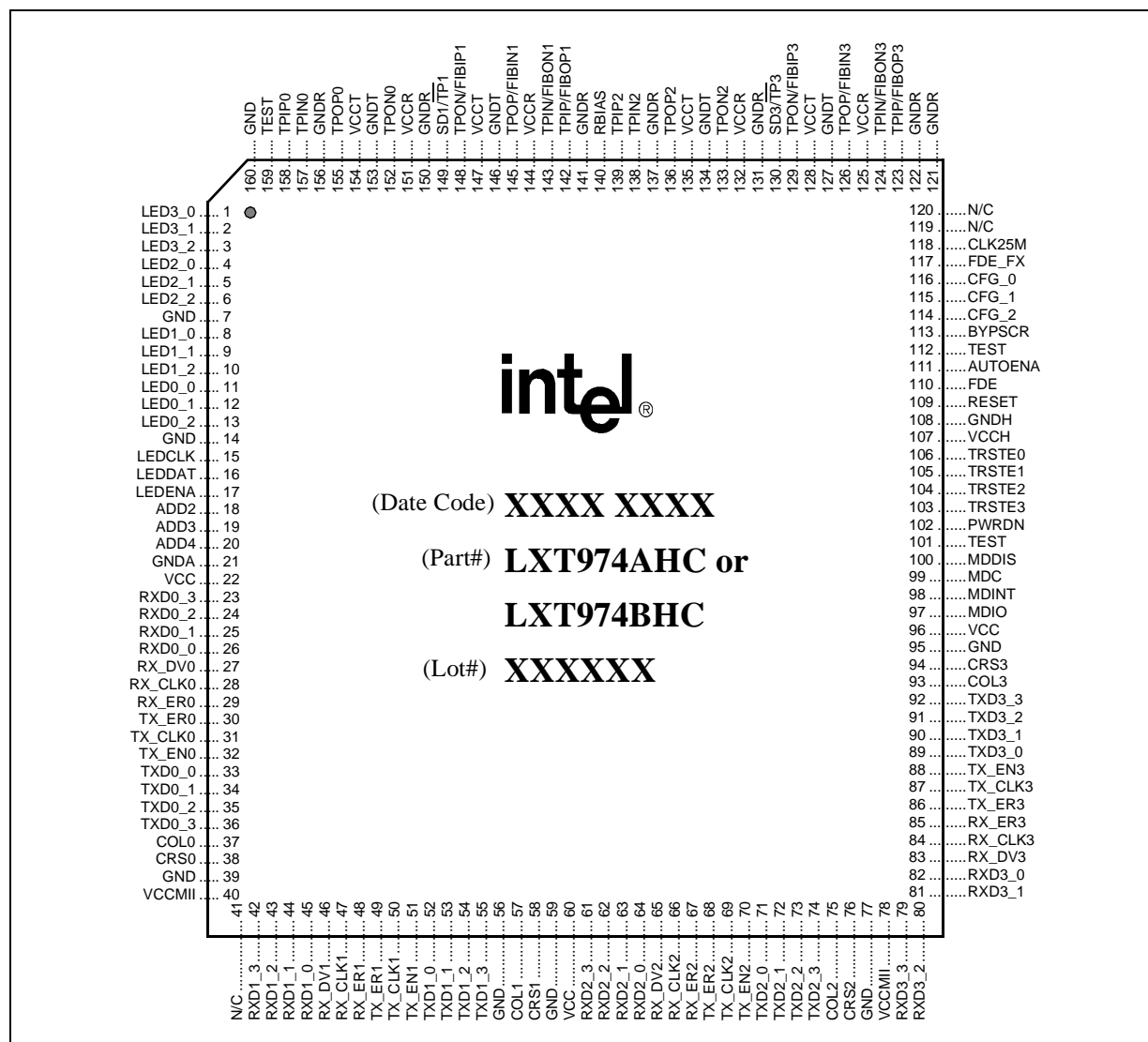

Table 4. LXT975 Signal Detect/TP Select Signal Descriptions

Pin# ²	Symbol	Type ¹	Signal Description
149 130	SD1/ $\overline{TP1}$ SD3/ $\overline{TP3}$	I	<p>Signal Detect - Ports 1 & 3. When SD/TPn pins are tied High or to a 5V PECL input, bit 19.2 = 1 and the operating mode of each respective port is forced to FX mode. In this mode, full-duplex is set via pin 117 (FDE_FX). When not using fiber mode, SD/TPn pins should be tied to GNDT.</p> <p>TP Select - Ports 1 & 3. When SD/TPn pins are tied Low, bit 19.2 = 0. The operating mode of each port can be set to 10BASE-T, 100BASE-TX, or 100BASE-FX via the hardware control interface pins as shown in Table 8 on page 16.</p> <p>Note: Hardware control interface pins (CFG_0, CFG_1, CFG_2, FDE, BYPSCR, and AUTOENA) are global and set all ports simultaneously.</p> <p>In TP mode, network pins operate as described in Table 5.</p> <p>In FX mode, network pins are re-mapped and operate as described in Table 6.</p>

1. Type Column Coding: I = Input, O = Output.
2. When not using fiber mode, SD/TP n pins should be tied to GNDT.

Table 5. LXT975 Twisted-Pair Interface Signal Descriptions

Pin#	Symbol	Type ¹	Signal Description
155, 152 145, 148 136, 133 126, 129	TPOP0, TPON0 TPOP1, TPON1 TPOP2, TPON2 TPOP3, TPON3	O	Twisted-Pair Outputs, Positive & Negative - Ports 0-3. During 100BASE-TX or 10BASE-T operation, TPO pins drive 802.3 compliant pulses onto the line.
158, 157 142, 143 139, 138 123, 124	TPIP0, TPIN0 TPIP1, TPIN1 TPIP2, TPIN2 TPIP3, TPIN3	I	Twisted-Pair Inputs, Positive & Negative - Ports 0-3. During 100BASE-TX or 10BASE-T operation, TPI pins receive differential 100BASE-TX or 10BASE-T signals from the line.

1. Type Column Coding: I = Input, O = Output.

Table 6. LXT975 Fiber Interface Signal Descriptions

Pin#	Symbol	Type ¹	Signal Description
145, 148 126, 129	FIBIN1, FIBIP1 FIBIN3, FIBIP3	I	Fiber Network Interface - Ports 1 and 3 During 100BASE-FX operation, FIBI pins receive differential PECL inputs from fiber transceivers.
142, 143 123, 124	FIBOP1, FIBON1 FIBOP3, FIBON3	O	Fiber Network Interface - Ports 1 and 3 During 100BASE-FX operation, FIBO pins produce differential PECL outputs for fiber transceivers.

1. Type Column Coding: I = Input, O = Output.

Table 7. LXT974 and LXT975 MII Signal Descriptions

Pin# ³	Symbol	Type ¹	Signal Description ²
MII Data Interface Pins			
33 34 35 36	TXD0_0 TXD0_1 TXD0_2 TXD0_3	I	Transmit Data - Port 0. Inputs containing NRZ data to be transmitted from port 0.
52 53 54 55	TXD1_0 TXD1_1 TXD1_2 TXD1_3	I	Transmit Data - Port 1. Inputs containing NRZ data to be transmitted from port 1.
71 72 73 74	TXD2_0 TXD2_1 TXD2_2 TXD2_3	I	Transmit Data - Port 2. Inputs containing NRZ data to be transmitted from port 2.
89 90 91 92	TXD3_0 TXD3_1 TXD3_2 TXD3_3	I	Transmit Data - Port 3. Inputs containing NRZ data to be transmitted from port 3.
32 51 70 88	TX_EN0 TX_EN1 TX_EN2 TX_EN3	I	Transmit Enable - Ports 0 - 3. Active High input enables respective port transmitter. This signal must be synchronous to the TX_CLK.
31 50 69 87	TX_CLK0 TX_CLK1 TX_CLK2 TX_CLK3	O	Transmit Clock - Ports 0 - 3. 25 MHz for 100 Mbps operation, 2.5 MHz for 10 Mbps operation. The transmit data and control signals must always be synchronized to TX_CLK by the MAC. The LXT974/975 normally samples these signals on the rising edge of TX_CLK. However, Advanced TX_CLK Mode is available by setting MII register bit 19.5=1. In this mode, the LXT974/975 samples the transmit data and control signals on the falling edge of TX_CLK.
30 49 68 86	TX_ER0 TX_ER1 TX_ER2 TX_ER3	I	Transmit Coding Error - Ports 0 - 3. This signal must be driven synchronously to TX_CLK. When High, forces the respective port to transmit Halt (H) code group.
26 25 24 23	RXD0_0 RXD0_1 RXD0_2 RXD0_3	O	Receive Data - Port 0. Receive data signals (4-bit parallel nibbles) are driven synchronously to RX_CLK0.
45 44 43 42	RXD1_0 RXD1_1 RXD1_2 RXD1_3	O	Receive Data - Port 1. Receive data signals (4-bit parallel nibbles) are driven synchronously to RX_CLK1.
64 63 62 61	RXD2_0 RXD2_1 RXD2_2 RXD2_3	O	Receive Data - Port 2. Receive data signals (4-bit parallel nibbles) are driven synchronously to RX_CLK2.
82 81 80 79	RXD3_0 RXD3_1 RXD3_2 RXD3_3	O	Receive Data - Port 3. Receive data signals (4-bit parallel nibbles) are driven synchronously to RX_CLK3.
<p>1. Type Column Coding: I = Input, O = Output, OD = Open Drain</p> <p>2. The LXT974/975 supports the 802.3 MDIO register set. Specific bits in the registers are referenced using an "X.Y" notation, where X is the register number (0-6 or 16-20) and Y is the bit number (0-15).</p> <p>3. Unused pins should be tied Low.</p>			

Table 7. LXT974 and LXT975 MII Signal Descriptions (Continued)

Pin# ³	Symbol	Type ¹	Signal Description ²
27 46 65 83	RX_DV0 RX_DV1 RX_DV2 RX_DV3	O	Receive Data Valid - Ports 0 - 3. These signals are synchronous to the respective RX_CLK _n . Active High indication that received code group maps to valid data.
29 48 67 85	RX_ER0 RX_ER1 RX_ER2 RX_ER3	O	Receive Error - Ports 0 - 3. These signals are synchronous to the respective RX_CLK _n . Active High indicates that received code group is invalid, or that PLL is not locked.
28 47 66 84	RX_CLK0 RX_CLK1 RX_CLK2 RX_CLK3	O	Receive Clock - Ports 0 - 3. 25 MHz for 100 Mbps and 2.5 MHz for 10 Mbps.
37 57 75 93	COL0 COL1 COL2 COL3	O	Collision Detected - Ports 0 - 3. Active High outputs asserted upon detection of a collision. Remain High for the duration of the collision. These signals are generated asynchronously. Inactive during full-duplex operation.
38 58 76 94	CRS0 CRS1 CRS2 CRS3	O	Carrier Sense - Ports 0 - 3. Active High signals. During half-duplex operation (bit 0.8 = 0), CRS _n is asserted when either transmit or receive medium is non-idle. During full-duplex operation (bit 0.8 = 1), CRS _n is asserted only when the receive medium is non-idle.
MII Control Interface Pins			
97	MDIO	I/O	Management Data Input/Output. Bidirectional serial data channel for PHY/STA communication.
98	MDINT	OD	Management Data Interrupt. An active Low output on this pin indicates status change. Interrupt is cleared by sequentially reading Register 1, then Register 18.
99	MDC	I	Management Data Clock. Clock for the MDIO serial data channel. Maximum frequency is 2.5 MHz.
100	MDDIS	I	Management Disable. When MDDIS is High, the MDIO is restricted to Read Only and the Hardware Control Interface pins provide continual control of their respective bits. When MDDIS is Low at power up or Reset, the Hardware Control Interface pins control only the initial or “default” values of their respective register bits. After the power-up/reset cycle is complete, bit control reverts to the MDIO serial channel.
106 105 104 103	TRSTE0 TRSTE1 TRSTE2 TRSTE3	I	Tristate - Ports 0 - 3. This bit controls bit 0.10 (Isolate bit). When TRSTE _n is High, the respective port isolates itself from the MII Data Interface. When MDDIS is High, TRSTE provides continuous control over bit 0.10. When MDDIS is Low, TRSTE sets the initial (default) value of bit 0.10 at Reset and then bit control reverts back to the MDIO interface.
<p>1. Type Column Coding: I = Input, O = Output, OD = Open Drain</p> <p>2. The LXT974/975 supports the 802.3 MDIO register set. Specific bits in the registers are referenced using an “X.Y” notation, where X is the register number (0-6 or 16-20) and Y is the bit number (0-15).</p> <p>3. Unused pins should be tied Low.</p>			

Table 8. LXT974 and LXT975 Hardware Control Interface Signal Descriptions

Pin#	Symbol	Type ¹	Signal Description ²
116	CFG_0 (Global)	I	<p>Configuration Control 0.</p> <p>When A/N is enabled, Low to High transition on CFG_0 causes auto-negotiate to restart on all ports and 0.9 = 1.</p> <p>When A/N is disabled, this input selects operating speed and directly affects bit 0.13. When CFG_0 is High, 100 Mbps is selected and bit 0.13 = 1. When CFG_0 is Low, 10 Mbps is selected and bit 0.13 = 0.</p>
115	CFG_1 (Global)	I	<p>Configuration Control 1.</p> <p>When A/N is enabled, CFG_1 determines operating speed advertisement capabilities in combination with CFG_2 and FDE on all ports. See Table 16 on page 26 for details.</p> <p>When A/N is disabled, CFG_1 enables 10 Mbps link test and directly affects bit 19.8. When CFG_1 is High, 10 Mbps link test is disabled and bit 19.8 = 1. When CFG_1 is Low, 10 Mbps link test is enabled and bit 19.8 = 0.</p>
114	CFG_2 (Global)	I	<p>Configuration Control 2.</p> <p>When A/N is enabled, CFG_2 determines operating speed advertisement capabilities in combination with CFG_1 on all ports. See Table 16 on page 26 for details.</p> <p>When A/N is disabled, this input selects either TP or FX interface. When FX interface is selected, the LXT974/975 automatically disables the scrambler. For correct FX operation, 100 Mbps operation must also be selected.</p> <p>Note: It is recommended to set the network interface for each port independently, via the SD/TP_n pins. See Table 1 and Table 4 for Signal Detect / TP Select signal descriptions and operation.</p> <p>When CFG_2 is Low, TP is enabled and bit 19.2 = 0. When CFG_2 is High, FX is enabled and bit 19.2 = 1.</p>
110	FDE (Global)	I	<p>Full-Duplex Enable - All Ports.</p> <p>When High, enables full-duplex operation on all ports.</p>
117	FDE_FX	I	<p>Full-Duplex Enable - FX Ports only.</p> <p>When High, enables full-duplex operation on all ports set for FX mode operation. This pin is ignored on ports set for TP mode.</p>
113	BYPSCR (Global)	I	<p>Bypass Scrambler.</p> <p>In TP mode, enables or bypasses Scrambler operation and directly affects MDIO register bit 19.3.</p> <p>When High, Scrambler is bypassed and bit 19.3 = 1. When Low, Scrambler is enabled and bit 19.3 = 0.</p> <p>In FX mode, the LXT974/975 <i>automatically</i> bypasses the Scrambler. This pin has no effect selecting Scrambler bypass.</p>
111	AUTOENA (Global)	I	<p>Auto-Negotiation Enable. When High, enables auto-negotiation on all ports.</p>

1. Type Column Coding: I = Input, O = Output, OD = Open Drain.
2. The LXT974/975 supports the 802.3 MDIO register set. Specific bits in the registers are referenced using an "X.Y" notation, where X is the register number (0-6 or 16-20) and Y is the bit number (0-15).

Table 9. LXT974 and LXT975 Miscellaneous Signal Descriptions

Pin#	Symbol	Type ¹	Signal Description ²		
			ADD1	ADD0	Port
20 19 18	ADD4 ADD3 ADD2	I I I	Address <4:2> . Set upper three bits of PHY address. ADD<1:0> are set internally to match port number as shown at right.		
			0	0	0
			0	1	1
			1	0	2
			1	1	3
101, 112, 159	TEST	I	Test . Must be tied Low.		
140	RBIAS	I	Bias . This pin provides bias current for the internal circuitry. Must be tied to ground through a 22 k Ω resistor.		
118	CLK25M	I	Clock Input . A 25 MHz clock input is required at this pin. Refer to Functional Description for detailed clock requirements.		
109	RESET	I	Reset . This active Low input is OR'ed with the control register Reset bit (0.15). The LXT974/975 reset cycle is extended 205 μ s (nominal) after Reset is de-asserted.		
102	PWRDN	I	Power Down . When High, forces LXT974/975 into power down mode. This pin is OR'ed with the Power Down bit (0.11). Refer to Table 44 on page 64 for more information.		
41, 119, 120	N/C	-	No Connection . Leave open.		

1. Type Column Coding: I = Input, O = Output, A = Analog.
2. The LXT974/975 supports the 802.3 MDIO register set. Specific bits in the registers are referenced using an "X.Y" notation, where X is the register number (0-6 or 16-20) and Y is the bit number (0-15).

Table 10. LXT974 and LXT975 LED Indicator Signal Descriptions

Pin# ²	Symbol	Type ¹	Signal Description ³
11 8 4 1	LED0_0 LED1_0 LED2_0 LED3_0	OD	LED0 - Ports 0 - 3 . In default mode, active Low output indicates transmitter active. However, LED0 is programmable and may also be set to indicate receiver active, link status or duplex status. Refer to LED Configuration Register, Table 51 on page 68 , for details on programming options.
12 9 5 2	LED0_1 LED1_1 LED2_1 LED3_1	OD	LED1 - Ports 0 - 3 . In default mode, active Low output indicates receiver active. However, LED1 is programmable and may also be set to indicate link status, duplex status, or operating speed. Refer to LED Configuration Register, Table 51 on page 68 , for details on programming options.
13 10 6 3	LED0_2 LED1_2 LED2_2 LED3_2	OD	LED2 - Ports 0 - 3 . In default mode, active Low output indicates link up. However, LED2 is programmable and may also be set to indicate duplex status, operating speed or collision. Refer to LED Configuration Register, Table 51 on page 68 , for details on programming options.
17	LEDENA	O	LED Enable . Active High output signals external device that LEDDAT is active.
15	LEDCLK	O	LED Clock . 25 MHz clock for LED serial data output.
16	LEDDAT	O	LED Data . Serial data output for 24 LEDs (6 x 4 ports) data.

1. Type Column Coding: I = Input, O = Output, OD = Open Drain.
2. Unused pins should be tied Low.
3. The LXT974/975 supports the 802.3 MDIO register set. Specific bits in the registers are referenced using an "X.Y" notation, where X is the register number (0-6 or 16-20) and Y is the bit number (0-15).

Table 11. LXT974 Power Supply Signal Descriptions

Pin#	Symbol	Type	Signal Description
22, 60, 96	VCC	-	Power Supply. +5V supply for all digital circuits.
40, 78	VCCMII	-	MII Supply. +3.3V or +5V supply for MII. A decoupling capacitor to digital ground should be supplied for these pins.
7, 14, 39, 56, 59, 77, 95, 160	GND	-	Digital Ground. Ground return for digital supply.
21	GND A	-	Analog Ground. Ground return for analog supply.
108	GNDH	-	Ground. Ground return for core analog circuitry.
107	VCCH	-	Supply. +5V supply for core analog circuitry.
128, 137, 147, 156	VCCT	-	Transmit Power Supply. +5V supply for transmit circuits.
127, 136, 146, 155	GNDT	-	Transmit Ground. Ground return for transmit supply.
125, 134, 144, 153,	VCCR	-	Receive Power Supply. +5V supply for all receive circuits.
121, 122, 131, 141, 150	GNDR	-	Receive Ground. Ground return for receive supply.

Table 12. LXT975 Power Supply Signal Descriptions

Pin#	Symbol	Type	Signal Description
22, 60, 96	VCC	-	Power Supply. +5V supply for all digital circuits.
40, 78	VCCMII	-	MII Supply. +3.3V or +5V supply for MII. A decoupling capacitor to digital ground should be supplied for these pins.
7, 14, 39, 56, 59, 77, 95, 160	GND	-	Digital Ground. Ground return for digital supply.
21	GND A	-	Analog Ground. Ground return for analog supply.
108	GNDH	-	Ground. Ground return for core analog circuitry.
107	VCCH	-	Supply. +5V supply for core analog circuitry.
128, 135, 147, 154	VCCT	-	Transmit Power Supply. +5V supply for transmit circuits.
127, 134, 146, 153	GNDT	-	Transmit Ground. Ground return for transmit supply.
125, 132, 144, 151,	VCCR	-	Receive Power Supply. +5V supply for all receive circuits.
121, 122, 131, 137, 141, 150, 156	GNDR	-	Receive Ground. Ground return for receive supply.

2.0 Functional Description

2.1 Introduction

The LXT974 and LXT975 are four-port Fast Ethernet 10/100 Transceivers that support 10 Mbps and 100 Mbps networks. They comply with all applicable requirements of IEEE 802.3. Each port can directly drive either a 100BASE-TX line (>130 meters) or a 10BASE-T line (>185 meters). [Figure 4](#) shows the LXT974 in a typical switch application.

Figure 4. LXT974 Switch Application

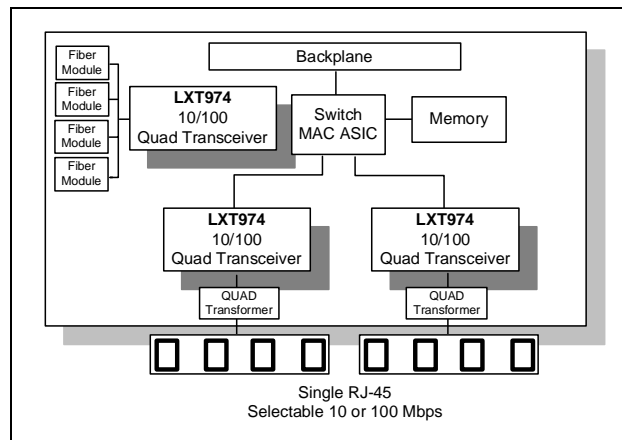

On power-up, the LXT974/975 uses auto-negotiation/parallel detection on each port to automatically determine line operating conditions. If the PHY device on the other side of the link supports auto-negotiation, the LXT974/975 auto-negotiates with it using Fast Link Pulse (FLP) Bursts. If the PHY partner does not support auto-negotiation, the LXT974/975 automatically detects the presence of either link pulses (10 Mbps PHY) or Idle symbols (100 Mbps PHY) and set its operating conditions accordingly.

The LXT974/975 interfaces to four 10/100 Media Access Controllers (MAC)s through the MII interfaces. It performs all functions of the Physical Coding Sublayer (PCS) and Physical Media Attachment (PMA) sublayer as defined in the IEEE 802.3 100BASE-X specification. This device also performs all functions of the Physical Media Dependent (PMD) sublayer for 100BASE-TX connections. The MII speeds are automatically set once port operating conditions have been determined.

The LXT974/975 provides half-duplex and full-duplex operation at 100 Mbps and 10 Mbps. It also offers standard Loopback Mode for switch applications. The LXT974/975 supports the 802.3 MDIO register set. Specific bits in the registers are referenced using an “X.Y” notation, where X is the register number (0-6 or 16-20) and Y is the bit number (0-15).

The LXT975 is pin compatible with the LXT974 except for the network ports. Each port on the LXT974 provides a combination twisted-pair or PECL interface for a 10/100BASE-TX or 100BASE-FX connection.

The LXT975 is optimized for stacked RJ-45 modular applications as shown in [Figure 5](#). Ports 1 and 3 support the PECL interface for fiber connections and all four ports support the twisted-pair interface for 10/100BASE-TX connections.

Figure 5. LXT975 Switch Application

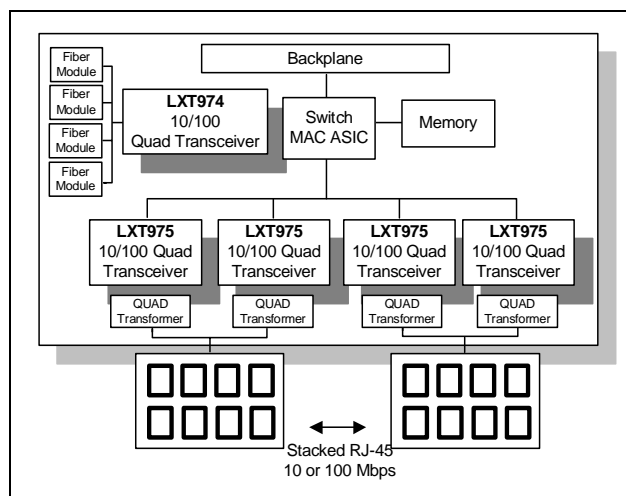

2.2 Network Media / Protocol Support

The LXT974/975 supports both 10BASE-T and 100BASE-TX Ethernet over twisted-pair, or 100 Mbps Ethernet over fiber media (100BASE-FX). A Media Independent Interface (MII) is used for communication with the Media Access Controller (MAC).

2.2.1 10/100 Mbps Network Interface

Each of the four network interface ports consists of four external pins (two differential signal pairs). The pins are shared between twisted-pair (TP) and fiber. Signal assignments (input or output, positive or negative) vary depending on whether the port is configured for TP or fiber media. Refer to [Table 1](#) through [Table 6](#) for specific pin assignments.

The LXT974/975 output drivers generate either 100BASE-TX, 10BASE-T, or 100BASE-FX output. When not transmitting data, the LXT974/975 generates 802.3-compliant link pulses or idle code. Input signals are decoded either as a 100BASE-TX, 100BASE-FX, or 10BASE-T input, depending on the mode selected. Auto-negotiation/parallel detection or manual control is used to determine the speed of this interface.

2.2.1.1 Twisted-Pair Interface

When operating at 100 Mbps, MLT3 symbols are continuously transmitted and received. When not transmitting data, the LXT974/975 generates “IDLE” symbols.

During 10 Mbps operation, Manchester-encoded data is exchanged. When no data is being exchanged, the line is left in an idle state.

In 100 Mbps mode, the LXT974/975 is capable of driving a 100BASE-TX connection over 100Ω, Category 5, Unshielded Twisted Pair (UTP). A 10BASE-T connection can be supported using 100Ω Category 3, UTP.

Only a transformer (1:1 on receive side, 2:1 on transmit side), load resistors, and bypass capacitors are needed to complete this interface. Using Intel's patented waveshaping technology, the transmitter pre-distorts the outgoing signal to reduce the need for external filters for EMI compliance.

A 4k Ω passive load is always present across the twisted-pair inputs. When enabled, the twisted-pair inputs are actively biased to approximately 2.8V.

2.2.1.2 Fiber Interface

The LXT974/975 provides a PECL interface that complies with the ANSI X3.166 specification. This interface is suitable for driving a fiber-optic coupler.

The twisted-pair pin assignments are remapped to support the PECL interface. The LXT974 supports both the twisted-pair and fiber interface on all four ports. The LXT975, optimized for TP operation with dual-high RJ-45 connectors, provides dual interfaces on ports 1 and 3.

During 100BASE-FX operation, the FIBI pins receive differential PECL signals and the FIBO pins produce differential PECL output signals.

Fiber ports cannot be enabled via auto-negotiation; they must be enabled via the Hardware Control Interface or MDIO registers.

2.2.2 MII Interface

The LXT974/975 supports four standard MIIs (one per port). This interface consists of a data interface and a management interface. The MII Data Interface passes data between the LXT974/975 and one or more Media Access Controllers (MACs). Separate signals are provided for transmit and receive. This interface operates at either 10 Mbps or 100 Mbps. The speed is set automatically, once the operating conditions of the network link have been determined.

Nine signals are used to pass received data to the MAC: RXD<3:0>, RX_CLK, RX_DV, RX_ER, COL and CRS. Seven signals are used to transmit data from the MAC: TXD<3:0>, TX_CLK, TX_EN, and TX_ER.

2.2.2.1 MII Data Interface

Figure 6 shows the data portion of the MII interface. Separate channels are provided for transmitting data from the MAC to the LXT974/975 (TXD), and for receiving data (RXD) from the line.

Each channel has its own clock, data bus, and control signals. The LXT974/975 supplies both clock signals as well as separate outputs for carrier sense and collision. Data transmission across the MII is implemented in 4-bit-wide nibbles.

Tristating the MII

The LXT974/975 asserts RX_DV, RXD, RX_CLK and RX_ER as soon as it receives a packet from the network. When TRSTEn is High, the associated port output signals are tristated.

Figure 6. MII Data Interface

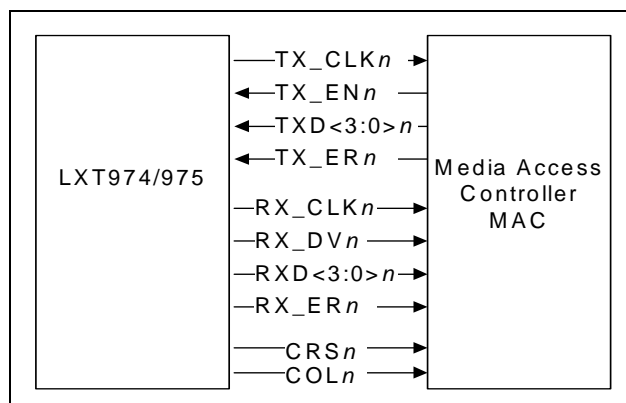

Transmit Clock

The LXT974/975 is the master clock source for data transmission. The LXT974/975 automatically sets the speed of TX_CLK to match port conditions. If the port is operating at 100 Mbps, TX_CLK is set to 25 MHz. If the port is operating at 10 Mbps, TX_CLK is set to 2.5 MHz. The transmit data and control signals must always be synchronized to TX_CLK by the MAC. The LXT974/975 normally samples these signals on the rising edge of TX_CLK.

However, Advanced TX_CLK Mode is available by setting MII register bit 19.5=1. In this mode, the LXT974/975 samples the transmit data and control signals on the falling edge of TX_CLK. When operating under MDIO Control, the user can advance the transmit clock relative to TXD<3:0> and TX_ER. When Advance TX_CLK Mode is selected, the LXT974/975 clocks TXD data in on the falling edge of TX_CLK, instead of the rising edge. This mode provides an increase in timing margins of TXD, relative to TX_CLK. Advance TX_CLK Mode is enabled when bit 19.5 = 1.

Transmit Enable

The MAC must assert TX_EN the same time as the first nibble of preamble, and de-assert TX_EN after the last bit of the packet.

Receive Data Valid

The LXT974/975 asserts RX_DV when it receives a valid packet. Timing changes depend on line operating speed:

- For 100TX and 100FX links, RX_DV is asserted from the first nibble of preamble to the last nibble of the data packet.
- For 10BT links, the entire preamble is truncated. RX_DV is asserted with the first nibble of the Start of Frame Delimiter (SFD) “5D” and remains asserted until the end of the packet.

Error Signals

Whenever the LXT974/975 receives an errored symbol from the network, it asserts RX_ER and drives “1110” on the RXD pins.

When the MAC asserts TX_ER, the LXT974/975 drives “H” symbols out on the line.

Carrier Sense

Carrier sense (CRS) is an asynchronous output. It is always generated when a packet is received from the line and in some modes when a packet is transmitted.

On transmit, CRS is asserted on a 10 Mbps or 100 Mbps half-duplex link. Carrier sense is not generated on transmit when the link is operating in full-duplex mode.

Usage of CRS for Interframe Gap (IFG) timing is *not* recommended for the following reasons:

- De-assertion time for CRS is slightly longer than assertion time. This causes IFG intervals to appear somewhat shorter to the MAC than it actually is on the wire.
- CRS de-assertion is not aligned with TX_EN de-assertion on transmit loopbacks in half-duplex mode.

Operational Loopback

Operational loopback is provided for 10 Mbps half-duplex links when bit 19.11 = 0. Data transmitted by the MAC is looped back on the receive side of the MII. Operational loopback is not provided for 100 Mbps links, full-duplex links, or when 19.11 = 1.

Test Loopback

A test loopback function is provided for diagnostic testing of the LXT974/LXT975. During test loopback, twisted-pair and fiber interfaces are disabled. Data transmitted by the MAC is internally looped back by the LXT974/975 and returned to the MAC.

Test loopback is available for 100TX, 100FX, and 10T operation. Test loopback is enabled by setting bit 0.14 = 1, bit 0.8 = 1 (full-duplex), and bit 0.12 = 0 (disable auto-negotiation). The desired mode of operation for test loopback is set using bits 0.13 and 19.2 as shown in [Table 13](#). Loopback paths for the three modes of operation are shown in [Figure 7](#).

Table 13. Test Loopback Operation

Mode of Operation	Bit	
	19.2	0.13
10T Test Loopback	0	0
100TX Test Loopback	0	1
100FX Test Loopback	1	1
1. Bit 0.14 = 1, bit 0.8 = 1, and 0.12 = 0 must also be set to enable Test Loopback.		

Figure 7. Loopback Paths

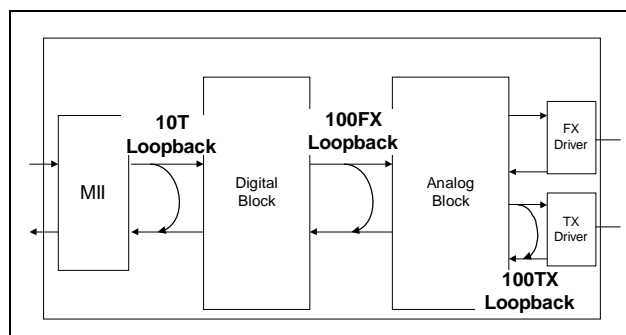

Collision

The LXT974/975 asserts its collision signal, asynchronously to any clock, whenever the line state is half-duplex and the transmitter and receiver are active at the same time. Table 14 summarizes the conditions for assertion of carrier sense, collision, and data loopback signals.

Table 14. Carrier Sense, Loopback, and Collision Conditions

Speed & Duplex Condition	Carrier Sense	Loopback	Collision
Full-Duplex at 10 Mbps or 100 Mbps	Receive Only	None	None
100 Mbps, Half-Duplex	Transmit or Receive	None	Transmit and Receive
10 Mbps, Half-Duplex, 19.11 = 0	Transmit or Receive	Yes	Transmit and Receive
10 Mbps, Half-Duplex, 19.11 = 1	Transmit or Receive	None	Transmit and Receive

2.2.2.2 MII Management Interface

The LXT974/975 supports the IEEE 802.3 MII Management Interface also known as the Management Data Input/Output (MDIO) Interface. This interface allows upper-layer devices to monitor and control the state of the LXT974/975. The MDIO interface consists of a physical connection, a specific protocol that runs across the connection, and an internal set of addressable registers. Some registers are required and their functions are defined by the IEEE 802.3 specification. Additional registers are allowed for expanded functionality. The LXT974/975 is configured with both sets of registers.

The physical interface consists of a data line (MDIO) and clock line (MDC). Operation of this interface is controlled by the MDDIS input pin. When MDDIS is High, the MDIO operates as a read-only interface. When MDDIS is Low, both read and write are enabled. The timing for the MDIO Interface is shown in Table 40 on page 61. The protocol is shown in Figure 8 and Figure 9 (read and write). The protocol allows one controller to communicate with up to eight LXT974/975 chips. Bits A4:2 of the 5-bit PHY address are assigned as the LXT974/975 address. Bits A1:0 are assigned as port addresses 0 through 3. The LXT974/975 supports 12 internal registers per port (48 total), each of which is 16 bits wide.

Figure 8. Management Interface - Read Frame Structure

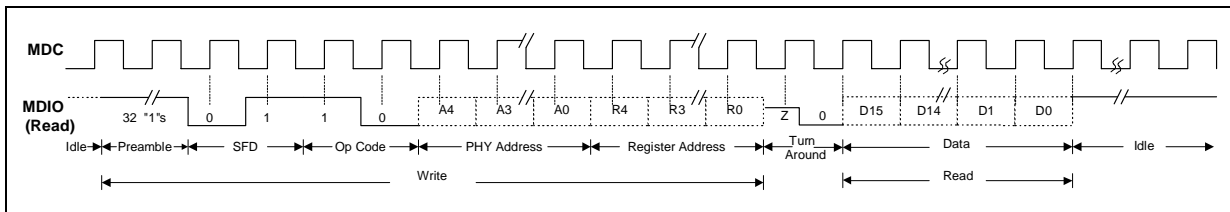
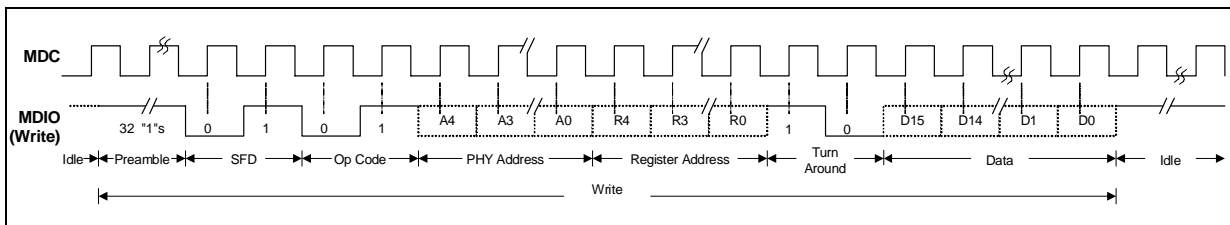

Figure 9. Management Interface - Write Frame Structure



MII Interrupts

The LXT974/975 provides interrupt signals in two ways. The MDIO interrupt reflects the interrupt status of each port addressed by the read. Details are shown in [Figure 10](#).

Setting bit 17.1 = 1 on all four ports, enables global interrupts using the MDINT pin. An active Low on this pin indicates a status change on the LXT974/975. Interrupts may be caused by:

- Link status change
- Auto-negotiation complete
- Full-duplex status change
- Jabber detect

Figure 10. MDIO Interrupt Signaling

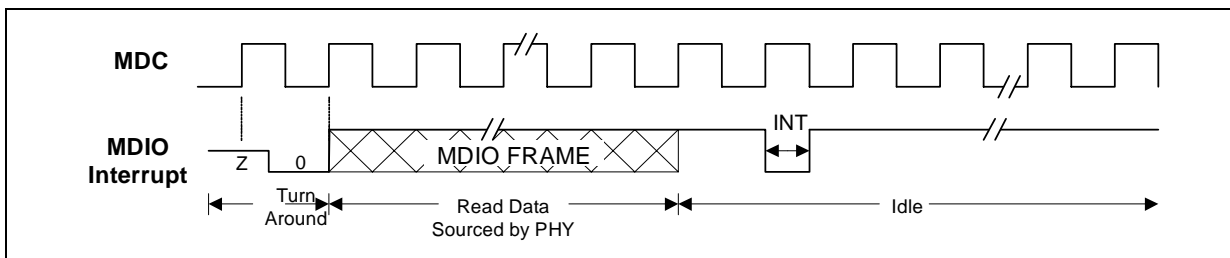

2.2.3 Hardware Control Interface

The Hardware Control Interface is used to configure operating characteristics of the LXT974/975. When MDDIS is Low, this interface provides initial values for the MDIO registers, and then passes control to the MDIO Interface. When MDDIS is High, this interface provides continuous control over the LXT974/975.

Individual chip addressing allows multiple LXT974/975 devices to share the MII in either mode. Table 15 through Table 17 show how to set up the desired operating configurations using the Hardware Control Interface.

Table 15. Configuring the LXT974/975 via Hardware Control

Desired Configuration	Pin Name	Input Value	MDIO Registers
Auto-Negotiation Enabled on all ports ^{1, 2, 3}	AUTOENA	High	0.12 = 1
	$\overline{\text{SD/TP}}_n$	Low	19.2 = 0
Auto-Negotiation Disabled on all ports ⁴	AUTOENA	Low	0.12 = 0
Scrambler Bypassed on all ports	BYPSER	High	19.3 = 1
Scrambler Enabled on all ports	BYPSER	Low	19.3 = 0

1. $\overline{\text{SD/TP}}_n$ must be set Low for Auto-Negotiation operation.
2. Refer to Table 16 for Hardware Control Interface functions advertised when auto-negotiation is enabled.
3. Fiber operation can be forced *per port* via $\overline{\text{SD/TP}}_n$ pins when auto-negotiation is enabled. See Table 17 for details.
4. Refer to Table 17 for Hardware Control Interface functions available when auto-negotiation is disabled.

Table 16. Configuring LXT974/975 Auto-Negotiation Advertisements Via Hardware Control

Desired Configuration ^{1,2}	Pin Settings					MDIO Registers			
	$\overline{\text{SD/TP}}_n$ (per port)	FDE (global)	CFG_2 (global)	CFG_1 (global)	CFG_0 ³ (global)	4.5	4.6	4.7	4.8
Advertise All	Low	Ignore	Low	Low	Ignore	1	1	1	1
Advertise 100 HD	Low	Low	High	Low	Ignore	0	0	1	0
Advertise 100 HD/FD	Low	High	High	Low	Ignore	0	0	1	1
Advertise 10 HD	Low	Low	Low	High	Ignore	1	0	0	0
Advertise 10 HD/FD	Low	High	Low	High	Ignore	1	1	0	0
Advertise 10/100 HD	Low	Low	High	High	Ignore	1	0	1	0

1. Refer to Table 15 for basic configurations.
2. Refer to Table 17 for Hardware Control Interface functions available when auto-negotiation is disabled.
3. Auto-Negotiation is not affected by CFG_0.

Table 17. Configuring the LXT974/975 with Auto-Negotiation Disabled

Desired Configuration ^{1,2}	Pin Settings					MDIO Registers		
	SD/ $\overline{TP}n$ per port	CFG_2 global	CFG_0 global	FDE global	FDE_FX	0.8	0.13	19.2
Per Port (Fiber) Configuration								
Fiber operation can be forced <i>per port</i> via SD/ $\overline{TP}n$ pins when auto-negotiation is enabled. Per-port settings override the global pin settings.								
100FX Full-Duplex Operation.	High or PECL ³	Ignored	Ignored	Ignored	High	1	1	1
100FX Half-Duplex Operation.	High or PECL ³	Ignored	Ignored	Ignored	Low	0	1	1
Global (Twisted-Pair) Configuration⁵								
Force 100TX Full-Duplex Operation on all ports. ⁴	Low	Low	High	High	Ignored	1	1	0
Force 100TX Half-Duplex Operation on all ports. ⁴	Low	Low	High	Low	Ignored	0	1	0
Force 10T Full-Duplex Operation on all ports.	Low	Low	Low	High	Ignored	1	0	0
Force 10T Half-Duplex Operation on all ports.	Low	Low	Low	Low	Ignored	0	0	0
<ol style="list-style-type: none"> 1. Refer to Table 15 for basic configurations. 2. Refer to Table 16 for Hardware Control Interface functions advertised when auto-negotiation is enabled. 3. When SD/$\overline{TP}n$ is set High or to PECL levels, auto-negotiation is disabled and FDE_FX determines the duplex mode of the port. 4. CFG_2, CFG_0, and SD/$\overline{TP}n$ must all be set for 100TX operation. 5. Fiber configuration must be selected on a per-port basis. 								

2.3 Initialization

At power-up or reset, the LXT974/975 performs the initialization as shown in [Figure 11](#). Control mode selection is provided via the MDDIS pin as shown in [Table 18](#). When MDDIS (pin 100) is High, the LXT974/975 operates in Manual Control Mode. When MDDIS is Low, the LXT974/975 operates in MDIO Control Mode.

2.3.1 MDIO Control Mode

In the MDIO Control Mode, the LXT974/975 uses the Hardware Control Interface to set up initial (default) values of the MDIO registers. The MDIO Register set for the LXT974/975 is described in [Table 44](#) through [Table 55](#). Specific bits in the registers are referenced using an “X.Y” notation, where X is the register number (0-6 or 16-20) and Y is the bit number (0-15). Once initial values are set, bit control reverts to the MDIO interface.

2.3.2 Manual Control Mode

In the Manual Control Mode, LXT974/975 disables direct write operations to the MDIO registers via the MDIO interface. The Hardware Control Interface is continuously monitored and the MDIO registers are updated accordingly.

2.3.3 Link Configuration

When the LXT974/975 is first powered on, reset, or encounters a link failure state, it must determine the line speed and operating conditions to use for the network link.

The LXT974/975 first checks the Hardware Control Interface pins and MDIO registers. Using these mechanisms, the user can command the LXT974/975 to do one of the following:

- Force network link to 100FX (Fiber).
- Force network link operation to:
 - 100TX, Full-Duplex
 - 100TX, Half-Duplex
 - 10BASE-T, Full-Duplex
 - 10BASE-T, Half-Duplex
- Allow auto-negotiation/parallel-detection. The Hardware Control Interface pins are used to set the state of the MDIO advertisement registers.

When forcing the network link, the LXT974/975 immediately begins operating the network interface as commanded. When auto-negotiation is enabled, the auto-negotiation / parallel-detection operation begins.

Table 18. Mode Control Settings

Mode	MDDIS Pin 100	RESET Pin 109	PWR DWN Pin 102
MDIO Control	Low	High	Low
Manual Control	High	High	Low
Reset	-	Low	Low
Power Down	-	-	High

Figure 11. Hardware Interface Mode Selection

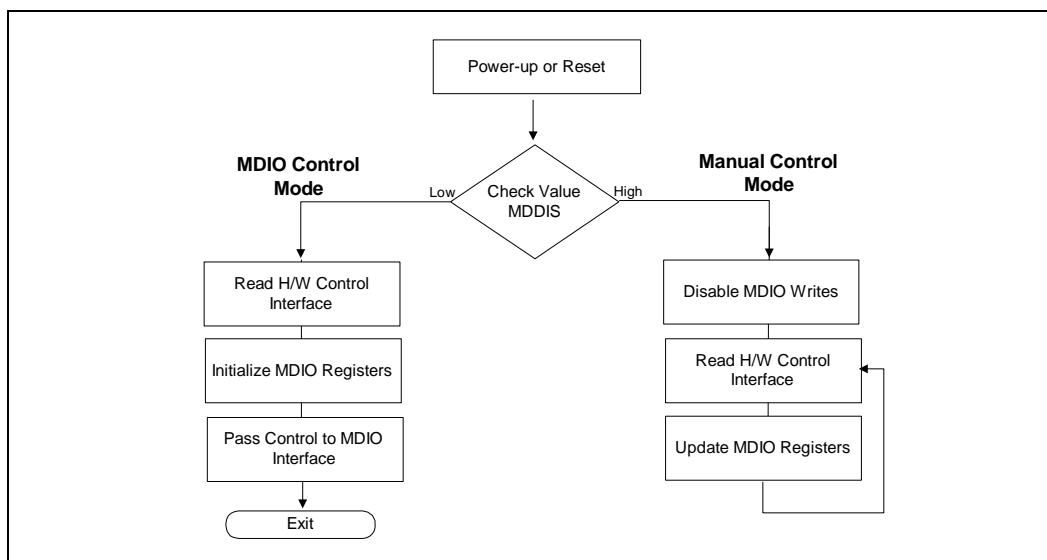

2.4 Auto-Negotiation

The LXT974/975 attempts to auto-negotiate with its counterpart across the link by sending Fast Link Pulse (FLP) bursts. Each burst consists of 33 link pulses spaced 62.5 μ s apart. Odd link pulses (clock pulses) are always present. Even link pulses (data pulses) may be present or absent to indicate a “1” or a “0”. Each FLP burst exchanges 16 bits of data, which are referred to as a “page”. All devices that support auto-negotiation must support a “Base Page” as defined in the IEEE 802.3 standard.

By exchanging Base Pages, the LXT974/975 and its link partner communicate their capabilities to each other. Both sides must receive at least three identical base pages for negotiation to proceed. Each side finds the highest common capabilities that both sides support. Both sides then exchange more pages, and finally agree on the operating state of the line.

2.4.1 Parallel Detection

In parallel with auto-negotiation, the LXT974/975 also monitors for 10 Mbps Normal Link Pulses (NLP) or 100 Mbps Idle symbols. If either is detected, the device automatically reverts to the corresponding operating mode. Parallel detection allows the LXT974/975 to communicate with devices that do not support auto-negotiation.

2.4.2 Controlling Auto-Negotiation

When auto-negotiation is controlled by software, the following steps are recommended:

- After power-up, power-down, or reset, the power-down recovery time, as specified in [Table 41 on page 62](#), must be exhausted before proceeding.
- Set the auto-negotiation advertisement register bits.
- Enable auto-negotiation by setting MDIO bit 0.12 = 1.

2.4.3 Monitoring Auto-Negotiation

When auto-negotiation is being monitored, the following apply:

- Bit 20.13 is set to 1 once the link is established.
- Bits 20.12 and 20.11 can be used to determine the link operating conditions (speed and duplex).

Figure 12. LXT974/975 Auto-Negotiation Operation

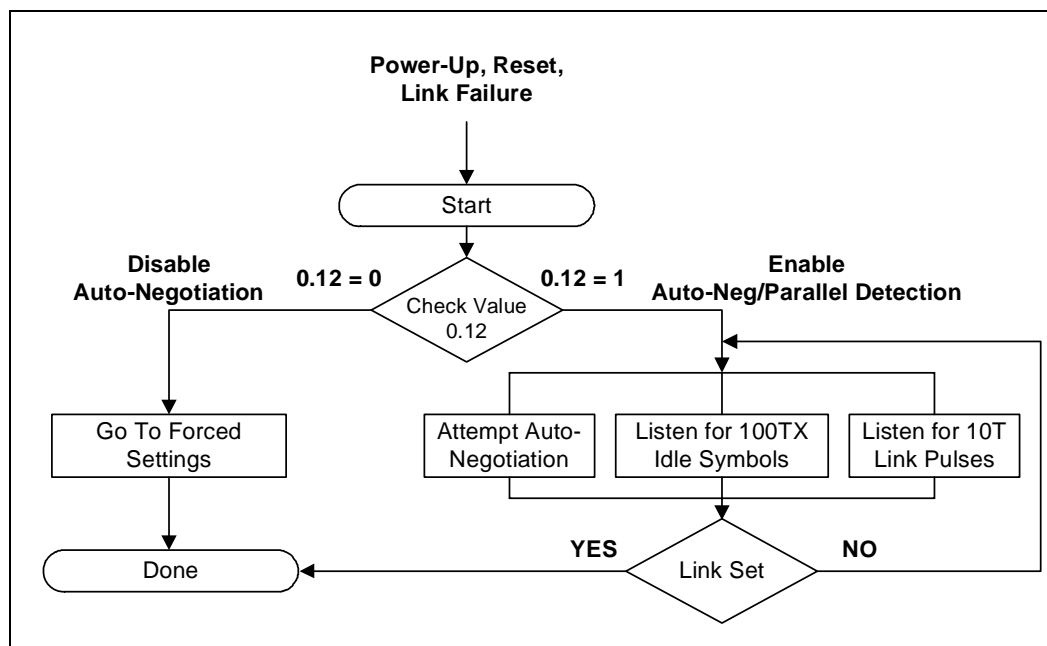

2.5 100 Mbps Operation

2.5.1 100BASE-X MII Operations

The LXT974/975 encodes and scrambles the data sent by the MAC, and then transmits it using MLT3 signaling. The LXT974/975 descrambles and decodes MLT3 data received from the network.

When the MAC is not actively transmitting data, the LXT974/975 sends out Idle symbols.

The 100BASE-X protocol specifies the use of a 5-bit symbol code on the network media. However, data is normally transmitted across the MII interface in 4-bit nibbles. The LXT974/975 incorporates a 4B/5B encoder/decoder circuit that translates 4-bit nibbles from the MII into 5-bit symbols for the 100BASE-X connection, and translates 5-bit symbols from the 100BASE-X connection into 4-bit nibbles for the MII. [Table 12](#) shows the data conversion flow from nibbles to symbols. [Table 19 on page 32](#) shows 4B/5B symbol coding (not all symbols are valid).

2.5.2 100BASE-X Network Operations

During 100BASE-X operation, the LXT974/975 transmits and receives 5-bit symbols across the network link. [Figure 14](#) shows the structure of a standard frame packet. When the MAC is not actively transmitting data, the LXT974/975 sends out Idle symbols on the line.

In 100TX mode, the LXT974/975 scrambles the data and transmits it to the network using MLT-3 line code. The MLT-3 signals received from the network are descrambled and decoded and sent across the MII to the MAC.

In 100FX mode, the LXT974/975 transmits and receives NRZI signals across the PECL interface. An external 100FX transceiver module is required to complete the fiber connection.

As shown in Figure 14, the MAC starts each transmission with a preamble pattern. As soon as the LXT974/975 detects the start of preamble, it transmits a J/K symbol (Start of Stream Delimiter, SSD) to the network. It then encodes and transmits the rest of the packet, including the balance of the preamble, the Start of Frame Delimiter (SFD), packet data, and CRC. Once the packet ends, the LXT974/975 transmits the T/R symbol End-of-Stream Delimiter (ESD) and then returns to transmitting Idle symbols.

Figure 13. 100BASE-TX Data Flow

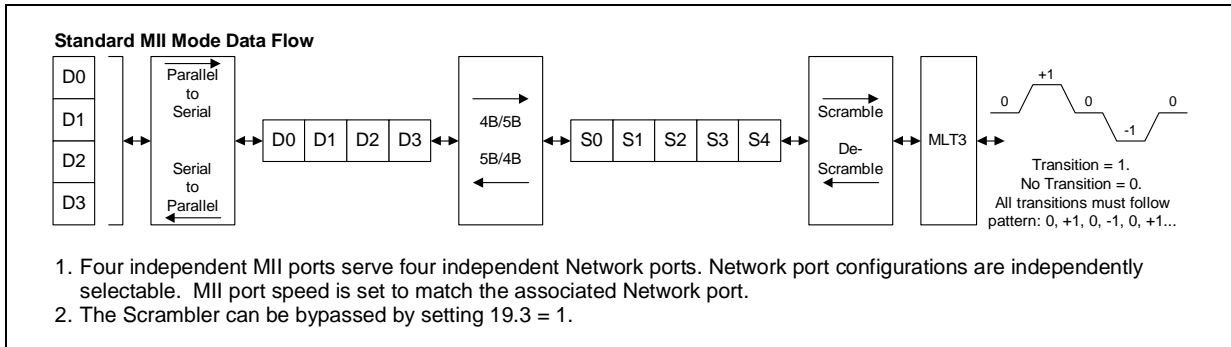

Figure 14. 100BASE-TX Frame Structure

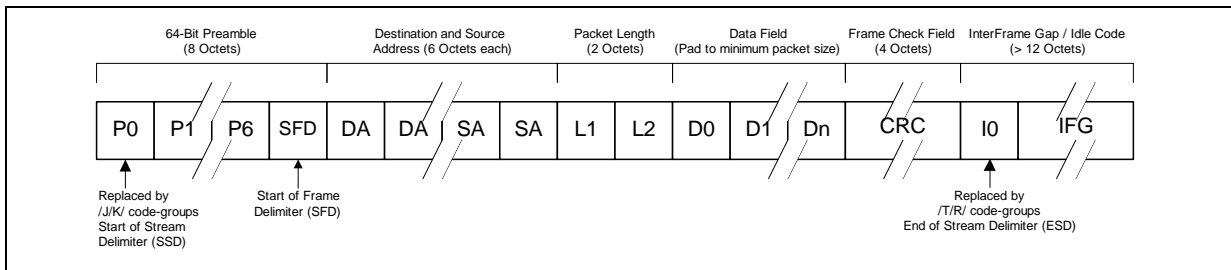

Table 19. 4B/5B Coding

Code Type	4B Code 3 2 1 0	Name	5B Code 4 3 2 1 0	Interpretation
	0 0 0 0	0	1 1 1 1 0	Data 0
	0 0 0 1	1	0 1 0 0 1	Data 1
	0 0 1 0	2	1 0 1 0 0	Data 2
	0 0 1 1	3	1 0 1 0 1	Data 3
	0 1 0 0	4	0 1 0 1 0	Data 4
	0 1 0 1	5	0 1 0 1 1	Data 5
	0 1 1 0	6	0 1 1 1 0	Data 6
DATA	0 1 1 1	7	0 1 1 1 1	Data 7
	1 0 0 0	8	1 0 0 1 0	Data 8
	1 0 0 1	9	1 0 0 1 1	Data 9
	1 0 1 0	A	1 0 1 1 0	Data A
	1 0 1 1	B	1 0 1 1 1	Data B
	1 1 0 0	C	1 1 0 1 0	Data C
	1 1 0 1	D	1 1 0 1 1	Data D
	1 1 1 0	E	1 1 1 0 0	Data E
	1 1 1 1	F	1 1 1 0 1	Data F
IDLE	undefined	I ¹	1 1 1 1 1	Idle. Used as inter-stream fill code
	0 1 0 1	J ²	1 1 0 0 0	Start-of-Stream Delimiter (SSD), part 1 of 2
CONTROL	0 1 0 1	K ²	1 0 0 0 1	Start-of-Stream Delimiter (SSD), part 2 of 2
	undefined	T ³	0 1 1 0 1	End-of-Stream Delimiter (ESD), part 1 of 2
	undefined	R ³	0 0 1 1 1	End-of-Stream Delimiter (ESD), part 2 of 2
	undefined	H ⁴	0 0 1 0 0	Transmit Error. Used to force signaling errors
	undefined	Invalid	0 0 0 0 0	Invalid
	undefined	Invalid	0 0 0 0 1	Invalid
	undefined	Invalid	0 0 0 1 0	Invalid
INVALID	undefined	Invalid	0 0 0 1 1	Invalid
	undefined	Invalid	0 0 1 0 1	Invalid
	undefined	Invalid	0 0 1 1 0	Invalid
	undefined	Invalid	0 1 0 0 0	Invalid
	undefined	Invalid	0 1 1 0 0	Invalid
	undefined	Invalid	1 0 0 0 0	Invalid
	undefined	Invalid	1 1 0 0 1	Invalid

1. The /I/ (Idle) code group is sent continuously between frames.
2. The /J/ and /K/ (SSD) code groups are always sent in pairs; /K/ follows /J/.
3. The /T/ and /R/ (ESD) code groups are always sent in pairs; /R/ follows /T/.
4. An /H/ (Error) code group is used to signal an error condition.

2.5.3 100BASE-X Protocol Sublayer Operations

With respect to the 7-layer communications model, the LXT974/975 is a Physical Layer 1 (PHY) device. The LXT974/975 implements the Physical Coding Sublayer (PCS), Physical Medium Attachment (PMA), and Physical Medium Dependent (PMD) sublayers of the reference model defined by the IEEE 802.3u specification. The following paragraphs discuss LXT974/975 operation from the reference model point of view.

2.5.4 PCS Sublayer

The Physical Coding Sublayer (PCS) provides the MII interface, as well as the 4B/5B encoding/decoding function.

For 100TX and 100FX operation, the PCS layer provides IDLE symbols to the PMD-layer line driver as long as TX_EN is de-asserted.

For 10T operation, the PCS layer merely provides a bus interface and serialization/de-serialization function. 10T operation does not use the 4B/5B encoder.

2.5.4.1 Preamble Handling

When the MAC asserts TX_EN, the PCS substitutes a /J/K symbol pair, also known as the Start of Stream Delimiter (SSD), for the first two nibbles received across the MII. The PCS layer continues to encode the remaining MII data, following [Table 19 on page 32](#), until TX_EN is de-asserted. It then returns to supplying IDLE symbols to the line driver.

In the receive direction, the PCS layer performs the opposite function, substituting two preamble nibbles for the SSD.

Figure 15. LXT974/975 Protocol Sublayers

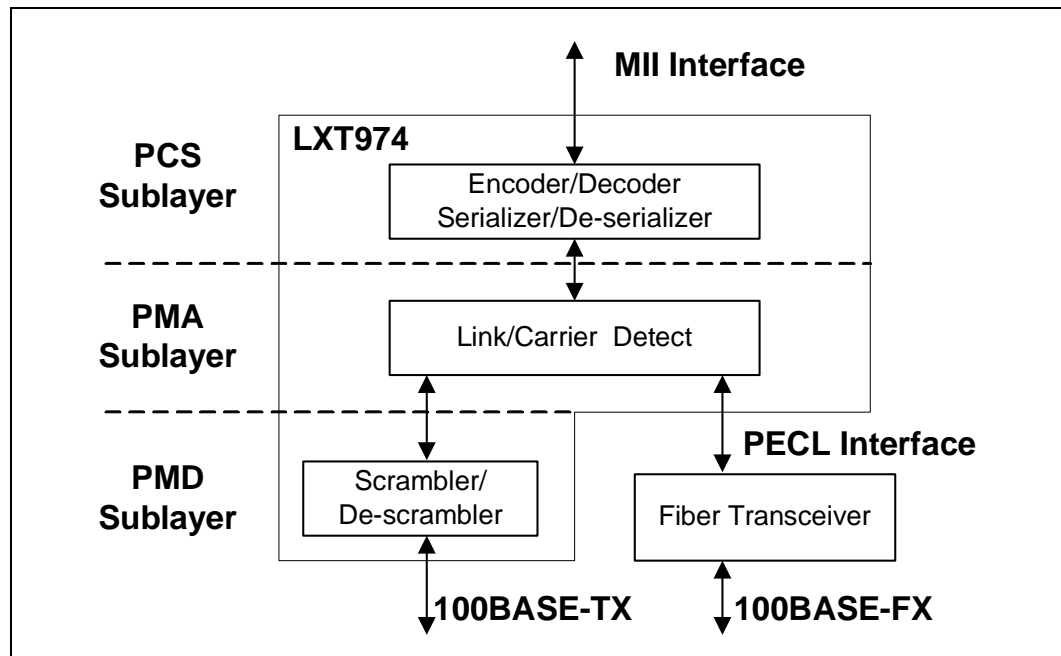

2.5.4.2 Data Errors

Figure 16 shows normal reception. When the LXT974/975 receives invalid symbols from the line, it asserts RX_ER, as shown in Figure 17.

2.5.4.3 Collision Indication

Figure 18 shows normal transmission. The LXT974/975 detects a collision if transmit and receive are active at the same time. As shown in Figure 19, upon detection of a collision, the COL output is asserted and remains asserted for the duration of the collision.

Figure 16. 100BASE-TX Reception with No Errors

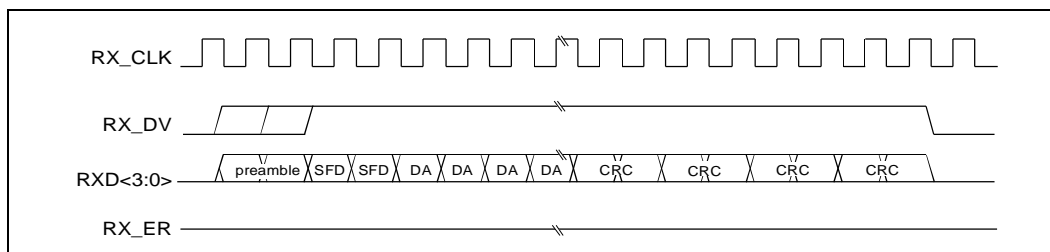

Figure 17. 100BASE-TX Reception with Invalid Symbol

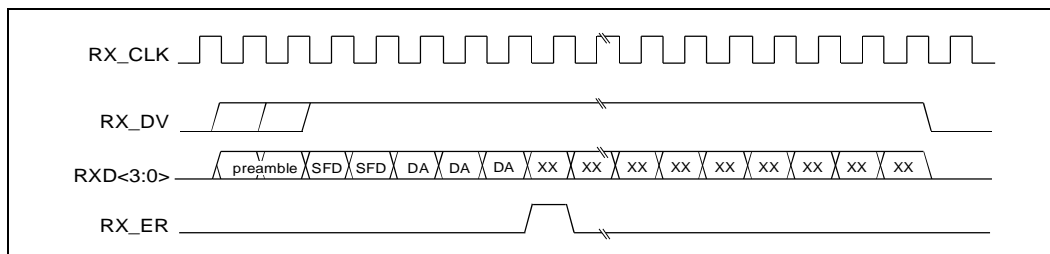

Figure 18. 100BASE-TX Transmission with No Errors

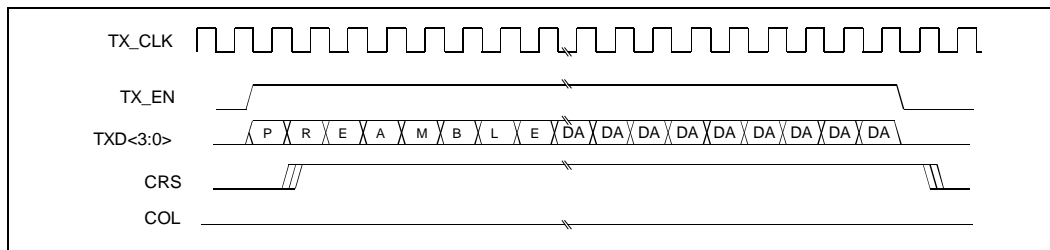
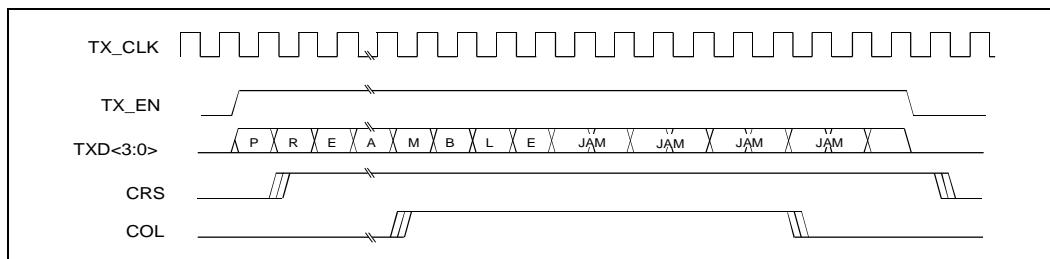

Figure 19. 100BASE-TX Transmission with Collision



2.5.5 PMA Sublayer

2.5.5.1 Link

The LXT974/975 supports a *Standard* link algorithm or *Enhanced* link algorithm, which can be set via bit 16.1. Link is established when the symbol error rate is less than 64 errors out of 1024 symbols received. Once the link is established:

When standard link algorithm is selected (default, bit 16.1 = 0), the link goes down when the symbol error rate becomes greater than 64 out of 1024.

When enhanced link algorithm is selected (bit 16.1 = 1), the link goes down if twelve idle symbols in a row are not received within 1 to 2 ms. This mode makes it more difficult to bring the link down.

In either mode, the LXT974/975 reports link failure via the MII status bits (1.2, 18.15, and 20.13) and interrupt functions. If auto-negotiate is enabled, link failure causes the LXT974/975 to re-negotiate.

2.5.5.2 Link Failure Override

The LXT974/975 normally transmits 100 Mbps data packets or Idle symbols only if it detects the link is up, and transmits only FLP bursts if the link is not up. Setting bit 19.14 = 1 overrides this function, allowing the LXT974/975 to transmit data packets even when the link is down. This feature is provided as a diagnostic tool. Note that auto-negotiation must be disabled to transmit data packets in the absence of link. If auto-negotiation is enabled, the LXT974/975 automatically begins transmitting FLP bursts if the link goes down.

2.5.5.3 Carrier Sense (CRS)

For 100TX and 100FX links, a start of stream delimiter or /J/K symbol pair causes assertion of carrier sense (CRS). An end-of-stream delimiter, or /T/R symbol pair causes de-assertion of CRS. The PMA layer also de-asserts CRS if IDLE symbols are received without /T/R; however, in this case RX_ER is asserted for one clock cycle when CRS is de-asserted.

For 10T links, CRS assertion is based on reception of valid preamble, and de-assertion on reception of an end-of-frame (EOF) marker.

2.5.6 Twisted-Pair PMD Sublayer

The twisted-pair Physical Medium Dependent (PMD) layer provides the signal scrambling and descrambling, line coding and decoding (MLT-3 for 100TX, Manchester for 10T), as well as receiving, polarity correction, and baseline wander correction functions.

2.5.6.1 Scrambler/Descrambler (100TX Only)

The purpose of the scrambler is to spread the signal power spectrum and further reduce EMI using an 11-bit, non-data-dependent polynomial. The receiver automatically decodes the polynomial whenever IDLE symbols are received.

The scrambler/descrambler can be bypassed by either setting bit 19.3 = 1 or setting pin (BYPSCR) High. The scrambler is automatically bypassed when the fiber port is enabled. Scrambler bypass is provided for diagnostic and test support.

2.5.6.2 Baseline Wander Correction

The LXT974/975 provides a baseline wander correction function which makes the device robust under all network operating conditions. The MLT3 coding scheme used in 100BASE-TX is by definition “unbalanced”. This means that the DC average value of the signal voltage can “wander” significantly over short time intervals (tenths of seconds). This wander can cause receiver errors, particularly in less robust designs, at long line lengths (100 meters). The exact characteristics of the wander are completely data dependent.

The LXT974/975 baseline wander correction characteristics allow the LXT974/975 to recover error-free data while receiving worst-case “killer” packets over a variety of cable distances.

2.5.6.3 Polarity Correction

The LXT974/975 automatically detects and corrects for the condition where the receive signal (TPIP/N) is inverted. Reversed polarity is detected if eight inverted link pulses, or four inverted end-of-frame (EOF) markers, are received consecutively. If link pulses or data are not received by the maximum receive time-out period, the polarity state is reset to a non-inverted state.

2.5.7 Fiber PMD Sublayer

The LXT974/975 provides a PECL interface for connection to an external fiber-optic transceiver. (The external transceiver provides the PMD function for fiber media.) The LXT974/975 uses an NRZI format for the fiber interface. The fiber interface operates at 100 Mbps and does not support 10FL applications.

2.6 10 Mbps Operation

The LXT974/975 operates as a standard 10BASE-T transceiver. Data transmitted by the MAC as 4-bit nibbles is serialized, Manchester-encoded, and transmitted on the TPOP/N outputs. Received data is decoded and de-serialized into 4-bit nibbles. The LXT974/975 supports all the standard 10 Mbps functions.

2.6.1 10BASE-T MII Operation

The MAC transmits data to the LXT974/975 via the MII interface. The LXT974/975 converts the digital data from the MAC into an analog waveform that is transmitted to the network via the copper interface. The LXT974/975 converts analog signals received from the network into a digital format suitable for the MAC. The LXT974/975 sends the received data to the MAC via the MII.

2.6.2 10BASE-T Network Operations

During 10BASE-T operation, the LXT974/975 transmits and receives Manchester-encoded data across the network link. When the MAC is not actively transmitting data, the LXT974/975 sends out link pulses on the line.

In 10BASE-T mode, the polynomial scrambler/descrambler is inactive. Manchester-encoded signals received from the network are decoded by the LXT974/975 and sent across the MII to the MAC.

The LXT974/975 does not support fiber connections at 10 Mbps.

2.6.2.1 Preamble Handling

In 10BASE-T Mode, the LXT974/975 strips the entire preamble off of received packets. CRS is asserted a few bit times after carrier is detected. RX_DV is held Low for the duration of the preamble.

When RX_DV is asserted, the very first two nibbles driven by the LXT974/975 are the SFD “5D” hex followed by the body of the packet. In 10T loopback, the LXT974/975 loops back whatever the MAC transmits to it, including the preamble.

2.6.2.2 Link Test

In 10 Mbps mode, the LXT974/975 always transmit link pulses. If the link test function is enabled, it monitors the connection for link pulses. Once link pulses are detected, data transmission are enabled and remain enabled as long as either the link pulses or data transmission continues. If the link pulses stop, the data transmission is disabled.

If the link test function is disabled, the LXT974/975 transmits to the connection regardless of detected link pulses. The link test function can be disabled by setting bit 19.8 = 1 or by setting AUTOENA to disable auto-negotiation and setting CFG_1 input High.

2.6.2.3 Link Failure

Link failure occurs if Link Test is enabled and link pulses or packets stop being received. If this condition occurs, the LXT974/975 returns to the auto-negotiation phase if auto-negotiation is enabled.

2.6.2.4 SQE (Heartbeat)

By default, the SQE (heartbeat) function is disabled on the LXT974/975. To enable this function, set bit 19.10 = 1. When this function is enabled, the LXT974/975 asserts its COL output after each transmit packet. See [Figure 32 on page 58](#) for SQE timing parameters.

2.6.2.5 Jabber

If MAC transmission exceeds the jabber timer, the LXT974/975 disables the transmit and loopback functions and enables the COL pin. See [Figure 33 on page 59](#) for jabber timing parameters.

The LXT974/975 automatically exits jabber mode after the unjab time has expired. This function can be disabled by setting bit 19.9 = 1.

2.7 LED Functions

The LXT974/975 provides three programmable LEDs per port. Refer to [Table 51 on page 68](#) for LED programming details. The LXT974/975 also provides a serial LED output.

2.7.1 Serial LED Output

The LXT974/975 provides a serial LED interface which should be attached to an external shift register. This interface provides 24 status bits (6 x 4 ports). Each port reports the following conditions:

- Transmit (T)
0 = Transmit active 1 = Transmit inactive
- Receive (R)
0 = Receive active 1 = Receive inactive
- Link (L)
0 = Link active 1 = Link inactive
- Duplex (D)
0 = Half-Duplex 1 = Full-Duplex
- Speed (S)
0 = 100 Mbps 1 = 10 Mbps
- Collision (C)
0 = Collision active 1 = Collision inactive

LED Data is output on LEDDAT in sets of 24 bits. The serial burst is repeated every 1 ms. A status change in any bit also triggers an immediate serial burst (following the minimum inter-burst gap of 10 μ s). LEDENA is driven High for the duration of the LEDDAT output.

2.7.2 Per Port LEDs

The LXT974/975 provides three LED outputs for each port (LED n _0, LED n _1 and LED n _2, where n = port number). These outputs can directly drive LEDs to indicate activity and collision status. The active Low “on” times are normally extended for improved LED visibility. The on-time extension can be disabled by setting bit 16.0 = 1.

2.7.2.1 LED n _0

In default mode, LED_0 indicates transmitter active. However, LED n _0 is programmable and may also be set to indicate receiver active, link, or full-duplex status. Refer to LED Configuration Register, [Table 51 on page 68](#), for details on programming options.

2.7.2.2 LED n _1

In default mode, LED_1 indicates receiver active. However, LED n _1 is programmable and may also be set to indicate link status, full-duplex status or operating speed. Refer to LED Configuration Register, [Table 51 on page 68](#), for details on programming options.

2.7.2.3 LED n _2

In default mode, active Low output indicates link up. However, LED n _2 is programmable and may also be set to indicate full-duplex status, operating speed or collision. Refer to LED Configuration Register, [Table 51 on page 68](#), for details on programming options.

Table 20. LED-DAT Serial Port Bit Assignments

Port 0						Port 1						Port 2		Port 3					
23 ¹	22	21	20	19	18	17	16	15	14	13	12	11 : 6		5	4	3	2	1	0
T	R	L	D	S	C	T	R	L	D	S	C	TRLDSC		T	R	L	D	S	C

1. Bit 23 is shifted out first.

2.8 Operating Requirements

2.8.1 Power Requirements

The LXT974/975 requires four +5V supply inputs (VCC, VCCR, VCCT, and VCCH). These inputs may be supplied from a single source although decoupling is required to each respective ground. As a matter of good practice, these supplies should be as clean as possible. Typical filtering and decoupling are shown in [Figure 22 on page 46](#).

2.8.1.1 MII Power Requirements

An additional supply may be used for the MII (VCCMII). The supply may be either +5V or +3.3V. When the MII supply is 3.3V, MII inputs may not be driven with 5V levels. VCCMII should be supplied from the same power source used to supply the controller on the other side of the MII interface. Refer to [Table 25 on page 51](#) for MII I/O characteristics.

2.8.1.2 Low-Voltage Fault Detect

The LXT974/975 has a low-voltage fault detection function that prevents transmission of invalid symbols when VCC goes below normal operating levels. This function disables the transmit outputs when a low-voltage fault on VCC occurs. If this condition happens, bit 20.2 is set High. Operation is automatically restored when VCC returns to normal. [Table 27 on page 51](#) indicates voltage levels used to detect and clear the low-voltage fault condition.

2.8.1.3 Power Down Mode

The LXT974/975 goes into Power Down Mode when PWRDWN is asserted. In this mode, all functions are disabled except the MDIO. The power supply current is significantly reduced. This mode can be used for energy-efficient applications or for redundant applications where there are two devices and one is left as a standby. When the LXT974/975 is returned to normal operation, configuration settings of the MDIO registers are maintained. Refer to [Table 23 on page 50](#) for power down specifications.

2.8.2 Clock Requirements

The LXT974/975 requires a constant 25 MHz clock (CLK25M) that must be enabled at all times. Refer to Test Specifications, [Table 26 on page 51](#), for clock timing requirements.

3.0 Application Information

3.1 Design Recommendations

The LXT974/975 is designed to comply with IEEE requirements and to provide outstanding receive Bit Error Rate (BER) and long-line-length performance. Lab testing has shown that the LXT974/975 can perform well beyond the required distance of 100 meters. To achieve maximum performance from the LXT974/975, attention to detail and good design practices are required. Refer to the LXT974/975 Design and Layout Guide for detailed design and layout information.

3.1.1 General Design Guidelines

Adherence to generally accepted design practices is essential to minimize noise levels on power and ground planes. Up to 50 mV of noise is considered acceptable. 50 to 80 mV of noise is considered marginal. High-frequency switching noise can be reduced, and its effects can be eliminated, by following these simple guidelines throughout the design:

- Fill in unused areas of the signal planes with solid copper and attach them with vias to a VCC or ground plane that is not located adjacent to the signal layer.
- Use ample bulk and decoupling capacitors throughout the design (a value of .01 μ F is recommended for decoupling caps).
- Provide ample power and ground planes.
- Provide termination on all high-speed switching signals and clock lines.
- Provide impedance matching on long traces to prevent reflections.
- Route high-speed signals next to a continuous, unbroken ground plane.
- Filter and shield DC-DC converters, oscillators, etc.
- Do not route any digital signals between the LXT974/975 and the RJ-45 connectors at the edge of the board.
- Do not extend any circuit power and ground plane past the center of the magnetics or to the edge of the board. Use this area for chassis ground, or leave it void.

3.1.2 Power Supply Filtering

Power supply ripple and digital switching noise on the VCC plane can cause EMI problems and degrade line performance. It is generally difficult to predict in advance the performance of any design, although certain factors greatly increase the risk of having these problems:

- Poorly-regulated or over-burdened power supplies.
- Wide data busses (>32-bits) running at a high clock rate.
- DC-to-DC converters.

Many of these issues can be improved just by following good general design guidelines. In addition, Intel also recommends filtering between the power supply and the analog VCC pins of the LXT974/975. Filtering has two benefits. First, it keeps digital switching noise out of the analog

circuitry inside the LXT974/975, which helps line performance. Second, if the VCC planes are laid out correctly, it keeps digital switching noise away from external connectors, reducing EMI problems.

The recommended implementation is to divide the VCC plane into two sections. The digital section supplies power to the digital VCC pin, MII VCC pin, and to the external components. The analog section supplies power to VCCH, VCCT, and VCCR pins of the LXT974/975. The break between the two planes should run under the device. In designs with more than one LXT974/975, a single continuous analog VCC plane can be used to supply them all.

The digital and analog VCC planes should be joined at one or more points by ferrite beads. The beads should produce at least a 100Ω impedance at 100 MHz. The beads should be placed so that current flow is evenly distributed. The maximum current rating of the beads should be at least 150% of the current that is actually expected to flow through them. Each LXT974/975 draws a maximum of 500 mA from the analog supply so beads rated at 750 mA should be used. A bulk cap (2.2 - 10 μF) should be placed on each side of each ferrite bead to stop switching noise from traveling through the ferrite.

In addition, a high-frequency bypass cap (.01μf) should be placed near each analog VCC pin.

3.1.2.1 Ground Noise

The best approach to minimize ground noise is strict use of good general design guidelines and by filtering the VCC plane.

3.1.3 Power and Ground Plane Layout Considerations

Great care needs to be taken when laying out the power and ground planes. The following guidelines are recommended:

- Follow the guidelines in the *LXT974/975 Layout Guide* for locating the split between the digital and analog VCC planes.
- Keep the digital VCC plane away from the TPOP/N and TPIP/N signals, away from the magnetics, and away from the RJ-45 connectors.
- Place the layers so that the TPOP/N and TPIP/N signals can be routed near or next to the ground plane. For EMI reasons, it is more important to shield TPOP/N and TPIP/N.

3.1.3.1 Chassis Ground

For ESD reasons, it is a good design practice to create a separate chassis ground that encircles the board and is isolated via moats and keep-out areas from all circuit-ground planes and active signals. Chassis ground should extend from the RJ-45 connectors to the magnetics, and can be used to terminate unused signal pairs ('Bob Smith' termination). In single-point grounding applications, provide a single connection between chassis and circuit grounds with a 2kV isolation capacitor. In multi-point grounding schemes (chassis and circuit grounds joined at multiple points), provide 2kV isolation to the Bob Smith termination.

3.1.4 MII Terminations

Series termination resistors are not required on the MII signals driven by the LXT974/975.

3.1.5 The RBIAS Pin

The LXT974/975 requires a 22 k Ω , 1% resistor directly connected between the RBIAS pin and ground. Place the RBIAS resistor as close to the RBIAS pin as possible. Run an etch directly from the pin to the resistor, and sink the other side of the resistor to a filtered ground. Surround the RBIAS trace with a filtered ground; do not run high-speed signals next to RBIAS.

3.1.6 The Twisted-Pair Interface

Because the LXT974/975 transmitter uses 2:1 magnetics, system designers must take extra precautions to minimize parasitic shunt capacitance in order to meet return loss specifications. These steps include:

- Use compensating inductor in the output stage (see [Figure 23 on page 47](#)).
- Place the magnetics as close as possible to the LXT974/975.
- Keep transmit pair traces short.
- Route the transmit pair adjacent to a ground plane. The optimum arrangement is to place the transmit traces two to three layers from the ground plane, with no intervening signals.
- Some magnetic vendors are producing magnetics with improved return loss performance. Use of these improved magnetics increases the return loss budget available to the system designer.
- Improve EMI performance by filtering the output center tap. A single ferrite bead may be used to supply center tap current to all 4 ports. All four ports draw a combined total of ≥ 270 mA so the bead should be rated at ≥ 400 mA.

In addition, follow all the standard guidelines for a twisted-pair interface:

- Route the signal pairs differentially, close together. Allow nothing to come between them.
- Keep distances as short as possible; both traces should have the same length.
- Avoid vias and layer changes as much as possible.
- Keep the transmit and receive pairs apart to avoid cross-talk.
- Put all the components for the transmit network on the front side of the board (same side as the LXT974/975).
- Put entire receive termination network on the back side of the board.
- Bypass common-mode noise to ground on the in-board side of the magnetics using 0.01 μ F capacitors.
- Keep termination circuits close together and on the same side of the board.
- Always put termination circuits close to the source end of any circuit.

3.1.7 The Fiber Interface

The fiber interface consists of a PECL transmit and receive pair to an external fiber-optic transceiver. The transmit pair should be AC-coupled to the transceiver, and biased to 3.7V with a 50 Ω equivalent impedance. The receive pair can be DC-coupled, and should be biased to 3.0V with a 50 Ω equivalent impedance. [Figure 24 on page 48](#) shows the correct bias networks to achieve these requirements.

3.2 Magnetics Information

The LXT974/975 requires a 1:1 ratio for the receive transformers and a 2:1 ratio for the transmit transformers as shown in Table 21. The transformer isolation voltage should be rated at 2 kV to protect the circuitry from static voltages across the connectors and cables.

Refer to the *Magnetic Manufacturers Cross Reference Guide* (Application Note 73) for a list of suitable magnetic manufacturers and part numbers. The latest version is located on the Intel web site (<http://developer.intel.com/design/network/>). Suitable Magnetic part numbers are provided as a reference only. Before committing to a specific component, designers should contact the manufacturer for current product specifications, and validate the magnetics for a specific application.

3.2.1 Magnetics With Improved Return Loss Performance

Intel is working with magnetic vendors to develop magnetic modules with improved return loss characteristics. These improved magnetics simplify the design requirements for meeting ANSI X3.263 return loss specifications.

Table 21. Magnetics Requirements

Parameter	Min	Nom	Max	Units	Test Condition
Rx turns ratio	–	1 : 1	–	–	
Tx turns ratio	–	2 : 1	–	–	
Insertion loss	0.0	–	1.1	dB	80 MHz
Primary inductance	350	–	–	μH	
Transformer isolation	–	2	–	kV	
Differential to common mode rejection	40	–	–	dB	.1 to 60 MHz
	35	–	–	dB	60 to 100 MHz
Return Loss - Standard	–	–	-16	dB	30 MHz
	–	–	-10	dB	80 MHz
Return Loss - Improved	–	–	-20	dB	30 MHz
	–	–	-15	dB	80 MHz

3.3 Twisted-Pair/ RJ-45 Interface

Figure 20 shows layout of the LXT974 twisted-pair interface in a single-high RJ-45 modular application. Figure 21 shows layout of the LXT975 twisted-pair interface in a dual-high (stacked) RJ-45 application.

Figure 20. Typical LXT974 Twisted-Pair Single RJ-45 Modular Application

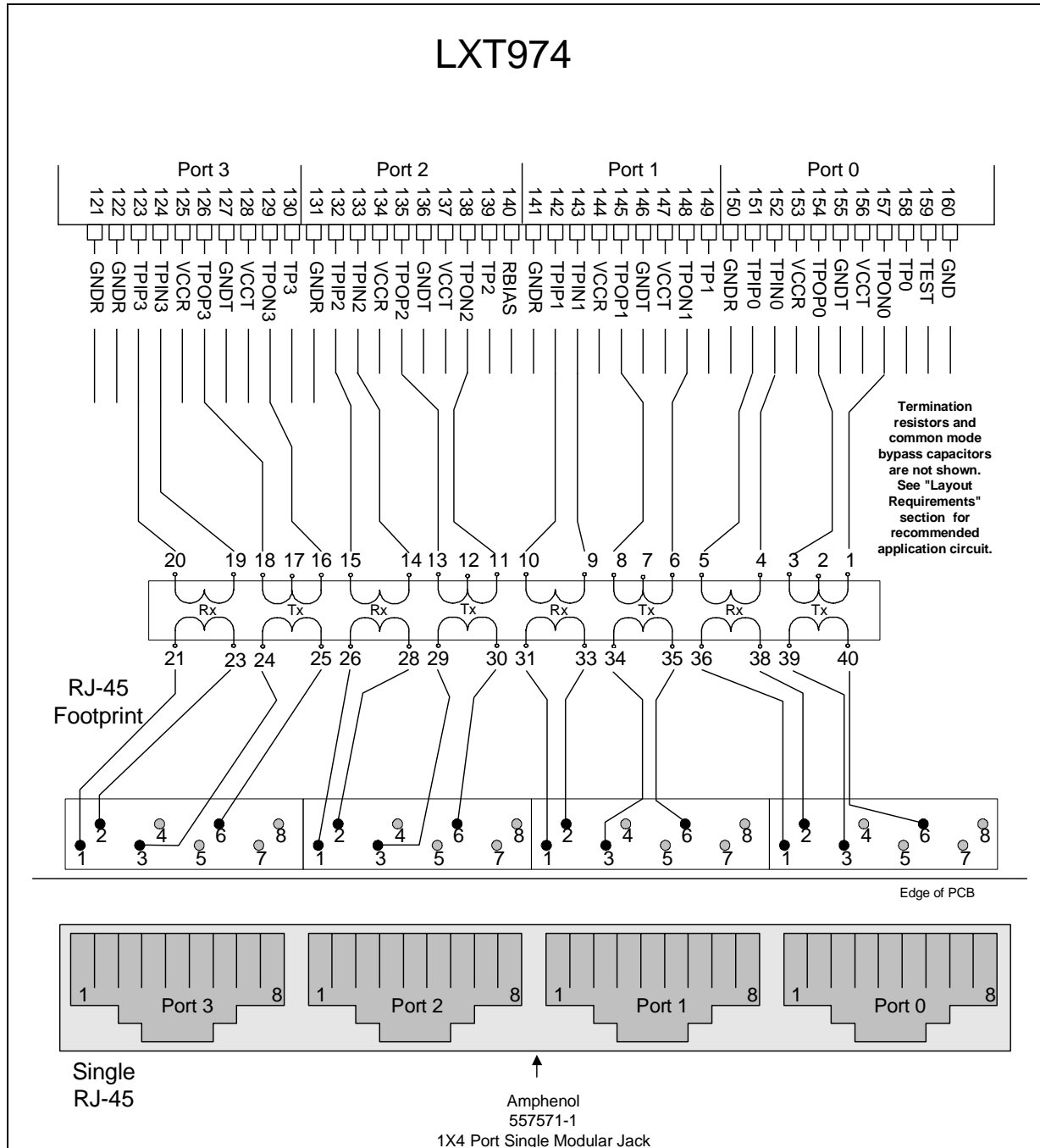

Figure 21. Typical LXT975 Twisted-Pair Stacked RJ-45 Modular Application

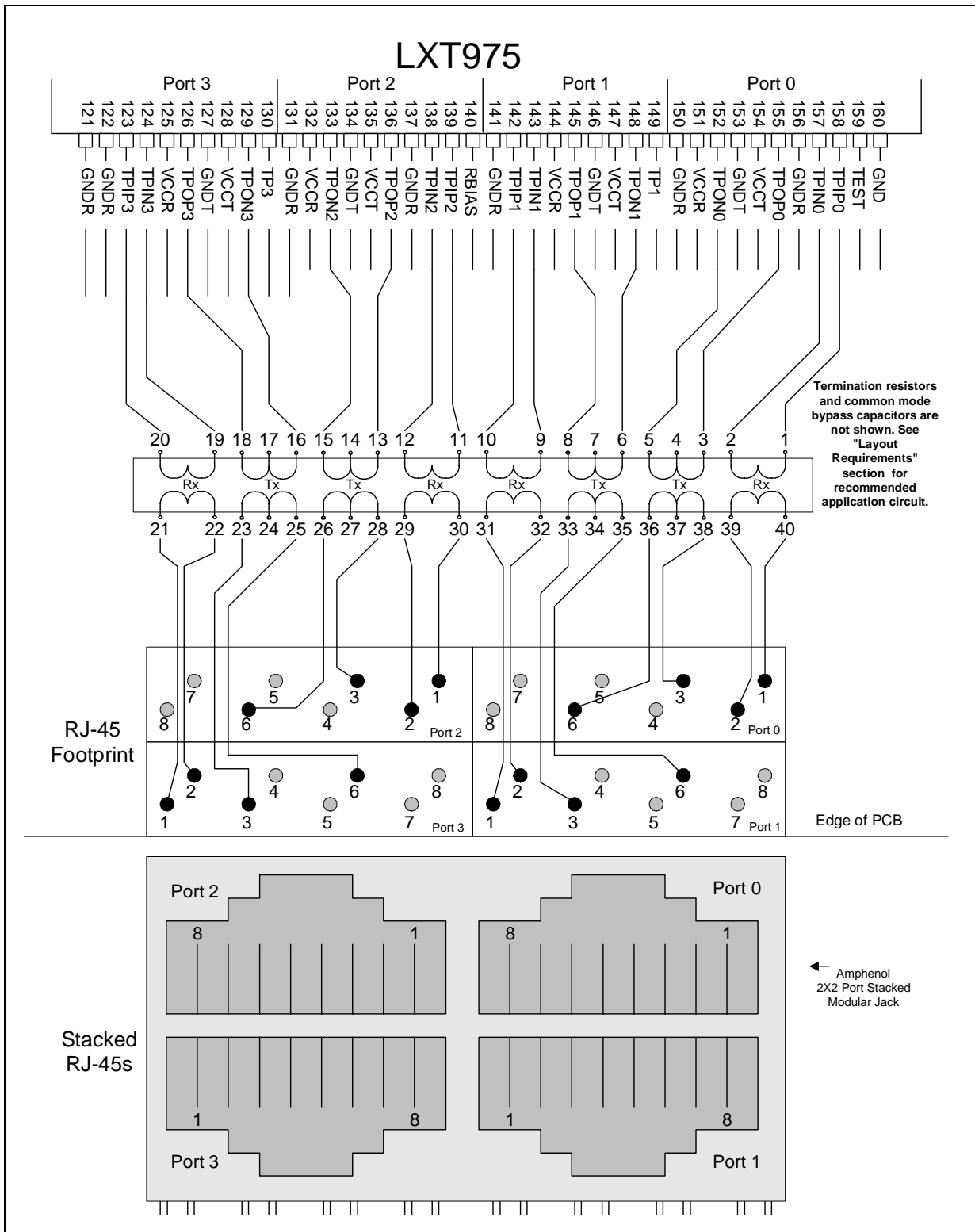

Figure 22. LXT974/975 Power and Ground Connections

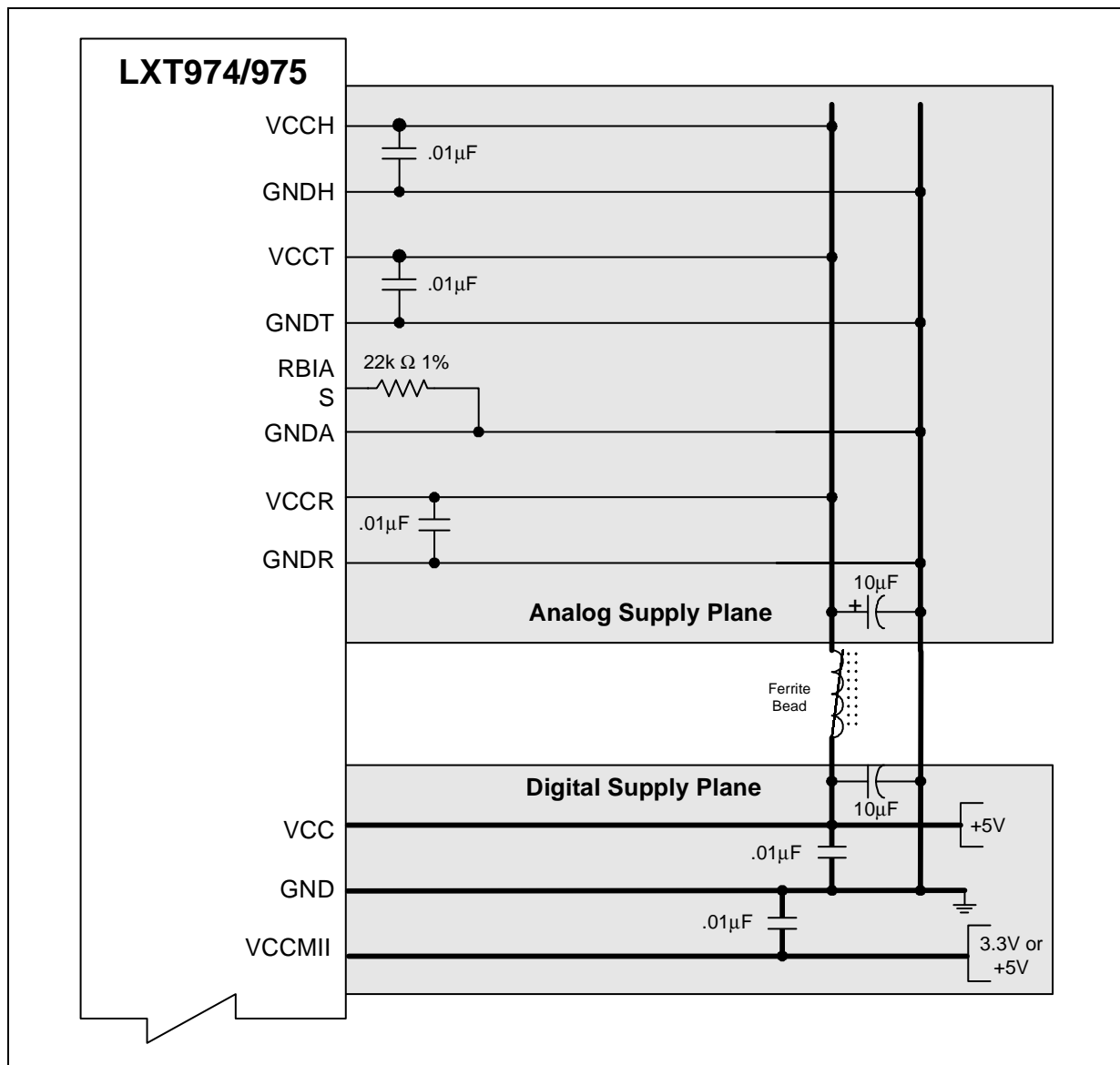

Figure 23. Typical Twisted-Pair Interface and Supply Filtering

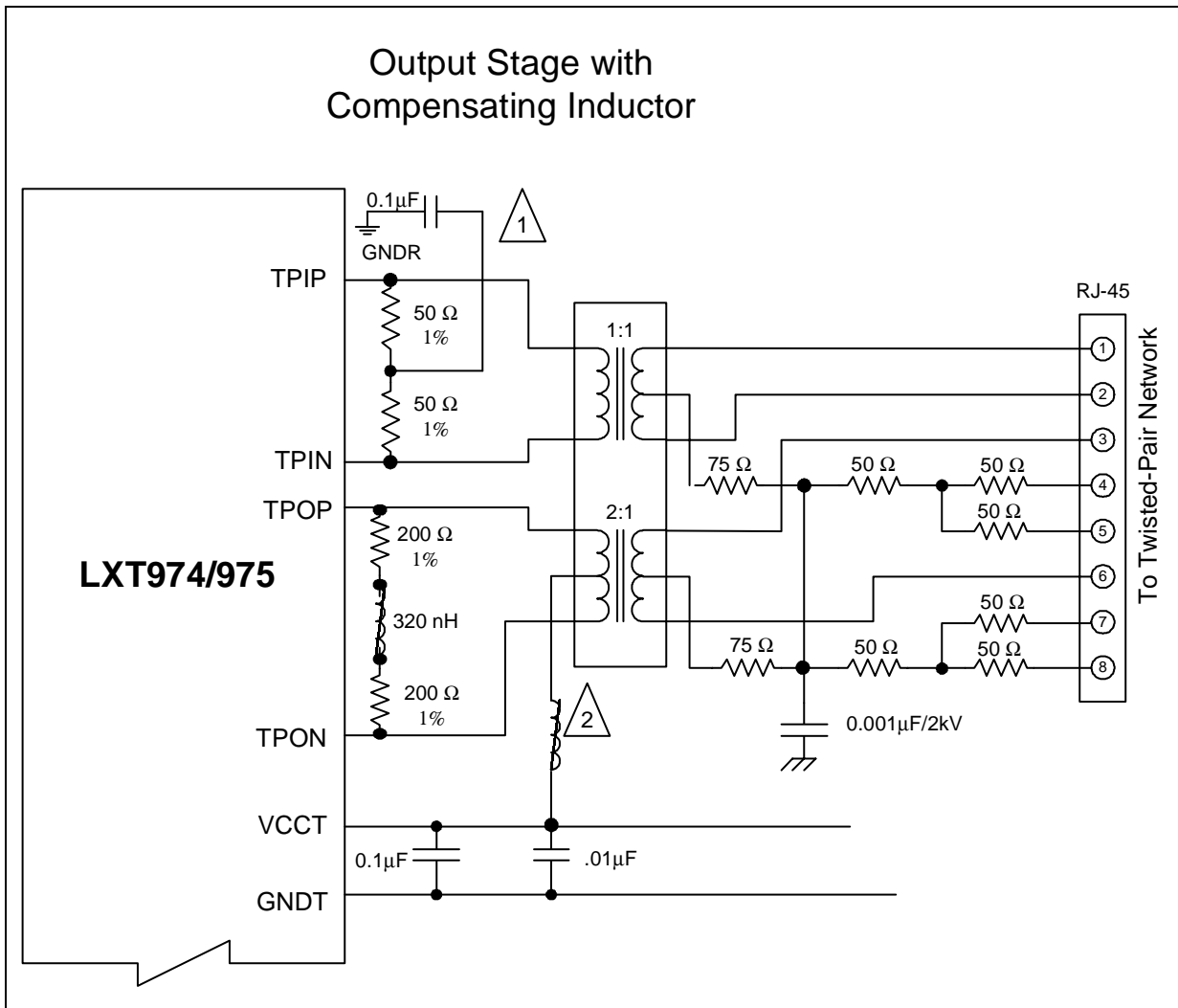

Figure 24. Typical Fiber Interface

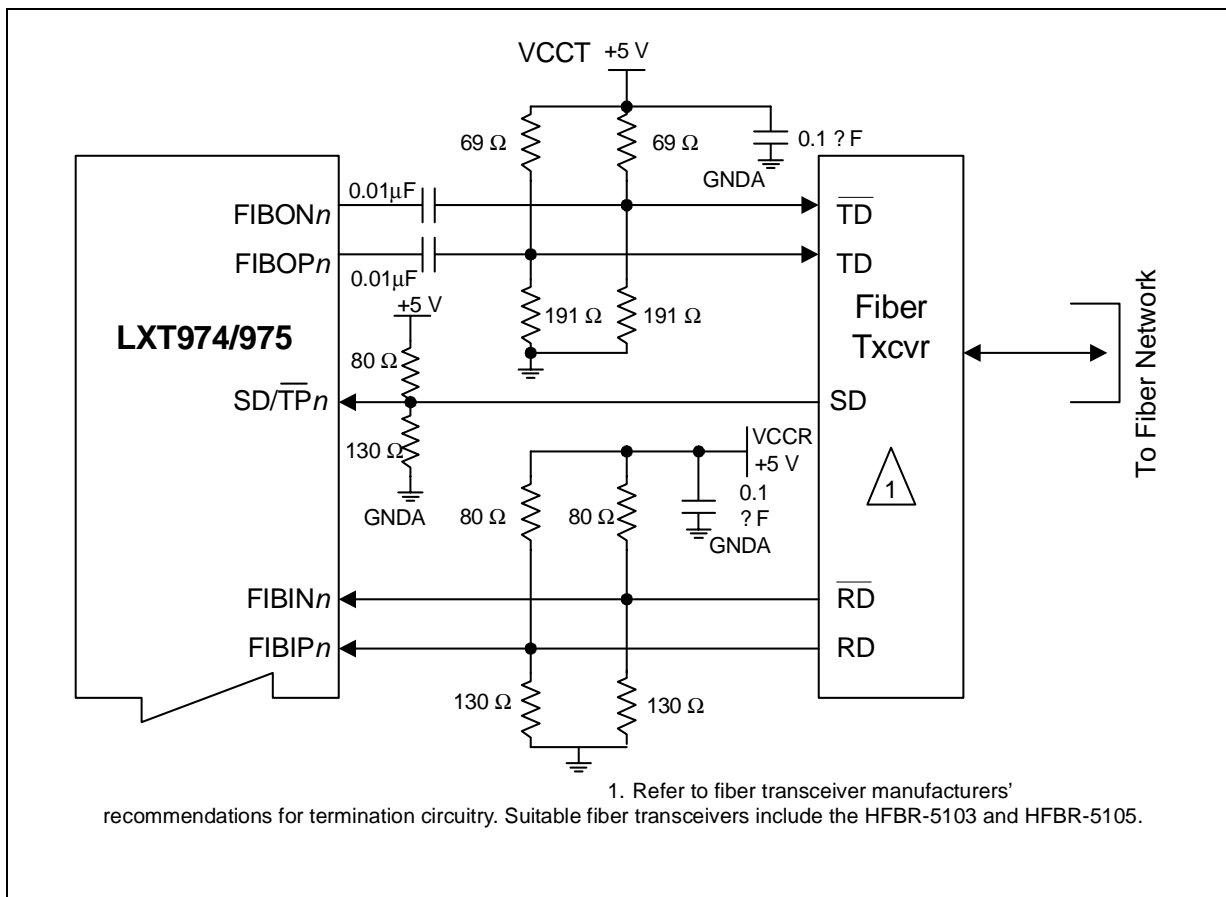
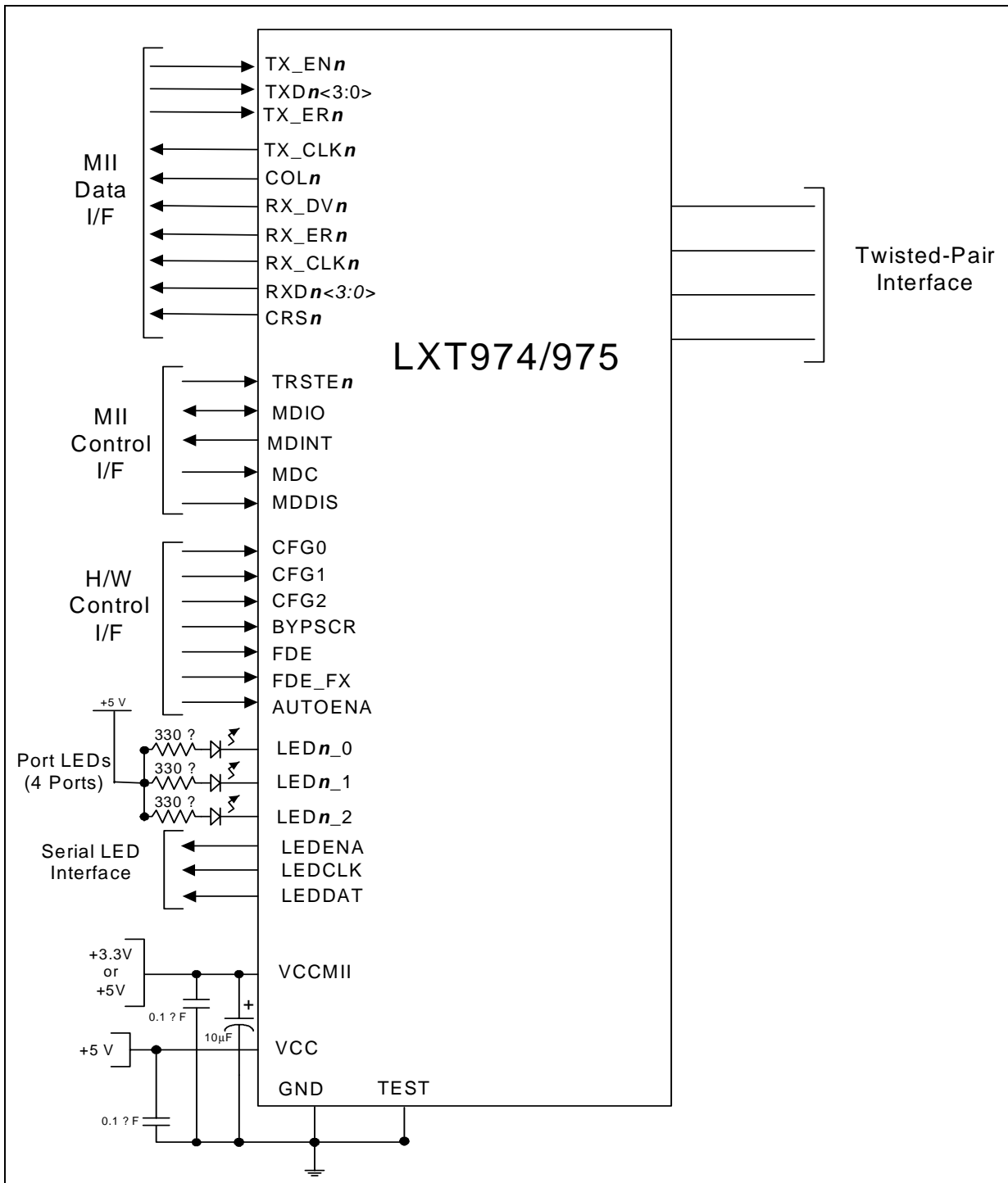

Figure 25. Typical MII Interface



4.0 Test Specifications

Note: The minimum and maximum values in Table 22 through Table 42 and Figure 26 through Figure 39 represent the performance specifications of the LXT974/975 and are guaranteed by test, except where noted by design. Minimum and maximum values in Table 24 through Table 42 apply over the recommended operating conditions specific in Table 23.

Table 22. Absolute Maximum Ratings

Parameter		Sym	Min	Max	Units
Supply voltage		V _{CC}	-0.3	6	V
Operating temperature	Ambient	TOPA	-15	+85	°C
	Case	TOPC	–	+120	°C
Storage temperature		T _{ST}	-65	+150	°C
Caution: Exceeding these values may cause permanent damage. Functional operation under these conditions is not implied. Exposure to maximum rating conditions for extended periods may affect device reliability.					

Table 23. Operating Conditions

Parameter		Sym	Min	Typ ¹	Max	Units
Recommended supply voltage ²	Except MII Supply	V _{CC}	4.75	5.0	5.25	V
	II Supply	V _{CC} MII	3.125	–	5.25	V
Recommended operating temperature	Ambient	TOPA	0	–	70	°C
	Case	TOPC	0	–	110	°C
V _{CC} current	100BASE-TX	I _{CC}	–	–	570	mA
	100BASE-FX	I _{CC}	–	–	500	mA
	10BASE-T	I _{CC}	–	–	570	mA
	Power Down Mode	I _{CC}	–	0.5	3.0	mA
	Auto-Negotiation	I _{CC}	–	–	570	mA
1. Typical values are at 25 °C and are for design aid only; not guaranteed and not subject to production testing. 2. Voltages with respect to ground unless otherwise specified.						

Table 24. Digital I/O Characteristics¹

Parameter	Symbol	Min	Typ ²	Max	Units	Test Conditions
Input Low voltage ³	V _{IL}	–	–	0.8	V	–
Input High voltage ³	V _{IH}	2.0	–	–	V	–
Input current	I _I	-100	–	100	μA	0.0 < V _I < V _{CC}
Output Low voltage	V _{OL}	–	–	0.4	V	I _{OL} = 4 mA
Output High voltage	V _{OH}	2.4	–	–	V	I _{OH} = -4 mA
1. Applies to all pins except MII pins. Refer to Table 25 for MII I/O Characteristics. 2. Typical values are at 25 °C and are for design aid only; not guaranteed and not subject to production testing. 3. Does not apply to CLK25M. Refer to Table 26 for clock input levels.						

Table 25. Digital I/O Characteristics - MII Pins)

Parameter	Symbol	Min	Typ	Max	Units	Test Conditions
Input Low voltage	V _{IL}	–	–	.8	V	–
Input High voltage	V _{IH}	2.0	–	–	V	–
Input current	I _I	-100	–	100	μA	0.0 < V _I < V _{CC}
Output Low voltage	V _{OL}	–	–	0.4	V	I _{OL} = 4 mA
Output High voltage	V _{OH}	2.2	–	–	V	I _{OH} = -4 mA, V _{CC} = 3.3V
	V _{OH}	2.4	–	–	V	I _{OH} = -4 mA, V _{CC} = 5.0V
Driver output resistance (Line driver output enabled)	R _O ¹	50	100	200	Ω	V _{CC} = 3.3V
	R _O ¹	50	100	200	Ω	V _{CC} = 5.0V

1. Parameter is guaranteed by design; not subject to production testing.

Table 26. Required CLK25M Characteristics

Parameter	Sym	Min	Typ	Max	Units	Test Conditions
Input Low voltage	V _{IL}	–	–	.8	V	–
Input High voltage	V _{IH}	2.0	–	–	V	–
Input clock frequency tolerance ¹	Δf	–	–	± 100	ppm	Clock frequency is 25 MHz
Input clock duty cycle ¹	T _{dc}	40	–	60	%	–

1. Parameter is guaranteed by design; not subject to production testing.

Table 27. Low-Voltage Fault Detect Characteristics

Parameter	Sym	Min	Typ ¹	Max	Units	Test Conditions
Detect fault threshold	V _{LT}	3.4	–	4.0	V	–
Clear fault threshold	V _{LH}	4.1	–	4.7	V	–

1. Typical values are at 25 °C and are for design aid only; not guaranteed and not subject to production testing.

Table 28. 100BASE-TX Transceiver Characteristics

Parameter	Sym	Min	Typ ¹	Max	Units	Test Conditions
Peak differential output voltage	V _P	0.95	–	1.05	V	Note 2
Signal amplitude symmetry	V _{SS}	98	–	102	%	Note 2
Signal rise/fall time	T _{RF}	3.0	–	5.0	ns	Note 2
Rise/fall time symmetry	T _{RFS}	–	–	0.5	ns	Note 2
Jitter (measured differentially)	–	–	0.7	1.4	ns	–
Duty cycle distortion	–	–	–	+/- 0.5	ns	Offset from 16ns pulse width at 50% of pulse peak
Overshoot	V _O	–	–	5	%	–

1. Typical values are at 25 °C and are for design aid only; not guaranteed and not subject to production testing.
2. Measured at the line side of the transformer, line replaced by 100Ω(+/-1%) resistor.

Table 29. 100BASE-FX Transceiver Characteristics

Parameter	Sym	Min	Typ ¹	Max	Units	Test Conditions
Transmitter						
Peak differential output voltage (single ended)	VOP	0.6	–	1.5	V	–
Signal rise/fall time	TRF	–	–	1.6	ns	10 <-> 90% 2.0 pF load
Jitter (measured differentially)	–	–	–	1.3	ns	–
Receiver						
Peak differential input voltage	VIP	0.55	–	1.5	V	–
Common mode input range	VCMIR	2.25	–	VCC - 0.5	V	–
1. Typical values are at 25 °C and are for design aid only; not guaranteed and not subject to production testing.						

Table 30. 10BASE-T Transceiver Characteristics

Parameter	Sym	Min	Typ ¹	Max	Units	Test Conditions
Transmitter						
Peak differential output voltage	VOP	2.2	2.5	2.8	V	With specified transformer, line replaced by 100Ω (±1%) resistor
Link transmit period	–	8	–	24	ms	–
Transmit timing jitter added by the MAU and PLS sections ^{2,3}	–	0	2	11	ns	After line model specified by IEEE 802.3 for 10BASE-T MAU
Receiver						
Receive input impedance ²	ZIN	–	3.6	–	kΩ	Between TPIP and TPIN
Link min receive	–	2	–	7	ms	–
Link max receive	–	50	–	150	ms	–
Time link loss receive	–	50	–	150	ms	–
Differential squelch threshold	VDS	300	390	585	mV Peak	5 MHz square wave input
1. Typical values are at 25 °C and are for design aid only; not guaranteed and not subject to production testing.						
2. Parameter is guaranteed by design; not subject to production testing.						
3. IEEE 802.3 specifies maximum jitter addition at 1.5 ns for the AU1 cable, 0.5 ns from the encoder, and 3.5 ns from the MAU.						

Figure 26. MII - 100BASE-TX Receive Timing

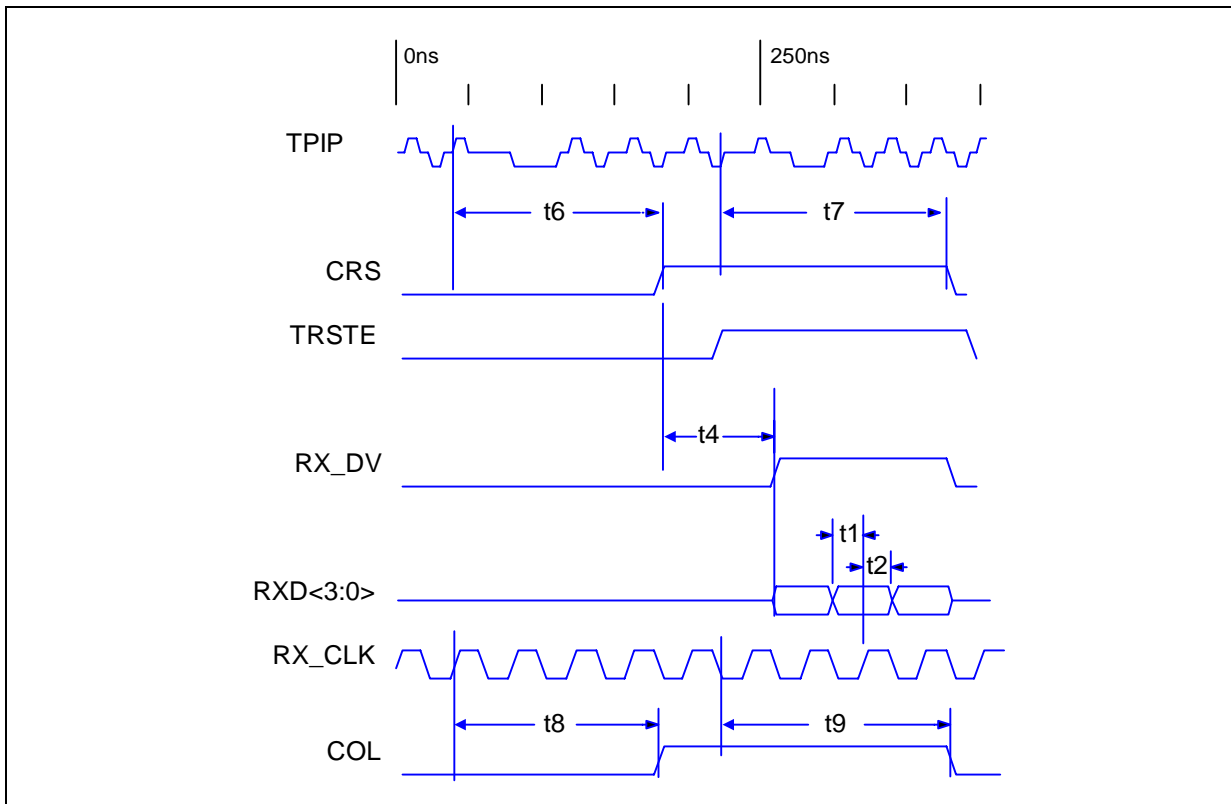

Table 31. MII - 100BASE-TX Receive Timing Parameters

Parameter	Sym	Min	Typ ¹	Max	Units
RXD, RX_DV, RX_ER setup to RX_CLK High	t1	10	–	–	ns
RXD, RX_DV, RX_ER hold from RX_CLK High	t2	5	–	–	ns
CRS asserted to RXD<3:0>, RX_DV	t4	–	8	–	BT
Receive start of “J” to CRS asserted	t6	0	15 - 19	20	BT
Receive start of “T” to CRS de-asserted	t7	13	23 - 27	28	BT
Receive start of “J” to COL asserted	t8	0	15 - 19	20	BT
Receive start of “T” to COL de-asserted	t9	13	23 - 27	28	BT

1. Typical values are at 25 °C and are for design aid only; not guaranteed and not subject to production testing.

Figure 27. MII - 100BASE-TX Transmit Timing

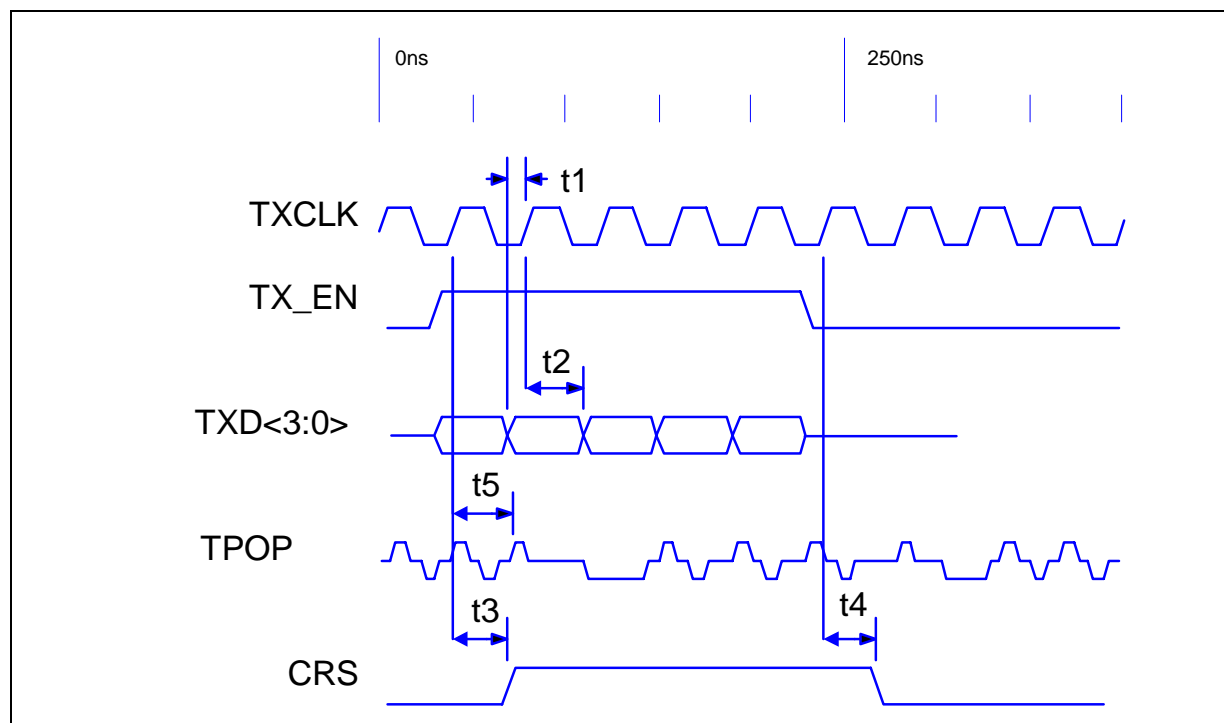

Table 32. MII - 100BASE-TX Transmit Timing Parameters

Parameter	Sym	Min	Typ ¹	Max	Units
TXD<3:0>, TX_EN, TX_ER setup to TX_CLK High	t1	10	–	–	ns
TXD<3:0>, TX_EN, TX_ER hold from TX_CLK High	t2	0	-1	–	ns
TX_EN sampled to CRS asserted	t3	–	2	4	BT
TX_EN sampled to CRS de-asserted	t4	–	3	16	BT
TX_EN sampled to TPOP out (Tx latency)	t5	6	9	14	BT

1. Typical values are at 25 °C and are for design aid only; not guaranteed and not subject to production testing.

Figure 28. MII - 100BASE-FX Receive Timing

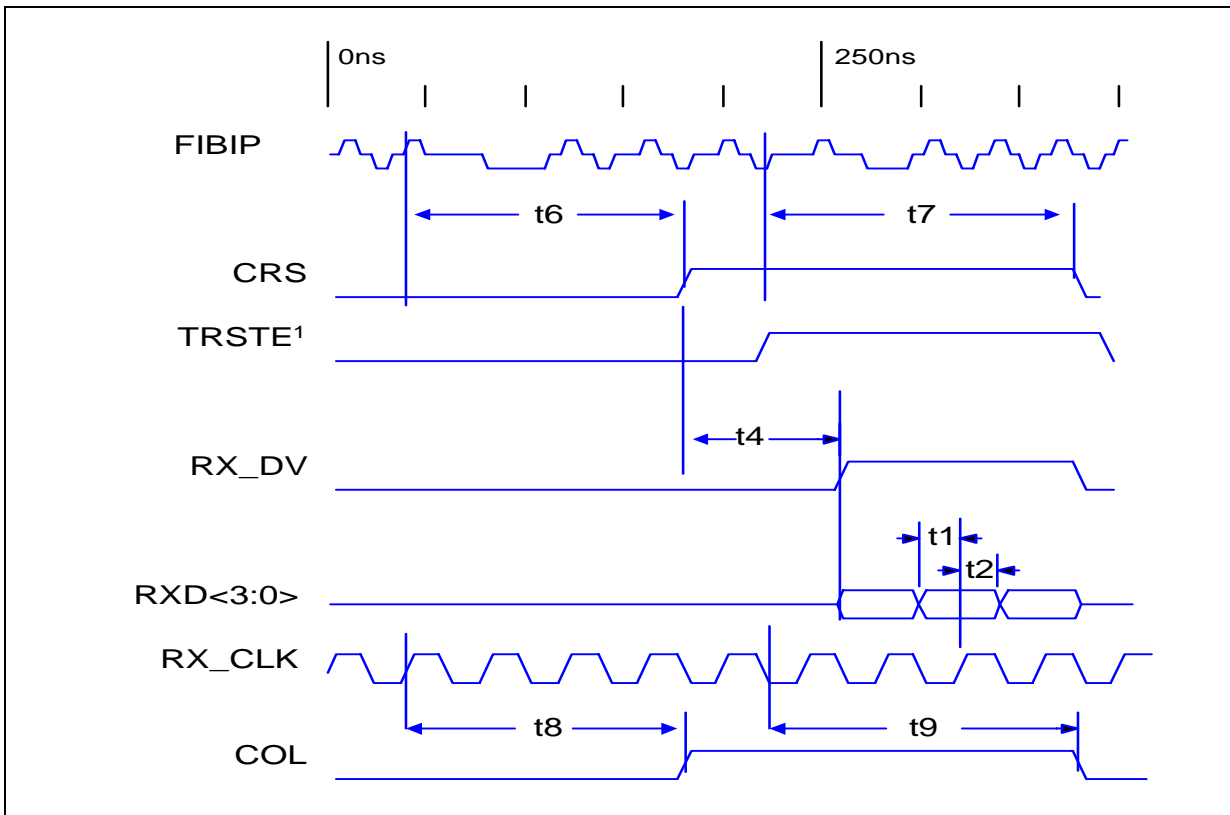

Table 33. MII - 100BASE-FX Receive Timing Parameters

Parameter	Sym	Min	Typ ¹	Max	Units
RXD, RX_DV, RX_ER setup to RX_CLK High	t1	10	–	–	ns
RXD, RX_DV, RX_ER hold from RX_CLK High	t2	5	–	–	ns
CRS asserted to RXD<3:0>, RX_DV asserted	t4	–	8	–	BT
Receive start of "J" to CRS asserted	t6	0	13 - 17	20	BT
Receive start of "T" to CRS de-asserted	t7	13	21 - 25	26	BT
Receive start of "J" to COL asserted	t8	0	13 - 17	20	BT
Receive start of "T" to COL de-asserted	t9	13	21 - 25	26	BT

1. Typical values are at 25 °C and are for design aid only; not guaranteed and not subject to production testing.

Figure 29. MII - 100BASE-FX Transmit Timing

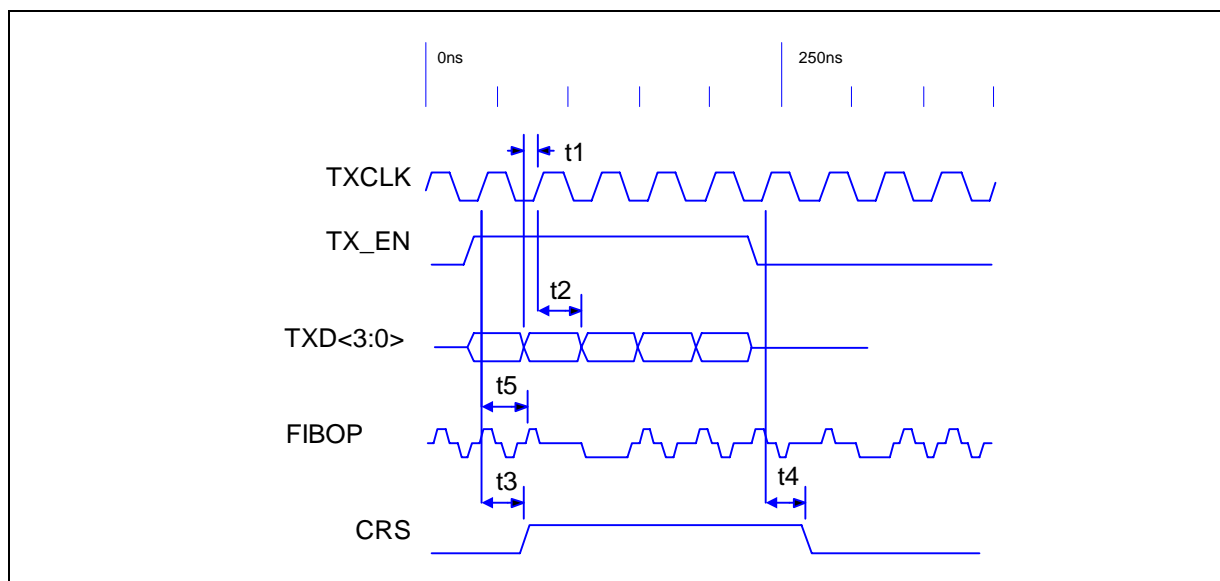

Table 34. MII - 100BASE-FX Transmit Timing Parameters

Parameter	Sym	Min	Typ ¹	Max	Units
TXD<3:0>, TX_EN, TX_ER setup to TX_CLK High	t1	10	–	–	ns
TXD<3:0>, TX_EN, TX_ER hold from TX_CLK High	t2	0	-1	–	ns
TX_EN sampled to CRS asserted	t3	–	2	4	BT
TX_EN sampled to CRS de-asserted	t4	–	3	16	BT
TX_EN sampled to FIBOP out (Tx latency)	t5	6	11	14	BT

1. Typical values are at 25 °C and are for design aid only; not guaranteed and not subject to production testing.

Figure 30. MII - 10BASE-T Receive Timing

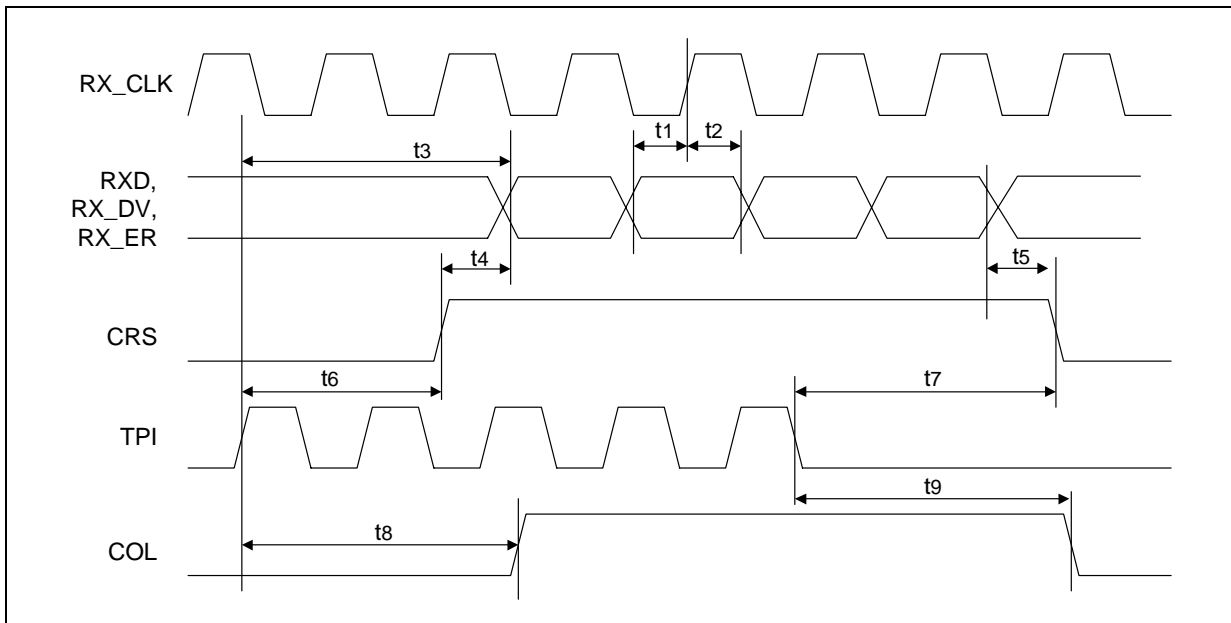

Table 35. MII - 10BASE-T Receive Timing Parameters

Parameter	Sym	Min	Typ ¹	Max	Units
RXD, RX_DV, RX_ER setup to RX_CLK High	t1	10	–	–	ns
RXD, RX_DV, RX_ER hold from RX_CLK High	t2	10	–	–	ns
TPI in to RXD out (Rx latency)	t3	–	–	73 ²	BT
CRS asserted to RXD, RX_DV, RX_ER asserted	t4	0	–	69 ²	BT
RXD, RX_DV, RX_ER de-asserted to CRS de-asserted	t5	0	2.5 - 5.5	6	BT
TPI in to CRS asserted	t6	0	4	5	BT
TPI quiet to CRS de-asserted	t7	0	18	19	BT
TPI in to COL asserted	t8	0	4	5	BT
TPI quiet to COL de-asserted	t9	0	18	19	BT

1. Typical values are at 25 °C and are for design aid only; not guaranteed and not subject to production testing.
 2. CRS is asserted. RXD/RX_DV are driven at the start of SFD (64 BT).

Figure 31. MII - 10BASE-T Transmit Timing

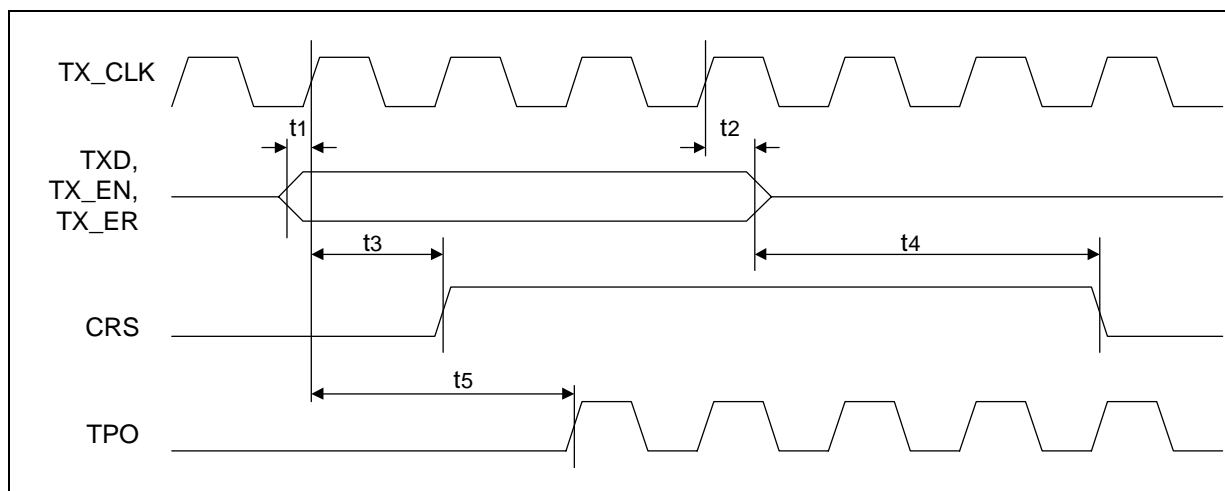

Table 36. MII - 10BASE-T Transmit Timing Parameters

Parameter	Sym	Min	Typ ¹	Max	Units
TXD, TX_EN, TX_ER setup to TX_CLK High	t1	10	–	–	ns
TXD, TX_EN, TX_ER hold from TX_CLK High	t2	0	-1	–	ns
TX_EN sampled to CRS asserted	t3	–	2	4	BT
TX_EN sampled to CRS de-asserted	t4	–	8-11	–	BT
TX_EN sampled to TPO out (Tx latency)	t5	–	3 - 5	–	BT

1. Typical values are at 25 °C and are for design aid only; not guaranteed and not subject to production testing.

Figure 32. 10BASE-T SQE (Heartbeat) Timing

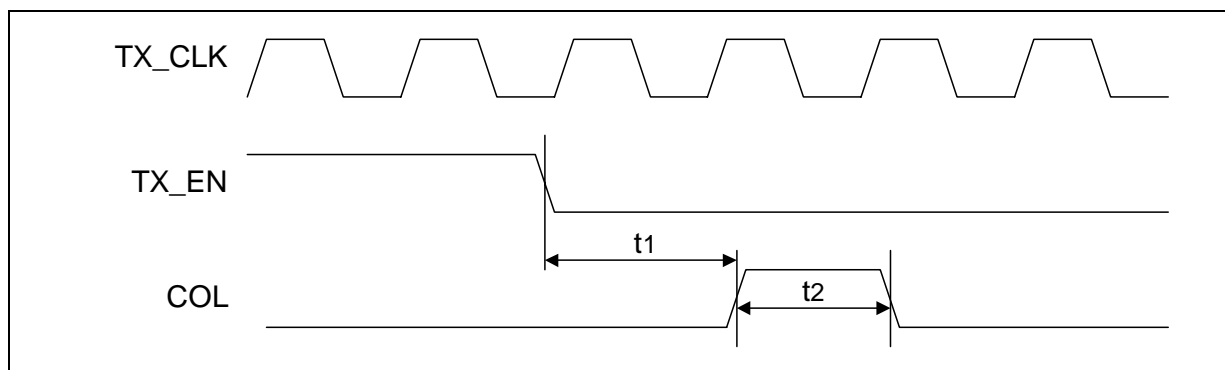

Table 37. 10BASE-T SQE (Heartbeat) Timing Parameters

Parameter	Sym	Min	Typ ¹	Max	Units
COL (SQE) delay after TX_EN off	t1	0.65	1.0	1.6	μs
COL (SQE) pulse duration	t2	.5	1.0	1.5	μs

1. Typical values are at 25 °C and are for design aid only; not guaranteed and not subject to production testing.

Figure 33. 10BASE-T Jab and Unjab Timing

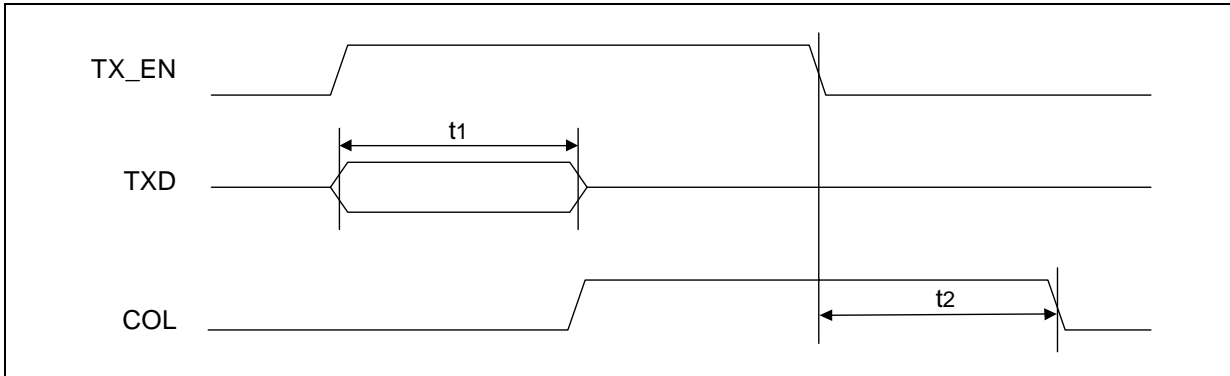

Table 38. 10BASE-T Jab and Unjab Timing Parameters

Parameter	Sym	Min	Typ ¹	Max	Units
Maximum transmit time	t1	20	96 - 128 ²	150	ms
Unjab time	t2	250	525	750	ms

1. Typical values are at 25 °C and are for design aid only; not guaranteed and not subject to production testing.
 2. Typical transmit time may be either of these values depending on internal 32 ms clock synchronization.

Figure 34. Auto Negotiation and Fast Link Pulse Timing

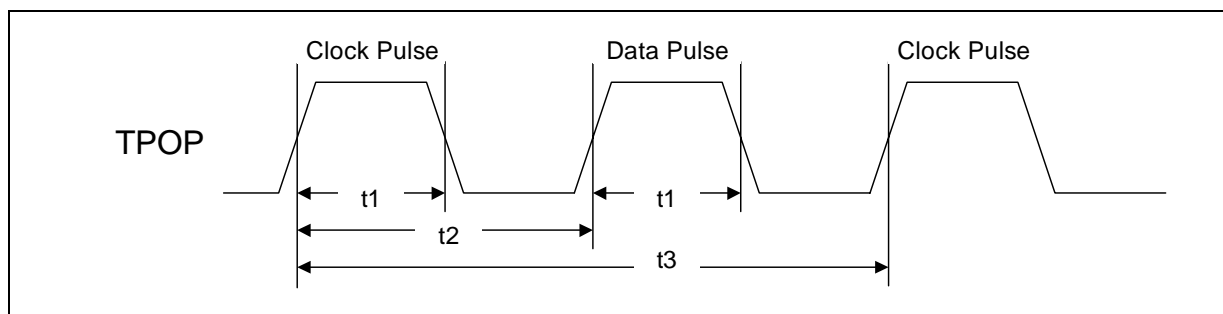

Figure 35. Fast Link Pulse Timing

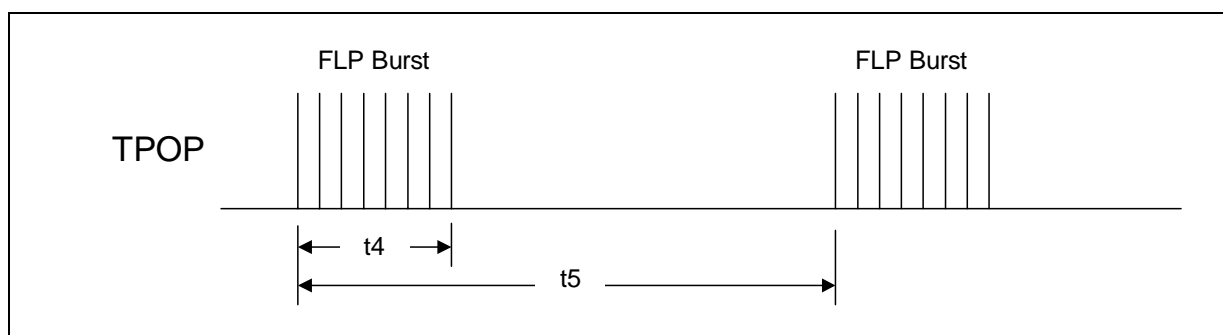

Table 39. Auto Negotiation and Fast Link Pulse Timing Parameters

Parameter	Sym	Min	Typ ¹	Max	Units
Clock/Data pulse width	t1	–	100	–	ns
Clock pulse to Data pulse	t2	55.5	62.5	69.5	μs
Clock pulse to Clock pulse	t3	111	125	139	μs
FLP burst width	t4	–	2	–	ms
FLP burst to FLP burst	t5	8	12	24	ms
Clock/Data pulses per burst	–	17	–	33	ea
1. Typical values are at 25 °C and are for design aid only; not guaranteed and not subject to production testing.					

Figure 36. MDIO Timing when Sourced by STA

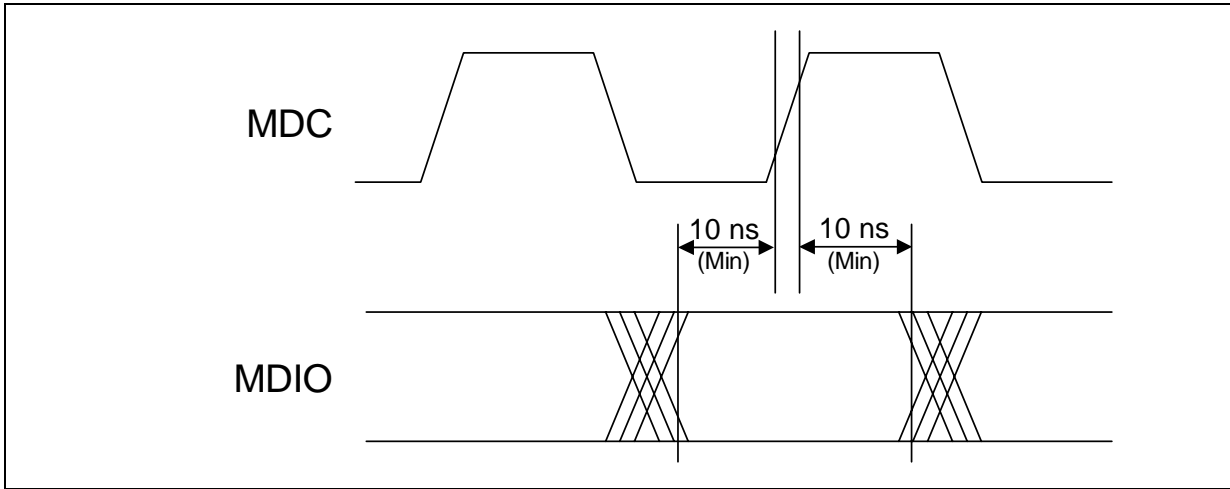

Figure 37. MDIO Timing When Sourced by PHY

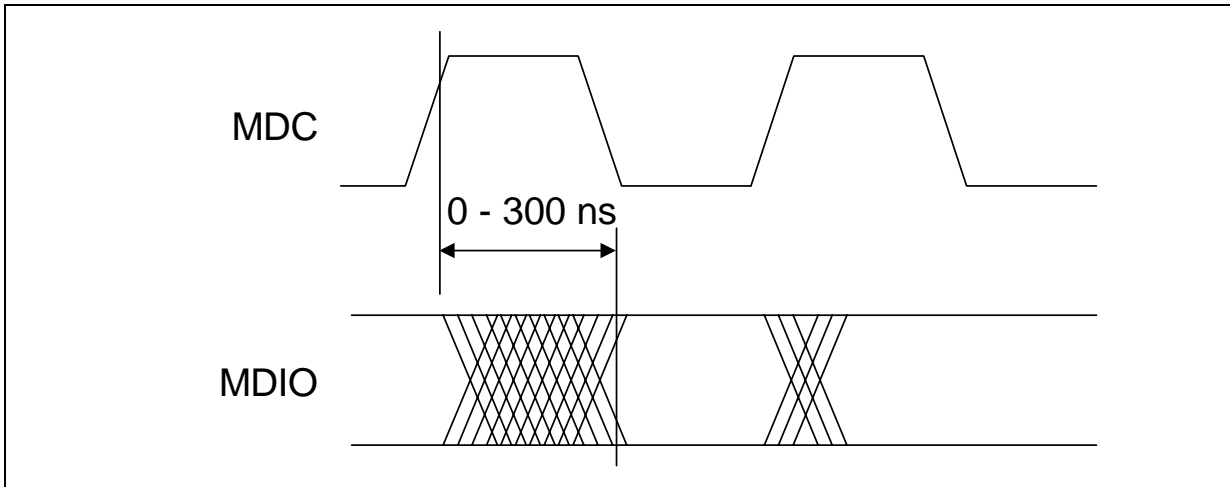

Table 40. MII Timing Parameters

Parameter	Sym	Min	Typ ¹	Max	Units	Test Conditions
MDIO setup before MDC	–	10	–	–	ns	When sourced by STA
MDIO hold after MDC	–	10	–	–	ns	When sourced by STA
MDC to MDIO output delay	–	0	27	300	ns	When sourced by PHY

1. Typical values are at 25° C and are for design aid only; not guaranteed and not subject to production testing.

Figure 38. Power Down Timing

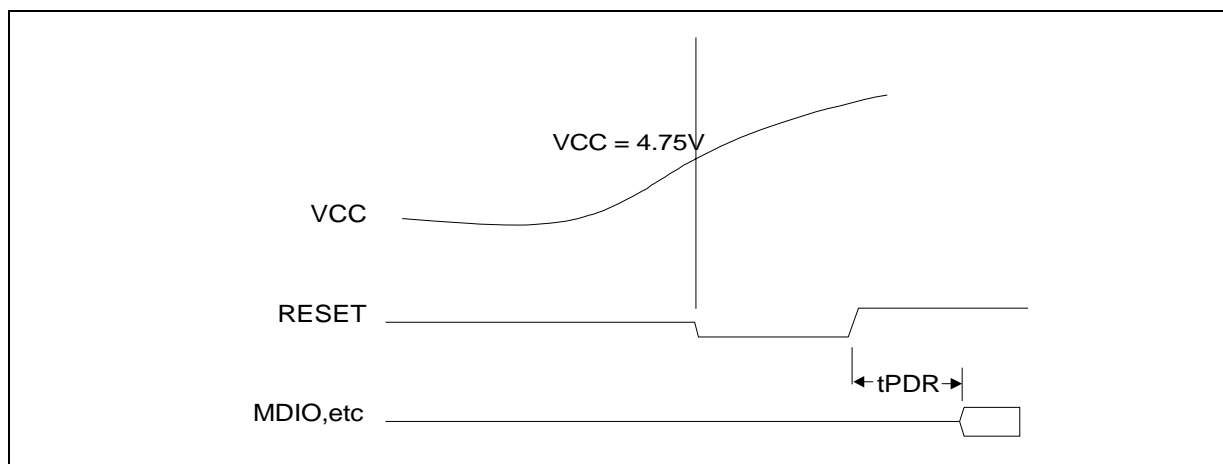

Table 41. Power Down Timing Parameters

Parameter	Sym	Min	Typ ¹	Max	Units
Power Down recovery time	tPDR	–	50	–	ms
1. Typical values are at 25° C and are for design aid only; not guaranteed and not subject to production testing.					

Figure 39. Serial LED Timing

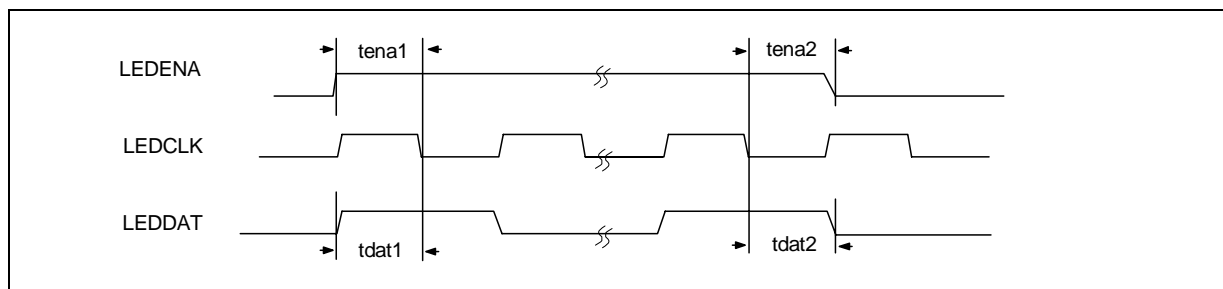

Table 42. Serial LED Timing Parameters

Parameter	Symbol	Min	Typ ¹	Max	Units
LEDENA setup to LEDCLK falling edge	tena1	5	12	–	ns
LEDENA hold from LEDCLK falling edge	tena2	15	21	–	ns
LEDDAT setup to LEDCLK falling edge	tdat1	5	12	–	ns
LEDDAT hold from LEDCLK falling edge	tdat2	15	21	–	ns
1. Typical values are at 25° C and are for design aid only; they are not guaranteed and not subject to production testing.					

5.0 Register Definitions

The LXT974/975 register set includes a total of 48 16-bit registers, 12 registers per port. Refer to [Table 43](#) for a complete register listing.

- Seven base registers (0 through 6) are defined in accordance with the “Reconciliation Sublayer and Media Independent Interface” and “Physical Layer Link Signaling for 10/100 Mbps Auto-Negotiation” sections of the IEEE 802.3 specification (Register 7, Next Page, is not supported).
- Five additional registers (16 through 20) are defined in accordance with the IEEE 802.3 specification for adding unique chip functions.

Table 43. Register Set

Address	Register Name	Bit Assignments
0	Control Register	Refer to Table 44 on page 64
1	Status Register	Refer to Table 45 on page 65
2	PHY Identification Register 1	Refer to Table 46 on page 66
3	PHY Identification Register 2	Refer to Table 47 on page 66
4	Auto-Negotiation Advertisement Register	Refer to Table 48 on page 67
5	Auto-Negotiation Link Partner Ability Register	Refer to Table 49 on page 67
6	Auto-Negotiation Expansion Register	Refer to Table 50 on page 68
16	LED Configuration Register	Refer to Table 51 on page 68
17	Interrupt Enable Register	Refer to Table 52 on page 69
18	Interrupt Status Register	Refer to Table 53 on page 70
19	Port Configuration Register	Refer to Table 54 on page 70
20	Port Status Register	Refer to Table 55 on page 71

Table 44. Control Register

Bit	Name	Description	Type ¹	Default
0.15	Reset	1 = Reset port. 0 = Enable normal operation.	R/W SC	0
0.14	Loopback	1 = Enable loopback mode. 0 = Disable loopback mode.	R/W	0
0.13	Speed Selection	1 = 100 Mbps. 0 = 10 Mbps.	R/W	Note 2
0.12	Auto-Negotiation Enable	1 = Enable auto-negotiate process (overrides speed select and duplex mode bits). 0 = Disable auto-negotiate process.	R/W	Note 3
0.11	Power Down	1 = Enable power down. 0 = Enable normal operation.	R/W	Note 4
0.10	Isolate	1 = Electrically isolate port from MII. 0 = Normal operation.	R/W	Note 5
0.9	Restart Auto-Negotiation	1 = Restart auto-negotiation process. 0 = Normal operation.	R/W SC	Note 6
0.8	Duplex Mode	1 = Enable full-duplex. 0 = Enable half-duplex.	R/W	Note 7
0.7	Collision Test	1 = Enable COL signal test. 0 = Disable COL signal test.	R/W	Note 8
0.6:4	Transceiver Test Mode	Not supported.	RO	0
0.3	Master-Slave Enable	Not supported.	RO	0
0.2	Master-Slave Value	Not supported.	RO	0
0.1:0	Reserved	Write as 0; ignore on read.	R/W	N/A

1. R/W = Read/Write
RO = Read Only
SC = Self Clearing

2. If auto-negotiation is enabled, this bit is ignored. If auto-negotiation is disabled, the default value of bit 0.13 is determined by CFG_0.

3. If SD_T \bar{X} _n is tied High or to a 5V PECL input (FX Mode), the default value of bit 0.12 = 0. If SD_T \bar{X} _n is tied Low (TP Mode), the default value of bit 0.12 is determined by AUTOENA.

4. The LXT974/975 internally holds all set values of the configuration registers upon exiting power down mode. A delay of 500 ns minimum is required from the time power down is cleared until any register can be written.

5. The default value of bit 0.10 is determined by pin TRSTEN.

6. If auto-negotiation is enabled, the default value of bit 0.9 is determined by CFG_0.
If auto-negotiation is disabled, the bit is ignored.

7. If auto-negotiation is enabled, this bit is ignored. If auto-negotiation is disabled and the port is operating in TX mode, the default value of bit 0.8 is determined by pin FDE.
If auto-negotiation is disabled and the port is operating in FX mode, the default value of bit 0.8 is determined by pin FDE_FX.

8. This bit is ignored unless loopback is enabled (bit 0.14 = 1).

Table 45. Status Register (Address 1)

Bit	Name	Description	Type ¹	Default
1.15	100BASE-T4	Not supported.	RO	0
1.14	100BASE-X Full-Duplex	1 = Port able to perform full-duplex 100BASE-X.	RO	1
1.13	100BASE-X Half-Duplex	1 = Port able to perform half-duplex 100BASE-X.	RO	1
1.12	10 Mbps Full-Duplex	1 = Port able to operate at 10 Mbps in full-duplex mode.	RO	1
1.11	10 Mbps Half-Duplex	1 = Port able to operate at 10 Mbps in half-duplex mode.	RO	1
1.10	100BASE-T2 Full-Duplex	Not supported.	RO	0
1.9	100BASE-T2 Half-Duplex	Not supported.	RO	0
1.8	Reserved	Ignore on read.	RO	0
1.7	Master-Slave Configuration Fault	Not supported.	RO	0
1.6	MF Preamble Suppression	0 = Port will not accept management frames with preamble suppressed.	RO	0
1.5	Auto-Negotiation Complete	1 = Auto-negotiation process complete. 0 = Auto-negotiation process not complete.	RO	0
1.4	Remote Fault	1 = Remote fault condition detected. 0 = No remote fault condition detected.	RO/LH	0
1.3	Auto-Negotiation Ability	1 = Port is able to perform auto-negotiation.	RO	1
1.2	Link Status	1 = Link is up. 0 = Link is down.	RO/LL	0
1.1	Jabber Detect (10BASE-T Only)	1 = Jabber condition detected. 0 = No jabber condition detected.	RO/LH	0
1.0	Extended Capability	1 = Extended register capabilities.	RO	1
1. RO = Read Only LL = Latching Low LH = Latching High				

Table 46. PHY Identification Register 1 (Address 2)

Bit	Name	Description	Type ¹	Default
2.15:0	PHY ID Number	The PHY identifier composed of bits 3 through 18 of the OUI.	RO	7810 hex

1. RO = Read Only

Table 47. PHY Identification Register 2 (Address 3)

Bit	Name	Description	Type ¹	Default
3.15:10	PHY ID number	The PHY identifier composed of bits 19 through 24 of the OUI.	RO	000000
3.9:4	Manufacturer's model number	6 bits containing manufacturer's part number.	RO	000100 - LXT974 000101 - LXT975
3.3:0	Manufacturer's revision number	4 bits containing manufacturer's revision number.	RO	XXXX ²

1. RO = Read Only
2. Default will be 0011 for LXT974A/975A and 0100 for LXT974B/975B.

Figure 40. PHY Identifier Bit Mapping

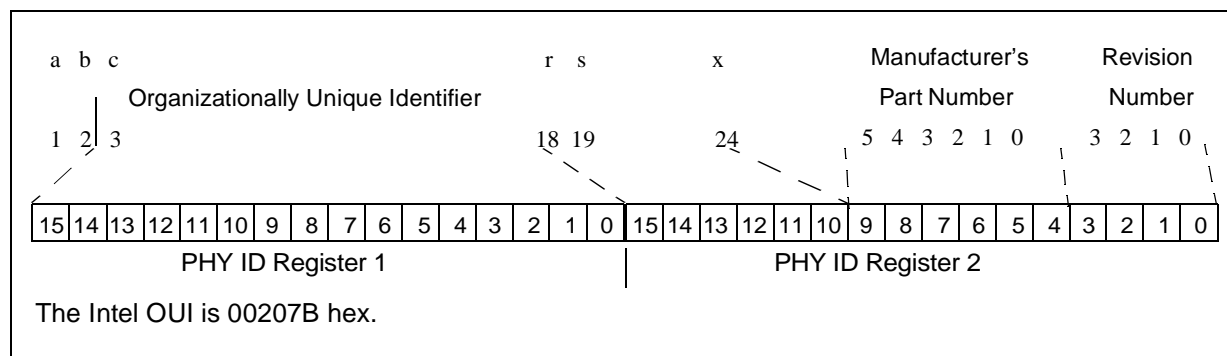

Table 48. Auto Negotiation Advertisement Register (Address 4)

Bit	Name	Description	Type ¹	Default
4.15	Next Page	Not supported.	RO	0
4.14	Reserved	Ignore.	RO	0
4.13	Remote Fault	1 = Remote fault. 0 = No remote fault.	R/W	0
4.12:11	Reserved	Ignore.	R/W	0
4.10	Pause	1 = Pause operation is enabled for full-duplex links. 0 = Pause operation is disabled.	R/W	0
4.9	100BASE-T4	1 = 100BASE-T4 capability is available. 0 = 100BASE-T4 capability is not available. (The LXT974/975 does not support 100BASE-T4 but allows this bit to be set to advertise in the Auto-Negotiation sequence for 100BASE-T4 operation. An external 100BASE-T4 transceiver could be switched in if this capability is desired.)	R/W	0
4.8	100BASE-TX full-duplex	1 = Port is 100BASE-TX full-duplex capable. 0 = Port is not 100BASE-TX full-duplex capable.	R/W	Note 2
4.7	100BASE-TX	1 = Port is 100BASE-TX capable. 0 = Port is not 100BASE-TX capable.	R/W	Note 3
4.6	10BASE-T full-duplex	1 = Port is 10BASE-T full-duplex capable. 0 = Port is not 10BASE-T full-duplex capable.	R/W	Note 4
4.5	10BASE-T	1 = Port is 10BASE-T capable. 0 = Port is not 10BASE-T capable.	R/W	Note 5
4.4:0	Selector Field, S<4:0>	<00001> = IEEE 802.3. <00010> = IEEE 802.9 ISLAN-16T. <00000> = Reserved for future Auto-Negotiation development. <11111> = Reserved for future Auto-Negotiation development. Unspecified or reserved combinations should not be transmitted.	R/W	00001

1. R/W = Read/Write
RO = Read Only
2. The default value of bit 4.8 is determined by FDE ANDed with CFG_2.
3. The default value of bit 4.7 is determined by CFG_2.
4. The default value of bit 4.6 is determined by FDE AND'ed with CFG_1.
5. The default value of bit 4.5 is determined by CFG_1.

Table 49. Auto Negotiation Link Partner Ability Register (Address 5)

Bit	Name	Description	Type ¹	Default
5.15	Next Page	1 = Link Partner has ability to send multiple pages. 0 = Link Partner has no ability to send multiple pages.	RO	N/A
5.14	Acknowledge	1 = Link Partner has received Link Code Word from LXT974/975. 0 = Link Partner has not received Link Code Word from the LXT974/975.	RO	N/A
5.13	Remote Fault	1 = Remote fault. 0 = No remote fault.	RO	N/A
5.12:11	Reserved	Ignore.	RO	N/A

1. RO = Read Only

Table 49. Auto Negotiation Link Partner Ability Register (Address 5) (Continued)

Bit	Name	Description	Type ¹	Default
5.10	Pause	1 = Pause operation is enabled for link partner. 0 = Pause operation is disabled.	RO	N/A
5.9	100BASE-T4	1 = Link Partner is 100BASE-T4 capable. 0 = Link Partner is not 100BASE-T4 capable.	RO	N/A
5.8	100BASE-TX full-duplex	1 = Link Partner is 100BASE-TX full-duplex capable. 0 = Link Partner is not 100BASE-TX full-duplex capable.	RO	N/A
5.7	100BASE-TX	1 = Link Partner is 100BASE-TX capable. 0 = Link Partner is not 100BASE-TX capable.	RO	N/A
5.6	10BASE-T full-duplex	1 = Link Partner is 10BASE-T full-duplex capable. 0 = Link Partner is not 10BASE-T full-duplex capable.	RO	N/A
5.5	10BASE-T	1 = Link Partner is 10BASE-T capable. 0 = Link Partner is not 10BASE-T capable.	RO	N/A
5.4:0	Selector Field S<4:0>	<00001> = IEEE 802.3. <00010> = IEEE 802.9 ISLAN-16T. <00000> = Reserved for future Auto-Negotiation development. <11111> = Reserved for future Auto-Negotiation development. Unspecified or reserved combinations shall not be transmitted.	RO	N/A

1. RO = Read Only

Table 50. Auto Negotiation Expansion (Address 6)

Bit	Name	Description	Type ¹	Default
6.15:5	Reserved	Ignore on read.	RO	0
6.4	Parallel Detection Fault	1 = Parallel detection fault has occurred. 0 = Parallel detection fault has not occurred.	RO/ LH	0
6.3	Link Partner Next Page Able	1 = Link partner is next page able. 0 = Link partner is not next page able.	RO	0
6.2	Next Page Able	Not supported.	RO	0
6.1	Page Received	1 = Three identical and consecutive link code words have been received from link partner. 0 = Three identical and consecutive link code words have not been received from link partner.	RO LH	0
6.0	Link Partner A/N Able	1 = Link partner is auto-negotiation able. 0 = Link partner is not auto-negotiation able.	RO	0

1. RO = Read Only LH = Latching High

Table 51. LED Configuration Register (Address 16, Hex 10)

Bit	Name	Description	Type ¹	Default
16.15:12	User Defined	No effect on chip operation.	R/W	N/A
16.11:9	Reserved	Ignore on read.	RO	N/A
16.8	TX Pulse Tuning	1 = Faster rise time - May be used to adjust output pulse to match magnetic performance. 0 = Normal Operation - Provides best match for most magnetics.	R/W	0

1. R/W = Read /Write

Table 51. LED Configuration Register (Address 16, Hex 10)

Bit	Name	Description	Type ¹	Default
16.7:6	LED_2 Select	Determine condition indicated by LED_2	R/W	0 0
		bit 7 bit 6 Indication Setting		
		0 0 LED _{n_2} indicates Link		
		0 1 LED _{n_2} indicates Half-Duplex Status		
		1 0 LED _{n_2} indicates 100 Mbps		
1 1 LED _{n_2} indicates Collision				
16.5:4	LED_1 Select	Determine condition indicated by LED_1	R/W	0 0
		bit 5 bit 4 Indication Setting		
		0 0 LED _{n_1} indicates Receive Activity		
		0 1 LED _{n_1} indicates Link		
		1 0 LED _{n_1} indicates Half-Duplex Status		
1 1 LED _{n_1} indicates 100 Mbps				
16.3:2	LED_0 Select	Determine condition indicated by LED_0	R/W	0 0
		bit 3 bit 2 Indication Setting		
		0 0 LED _{n_0} indicates Transmit Activity		
		0 1 LED _{n_0} indicates Receive Activity		
		1 0 LED _{n_0} indicates Link		
1 1 LED _{n_0} indicates Half-Duplex Status				
16.1	Link Algorithm	1 = Enhanced link algorithm - Link goes down when 12 idle symbols in a row are not received within 1 to 2 ms. 0 = Standard link algorithm - Link goes down when symbol error rate is greater than 64/1024.	R/W	0
16.0	LED Extension	1 = Disable extension of LED active time for LED _{n_<2:0>} . 0 = Enable extension of LED active time for LED _{n_<2:0>} .	R/W	0
1. R/W = Read /Write				

Table 52. Interrupt Enable Register (Address 17, Hex 11)

Bit	Name	Description	Type ¹	Default
17.15:2	Reserved	Write as 0; ignore on read.	R/W	N/A
17.1	INTEN	1 = Enable interrupts. Must be enabled for bit 17.0 or 19.12 to be effective. 0 = Disable interrupts.	R/W	0
17.0	TINT	1 = Forces MDINT Low and sets bit 18.15 = 1. Also forces interrupt pulse on MDIO when bit 19.12 = 1. 0 = Normal operation. This bit is ignored unless the interrupt function is enabled (17.1 = 1).	R/W	0
1. R/W = Read /Write				

Table 53. Interrupt Status Register (Address 18, Hex 12)

Bit	Name	Description	Type ¹	Default
18.15	MINT	1 = Indicates MII interrupt pending. 0 = Indicates no MII interrupt pending. This bit is cleared by reading Register 1 followed by reading Register 18.	RO	N/A
18.14:0	Reserved	Ignore	RO	0

1. RO = Read Only

Table 54. Port Configuration Register (Address 19, Hex 13)

Bit	Name	Description	Type ¹	Default
19.15	Reserved	Write as 0; ignore on read.	R/W	N/A
19.14	Txmit Test Enable (10BASETX)	1 = 100BASE-T transmit test enabled (Port transmits data regardless of receive status). 0 = Normal operation.	R/W	0
19.13	Reserved	Write as 0; ignore on read.	R/W	N/A
19.12	MDIO_INT	1 = Enable interrupt signaling on MDIO (if 17.1 = 1). 0 = Normal operation (MDIO Interrupt disabled). Bit is ignored unless the interrupt function is enabled (17.1 = 1).	R/W	0
19.11	TP Loopback Enable (10BASE-T)	1 = Disable 10BT Loopback - Data transmitted by the MAC will not loopback to the RXD and RX_DV pins. Only CRS is looped back. 0 = Enable 10BT Loopback - Preamble, SFD, and data are directly looped back to the MII.	R/W	0
19.10	SQE Disable (10BASE-T)	1 = Normal operation (SQE enabled). 0 = Disable SQE.	R/W	0
19.9	Jabber Disable (10BASE-T)	1 = Disable jabber. 0 = Normal operation (jabber enabled).	R/W	0
19.8	Link Test Enable (10BASE-T)	1 = Disable 10BASE-T link integrity test. 0 = Normal operation (10BASE-T link integrity test enabled).	R/W	Note 2
19.7:6	Reserved	Write as 0; ignore on read.	R/W	N/A
19.5	Advance TX Clock	1 = TX clock is advanced relative to TXD<3:0> and TX_ER by 1/2 TX_CLK cycle. 0 = Normal operation.	R/W	0
19.4	Reserved	Write as 0; ignore on read.	R/W	N/A

1. R/W = Read/Write
2. If auto-negotiation is disabled, the default value of bit 19.8 is determined by pin 115 (CFG_1). If CFG_1 is High, the default value of bit 19.8 = 1.
If CFG_1 is Low, the default value of bit 19.8 = 0. If auto-negotiation is enabled, the default value of bit 19.8 = 0.
3. The default value of bit 19.3 is determined by BYPSCR. If BYPSCR is High, the default value of bit 19.3 = 1.
If BYPSCR is Low, the default value of bit 19.3 = 0.
4. The default value of bit 19.2 is determined by the SD/TP_n pin for the respective port.
If SD/TP_n is tied Low, the default value of bit 19.2 = 0. If SD/TP_n is not tied Low, the default value of bit 19.2 = 1.
On the LXT975, this bit is ignored on ports 0 and 2 that operate in twisted-pair mode only.

Table 54. Port Configuration Register (Address 19, Hex 13) (Continued)

Bit	Name	Description	Type ¹	Default
19.3	Scrambler Bypass (100BASE-T only)	1 = Bypass transmit scrambler and receive descrambler. 0 = Normal operation (scrambler and descrambler enabled).	R/W	Note 3
19.2	100BASE-FX	1 = Enable 100BASE fiber interface. 0 = Enable 100BASE twisted pair interface.	R/W	Note 4
19.1	Reserved	Write as 0; ignore on read.	R/W	0
19.0	Transmit Disconnect	1 = Disconnect TP transmitter from line. 0 = Normal operation.	R/W	0

1. R/W = Read/Write
2. If auto-negotiation is disabled, the default value of bit 19.8 is determined by pin 115 (CFG_1). If CFG_1 is High, the default value of bit 19.8 = 1.
If CFG_1 is Low, the default value of bit 19.8 = 0. If auto-negotiation is enabled, the default value of bit 19.8 = 0.
3. The default value of bit 19.3 is determined by BYPSCR. If BYPSCR is High, the default value of bit 19.3 = 1.
If BYPSCR is Low, the default value of bit 19.3 = 0.
4. The default value of bit 19.2 is determined by the SD/TP_n pin for the respective port.
If SD/TP_n is tied Low, the default value of bit 19.2 = 0. If SD/TP_n is not tied Low, the default value of bit 19.2 = 1.
On the LXT975, this bit is ignored on ports 0 and 2 that operate in twisted-pair mode only.

Table 55. Port Status Register (Address 20, Hex 14)

Bit	Name	Description	Type ¹	Default
20.15:14	Reserved	Write as 0, ignore on read.	R/W	N/A
20.13	Link	1 = Link is up. 0 = Link is down. Link bit 20.13 is a duplicate of bit 1.2, except that it is a dynamic indication, whereas bit 1.2 latches Low.	RO	0
20.12	Duplex Mode	1 = Full-Duplex. 0 = Half-Duplex.	RO	Note 2
20.11	Speed	1 = 100 Mbps operation. 0 = 10 Mbps operation.	RO	Note 2
20.10	Reserved	Ignore.	RO/LH	N/A
20.9	Auto-Negotiation Complete	1 = Auto-negotiation process complete. 0 = Auto-negotiation process not complete. Auto-Negotiation Complete bit 20.9 is a duplicate of bit 1.5.	RO/LH	0
20.8	Page Received	1 = Three identical and consecutive link code words received. 0 = Three identical and consecutive link code words not received. Page Received bit 20.8 is a duplicate of bit 6.1.	RO/LH	0
20:7	Reserved	Write as 0, ignore on read.	R/W	0
20.6	Stream cipher lock (100BASE-TX only)	1 = Stream cipher locked. 0 = Stream cipher not locked.	RO	0
20.5	Symbol Error	1 = Symbol error detected. 0 = No symbol error detected.	RO/LH	N/A

1. R/W = Read /Write
RO = Read Only
LH = Latching High
2. Bits 20.12 and 20.11 reflect the current operating mode of the LXT974/975.

Table 55. Port Status Register (Address 20, Hex 14) (Continued)

Bit	Name	Description	Type ¹	Default
20.4	MLT3 Encoding Error	1 = MLT3 encoding error detected. 0 = No MLT3 encoding error detected.	RO/ LH	N/A
20.3	Reserved	Ignore.	RO	N/A
20.2	Low-Voltage Fault	1 = Low-voltage fault on VCC has occurred. 0 = No fault.	RO/ LH	N/A
20.1	Reserved	Write as 0, ignore on read.	R/W	N/A
20.0	Reserved	Ignore.	RO/ LH	N/A
1. R/W = Read /Write RO = Read Only LH = Latching High 2. Bits 20.12 and 20.11 reflect the current operating mode of the LXT974/975.				

6.0 Package Specification

Figure 41. LXT974/975 Package Specification

160-Pin PQFP with Heat Spreader

- (Commercial Temp 0 - 70°C)
- Part Number LXT974AHC
- Part Number LXT975AHC
- Part Number LXT974BHC
- Part Number LXT975BHC

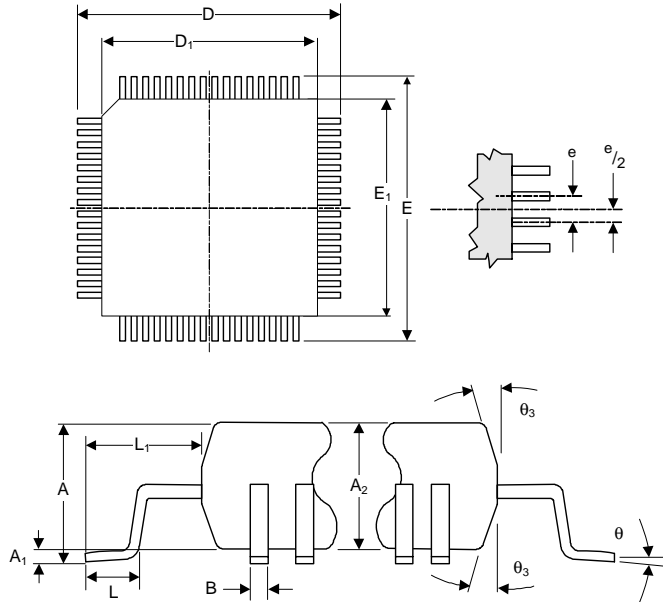

Table 56. QUAD FLAT PACKAGE

Dim.	All Dimensions in millimeters			Notes
	Min.	Typ.	Max.	
A	---	3.70	4.07	
A ₁	0.25	0.33	---	
A ₂	3.20	3.37	3.60	
D	31.20 BSC			5
D ₁	28.00 BSC			6, 7, 8
E	31.20 BSC			5
E ₁	28.00 BSC			6, 7, 8
L	0.73	0.88	1.03	
M	---	---	---	
b	0.22	---	0.38	8
e	0.65 BSC			

NOTE:

1. All dimensions are in millimeters.
2. This package conforms to JEDEC publication 95 registration MS-022, variation DD-1.
3. Datum plane -H- located at mold parting line and is coincident with leads where leads exit plastic body at bottom of parting line.
4. Measured at seating plane -C-.
5. Measured at datum plane -H-.
6. Dimensions D₁ and E₁ do not include mold protrusion. Allowable mold protrusion is 0.254 mm.
7. Package top dimensions are smaller than bottom dimensions. Top of package will not overhang bottom of package.
8. Dimension b does not include dambar protrusion. Allowable dambar protrusion is no more than 0.08 mm.

6.1 Top Label Markings

Figure 42 shows a sample HQFP package for the LXT974/975 Transceiver.

Note: In contrast to the Pb-Free (RoHS-compliant) HQFP package, the non-RoHS-compliant packages do not have the “e3” symbol in the last line of the package label.

Figure 42. Sample HQFP Package – Intel® HBLXT97xBHC Transceiver

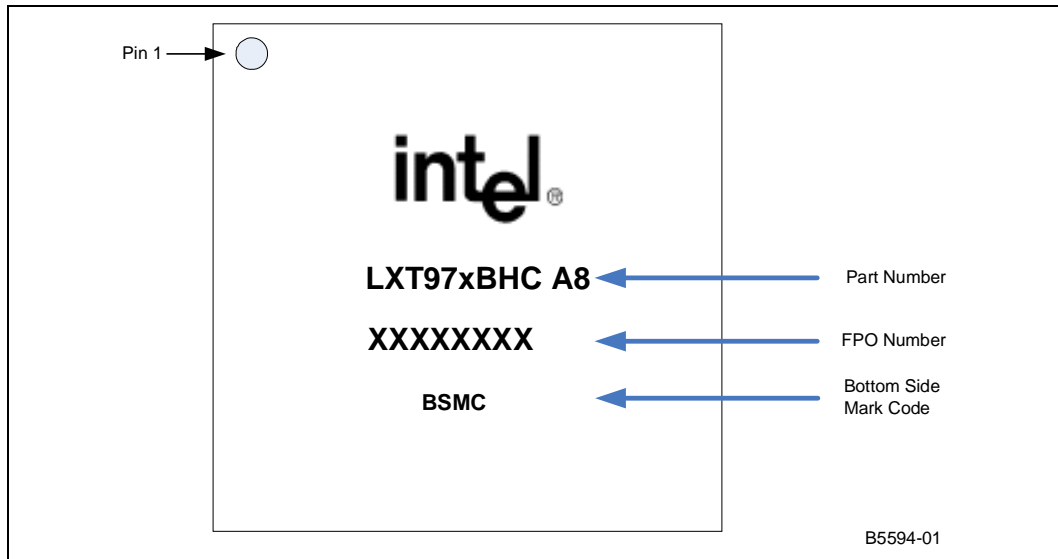
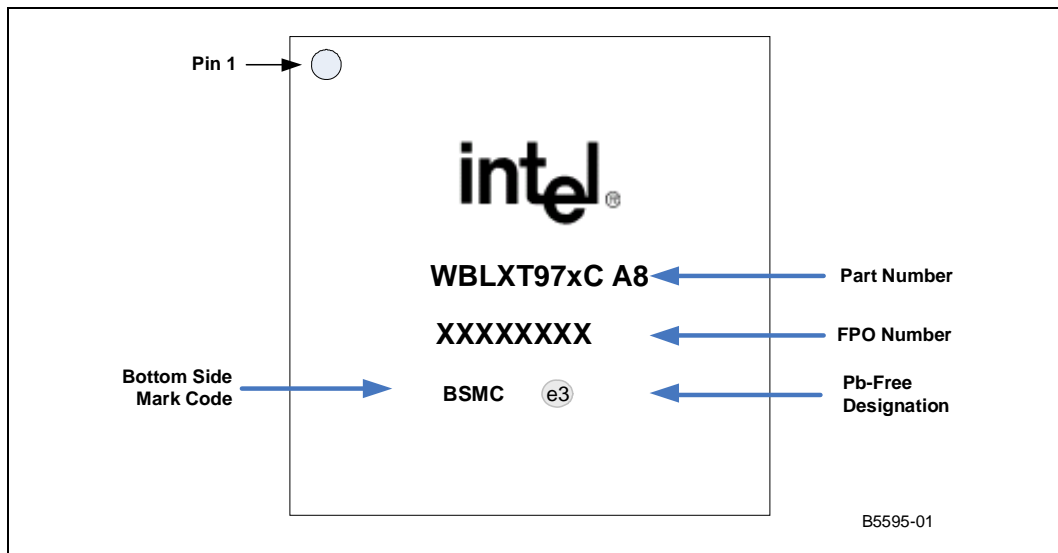

Figure 43 shows a sample Pb-free RoHS-compliant HQFP package for the LXT974/975 Transceiver.

Figure 43. Sample Pb-Free (RoHS-Compliant) HQFP Package – Intel® WBLXT97xBHC Transceiver



7.0 Ordering Information

Table 56 lists the LXT974/975 Transceiver product ordering information.

Table 56. Product Information

Intel Number	Revision	Package Type	Pin Count	RoHS Compliant
HBLXT974BHC	A8	HQFP	160	No
WBLXT974BHC	A8	HQFP	160	Yes
HBLXT975BHC	A8	HQFP	160	No
WBLXT975BHC	A8	HQFP	160	Yes

Figure 44 shows an order matrix with sample information for the LXT974/975 Transceiver.

Figure 44. Ordering Information Matrix – Sample

