

RIGHT ANGLE PLUG

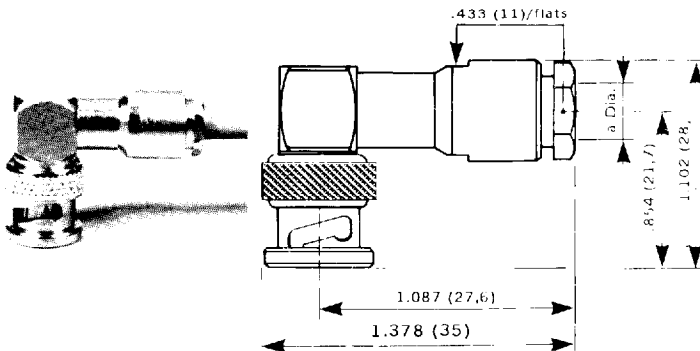

| | | | |
|-----------------|----------|--------------|------------|
| CABLE DIA. | Ω | $.102$ (2,6) | $.236$ (6) |
| | | 75 | 75 + 93 |
| PART NUMBER | | R 142 154 | R 142 157 |
| a dia. max. | | .118 (3) | .260 (6,6) |
| Captive contact | | YES | YES |
| Assembly | | M 04 | M 02 |

SQUARE FLANGE JACK

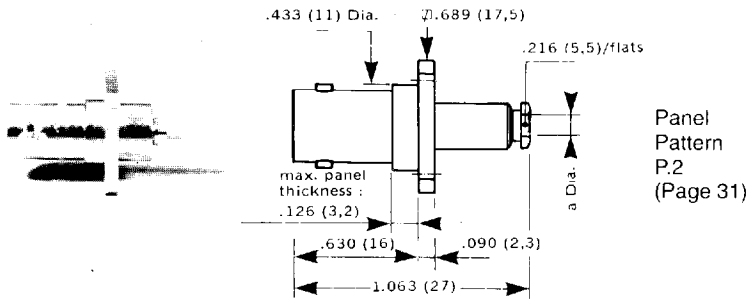

| | | | |
|-----------------|----------|---------------------------------------|----|
| CABLE DIA. | Ω | $.102$ (2,6) | 75 |
| | | | |
| PART NUMBER | | R 142 202 | |
| a dia. max. | | .118 (3) | |
| Captive contact | | NO | |
| Flange holes | | 4 holes N° 3.56 UNF.2B (M 2,5 x 0,45) | |
| Assembly | | M 10 | |

SQUARE FLANGE JACK

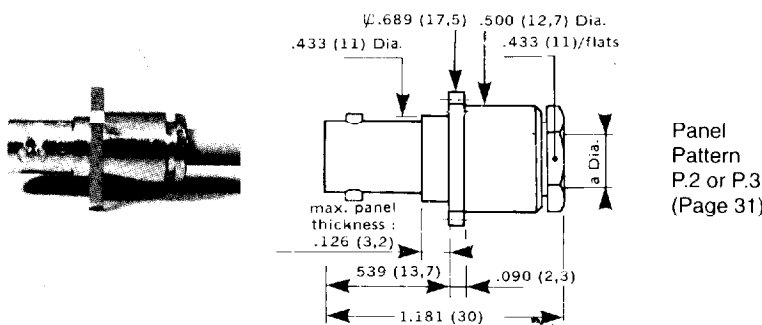

| | | | |
|-----------------|----------|---------------------------------------|---------|
| CABLE DIA. | Ω | $.236$ (6) | 75 + 93 |
| | | | |
| PART NUMBER | | R 142 268 | |
| Equival. MIL | | UG. 262 D/U | |
| a dia. max. | | .256 (6,5) | |
| Captive contact | | NO | |
| Flange holes | | 4 holes N° 3.56 UNF.2B (M 2,5 x 0,45) | |
| Assembly | | M 02 | |

BULKHEAD JACK

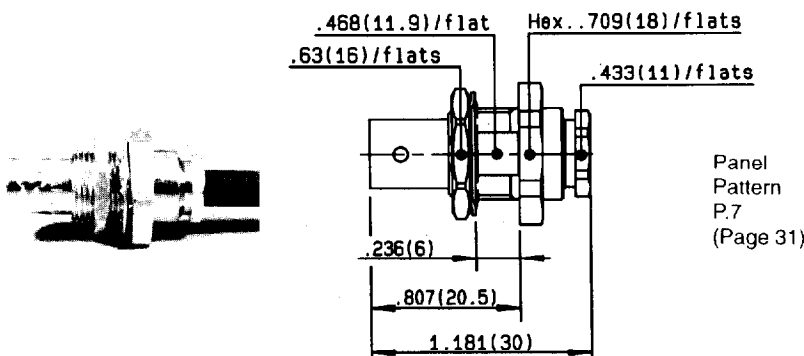

| | | | |
|-----------------|----------|------------|---------|
| CABLE DIA. | Ω | $.236$ (6) | 75 + 93 |
| | | | |
| PART NUMBER | | R 142 329 | |
| a dia. max. | | .260 (6,6) | |
| Captive contact | | YES | |
| Assembly | | M 02 | |