

DATA SHEET

Part No.	AN6784
Package Code No.	SIP007-P-0000I

Maintenance/Discontinued
(planned maintenance type, maintenance type, planned discontinued type, discontinued type)
Maintenance/Discontinued includes following four Product lifecycle stage.

Contents

■ Overview	3
■ Features	3
■ Applications	3
■ Package	3
■ Type	3
■ Application Circuit Example / Block Diagram	4
■ Pin Descriptions	6
■ Absolute Maximum Ratings	7
■ Operating Supply Voltage Range	7
■ Current and Voltage Range	8
■ Electrical Characteristics	9
■ Electrical Characteristics (Reference values for design)	10
■ Electrical Characteristics Test Procedures	11
■ Technical Data	12
■ Usage Notes	13

Maintenancel
Discontinued
Maintenance/Discontinued includes following four Product lifecycle stage.
(planned maintenance type, maintenance type, planned discontinued type, discontinued type)

AN6784

IC for long interval timer

■ Overview

AN6784 is an IC designed for long interval timer. It is oscillated by using the external resistor and capacitor, and the oscillation frequency divided by a 15-stage F.F is provided as the output.

It is frequency divider type, so that a long interval timer can be constructed by using a capacitor with small capacitance.

■ Features

- Oscillation frequency dispersion of IC itself is small ($\pm 5\%$)
- Wide operating supply voltage range (3.2 V to 18 V)
- Small consumption current (3 mA typ.)

■ Applications

- Long interval timer

■ Package

- 7 pin Plastic Single Inline Package (SIP Type)

■ Type

- Silicon monolithic bipolar IC

Maintenance/Discontinued

Maintenance/Discontinued includes following four Product lifecycle stage.
(planned maintenance type, maintenance type, planned discontinued typed, discontinued type)

■ Application Circuit Example / Block Diagram

1. Ultra low frequency oscillation circuit

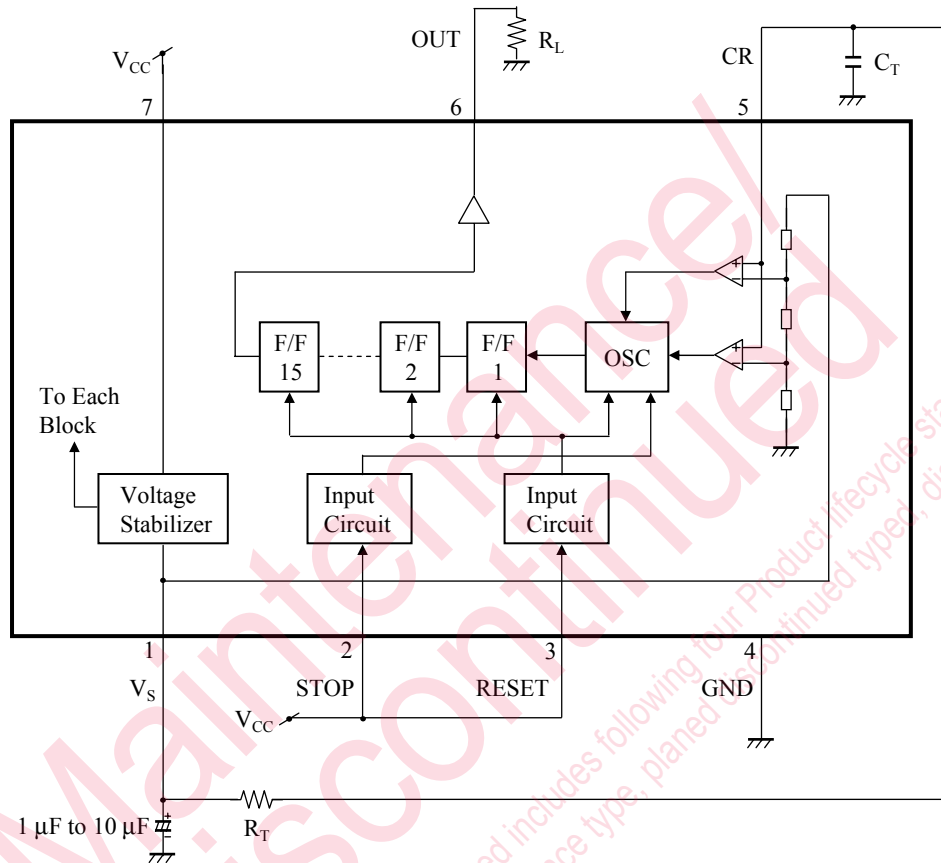

- Oscillation frequency
 $t_0(\text{S}) \cong 0.947R_T(\Omega) \cdot C_T(\text{F})$
- Output period
 $t_2(\text{S}) \cong t_0 \times 32\,768 \cong 31.03R_T(\text{k}\Omega) \cdot C_T(\mu\text{F})$

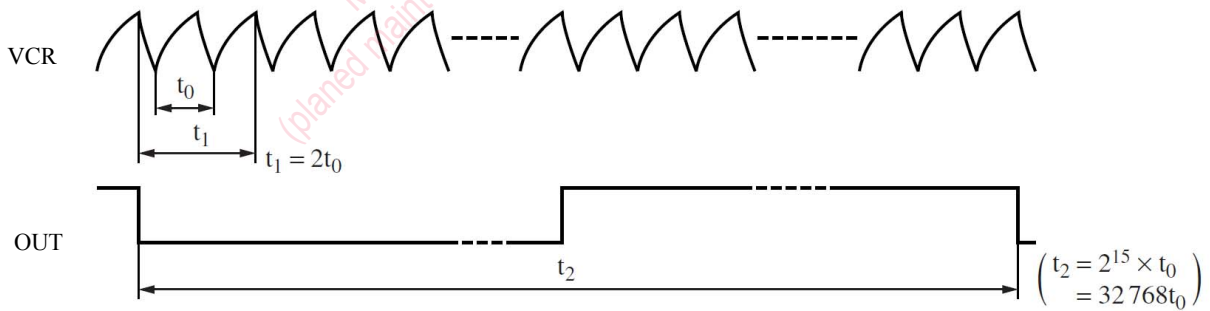

■ Application Circuit Example/Block Diagram (continued)
 2. Timer

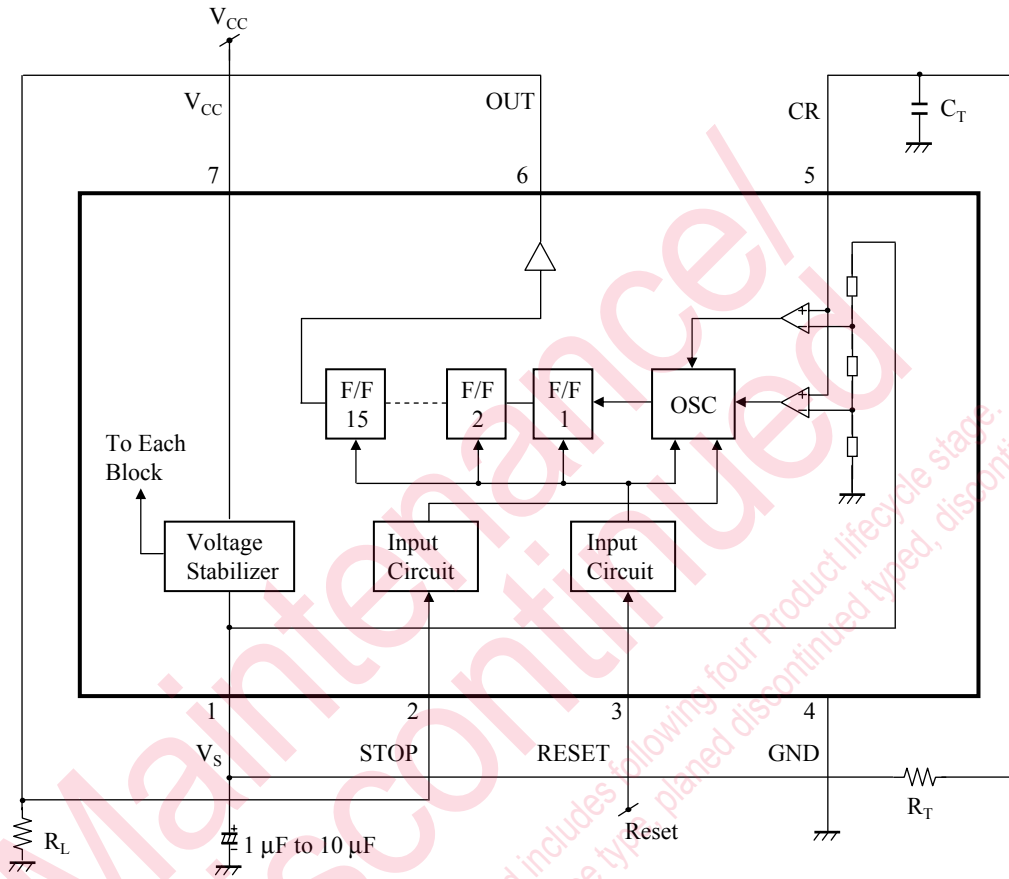

• Timer interval
 $t_2(S) \cong 16\,384t_0 \cong 16\,384 \times 0.947R_T(\Omega) \cdot C_T(F) \cong 15.52R_T(k\Omega) \cdot C_T(\mu F)$

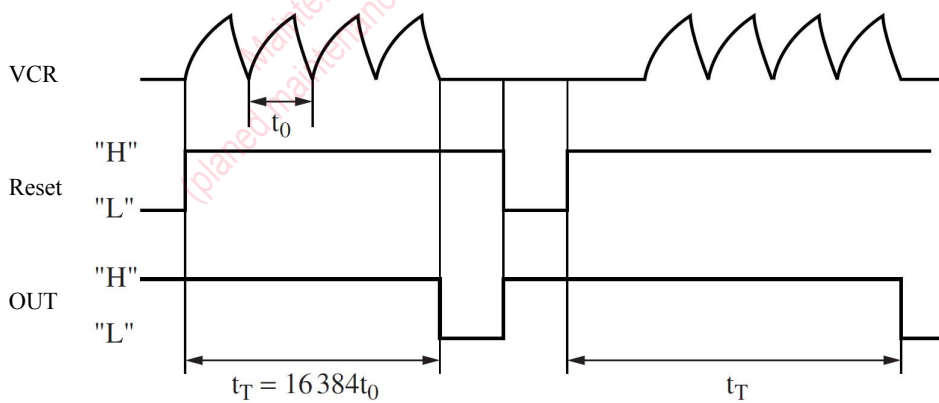

■ Pin Descriptions

Pin No.	Pin name	Type	Descriptions
1	V _S	Output	Reference voltage
2	STOP	Input	Oscillation stop input
3	RESET	Input	Reset input
4	GND	Ground	GND
5	CR	—	C, R connection
6	OUT	Output	Output
7	V _{CC}	Power supply	Power supply

Maintenance/Discontinued
(planned maintenance type, maintenance type, planned discontinued type, discontinued type)
Maintenance/Discontinued includes following four Product lifecycle stage.

■ Absolute Maximum Ratings

A No.	Parameter	Symbol	Rating	Unit	Notes
1	Supply voltage	V_{CC}	20	V	*1
2	Supply current	I_{CC}	7	mA	—
3	Power dissipation	P_D	140	mW	—
4	Operating ambient temperature	T_{opr}	-35 to +85	°C	*2
5	Storage temperature	T_{stg}	-55 to +150	°C	*2

Notes) *1: The values under the condition not exceeding the above absolute maximum ratings and the power dissipation.

*2: Except for the power dissipation, operating ambient temperature, and storage temperature, all ratings are for $T_a = 25^\circ\text{C}$.

■ Operating supply voltage range

Parameter	Symbol	Range	Unit	Notes
Supply voltage range	V_{CC}	3.2 to 18.0	V	*

Note) *: The values under the condition not exceeding the above absolute maximum ratings and the power dissipation.

■ Current and Voltage Range

Notes) Do not apply external currents or voltages to any pin not specifically mentioned.

For the circuit currents, '+' denotes current flowing into the IC, and '-' denotes current flowing out of the IC.

Pin No.	Symbol	Rating	Unit	Note
2	STOP	0 to 18	V	
3	RESET	0 to 18	V	
5	CR	0 to 3	V	

Pin No.	Symbol	Rating	Unit	Note
6	OUT	-15 to +15	mA	

Maintenance/Discontinued!

Maintenance/Discontinued includes following four Product lifecycle stage.
(planned maintenance type, maintenance type, planned discontinued type, discontinued type)

■ Electrical Characteristics

Note) $T_a = 25^\circ\text{C} \pm 2^\circ\text{C}$ unless otherwise specified.

B No.	Parameter	Symbol	Test circuits	Conditions	Limits			Unit	Notes
					Min	Typ	Max		
1	Quiescent supply current	I_{CC}	1	$V_{CC} = 5\text{ V}$	2.0	4.0	5.0	mA	
2	Internal reference voltage	V_S	2	$V_{CC} = 5\text{ V}, I_S = -3\text{ mA}$	2.40	2.55	2.70	V	
3	High-level input current	I_{IH}	3	$V_{CC} = 18\text{ V}, V_{IH} = 18\text{ V}$	—	—	10	μA	
4	Low-level input current	I_{IL}	4	$V_{CC} = 18\text{ V}, V_{IL} = 0\text{ V}$	-100	—	—	μA	
5	High-level OUT pin voltage	V_{OH}	5	$V_{CC} = 18\text{ V}, I_{OH} = -10\text{ mA}$	14.0	16.0	18.0	V	
6	Low-level OUT pin voltage	V_{OL}	6	$V_{CC} = 3.2\text{ V}, I_{OL} = 10\text{ mA}$	—	—	0.4	V	
7	Oscillation frequency precision	f_{OSC}	7	$V_{CC} = 5\text{ V}, R_T = 1\text{ k}\Omega$ $C_T = 0.1\text{ }\mu\text{F}$	9.0	9.5	10.0	kHz	
8	Oscillation frequency fluctuation with supply voltage	Δf_v	7	3.2 V to 5V or 5V to 18 V	-5.0	—	+5.0	%	
9	High-level input voltage	V_{IH}	8	$V_{CC} = 5\text{ V}$	2.0	—	—	V	
10	Low-level input voltage	V_{IL}	8	$V_{CC} = 5\text{ V}$	—	—	0.8	V	

■ Electrical Characteristics (Reference values for design)

Note) $T_a = 25^\circ\text{C} \pm 2^\circ\text{C}$ unless otherwise specified.

B No.	Parameter	Symbol	Test circuits	Conditions	Reference values			Unit	Notes
					Min	Typ	Max		
11	Oscillation frequency-temperature dependency	Δf_r	7	$V_{CC} = 5 \text{ V}$, $R_T = 1 \text{ k}\Omega$ $C_T = 0.1 \text{ }\mu\text{F}$	-5.0	—	+5.0	%	*1

Note) The data show the changing amount within $T_a = -30^\circ\text{C}$ to $+85^\circ\text{C}$ when the values at $T_a = +25^\circ\text{C}$ is taken as the reference.

The above characteristics are reference values for design of the IC and are not guaranteed by inspection.

If a problem does occur related to these characteristics, Panasonic will respond in good faith to user concerns.

Maintenance/Discontinued

Maintenance/Discontinued includes following four Product lifecycle stage.
(planned maintenance type, maintenance type, planned discontinued type, discontinued type)

■ Electrical Characteristics Test Procedures

• Truth Table

Mode	VRESET	VSTOP	Oscillation(VCR)	frequency division:(count)	VOUT
Reset	L	—	Stop(H)	Cleared	H
Stop	H	L	Stop(H)	Stop Holds the previous state	Stop Holds the previous state
Operation	H	H	Oscillation	Counting	1/32768-frequency division pulse output

Maintenance/Discontinued

Maintenance/Discontinued includes following four Product lifecycle stage.
(planned maintenance type, maintenance type, planned discontinued type, discontinued type)

■ Technical Data

- I/O block circuit diagrams and pin function descriptions

Note) The characteristics listed below are reference values based on the IC design and are not guaranteed.

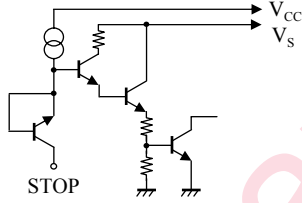
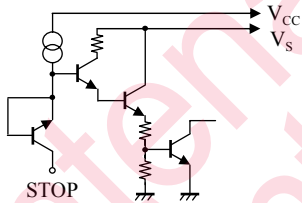
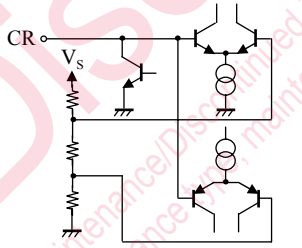
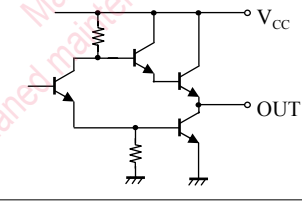
Pin No.	Pin name	DC voltage	Internal circuit	Description
1	V _S	2.55 V	—	Stabilized power supply output pin. Reference voltage source for oscillation circuit
2	STOP	—		Oscillation stop input pin. Only the oscillation circuit stops when this pin becomes low-level. (F.F. is not cleared) When not used, this pin should be open or connected to V _{CC} .
3	RESET	—		Reset input pin F.F. is reset when the pin becomes low-level and is set in the initial state. When not used, this pin should be open or connected to V _{CC} . The reset is applied by rising V _{CC} from a voltage below 0.8 V (power-on reset function)
4	GND	0 V	—	GND pin
5	CR	0.7 V to 1.8 V		Capacitor and resistor connection pin The oscillation period is determined by an external resistor and capacitor. When applying a pulse to this pin from the outside the voltage should be within the range of 0 V to 3 V.
6	OUT	High level V _{CC} -1.4 V Low level < 0.4 V		Output pin. A frequency which is 1/32768 of the oscillation frequency is output. Should be used with output current within ±10 mA
7	V _{CC}	—	—	Supply voltage pin

■ Usage Notes

Pay attention to the followings in order to prevent the destruction during the use and to increase the reliability.

1. In the application circuit example, the calculated value by the theoretical equation for timer interval calculation and such matter of the above into consideration.
Also, the proportional constant "a" depends on the kinds and characteristics of the time interval and time interval capacitor. Make a final confirmation with the finished products.
In the case when a high precision is required, adjust the value by using a variable resistor as the time interval resistor.
2. Use a time interval resistor in the range of $1\text{k}\Omega$ to $1\text{M}\Omega$, and a time interval capacitor in the range of $0.1\ \mu\text{F}$ to $100\ \mu\text{F}$ which is polyester or tantalum electronic capacitor with a small $\tan\delta$ value.
3. Connect a capacitor ($1\ \mu\text{F}$ to $10\ \mu\text{F}$) to the V_S pin in order to protect the IC from an external noise and to stabilize its operation.
4. If turning on power again after an extremely short-time supply off state during the normal operation, be careful that there may be a case that the automatic reset (power-on reset) fails due to residual potential of the external capacitance.
5. Take measures against noise in order to prevent malfunction caused by external noise. Particularly, when setting a long interval, pay attention to the external noises.
6. When a plunger or relay is connected to the output circuit, connect diodes to both ends of the coil in order to protect the IC against counter electromotive power generated after power-off.
7. Do not short circuit the V_S pin with V_{CC} pin in order to avoid malfunction.

Request for your special attention and precautions in using the technical information and semiconductors described in this book

- (1) If any of the products or technical information described in this book is to be exported or provided to non-residents, the laws and regulations of the exporting country, especially, those with regard to security export control, must be observed.
- (2) The technical information described in this book is intended only to show the main characteristics and application circuit examples of the products. No license is granted in and to any intellectual property right or other right owned by Panasonic Corporation or any other company. Therefore, no responsibility is assumed by our company as to the infringement upon any such right owned by any other company which may arise as a result of the use of technical information described in this book.
- (3) The products described in this book are intended to be used for standard applications or general electronic equipment (such as office equipment, communications equipment, measuring instruments and household appliances).
Consult our sales staff in advance for information on the following applications:
 - Special applications (such as for airplanes, aerospace, automobiles, traffic control equipment, combustion equipment, life support systems and safety devices) in which exceptional quality and reliability are required, or if the failure or malfunction of the products may directly jeopardize life or harm the human body.
 - Any applications other than the standard applications intended.
- (4) The products and product specifications described in this book are subject to change without notice for modification and/or improvement. At the final stage of your design, purchasing, or use of the products, therefore, ask for the most up-to-date Product Standards in advance to make sure that the latest specifications satisfy your requirements.
- (5) When designing your equipment, comply with the range of absolute maximum rating and the guaranteed operating conditions (operating power supply voltage and operating environment etc.). Especially, please be careful not to exceed the range of absolute maximum rating on the transient state, such as power-on, power-off and mode-switching. Otherwise, we will not be liable for any defect which may arise later in your equipment.
 - Even when the products are used within the guaranteed values, take into the consideration of incidence of break down and failure mode, possible to occur to semiconductor products. Measures on the systems such as redundant design, arresting the spread of fire or preventing glitch are recommended in order to prevent physical injury, fire, social damages, for example, by using the products.
- (6) Comply with the instructions for use in order to prevent breakdown and characteristics change due to external factors (ESD, EOS, thermal stress and mechanical stress) at the time of handling, mounting or at customer's process. When using products for which damp-proof packing is required, satisfy the conditions, such as shelf life and the elapsed time since first opening the packages.
- (7) This book may be not reprinted or reproduced whether wholly or partially, without the prior written permission of our company.