

M5M81C56P-2/FP-2/J-2

CMOS 2048-BIT STATIC RAM WITH I/O PORTS AND TIMER

DESCRIPTION

The M5M81C56P-2 is the 2K-bit RAM (256-word by 8-bit) fabricated by the silicon gate CMOS technology. This LSI has 3 I/O ports and a 14-bit counter/timer which make it a good extension of the functions of an 8-bit microcomputer. It is housed in 40-pin plastic molded DIP.

And preparatory for surface equipment M5M81C56FP-2 (SOP) and M5M81C56J-2 (PLCC).

FEATURES

- Having internal anti-circuit on RESET and ALE
- Single 5V supply voltage
- TTL compatible
- Power down mode
- Timer input : 5MHz (max)
- Read access time : 120ns (max)
- Static RAM: 256-word by 8-bit
- Programmable 8-bit I/O port: 2
- Programmable 6-bit I/O port: 1
- Programmable counter/timer: 14-bit
- Multiplexed address/data bus

APPLICATION

Extension of I/O ports and timer function for microprocessor

FUNCTION

The M5M81C56P-2 is composed of RAM, I/O ports and counter/timer. The RAM is a 2K-bit static RAM organized as 256-word by 8-bit. The I/O ports consist of 2 programmable 8-bit ports and 1 programmable 6-bit port. The terminals of the 6-bit port can be programmed as control terminals for the 8-bit ports, so that the 8-bit ports can be operated in a handshake mode. The counter/timer is composed of 14-bit down counter (events or time) and it can generate square wave pulses that can be used for counting and timing.

PIN CONFIGURATION (TOP VIEW)

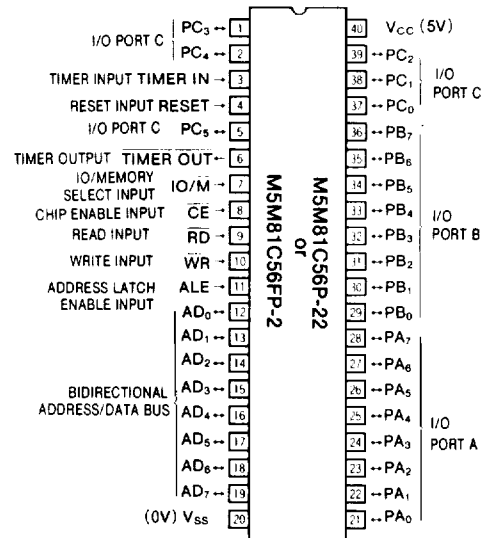

Outline 40P4 (M5M81C56P-2)
Outline 40P2R (M5M81C56FP-2)

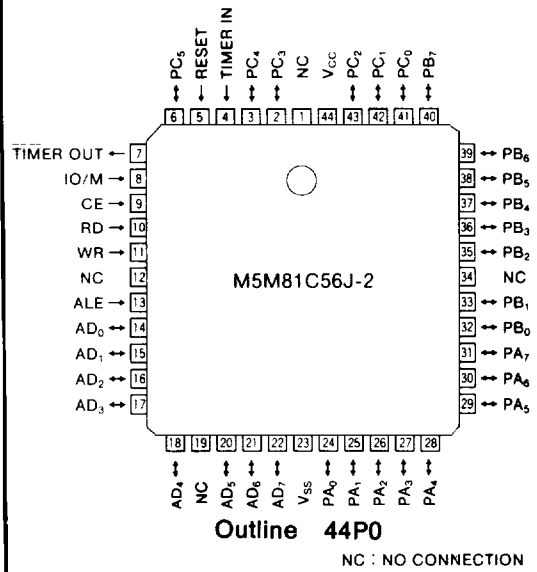

Outline 44P0
NC : NO CONNECTION

CMOS 2048-BIT STATIC RAM WITH I/O PORTS AND TIMER

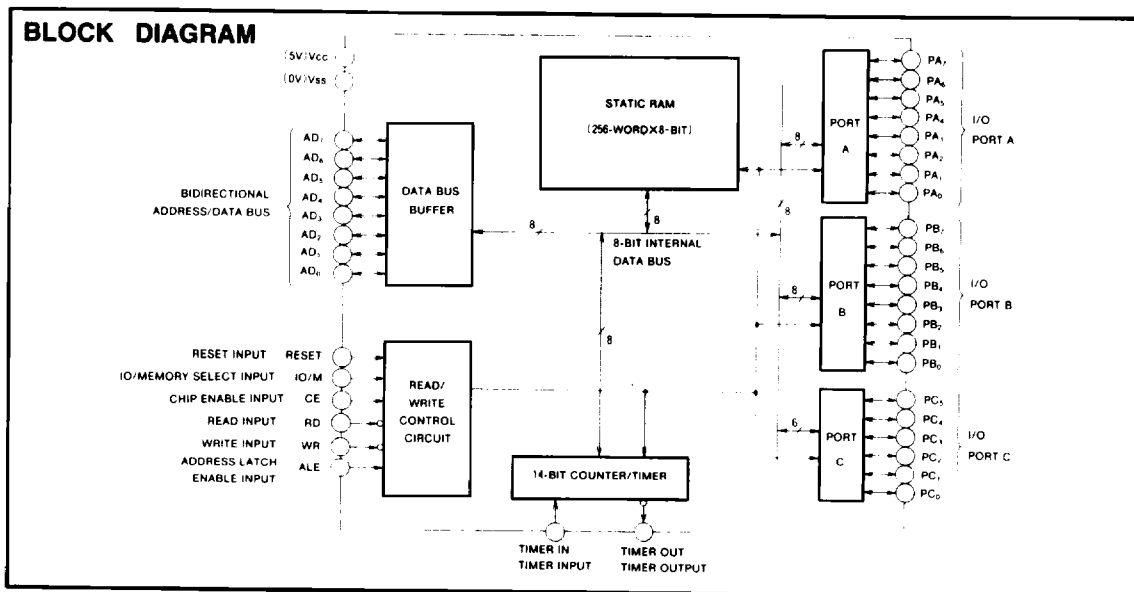

CMOS 2048-BIT STATIC RAM WITH I/O PORTS AND TIMER

OPERATION

Data Bus Buffer

This 3-state bidirectional 8-bit buffer is used to transfer the data while input or output instructions are being executed by the CPU. Command and address information is also transferred through the data bus buffer.

Read/Write Control Logic

The read/write control logic controls the transfer of data and commands by interpreting the signals (CE, \overline{RD} , \overline{WR} , IO/ \overline{M} , ALE, RESET) from CPU.

Bidirectional Address/Data Bus (AD₀~AD₇)

The bidirectional address/data bus is a 3-state 8-bit bus. The 8-bit address is latched in the internal latch by the falling edge of ALE. Then if IO/ \overline{M} input signal is at high-level, the address of I/O port, counter/timer, or command register is selected. If it is at low-level, address of RAM is selected. The 8-bit data is transferred by read input (\overline{RD}) or write input (\overline{WR}).

Chip Enable Input (CE)

When CE is at high-level, the address information on address/data bus is stored in the M5M81C56P-2.

Read Input (\overline{RD})

When \overline{RD} is at low-level, the data bus buffer is active. If IO/ \overline{M} input signal is at low-level, the contents of RAM are read through the address/data bus. If IO/ \overline{M} input is at high-level, the contents of selected I/O port or counter/timer are read through the address/data bus.

Write Input (\overline{WR})

When \overline{WR} is at low-level, the data on the address/data bus are written into RAM if IO/ \overline{M} is at low-level, or they are written into I/O port, counter/timer or command register if IO/ \overline{M} is at high-level.

Address Latch Enable Input (ALE)

An address on the address/data bus is latched in the M5M81C56P-2 on the falling edge of ALE along with the levels of CE and IO/ \overline{M} .

IO/Memory Input (IO/ \overline{M})

When IO/ \overline{M} is at low-level, the RAM is selected, while at high-level the I/O port, counter/timer or command register are selected.

I/O Port A (PA₀~PA₇)

Port A is an 8-bit general-purpose I/O port. Input/output setting is controlled by the system software.

I/O Port B (PB₀~PB₇)

Port B is an 8-bit general-purpose I/O port. Input/output setting is controlled by the system software.

I/O Port C (PC₀~PC₅)

Port C is a 6-bit I/O port that can also be used to output control signals of port A (PA) or port B (PB). The functions of port C are controlled by the system software. When port C is used to output control signals of ports A or B, the assignment of the signals to the pins is as shown in Table 1.

Table 1 Pin assignment of control signals of port C

Pin	Function
PC ₅	B STB (port B strobe)
PC ₄	B BF (port B buffer full)
PC ₃	B INTR (port B interrupt)
PC ₂	A STB (port A strobe)
PC ₁	A BF (port A buffer full)
PC ₀	A INTR (port A interrupt)

Timer Input (TIMER IN)

The signal on this input terminal is used by the counter/timer for counting events or time. (5MHz max.)

Timer Output (TIMER OUT)

A square wave signal or pulse from the counter/timer is output through this pin when in the operation mode.

Command Register (8-bit)

The command register is an 8-bit latched register. The low-order 4 bits (bits 0~3) are used for controlling and determination of mode of the ports. Bits 4 and 5 are used as interrupt enable flags for ports A and B when port C is used as a control port. Bits 6 and 7 are used for controlling the counter/timer. The contents of the command register are rewritten by output instructions (I/O address XXXX000).

Details of the functions of the individual bits of the command register are shown in Table 2.

Table 2 Bit functions of the command register

Bit	Symbol	Function
0	PA	PORT A I/O SET 1: Output port A 0: Input port A
1	PB	PORT B I/O SET 1: Output port B 0: Input port B
2	PC ₁	PORT C SET 00: ALT1 11: ALT2 01: ALT3 10: ALT4
3	PC ₂	
4	IEA	PORT A INTERRUPT ENABLE FLAG 1: Enable interrupt 0: Disable interrupt
5	IEB	PORT B INTERRUPT ENABLE FLAG 1: Enable interrupt 0: Disable interrupt
6	TM1	COUNTER/TIMER CONTROL 00: No influence on counter/timer operation 01: Counter/timer operation discontinued (if not already stopped) 10: Counter/timer operation discontinued after the current counter/timer operation is completed 11: Counter/timer operation started
7	TM2	

CMOS 2048-BIT STATIC RAM WITH I/O PORTS AND TIMER

Status Register (7-bit)

The status register is a 7-bit latched register. The low-order 6 bits (bits 0~5) are used as status flags for the I/O ports. Bit 6 is used as a status flag for the counter/timer. The con-

tents of the status register are transferred into the CPU by reading (INPUT instruction, I/O address XXXXX000). Details of the functions of the individual bits of the status register are shown in Table 3.

Table 3 Bit functions of the status register

Bit	Symbol	Function
0	INTR A	PORT A INTERRUPT REQUEST
1	A BF	PORT A BUFFER FULL FLAG
2	INTE A	PORT A INTERRUPT ENABLE
3	INTR B	PORT B INTERRUPT REQUEST
4	B BF	PORT B BUFFER FULL FLAG
5	INTE B	PORT B INTERRUPT ENABLE
6	TIMER	COUNTER/TIMER INTERRUPT <i>(This flag is set to 1 when the final limit of the counter/timer is reached and is reset to 0 when the status is read)</i>
7		This bit is not used

I/O PORTS

Command/status registers (8-bit/7-bit)

These registers are assigned address XXXXX000. When an OUTPUT command is executed, the contents of the command register are rewritten. When an INPUT command is executed, the contents of the status register are read.

Port A Register (8-bit)

Port A Register is assigned address XXXXX001. This register can be programmed as an input or output by setting the appropriate bits of the command register as shown in Table 2.

Port A can be operated in basic or strobe mode and is assigned I/O terminal PA₀~PA₇.

Port B Register (8-bit)

Port B register is assigned address XXXXX010. As with Port A register, this register can be programmed as an input or output by setting the appropriate bits of the command register as shown in Table 2. Port B can be operated in basic or strobe mode and is assigned I/O terminals PB₀~PB₇.

Port C Register (6-bit)

Port C register is assigned address XXXXX011. This port is used not only for input or output but also for controlling input/output operations of ports A and B by selectively setting bits 2 and 3 of the command register as shown in Table 2. Details of the functions of the various setting of bits 2 and 3 are shown in Table 4. Port C is assigned I/O terminals PC₀~PC₅. When used as port control signals, the 3 low-order bits are assigned for port A while the 3 high-order bits are assigned for port B.

Table 4 Functions of port C

State Terminal	ALT 1	ALT 2	ALT 3	ALT 4
PC ₅	Input	Output	Output	B STB (port B strobe)
PC ₄	Input	Output	Output	B BF (port B buffer full)
PC ₃	Input	Output	Output	B INTR (port B interrupt)
PC ₂	Input	Output	A STB (port A strobe)	A STB (port A strobe)
PC ₁	Input	Output	A BF (port A buffer full)	A BF (port A buffer full)
PC ₀	Input	Output	A INTR (port A interrupt)	A INTR (port A interrupt)

CMOS 2048-BIT STATIC RAM WITH I/O PORTS AND TIMER

CONFIGURATION OF PORTS

A block diagram of 1 bit of ports A or B is shown in Fig. 1. While port A or B is programmed as an output port, if the port is addressed by an input instruction, the contents of the selected port can be read. When a port is put in input mode, the output latch is cleared and writing into the output

latch is disabled. Therefore when a port is changed to output mode from input mode, low-level signals are output through the port. When a reset signal is applied, all 3 ports (PA, PB, and PC) will be input ports and their output latches are cleared. Port C has the same configuration as ports A and B in modes ALT1 and ALT2.

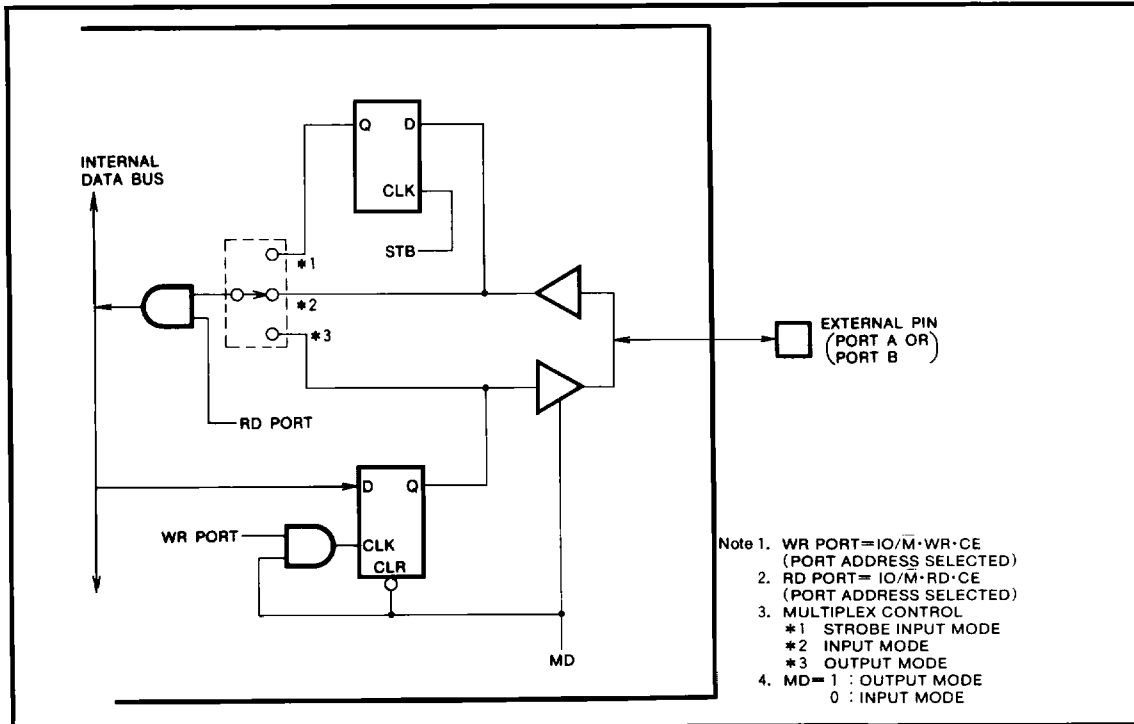

Fig. 1 Configuration for 1 bit of port A or B

Table 5 Basic functions of I/O ports

Address	RD	WR	Function
XXXXX000	L	H	AD bus ← Status register
	H	L	Command register ← AD bus
XXXXX001	L	H	AD bus ← Port A
	H	L	Port A ← AD bus
XXXXX010	L	H	AD bus ← Port B
	H	L	Port B ← AD bus
XXXXX011	L	H	AD bus ← Port C
	H	L	Port C ← AD bus

Table 6 Port control signal levels at ALT3 and ALT4

Control Signal	Output mode	Input mode
STB	Input	Input
BF	"L"	"L"
INTR	"H"	"L"

The basic functions of the I/O ports are shown in Table 5. The control signal levels to ports A and B, when port C is programmed as a control port, are shown in Table 6.

COUNTER/TIMER

The counter/timer is composed of a 14-bit counting register and 2 mode flags. The register has two sections: I/O address XXXXX100 is assigned to the low-order 8 bits and I/O address XXXXX101 is assigned to the high-order 6 bits and timer mode flag 2 bits. The low-order bits 0~13 are used for counting or timing. The counter is initialized by the program and then counted down to zero. The initial value can be ranged from 2₁₆ to 3FFF₁₆. Bits 14 and 15 are used as mode flags.

The mode flags select 1 of 4 modes with functions as follows:

- Mode 0: Outputs high-level signal during the former half of the counter operation
Outputs low-level signal during the latter half of the counter operation

CMOS 2048-BIT STATIC RAM WITH I/O PORTS AND TIMER

Table 7 Format of counter/timer

Address	Bit Number								Function
	7	6	5	4	3	2	1	0	
XXXXX100	T ₇	T ₆	T ₅	T ₄	T ₃	T ₂	T ₁	T ₀	The low-order 8 bits of the counter register
XXXXX101	M ₂	M ₁	T ₁₃	T ₁₂	T ₁₁	T ₁₀	T ₉	T ₈	M ₂ ,M ₁ : Timer mode T ₁₃ ~T ₈ : The high-order 6 bits of the counter register

- Mode 1: Outputs square wave signals as in mode 0
- Mode 2: Outputs a low-level pulse during the final count down
- Mode 3: Outputs a low-level pulse during each final count down

Starting and stopping the counter/timer is controlled by bits 6 and 7 of the command register (see Table 2 for details). The format and timer modes of the counter/timer register are shown in Table 7 and Table 8.

The contents of counter/timer is not affected by a reset, but counting is discontinued. To resume counting, a start command must be written into the command register as shown in Table 2. While operating 2n+1 count down in mode 0 and mode 1, a high-level signal is output during the former n+1 counting and a low-level signal is output during the latter n counting.

Table 8 Timer mode

M ₂	M ₁	Timer operation
0	0	Outputs high-level signal during the former half of the counter operation Outputs low-level signal during the latter half of the counter operation (mode 0)
0	1	Outputs square wave signals in mode 0 (mode 1)
1	0	Outputs a low-level pulse during the final count down (mode 2)
1	1	Outputs a low-level pulse during each final count down (mode 3)

RAM Hold Mode at Low Voltage (Power Down Mode)

Power down mode starts when the ALE input is fixed at low-level and other inputs at high or low-level after low-level of CE input in M5M81C56P-2 is latched by the falling edge of the ALE input.

The contents of RAM are not affected, even if V_{CC} falls into 2 V in power down mode.

RESET

The M5M81C56P-2 is reset by 400ns (min) pulse input on RESET pin.

By reset, all 3 ports are set to input mode. And counter/timer stops but contents of counter/timer is not reset. Therefore it is necessary to input start command again.

ABSOLUTE MAXIMUM RATINGS

Symbol	Parameter	Conditions	Ratings	Unit
V _{CC}	Supply voltage		-0.3~7	V
V _I	Input voltage	With respect to V _{SS}	-0.3~V _{CC} +0.3	V
V _O	Output voltage		-0.3~V _{CC} +0.3	V
I _{OHMAX}	MAX "H" Output current	All output and I/O pins output "H" level and force same current.	-500	μA
I _{OLMAX}	MAX "L" Output current	All output and I/O pins output "L" level and force same current.	2.5	mA
T _{opr}	Operating free-air temperature		-20~75	°C
T _{stg}	Storage temperature range		-65~150	°C

RECOMMENDED OPERATING CONDITIONS (T_a=-20~75°C unless otherwise noted)

Symbol	Parameter	Limits			Unit
		Min	Nom	Max	
V _{CC}	Supply voltage	4.5	5	5.5	V
V _{SS}	Supply voltage (GND)		0		V

CMOS 2048-BIT STATIC RAM WITH I/O PORTS AND TIMER

ELECTRICAL CHARACTERISTICS ($T_a = -20 \sim 75^\circ\text{C}$, $V_{CC} = 5\text{V} \pm 10\%$, $V_{SS} = 0\text{V}$ unless otherwise noted)

Symbol	Parameter	Test conditions	Limits			Unit
			Min	Typ	Max	
V_{IH}	High-level input voltage		2.0		$V_{CC} + 0.3$	V
V_{IL}	Low-level input voltage		-0.3		0.8	V
V_{OH}	High-level output voltage	$I_{OH} = -400\mu\text{A}$	2.4			V
		$I_{OH} = -20\mu\text{A}$	4.4			V
V_{OL}	Low-level output voltage	$I_{OL} = 2\text{mA}$			0.45	V
I_I	Input leak current	$V_I = 0\text{V}$, V_{CC}	-10		10	μA
I_{OZ}	Output floating leak current	$V_O = 0\text{V} \sim V_{CC}$	-10		10	μA
C_I	Input terminal capacitance	$V_{IL} = 0\text{V}$, $f = 1\text{MHz}$, 25mVrms , $T_a = 25^\circ\text{C}$			10	pF
$C_{I/O}$	Input/output terminal capacitance	$V_{I/O} = 0\text{V}$, $f = 1\text{MHz}$, 25mVrms , $T_a = 25^\circ\text{C}$			20	pF
I_{CC}	Supply current from V_{CC} (operating)	$f = 5\text{MHz}$			10	mA
I_{CCS}	Supply current from V_{CC} (stand by)	$V_I = 0\text{V}$, V_{CC}			10	μA

Note 5 : Current flowing into an IC is positive, out is negative.

POWER DOWN ELECTRICAL CHARACTERISTICS ($T_a = -20 \sim 75^\circ\text{C}$, $V_{SS} = 0\text{V}$ unless otherwise noted)

Symbol	Parameter	Test conditions	Limits			Unit
			Min	Typ	Max	
$V_{CC(PD)}$	Power down supply voltage		2.0			V
$I_{CC(PD)}$	Power down supply current from V_{CC}	$V_{CC} = 2\text{V}$, other inputs = 0V			10	μA

TIMING REQUIREMENTS ($T_a = -20 \sim 75^\circ\text{C}$, $V_{CC} = 5\text{V} \pm 10\%$, $V_{SS} = 0\text{V}$ unless otherwise noted)

Symbol	Parameter	Test conditions	Limits			Unit
			Min	Typ	Max	
$t_{SU(A-L)}$	Address setup time before latch		30			ns
$t_{H(L-A)}$	Address hold time after latch		30			ns
$t_{d(L-RW)}$	Delay time, latch to read/write		40			ns
$t_{W(L)}$	Latch pulse width		70			ns
$t_{d(RW-L)}$	Delay time, read/write to latch		10			ns
$t_{W(RW)}$	Read/write pulse width		200			ns
$t_{SU(DQ-W)}$	Data setup time before write		100			ns
$t_{H(W-DQ)}$	Data hold time after write		0			ns
$t_{C(RW)}$	Read/write cycle time		200			ns
$t_{SU(P-R)}$	Port setup time before read		50			ns
$t_{H(R-P)}$	Port hold time after read		10			ns
$t_{W(STB)}$	Strobe pulse width		150			ns
$t_{SU(P-STB)}$	Port setup time before strobe		0			ns
$t_{H(STB-P)}$	Port hold time after strobe		100			ns
$t_{W(\#H)}$	Timer input high-level pulse width		70			ns
$t_{W(\#L)}$	Timer input low-level pulse width		40			ns
$t_{d(W-\#)}$	Delay time, write to timer input		200			ns
$t_{C(\#)}$	Timer input cycle time		200		DC	ns
$t_r(\#)$	Timer input rise time				100	ns
$t_f(\#)$	Timer input fall time				100	ns

CMOS 2048-BIT STATIC RAM WITH I/O PORTS AND TIMER

SWITCHING CHARACTERISTICS (Ta=-20~75°C, Vcc=5V±10%, Vss=0V unless otherwise noted)

Symbol	Parameter	Test conditions	Limits			Unit
			Min	Typ	Max	
t _{PZV(R-DQ)}	Propagation time from read to data output	C _L = 150pF			120	ns
t _{PZV(A-DQ)}	Propagation time from address to data output				330	ns
t _{PVZ(R-DQ)}	Propagation time from read to data floating (Note 6)		0		80	ns
t _{PHL(W-P)}	Propagation time from write to data output				300	ns
t _{PLH(W-P)}	Propagation time from write to data output				300	ns
t _{PLH(STB-BF)}	Propagation time from strobe to BF flag				300	ns
t _{PHL(R-BF)}	Propagation time from read to BF flag				300	ns
t _{PLH(STB-INTR)}	Propagation time from strobe to interrupt				300	ns
t _{PHL(R-INTR)}	Propagation time from read to interrupt				300	ns
t _{PLH(STB-BF)}	Propagation time from strobe to BF flag				300	ns
t _{PLH(W-BF)}	Propagation time from write to BF flag				300	ns
t _{PHL(W-INTR)}	Propagation time from write to interrupt				300	ns
t _{PHL(T-OUT)}	Propagation time from timer input to timer output				300	ns
t _{PLH(T-OUT)}	Propagation time from timer input to timer output				300	ns

Note 6 : Test conditions are not applied.

7 : A.C Testing waveform

Input pulse level 0.45~2.4V
 Input pulse rise time 10ns
 Input pulse fall time 10ns
 Reference level input V_{IH}=2V, V_{IL}=0.8V
 output V_{OH}=2V, V_{OL}=0.8V

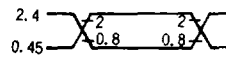

CMOS 2048-BIT STATIC RAM WITH I/O PORTS AND TIMER

TIMING DIAGRAM

Basic Output

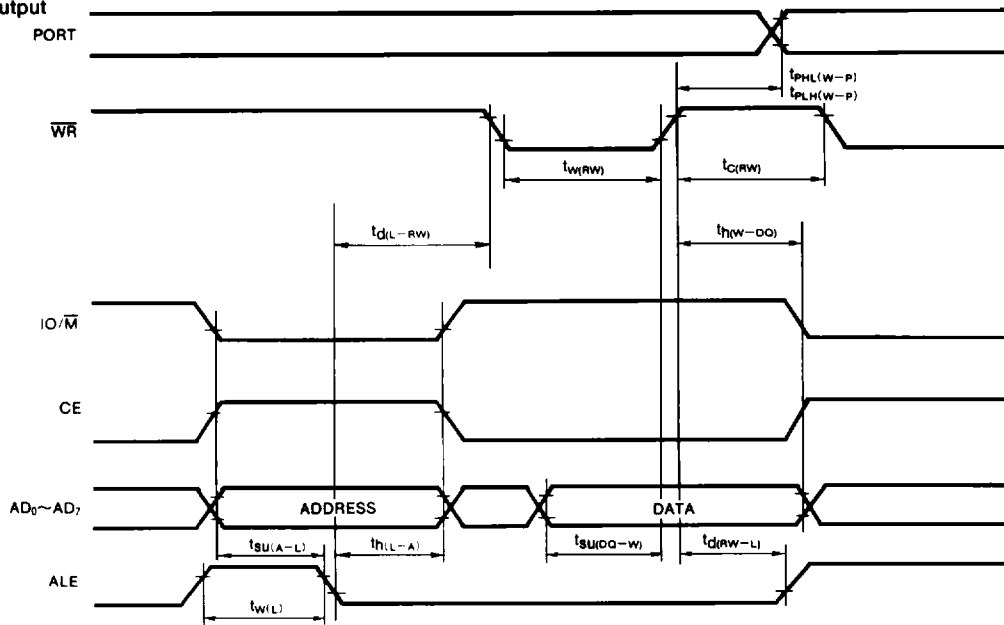

Basic Input

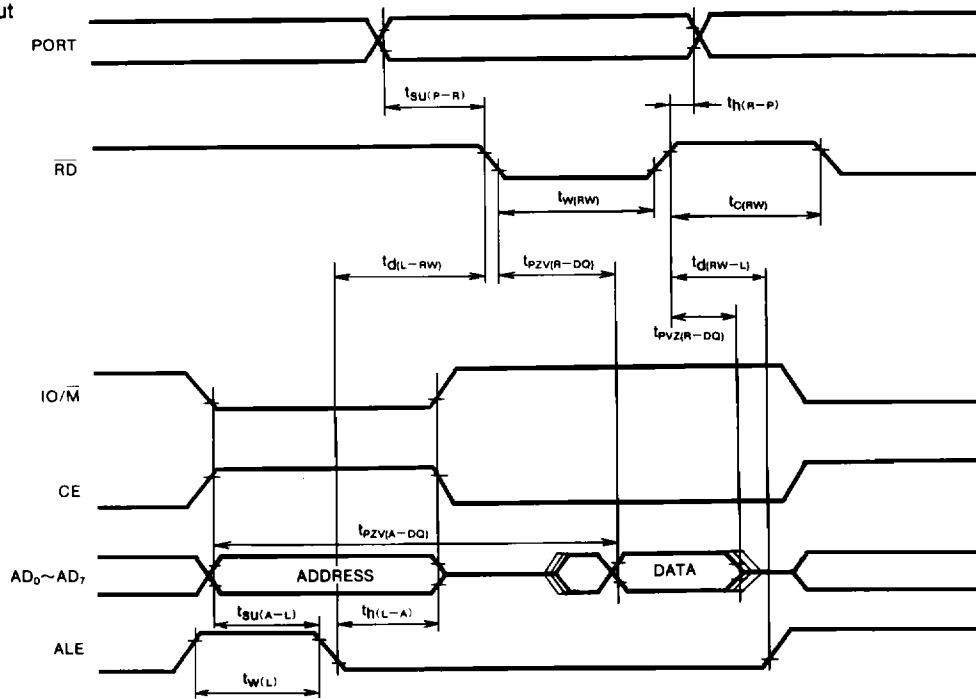

CMOS 2048-BIT STATIC RAM WITH I/O PORTS AND TIMER

Strobed output

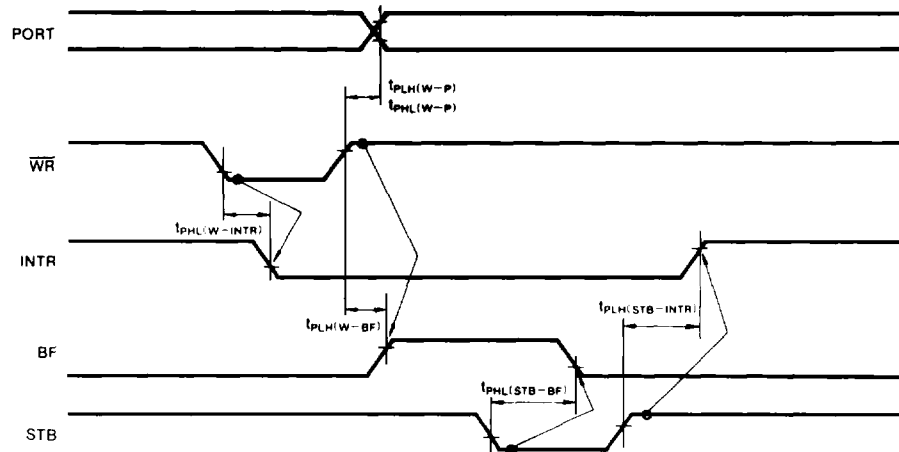

Strobed input

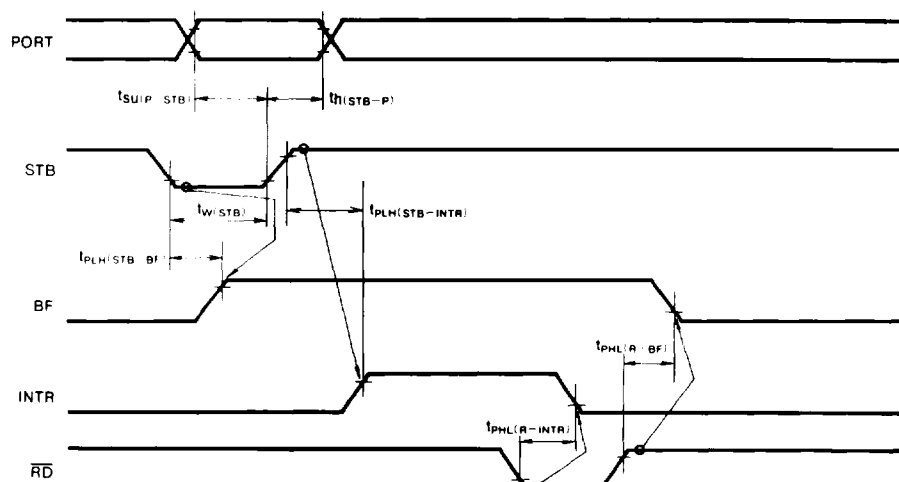

Timer

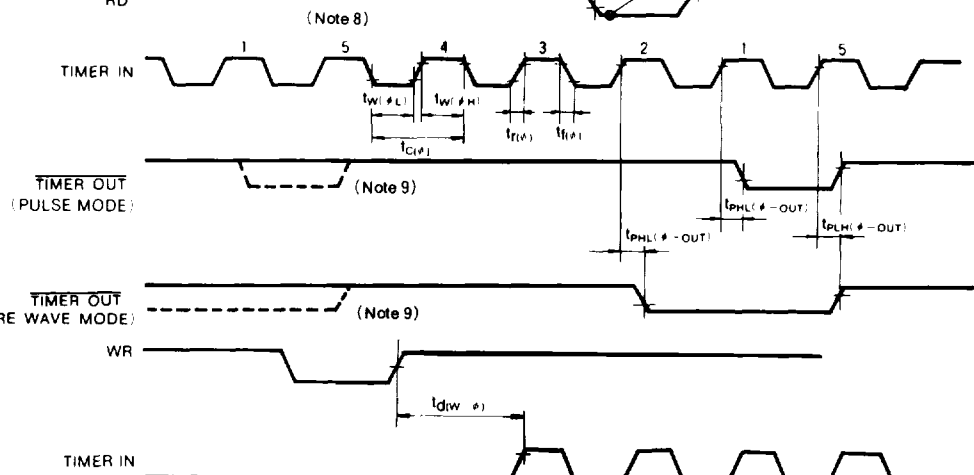

Note 8 : The wave form is shown for the case of counting down from 5 to 1.

9 : As long as the M1 mode flag of the timer register is at high-level, pulses are continuously output