

Fig. 6 Phase v. input

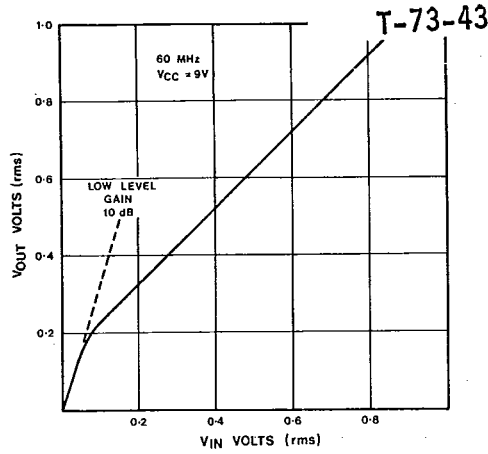

Fig. 7 Transfer characteristics linear plot

TYPICAL APPLICATION — 6 STAGE LOG STRIP

- Input log range 0dBm to -70dBm
- Low level gain 60dB (-70dBm in)
- Output dynamic range 20dB
- Phase shift (over log range) $\pm 3^\circ$
- Frequency range 10 — 200MHz

The circuit shown in Fig 9 is designed to illustrate the use of the SL531 in a complete strip. The supply voltage is fed to each stage via an external 180Ω resistor to allow operation to 125°C ambient. If the ambient can be limited to + 100°C then the internal resistor can be used to reduce the external component count. Interstage coupling is very simple with just a capacitor to isolate bias levels being necessary. No connection is necessary to pin 5 unless operation below 10MHz is required. It is important to provide extra decoupling on pin 1 of the first stage to prevent positive feedback occurring down the supply line. An SL560 is used as a unity gain buffer, the output of the log strip being attenuated before the SL560 to give a nominal 0dBm output into 50Ω.

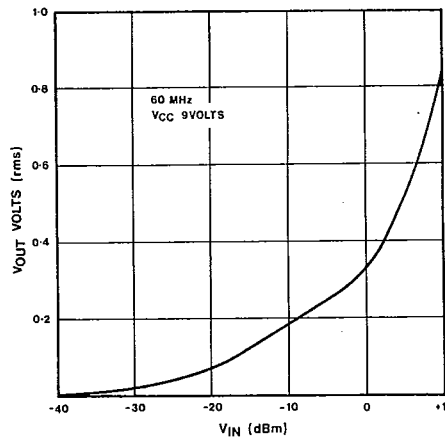

Fig. 8 Transfer characteristics logarithmic input scale

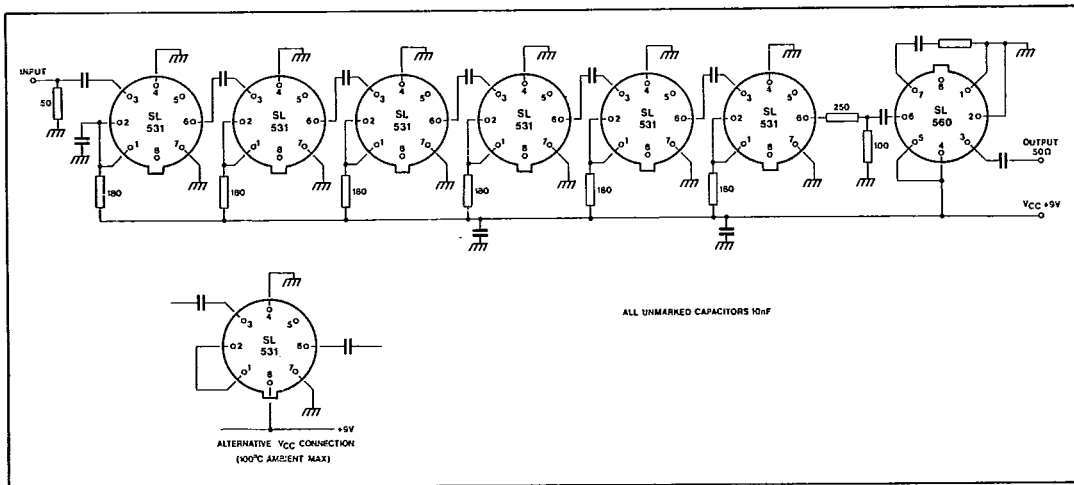

Fig. 9 Circuit diagram 6 stage strip



T-73-61

SL532C

LOW PHASE SHIFT LIMITER

The SL532C is a monolithic integrated circuit designed for use in wideband limiting IF strips. It offers a bandwidth of over 400MHz and very low phase shift with amplitude. The small signal gain is 12dB and the limited output is 1V peak to peak. The use of a 5GHz IC process has produced a circuit which gives less than 1° phase shift when overdriven by 12dB. The amplifier has internal decoupling capacitors to ease the construction of cascaded strips and the number of external components required has been minimised.

The device is also available as the SL532AC which has guaranteed operation over the full Military Temperature Range and is screened to MIL-STD-883C Class B. Data is available separately.

FEATURES

- Low Phase Shift v. Amplitude
- Wide Bandwidth
- Low External Component Count

APPLICATIONS

- Phase Recovery Strips in Radar and ECM Systems (e.g. Doppler)
- Limiting Amps for SAW Pulse Compression Systems
- Phase Monopulse Radars
- Phased Array Radars
- Low Noise Oscillators

ABSOLUTE MAXIMUM RATINGS

Supply voltage	+15V
Storage temperature range	-55°C to +150°C
Operating temperature range	-55°C to +125°C

CIRCUIT DESCRIPTION

The SL532 uses a long-tailed pair limiting amplifier which combines low phase shift with a symmetrical limiting characteristic. This is followed by a simple emitter follower output stage. Each stage of a strip is capable of driving to full output a succeeding SL532 but a buffer amplifier is needed to drive lower impedance loads. No external decoupling capacitors are normally required but for use below 10MHz extra decoupling can be added on pins 1 and 5. Bias for the long-tailed pair is provided by connecting the bias (pin 2) to the decoupled supply (pin 1).

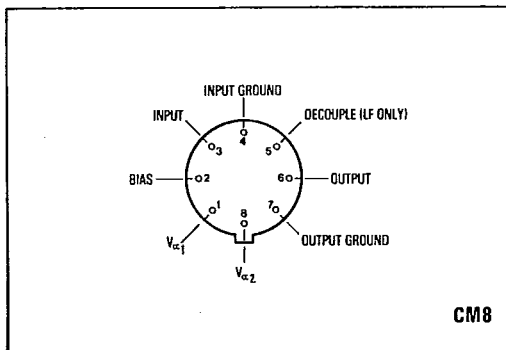

Fig.1 Pin connections

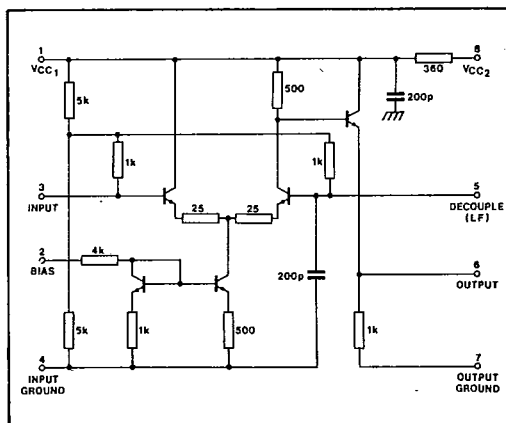

Fig.2 Circuit diagram

ELECTRICAL CHARACTERISTICS

Test conditions (unless otherwise stated):

Temperature (ambient) 25°C ± 2°C

Frequency 60MHz : R_L = 1kΩ / <5pF : V_{IN} = -30dBm

V_{CC} = +9.0V : R_S = 50Ω

T-73-61

Characteristic	Value			Units	Conditions
	Min.	Typ.	Max.		
Small signal voltage gain	11	12.8	14	dB	
Small signal voltage gain		12.5		dB	f = 150MHz
-1dB compression point		-10		dBm	
Limited output voltage	1.0	1.15	1.4	V p-p	V _{IN} = +10dBm
Limited output voltage		1.10		V p-p	f = 150MHz
Upper cut-off frequency	250			MHz	-3dB w.r.t. 60MHz
Lower cut-off frequency			10	MHz	May be extended by decoupling pin 5
Supply current	6	8.5	11	mA	No signal
Phase variation with signal level		±1	±3	Degrees	-30dBm to +10dBm
		±1.5		Degrees	-30dBm to 0dBm. f = 150MHz
Absolute phase shift input to output		-21		Degrees	f = 60MHz
		-34		Degrees	f = 100MHz
		-43		Degrees	f = 150MHz
		-69		Degrees	f = 200MHz
				Degrees	
Input impedance		1kΩ/2.5pF			
Output impedance		30Ω			
Noise figure		7		dB	400Ω source impedance. f = 60MHz
Gain variation with temperature		±2		dB	-40°C to 85°C
Phase variation with temperature		±0.5		Degrees	-40°C to +85°C at any level
				Degrees	between -30dBm to +10dBm
Limited output voltage variation with temperature		±0.05		V p-p	V _{IN} = +10dBm -40°C to +85°C

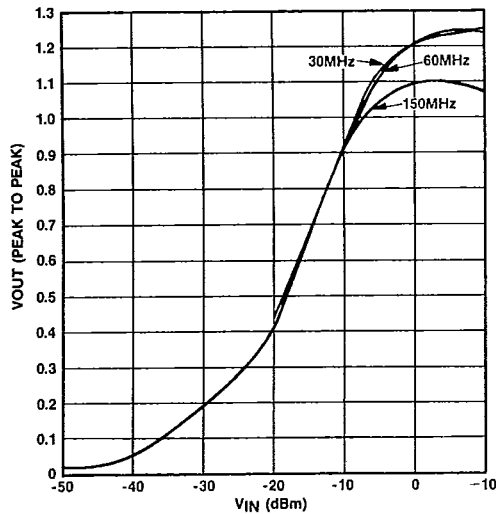

Fig.3 Transfer characteristic of a single stage

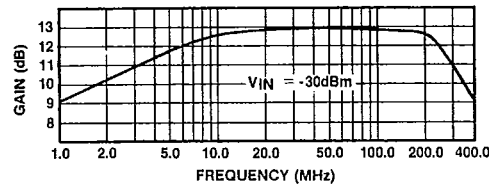

Fig.4 Gain/frequency curve of a typical device

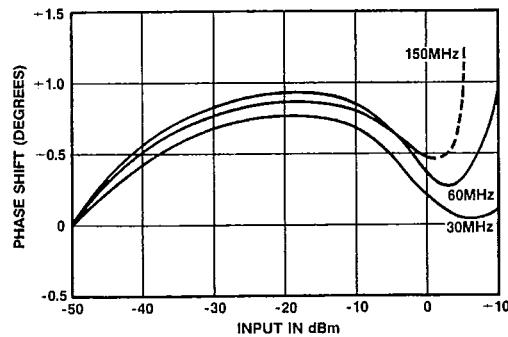

Fig.5 Phase change with input level

TYPICAL APPLICATION

Five stage strip

Input signal for full limiting 300 μ V rms
-57 dBm
Limited output 1V p-p
Phase shift ($V_{IN} - 57 \rightarrow +10$ dBm) $\pm 3^\circ$ typ.

T-73-61

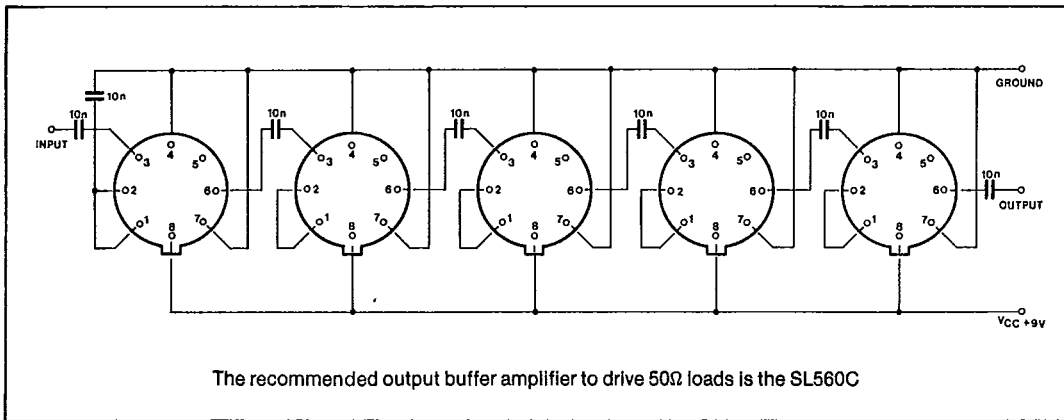

Fig.6 Five stage IF strip

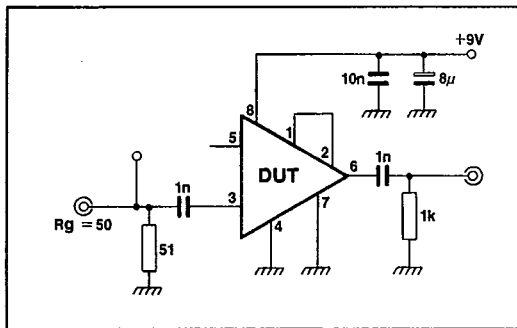

Fig.7 SL532 test circuit