

0.8mm Pitch, Compact and Robust Wire-to-Board Connectors

DF52 Series



■ Features

1. Small-sized connector

0.8mm Pitch, 1.75mm Height, 4.1mm Depth. Suitable for small-sized applications.

2. Small but robust structure

The housing is designed with thick walls while remaining small. This produces a strong, robust connector that resists damage.

3. Suitable for high current applications.

The maximum current of 2.5A (using 2-pos 28 AWG wire) is achieved by using highly conductive material and appropriate contact force.

4. BOX shaped contact prevents deformation.

The BOX shaped crimp contact prevents deformation during assembly and contributes to the overall stability and robustness.

5. Visual check insures fully mated Plug and Receptacle

The housing is designed with an open side that allows for visual inspection to insure the connectors are fully mated preventing accidental disconnect.

6. Glow Wire compliance (Compliant with IEC 60695-2-11)

7. Halogen-free

Chlorine and bromine levels are below standard values of IEC 61249-2-21.

Br : less than 900ppm, Cl : less than 900ppm,

Br + Cl : less than 1,500ppm.

◆ Small and robust structure

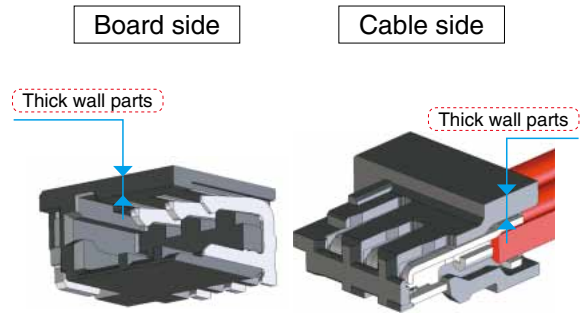

Housing walls are thick while the connector remains small.

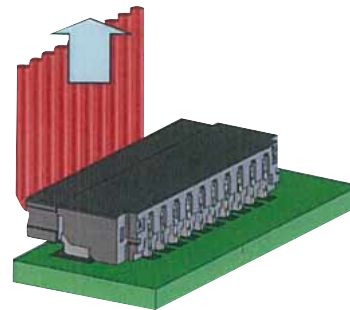

Robust structure prevents damage while routing wiring.

Fig.1

◆ Box shaped contact structure

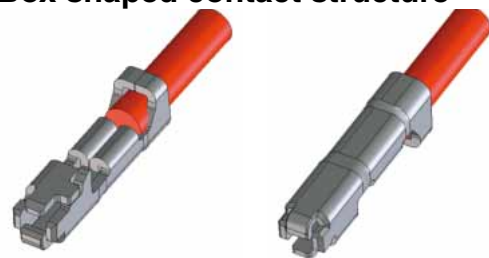

The Box shaped structure of the crimp contact prevents deformation.

Fig.2

◆ Allows for visual inspection of the mating process.

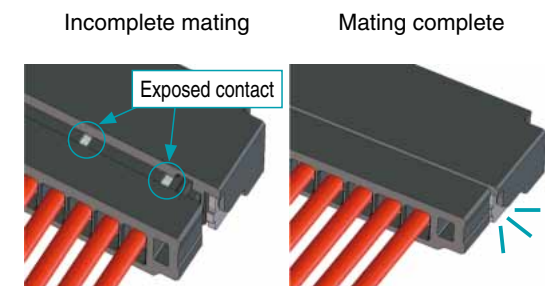

The contact is exposed in the half-mated state.

Mating is complete when the contact is no longer visible.

The mated condition can be visually checked.

Fig.3

Product Specifications

| | | | | | | | |
|----------------|----------------|-----------------|------|--------|---------|---|--|
| Ratings | Current Rating | No. of contacts | 2 | 3 to 5 | 6 to 10 | 12 or more | Operating temperature range : -40 to 85°C (Note 1) Operating humidity range : 20 to 80 % (Note 2) |
| | | 28 AWG | 2.5A | 2.0A | 1.5A | 1.2A | |
| | | 30 AWG | 2.0A | 1.5A | 1.2A | 1.0A | |
| | 32 AWG | 1.5A | 1.0A | 0.8A | 0.8A | | |
| Voltage Rating | AC/DC 100V | | | | | Storage temperature range : -10 to 60°C (Note 3) Storage humidity range : 40 to 70% (Note 3) | |

| Items | Specifications | Conditions |
|---------------------------|--|---|
| 1. Insulation resistance | 100MΩ min. | Measured at 100V DC |
| 2. Withstanding Voltage | No flashover dielectric breakdown | 300V AC applied for 1 minute. |
| 3. Contact resistance | 10mΩ max. | Measured at a maximum of 20 V DC, 1mA (DC or 1000Hz) |
| 4. Vibration resistance | No electrical discontinuity for more than 1μs | 10 cycles in each of three axis at frequency 10-55 Hz, half amplitude 0.75mm |
| 5. Shock resistance | No electrical discontinuity for more than 1μs | Acceleration of 490 m/s ² , 11 ms, 3 directions (semi-sinusoidal), 3 cycles each |
| 6. Moisture resistance | Contact resistance : 20mΩ max. insulation resistance : 100MΩ min. | Temperature : 40±2°C ; humidity : 90 to 95%, for 96 hours |
| 7. Temperature cycle | Contact resistance : 20mΩ max. insulation resistance : 100MΩ min. | (-55°C for 30 minutes 5 to 35°C for 2 to 3 minutes 85°C for 30 minutes 5 to 35°C for 2 to 3 minutes) in 5 cycles |
| 8. Mating durability | Contact resistance : 20mΩ max. | Mating and Unmating : 20 times |
| 9. Solder heat resistance | No dissolution of housing parts that affect performance. | Reflow : according to the Recommended Temperature Profile Manual soldering : temperature of soldering iron at 350°C ± 10°C for 3 seconds |

Note 1 : Includes the temperature rise caused by current flow.

Note 2 : Use in environments without condensation.

Note 3 : The term "storage" refers to the long-term storage condition of unused products before PCB mounting.

Operating temperature/humidity range is applied to the deenergized state after mounting of PCB and the temporary storage state during transportation.

Materials / Finish

| Product | Part | Materials | Finish | UL Regulation |
|---------------|-----------|--------------|-------------|---------------|
| Receptacle | Insulator | Polyamide | Black | UL94V-0 |
| | Contact | Copper alloy | Tin plating | — |
| Crimping plug | Insulator | Polyamide | Black | UL94V-0 |
| Crimp contact | Contact | Copper alloy | Tin plating | — |

Product Number Structure

Refer to the chart below when determining the product specifications from the product number.

Please select from the product numbers listed in this catalog when placing orders.

● Receptacle

DF 52 - * S - 0.8 H

① ② ③ ④ ⑤ ⑥

| | |
|----------------------|--|
| ① Series name | : DF |
| ② Series No. | : 52 |
| ③ Number of contacts | : 2, 3, 4, 5, 6, 8, 10, 12, 14, 15, 16, 17, 20 |
| ④ Connector type | S : Receptacle |
| ⑤ Contact Pitch | : 0.8mm |
| ⑥ Termination style | H : SMT Right Angle Type |

● Plug connector

DF 52 - * P - 0.8 C

① ② ③ ④ ⑤ ⑥

| | |
|----------------------|--|
| ① Series name | : DF |
| ② Series No. | : 52 |
| ③ Number of contacts | : 2, 3, 4, 5, 6, 8, 10, 12, 14, 15, 16, 17, 20 |
| ④ Connector type | P : Crimping plug |
| ⑤ Contact Pitch | : 0.8mm |
| ⑥ Termination style | C : Crimping plug |

● Crimp contact

DF 52 - 2832 PCF

① ② ③ ④

| | |
|----------------------------------|----------------------------|
| ① Series name | : DF |
| ② Series No. | : 52 |
| ③ Applicable wire size | : 2832 28 to 32 AWG |
| ④ Method type/Packaging type PCF | : Plug crimp contact, reel |

Right angle receptacle

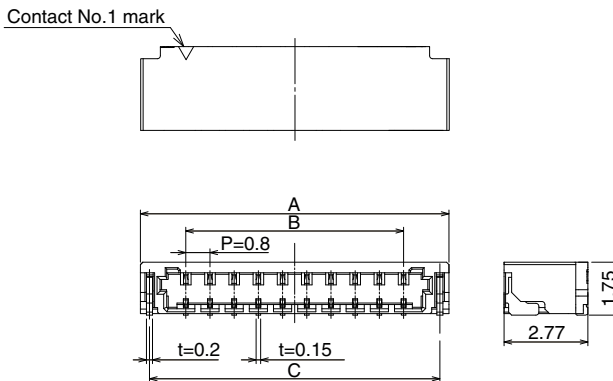

Unit : mm

| Part No. | HRS No. | No. of contacts | A | B | C |
|-------------------|---------------|-----------------|------|------|------|
| DF52-2S-0.8H(21) | 668-0004-5 21 | 2 | 3.8 | 0.8 | 3.2 |
| DF52-3S-0.8H(21) | 668-0022-7 21 | 3 | 4.6 | 1.6 | 4.0 |
| DF52-4S-0.8H(21) | 668-0005-8 21 | 4 | 5.4 | 2.4 | 4.8 |
| DF52-5S-0.8H(21) | 668-0023-0 21 | 5 | 6.2 | 3.2 | 5.6 |
| DF52-6S-0.8H(21) | 668-0006-0 21 | 6 | 7.0 | 4.0 | 6.4 |
| DF52-8S-0.8H(21) | 668-0007-3 21 | 8 | 8.6 | 5.6 | 8.0 |
| DF52-10S-0.8H(21) | 668-0008-6 21 | 10 | 10.2 | 7.2 | 9.6 |
| DF52-12S-0.8H(21) | 668-0009-9 21 | 12 | 11.8 | 8.8 | 11.2 |
| DF52-14S-0.8H(21) | 668-0024-2 21 | 14 | 13.4 | 10.4 | 12.8 |
| DF52-15S-0.8H(21) | 668-0010-8 21 | 15 | 14.2 | 11.2 | 13.6 |
| DF52-16S-0.8H(21) | 668-0025-5 21 | 16 | 15.0 | 12.0 | 14.4 |
| DF52-17S-0.8H(21) | 668-0001-7 21 | 17 | 15.8 | 12.8 | 15.2 |
| DF52-20S-0.8H(21) | 668-0011-0 21 | 20 | 18.2 | 15.2 | 17.6 |

Recommended PCB layout

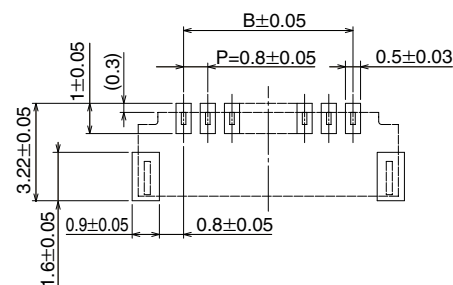

[Specification Number]
(21) : Tin plating, embossed packaging

Note : Please place orders for embossed packaged products in multiples 5,000 (5,000 pcs/reel).

Packaging Specification

●2 to 17 pos.

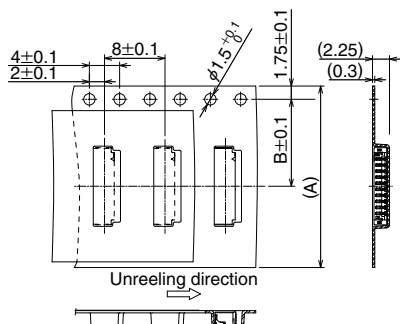

●20 pos.

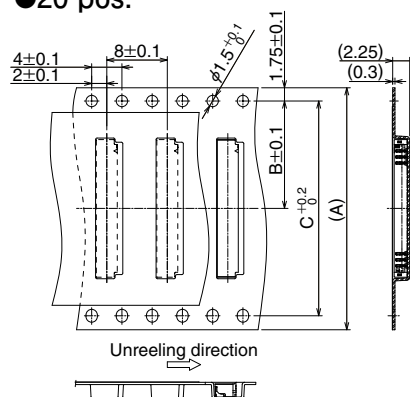

Unit : mm

| Part No. | No. of contacts | A | B | C | D | E |
|-------------------|-----------------|------|------|------|------|------|
| DF52-2S-0.8H(21) | 2 | 16.0 | 7.5 | - | 22.4 | 16.4 |
| DF52-3S-0.8H(21) | 3 | | | | | |
| DF52-4S-0.8H(21) | 4 | | | | | |
| DF52-5S-0.8H(21) | 5 | | | | | |
| DF52-6S-0.8H(21) | 6 | 24.0 | 11.5 | - | 30.4 | 24.4 |
| DF52-8S-0.8H(21) | 8 | | | | | |
| DF52-10S-0.8H(21) | 10 | | | | | |
| DF52-12S-0.8H(21) | 12 | | | | | |
| DF52-14S-0.8H(21) | 14 | 32.0 | 14.2 | 28.4 | 38.4 | 32.4 |
| DF52-15S-0.8H(21) | 15 | | | | | |
| DF52-16S-0.8H(21) | 16 | | | | | |
| DF52-17S-0.8H(21) | 17 | | | | | |
| DF52-20S-0.8H(21) | 20 | | | | | |

Style of reel

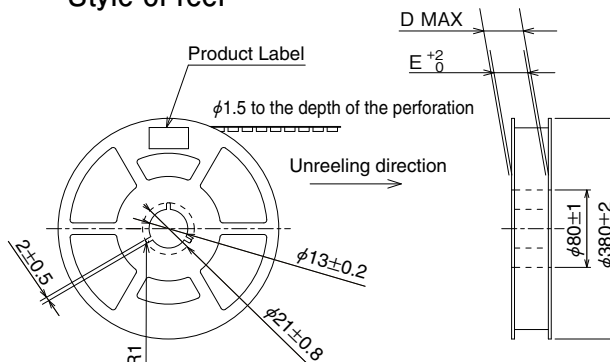

■ Crimping plug

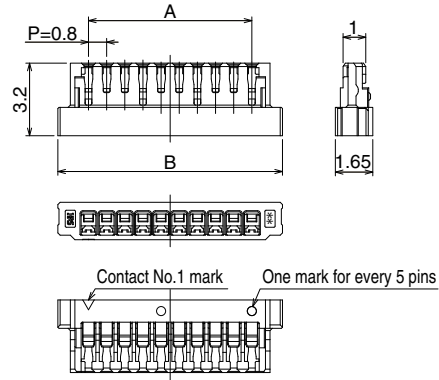

Unit : mm

| Part No. | HRS No. | No. of contacts | A | B |
|---------------|---------------|-----------------|------|------|
| DF52-2P-0.8C | 668-0013-6 00 | 2 | 0.8 | 3.5 |
| DF52-3P-0.8C | 668-0026-8 00 | 3 | 1.6 | 4.3 |
| DF52-4P-0.8C | 668-0014-9 00 | 4 | 2.4 | 5.1 |
| DF52-5P-0.8C | 668-0027-0 00 | 5 | 3.2 | 5.9 |
| DF52-6P-0.8C | 668-0015-1 00 | 6 | 4.0 | 6.7 |
| DF52-8P-0.8C | 668-0016-4 00 | 8 | 5.6 | 8.3 |
| DF52-10P-0.8C | 668-0017-7 00 | 10 | 7.2 | 9.9 |
| DF52-12P-0.8C | 668-0018-0 00 | 12 | 8.8 | 11.5 |
| DF52-14P-0.8C | 668-0028-3 00 | 14 | 10.4 | 13.1 |
| DF52-15P-0.8C | 668-0019-2 00 | 15 | 11.2 | 13.9 |
| DF52-16P-0.8C | 668-0029-6 00 | 16 | 12.0 | 14.7 |
| DF52-17P-0.8C | 668-0002-0 00 | 17 | 12.8 | 15.5 |
| DF52-20P-0.8C | 668-0020-1 00 | 20 | 15.2 | 17.9 |

[Specification Number]
None : 100 pcs/pack

Note : Please specify the number of packs (100 pcs/pack) when placing orders.

■ Crimp contact

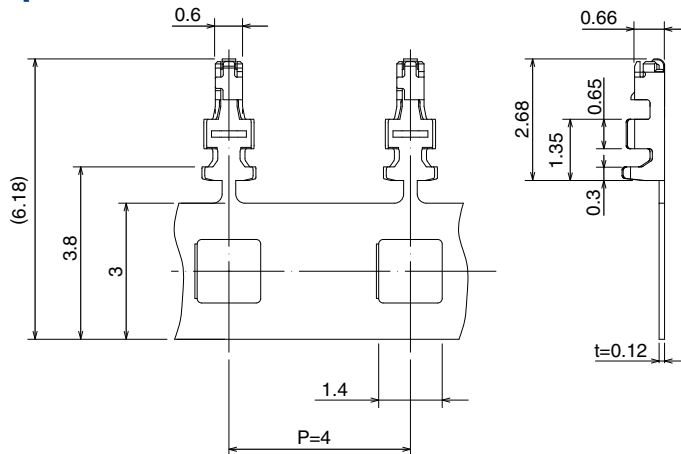

[Specification Number]
None : 40,000 pcs/reel

| Part No. | HRS No. | Type | Quantity | Finish |
|--------------|---------------|--------------|-----------------|-------------|
| DF52-2832PCF | 668-0030-5 00 | Reel contact | 40,000 pcs/reel | Tin plating |

Note 1 : This product is sold in 40,000 pieces per reels. Please place orders in multiples of 40,000.

● Applicable wire (Tinned Annealed Copper Wire)

| Conductor size (Core structure) | Jacket outer diameter | Recommended wire | Strip length |
|---------------------------------------|-----------------------|--------------------|--------------|
| 28 AWG (7 pieces/0.127mm in diameter) | φ0.5 to 0.6mm | UL1571 (thin line) | 0.9 to 1.3mm |
| 30 AWG (7 pieces/0.102mm in diameter) | | | |
| 32 AWG (7 pieces/0.08mm in diameter) | | | |

Note : Please contact our Sales representative when using wires other than applicable wires.

Note : The strip length is a reference value. Please adjust the strip length accordingly for specifications and requirements.
Refer to the crimping quality standard (ATAD-H0789) for details.

◆Applicable crimping tools

| Type | Part No. | HRS No. | Applicable contact | Remarks |
|---------------|------------------|---------------|--------------------|---|
| Applicator | AP105-DF52-2832P | 901-4636-7 | DF52-2832PCF | |
| | DHS877900H-UP | — | DF52-2832PCF | (Note 2) Manufactured by Japan Automatic Machine Co.,Ltd. |
| Press body | CM-105C | 901-0001-0 00 | — | |
| Pull-out tool | DF-C-PO(B) | 550-0179-2 00 | DF52-2832PCF | |

Note 1 : Issues caused by using other than our specified tools are not covered by warranty.

Note 2 : Applicator manufactured by JAPAN AUTOMATIC MACHINE (J.A.M.). Please access to HP of J.A.M., if you make inquiries about the applicator or crimp defect. (URL : <http://www.jam-net.co.jp>)

◆Precautions

| | |
|---|---|
| <p>1. Recommended Temperature Profile (Compatible with lead-free soldering)</p> | <p>[Applicable Conditions]</p> <ol style="list-style-type: none"> 1. Peak temperature : 250°C max. 2. Heating area : 220°C min. for less than 60 seconds 3. Preheating area : 150°C to 180°C for 90 to 120 seconds 4. Number of times : no more than 2 times <p>* Measurement is conducted at the contact lead part Soldering results may change depending on conditions such as solder paste type, manufacturer, PCB size, and other soldering materials. Please determine all mounting conditions before use. Note 1 : This temperature profile is a recommended value.</p> |
| <p>2. Recommended manual soldering conditions</p> | <p>Temperature of soldering iron : 350±10°C, soldering time : within 3 seconds</p> |
| <p>3. Recommended screen thickness and aperture ratio (Pattern surface ratio)</p> | <p>Thickness : 0.1mm, aperture opening ratio : 100%</p> |
| <p>4. Warpage of the Board</p> | <p>A maximum of 0.02mm at the center of connector, as measured from either end of the connector</p> |
| <p>5. Cleaning Conditions</p> | <p>IPA cleaning is allowed. (Cleaning is not recommended due to potential changes in mating action and other variables. Please contact us if you use other cleaning agents.)</p> |
| <p>6. Noteworthy Points</p> | <ul style="list-style-type: none"> ■ Please note that any mating operation of the connector when not mounted on the board may cause damage or deformation of the contacts. ■ During hand soldering, do not apply flux, as it will flow over the connector. ■ This housing color may have slight variations depending on the production lot. This color variation does not affect performance. ■ Please refer to "DF52 mating and unmating Procedure Document (ETAD-H0788)" for points in handling regarding mating operations. ■ Please refer to "Harness procedure manual (ETAD-H0791)" for points in harness operations. |

USA:

HIROSE ELECTRIC (U.S.A.), INC. HEADQUARTERS CHICAGO OFFICE
2300 Warrenville Road, Suite 150,
Downers Grove, IL 60515
Phone : +1-630-282-6700
<http://www.hirose.com/us/>

USA:

HIROSE ELECTRIC (U.S.A.), INC. SAN JOSE OFFICE
2841 Junction Ave, Suite 200
San Jose, CA. 95134
Phone : +1-408-253-9640
Fax : +1-408-253-9641
<http://www.hirose.com/us/>

USA:

HIROSE ELECTRIC (U.S.A.), INC. DETROIT OFFICE (AUTOMOTIVE)
17197 N. Laurel Park Drive, Suite 253,
Livonia, MI 48152
Phone : +1-734-542-9963
Fax : +1-734-542-9964
<http://www.hirose.com/us/>

THE NETHERLANDS:

HIROSE ELECTRIC EUROPE B.V.
Hogehillweg #8 1101 CC Amsterdam Z-O
Phone : +31-20-6557460
Fax : +31-20-6557469
<http://www.hirose.com/eu/>

GERMANY:

HIROSE ELECTRIC EUROPE B.V. GERMAN BRANCH
Schoenbergstr. 20, 73760 ostfildern
Phone : +49-711-456002-1
Fax : +49-711-456002-299
<http://www.hirose.com/eu/>

GERMANY:

HIROSE ELECTRIC EUROPE B.V. NUREMBERG OFFICE
Neumeyerstrasse 22-26, 90411 Nurnberg
Phone : +49-911 32 68 89 63
Fax : +49-911 32 68 89 69
<http://www.hirose.com/eu/>

GERMANY:

HIROSE ELECTRIC EUROPE B.V. HANOVER OFFICE
Bayernstr. 3, Haus C 30855 Langenhagen, Germany
Phone : +49-511 97 82 61 30
Fax : +49-511 97 82 61 35
<http://www.hirose.com/eu/>

FRANCE:

HIROSE ELECTRIC EUROPE B.V. PARIS OFFICE
Regus La Garenne Colombes, Place de La Belgique,
71 Boulevard National La Garenne Colombes, 92250, France
Phone : +33 (0) 1 7082 3170
Fax : +33 (1) 7082 3101
<http://www.hirose.com/eu/>

UNITED KINGDOM:

HIROSE ELECTRIC EUROPE BV (UK BRANCH)
4 Newton Court, Kelvin Drive, Knowlhill,
Milton Keynes, MK5 8NH
Phone : +44-1908 202050
Fax : +44-1908 202058
<http://www.hirose.com/eu/>

CHINA:

HIROSE ELECTRIC (SHANGHAI) CO., LTD.
1601, Henderson Metropolitan, NO.300, East Nanjing
Road, Huangpu District, Shanghai, China 200001
Phone : +86-21-6391-3355
Fax : +86-21-6391-3335
<http://www.hirose.com/cn/>

CHINA:

HIROSE ELECTRIC (SHANGHAI) CO., LTD. BEIJING BRANCH
A1001, Ocean International Center, Building 56# East 4th
Ring Middle Road, ChaoYang District, Beijing, 100025
Phone : +86-10-5165-9332
Fax : +86-10-5908-1381
<http://www.hirose.com/cn/>

CHINA:

HIROSE ELECTRIC TECHNOLOGIES (SHENZHEN) CO., LTD.
Room 09-13, 19/F, Office Tower Shun Hing Square, Di Wang Commercial Centre,
5002 Shen Nan Dong Road, Shenzhen City, Guangdong Province, 518008
Phone : +86-755-8207-0851
Fax : +86-755-8207-0873
<http://www.hirose.com/cn/>

HONG KONG:

HIROSE ELECTRIC HONGKONG TRADING CO., LTD.
Room 1001, West Wing, Tsim Sha Tsui Centre, 66
Mody Road, Tsim Sha Tsui East, Kowloon, Hong Kong
Phone : +852-2803-5338
Fax : +852-2591-6560
<http://www.hirose.com/hk/>

TAIWAN:

HIROSE ELECTRIC TAIWAN CO., LTD.
103 8F, No.87, Zhengzhou Rd., Taipei
Phone : +886-2-2555-7377
Fax : +886-2-2555-7350
<http://www.hirose.com/tw/>

KOREA:

HIROSE KOREA CO., LTD.
250, Huimanggongwon-ro, Siheung-si,
Gyeonggi-do, Korea, 15083
Phone : +82-31-496-7000 or 7124
Fax : +82-31-496-7100
<http://www.hirose.co.kr/>

SINGAPORE:

HIROSE ELECTRIC SINGAPORE PTE. LTD.
10 Anson Road #26-16, International Plaza
079903, Singapore
Phone : +65-6324-6113
Fax : +65-6324-6123
<http://www.hirose.com/sg/>

INDIA:

HIROSE ELECTRIC SINGAPORE PTE. LTD. DELHI LIAISON OFFICE
Office NO.552, Regus-Green Boulevard, Level5, Tower C,
Sec62, Plot B-9A, Block B, Noida, 201301, Uttar Pradesh, India
Phone : +91-12-660-8018
Fax : +91-120-4804949
<http://www.hirose.com/sg/>

INDIA:

HIROSE ELECTRIC SINGAPORE PTE. LTD. BANGALORE LIAISON OFFICE
Unit No-403, 4th Floor, No-84, Barton Centre, Mahatma
Gandhi (MG) Road, Bangalore 560 001, Karnataka, India
Phone : +91-80-4120 1907
Fax : +91-80-4120 9908
<http://www.hirose.com/sg/>

MALAYSIA:

PENANG REPRESENTATIVE OFFICE
1-21-01, Suntech @ Penang Cybercity (1164), Lintang
Mayang Pasir 3,11950, Bayan Baru, Penang, Malaysia.
Phone : +604-619-2564
Fax : +604-619-2574
<http://www.hirose.com/sg/>

THAILAND:

BANGKOK OFFICE (REPRESENTATIVE OFFICE)
Unit 4703, 47th FL., 1 Empire Tower, South Sathorn
Road, Yannawa, Sathorn, Bangkok 10120 Thailand
Phone : +66-2-686-1255
Fax : +66-2-686-3433
<http://www.hirose.com/sg/>

**HIROSE ELECTRIC CO., LTD.**

2-6-3, Nakagawa Chuoh, Tsuzuki-Ku, Yokohama-Shi 224-8540, JAPAN
TEL: +81-45-620-3526 Fax: +81-45-591-3726
<http://www.hirose.com>
<http://www.hirose-connectors.com>