

## SiGe - Low-Noise Amplifier (1900 MHz)



### Description

The TST0951 is a low-noise amplifier (LNA) in SiGe technology. This LNA offers the possibility to apply a gain switching through a control input pin, and provides a power-down mode function for extending the battery operation time.

In low-gain mode, the output drive capability is not reduced, resulting in improved intermodulation performance. The nominal gain is very precise and has max.  $\pm 1.0$  dB gain variation over full temperature range and supply-voltage range.

Electrostatic sensitive device.  
Observe precautions for handling.



### Features

- Input frequency 1800 to 2000 MHz
- Low noise figure at high gain mode ( $< 3$  dB)
- Precise gain (19 dB,  $\pm 1.0$  dB)
- Low- / high gain mode
- High gain flatness ( $\pm 0.3$  dB max.)
- Power-down function
- High reverse isolation (min. -40 dB)
- Small package (TSSO8)

### Block Diagram

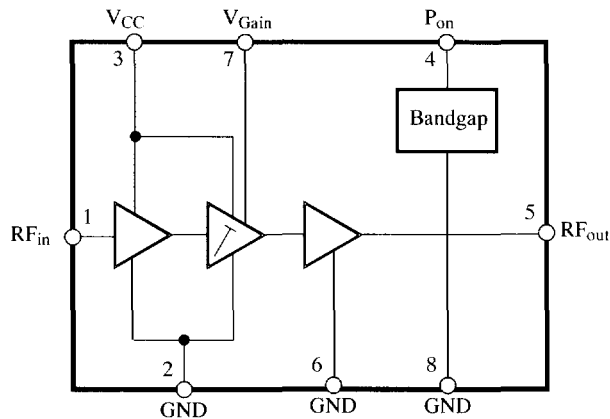

Figure 1. Block diagram

### Ordering Information

Extended Type Number	Package	Remarks
TST0951-MFDG3	TSSO8	Taped and reeled

## Pin Description

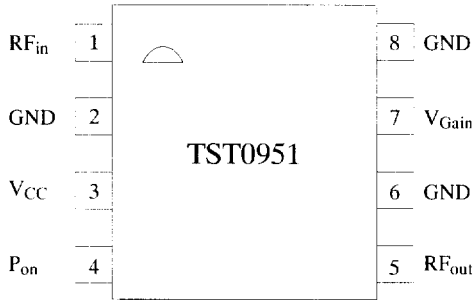

Figure 2. Pinning

Pin	Symbol	Function
1	RF <sub>in</sub>	RF input
2	GND	Ground
3	V <sub>CC</sub>	Supply voltage
4	P <sub>on</sub>	Power-down input
5	RF <sub>out</sub>	RF output
6	GND	Ground
7	V <sub>Gain</sub>	Gain switching input
8	GND	Ground

## Functional Description

The TST0951 is a very precise amplifier, especially designed for DCS/ PCS telephone applications. The circuit consists of three stages. By attenuating the output signal of the first stage, the complete amplifier gain is reduced and the intermodulation behavior is improved.

## Absolute Maximum Ratings

All voltages are referred to GND (Pins 2, 6 and 8)

Parameters	Symbol	Min.	Max.	Unit
Supply voltage Pin 3	V <sub>CC</sub>	2.7	3.3	V
Junction temperature	T <sub>j</sub>	-40	+125	°C
Storage temperature	T <sub>stg</sub>	-40	+150	°C
Input power Pin 1	RF <sub>in</sub>	-	-10	dBm
Power-down input Pin 4	P <sub>on</sub>	0	V <sub>CC</sub>	V
Gain switching input Pin 7	V <sub>Gain</sub>	0	V <sub>CC</sub>	V

## Solder Reflow Profile (SMD Packages)

Parameters	Symbol	Value	Unit
Maximum heating rate	T <sub>D</sub>	1 to 3	°C/s
Peak temperature in preheat zone	T <sub>PH</sub>	100 to 140	°C
Duration of time above melting point of solder	t <sub>MP</sub>	Min. 10 / Max. 130	s
Peak reflow temperature	T <sub>Peak</sub>	220 to 225	°C
Maximum cooling rate	T <sub>Peak</sub>	2 to 4	°C/s

## Wave Soldering (Through-Hole Packages)

Parameters	Symbol	Value	Unit
Maximum lead temperature (5 s)	T <sub>D</sub>	260	°C

## Operation Range

All voltages are referred to GND (Pins 2, 6 and 8)

Parameters	Symbol	Min.	Typ.	Max.	Unit
Supply voltage	$V_{CC}$	2.7	2.8	2.9	V
Ambient temperature	$T_{amb}$	-20		+70	°C
Input frequency	$RF_{in}$	1800		2000	MHz

**Note for biasing:** Apply first  $V_{CC}$ , then  $P_{on}$  and  $V_{Gain}$  (see absolute maximum ratings)

## Electrical Characteristics

Test conditions:  $V_{CC} = +2.8$  V,  $T_{amb} = +25$ °C, unless otherwise specified

Parameters	Test Conditions / Pins	Symbol	Min.	Typ.	Max.	Unit
<b>Power supply</b>						
Supply voltage	Pin 3	$V_{CC}$	2.7	2.8	2.9	V
Current consumption active mode		$I_a$		10	12	mA
power-down mode		$I_{pd}$		50	200	μA
<b>RF input / output</b>						
Input impedance *)	Pin 1	$Z_i$		50		Ω
Output impedance *)	Pin 5	$Z_o$		50		Ω
Frequency band		$F_{in}$	1800		2000	MHz
Nominal gain	Pin 1 to 5	G	18	19	20	dB
Gain attenuation related to nominal gain	Pin 1 to 5	$\Delta G$	17	18	19	dB
Gain flatness	Pin 1 to 5		-0.3		+0.3	dB
Noise figure in low-gain mode	Pin 1 to 5	NF		9	20	dB
in high-gain mode		NF			3.0	dB
Input VSWR *) in low-gain mode	LNA active Pin 1	VSWR			2:1	
in high-gain mode		VSWR			2:1	
Output VSWR *)	LNA active PON = '1' Pin 5	VSWR			2:1	
	LNA inactive PON = '0' Pin 5	VSWR			3:1	
Input 1 dB compression point in low-gain mode	Pin 1 to 5		-16			dBm
in high-gain mode			-21			dBm
Input intercept point 3rd order in low-gain mode	Pin 1 to 5		-7			dBm
in high-gain mode			-12			dBm
Reverse isolation in low-gain mode	Pin 5 to 1		40			dB
in high-gain mode			40			dB

\*) with external matching (see application circuit)

## Electrical Characteristics (continued)

Test conditions:  $V_{CC} = +2.8\text{ V}$ ,  $T_{amb} = +25^{\circ}\text{C}$ , unless otherwise specified

Parameters	Test Conditions / Pins	Symbol	Min.	Typ.	Max.	Unit
<b>Control function</b>						
Control inputs threshold high level low level	Pins 4 and 7	$V_{TH}$	$0.97 \times V_{CC}$		$0.03 \times V_{CC}$	V
		$V_{TH}$				V
Leakage current on control inputs low level	Pins 4 and 7	$I_l$			100	$\mu\text{A}$

<sup>\*)</sup> with external matching (see application circuit)

### Power-Down Logic

Level	$P_{on}$	Power Status
	'0'	Power OFF
	'1'	Power ON

### Gain Control Logic

Gain Level	$V_{Gain}$	Gain
	'0'	Minimum gain
	'1'	Maximum gain

**Test Circuit**

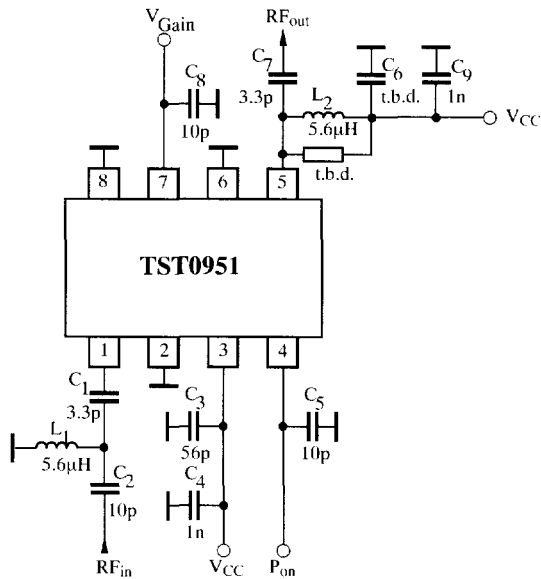

Figure 3. Test circuit

**Package Information**

Package TSS08  
Dimensions in mm

