

MCX3100-9179

MCX Plug Crimp Right Angle 75Ω

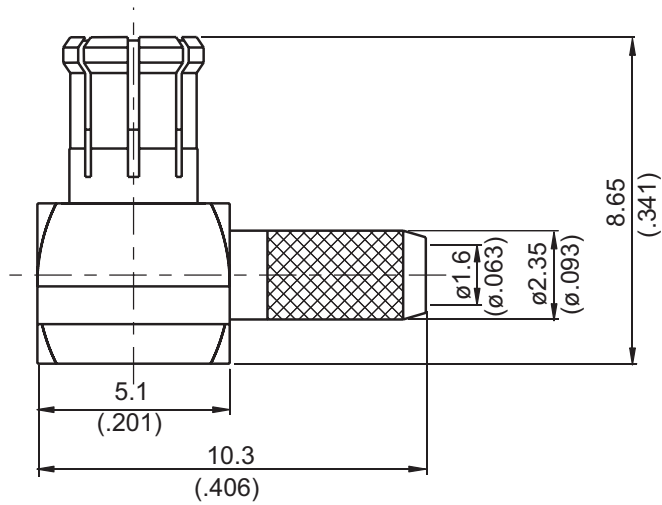

Parts	Material	Plating (Micro-inch)
Ferrule	Brass	Gold 5 Over Nickel 50 Over Copper 50
Cover	Brass	Gold 5 Over Nickel 50 Over Copper 50
Contact Pin	Brass	Gold 20 Over Nickel 50 Over Copper 50
Insulator	Teflon	
Body	Phosphor Bronze	Gold 5 Over Nickel 50 Over Copper 50

Weight: 1.14 g

Suitable Cables: RG179, RG179-FEP

Notice: JYEBAO reserves the right to make modifications deemed appropriate.

CABLE ASSEMBLY INSTRUCTION

MCX3100-9179

JYE BAO CO., LTD.

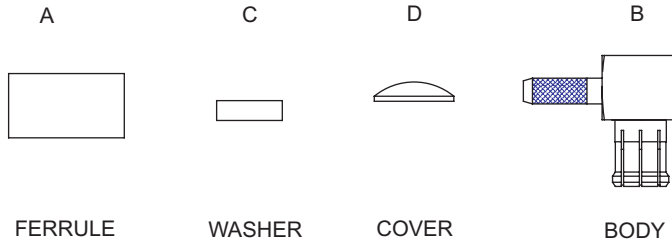

DIAGRAM	ASSEMBLY INSTRUCTION
	<p>Step 1: STRIP AS SHOWN.</p>
	<p>Step 2: SLIDE FERRULE "A" OVER CABLE. Step 3: WRAP THE BRAIDING UPWARDS. Step 4: SLIDE CENTER CONDUCTOR ON THE CONTACT PIN OF CONNECTOR "B" AND SOLDER IN "Y".</p>
	<p>Step 5: SLIDE FERRULE "A" TOWARDS THE CONNECTOR "B" AND CRIMP.</p>
	<p>Step 6: PRESS ON THE TOP OF "C" "D" WITH JIGS.</p>

Notice: JYEBAO reserves the right to make modifications deemed appropriate.