

F100158

8-Bit Shift Matrix

General Description

The F100158 contains a combinatorial network which performs the function of an 8-bit shift matrix. Three control lines (S_n) are internally decoded and define the number of places which an 8-bit word present at the inputs (D_n) is shifted to the left and presented at the outputs (Z_n). A Mode Control input (M) is provided which, if LOW, forces LOW all out-

puts to the right of the one that contains D_7 . This operation is sometimes referred to as *LOW backfill*. If M is HIGH, an end-around shift is performed such that D_0 appears at the output to the right of the one that contains D_7 . This operation is commonly referred to as *barrel shifting*. All inputs have 50 k Ω pull-down resistors.

Ordering Code: See Section 8

Logic Symbol

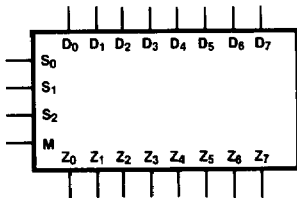

TL/F/9862-3

Pin Names	Description
D_0-D_7	Data Inputs
S_0-S_2	Select Inputs
M	Mode Control Input
Z_0-Z_7	Data Outputs

Connection Diagrams

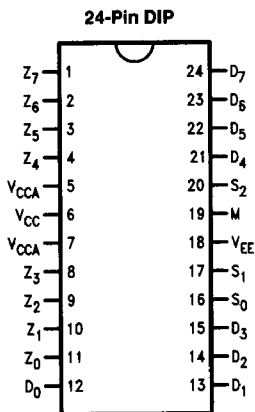

TL/F/9862-1

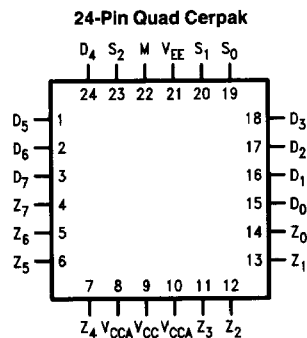

TL/F/1862-2

Logic Diagram

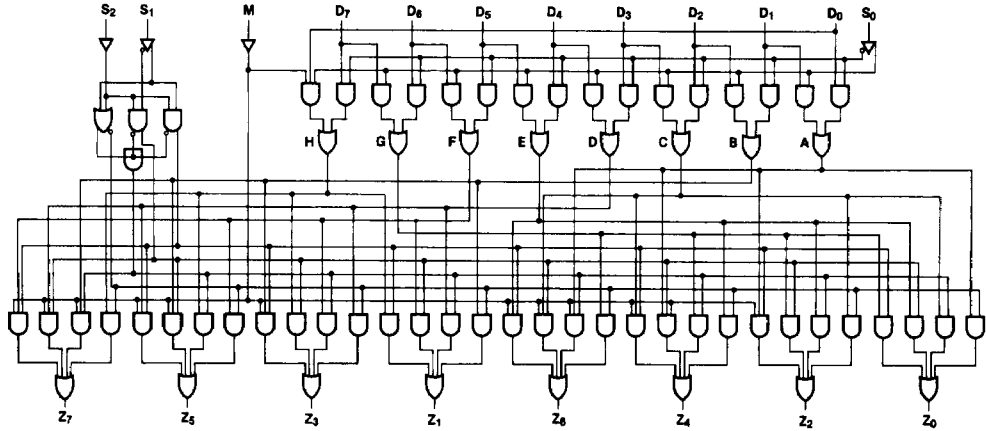

TL/F/9862-5

Truth Table

Inputs				Outputs							
M	S ₀	S ₁	S ₂	Z ₀	Z ₁	Z ₂	Z ₃	Z ₄	Z ₅	Z ₆	Z ₇
X	L	L	L	D ₀	D ₁	D ₂	D ₃	D ₄	D ₅	D ₆	D ₇
L	H	L	L	D ₁	D ₂	D ₃	D ₄	D ₅	D ₆	D ₇	L
L	L	H	L	D ₂	D ₃	D ₄	D ₅	D ₆	D ₇	L	L
L	H	H	L	D ₃	D ₄	D ₅	D ₆	D ₇	L	L	L
L	L	L	H	D ₄	D ₅	D ₆	D ₇	L	L	L	L
L	H	L	H	D ₅	D ₆	D ₇	L	L	L	L	L
L	L	H	H	D ₆	D ₇	L	L	L	L	L	L
L	H	H	H	D ₇	L	L	L	L	L	L	L
H	H	L	L	D ₁	D ₂	D ₃	D ₄	D ₅	D ₆	D ₇	D ₀
H	L	H	L	D ₂	D ₃	D ₄	D ₅	D ₆	D ₇	D ₀	D ₁
H	H	H	L	D ₃	D ₄	D ₅	D ₆	D ₇	D ₀	D ₁	D ₂
H	L	L	H	D ₄	D ₅	D ₆	D ₇	D ₀	D ₁	D ₂	D ₃
H	H	L	H	D ₅	D ₆	D ₇	D ₀	D ₁	D ₂	D ₃	D ₄
H	L	H	H	D ₆	D ₇	D ₀	D ₁	D ₂	D ₃	D ₄	D ₅
H	H	H	H	D ₇	D ₀	D ₁	D ₂	D ₃	D ₄	D ₅	D ₆

H = HIGH Voltage Level
 L = LOW Voltage Level
 X = Don't Care

Absolute Maximum Ratings

Above which the useful life may be impaired. (Note 1)

If Military/Aerospace specified devices are required, please contact the National Semiconductor Sales Office/Distributors for availability and specifications.

Storage Temperature - 65°C to + 150°C
Maximum Junction Temperature (T_J) + 150°C

Case Temperature under Bias (T_C) 0°C to + 85°C
V_{EE} Pin Potential to Ground Pin - 7.0V to + 0.5V
Input Voltage (DC) V_{EE} to + 0.5V
Output Current (DC Output HIGH) - 50 mA
Operating Range (Note 2) - 5.7V to - 4.2V

DC Electrical Characteristics

V_{EE} = -4.5V, V_{CC} = V_{CCA} = GND, T_C = 0°C to + 85°C (Note 3)

Symbol	Parameter	Min	Typ	Max	Units	Conditions (Note 4)	
V _{OH}	Output HIGH Voltage	-1025	-955	-880	mV	V _{IN} = V _{IH} (Max) or V _{IL} (Min)	Loading with 50Ω to -2.0V
V _{OL}	Output LOW Voltage	-1810	-1705	-1620			
V _{OHC}	Output HIGH Voltage	-1035			mV	V _{IN} = V _{IH} (Min) or V _{IL} (Max)	Loading with 50Ω to -2.0V
V _{OLC}	Output LOW Voltage			-1610			
V _{IH}	Input HIGH Voltage	-1165		-880	mV	Guaranteed HIGH Signal for All Inputs	
V _{IL}	Input LOW Voltage	-1810		-1475	mV	Guaranteed LOW Signal for All Inputs	
I _{IL}	Input LOW Current	0.50			μA	V _{IN} = V _{IL} (Min)	

DC Electrical Characteristics

V_{EE} = -4.2V, V_{CC} = V_{CCA} = GND, T_C = 0°C to + 85°C (Note 3)

Symbol	Parameter	Min	Typ	Max	Units	Conditions (Note 4)	
V _{OH}	Output HIGH Voltage	-1020		-870	mV	V _{IN} = V _{IH} (Max) or V _{IL} (Min)	Loading with 50Ω to -2.0V
V _{OL}	Output LOW Voltage	-1810		-1605			
V _{OHC}	Output HIGH Voltage	-1030			mV	V _{IN} = V _{IH} (Min) or V _{IL} (Max)	Loading with 50Ω to -2.0V
V _{OLC}	Output LOW Voltage			-1595			
V _{IH}	Input HIGH Voltage	-1150		-870	mV	Guaranteed HIGH Signal for All Inputs	
V _{IL}	Input LOW Voltage	-1810		-1475	mV	Guaranteed LOW Signal for All Inputs	
I _{IL}	Input LOW Current	0.50			μA	V _{IN} = V _{IL} (Min)	

DC Electrical Characteristics

V_{EE} = -4.8V, V_{CC} = V_{CCA} = GND, T_C = 0°C to + 85°C (Note 3)

Symbol	Parameter	Min	Typ	Max	Units	Conditions (Note 4)	
V _{OH}	Output HIGH Voltage	-1035		-880	mV	V _{IN} = V _{IH} (Max) or V _{IL} (Min)	Loading with 50Ω to -2.0V
V _{OL}	Output LOW Voltage	-1830		-1620			
V _{OHC}	Output HIGH Voltage	-1045			mV	V _{IN} = V _{IH} (Min) or V _{IL} (Max)	Loading with 50Ω to -2.0V
V _{OLC}	Output LOW Voltage			-1610			
V _{IH}	Input HIGH Voltage	-1165		-880	mV	Guaranteed HIGH Signal for All Inputs	
V _{IL}	Input LOW Voltage	-1830		-1490	mV	Guaranteed LOW Signal for All Inputs	
I _{IL}	Input LOW Current	0.50			μA	V _{IN} = V _{IL} (Min)	

Note 1: Absolute maximum ratings are those values beyond which the device may be damaged or have its useful life impaired. Functional operation under these conditions is not implied.

Note 2: Parametric values specified at -4.2V to -4.8V.

Note 3: The specified limits represent the "worst case" value for the parameter. Since these "worst case" values normally occur at the temperature extremes, additional noise immunity and guard banding can be achieved by decreasing the allowable system operating ranges.

Note 4: Conditions for testing shown in the tables are chosen to guarantee operation under "worst case" conditions.

DC Electrical Characteristics
 $V_{EE} = -4.2V$ to $-4.8V$ unless otherwise specified, $V_{CC} = V_{CCA} = GND$, $T_C = 0^\circ C$ to $+85^\circ C$

Symbol	Parameter	Min	Typ	Max	Units	Conditions
I_{IH}	Input HIGH Current All Inputs			220	μA	$V_{IN} = V_{IH} (Max)$
I_{EE}	Power Supply Current	-205	-140	-95	mA	Inputs Open

Ceramic Dual-In-Line Package AC Electrical Characteristics
 $V_{EE} = -4.2V$ to $-4.8V$, $V_{CC} = V_{CCA} = GND$

Symbol	Parameter	$T_C = 0^\circ C$		$T_C = +25^\circ C$		$T_C = +85^\circ C$		Units	Conditions
		Min	Max	Min	Max	Min	Max		
t_{PLH} t_{PHL}	Propagation Delay D_n to Output	1.10	2.80	1.10	2.70	1.10	2.80	ns	<i>Figures 1 and 2</i>
t_{PLH} t_{PHL}	Propagation Delay M to Output	1.15	4.20	1.25	4.20	1.15	4.20	ns	
t_{PLH} t_{PHL}	Propagation Delay S_n to Output	1.70	4.20	1.70	4.20	1.70	4.20	ns	
t_{TLH} t_{THL}	Transition Time 20% to 80%, 80% to 20%	0.50	2.30	0.50	2.30	0.50	2.30	ns	

Cerpak AC Electrical Characteristics
 $V_{EE} = -4.2V$ to $-4.8V$, $V_{CC} = V_{CCA} = GND$

Symbol	Parameter	$T_C = 0^\circ C$		$T_C = +25^\circ C$		$T_C = +85^\circ C$		Units	Conditions
		Min	Max	Min	Max	Min	Max		
t_{PLH} t_{PHL}	Propagation Delay D_n to Output	1.10	2.60	1.10	2.50	1.10	2.60	ns	<i>Figures 1 and 2</i>
t_{PLH} t_{PHL}	Propagation Delay M to Output	1.15	4.00	1.25	4.00	1.15	4.00	ns	
t_{PLH} t_{PHL}	Propagation Delay S_n to Output	1.70	4.00	1.70	4.00	1.70	4.00	ns	
t_{TLH} t_{THL}	Transition Time 20% to 80%, 80% to 20%	0.50	2.20	0.50	2.20	0.50	2.20	ns	

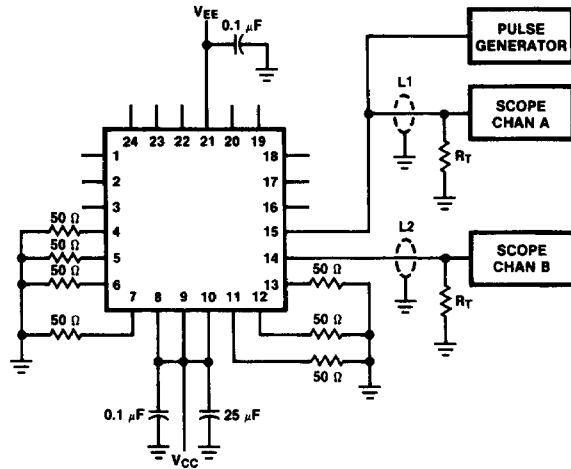

TL/F/9862-6

Notes:

- $V_{CC}, V_{CCA} = +2V, V_{EE} = -2.5V.$
- $L1$ and $L2$ = equal length 50Ω impedance lines.
- $R_T = 50\Omega$ terminator internal to scope.
- Decoupling $0.1 \mu F$ from GND to V_{CC} and V_{EE} .
- All unused outputs are loaded with 50Ω to GND.
- C_L = fixture and stray capacitance $\leq 3 pF.$
- Pin numbers shown are for flatpak; for DIP refer to logic symbol.

FIGURE 1. AC Test Circuit

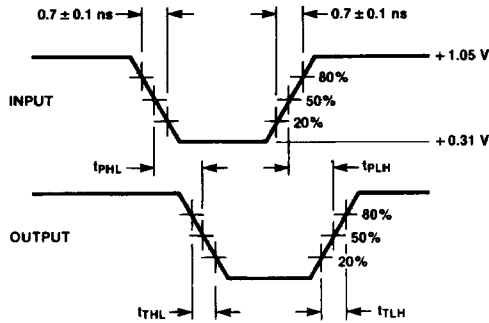

TL/F/9862-7

FIGURE 2. Propagation Delay and Transition Times

Applications

The following technique uses two ranks of F100158s to shift a 64-bit word from 0 to 63 places. Although two stage delays are required (one for each rank), the total shift takes only about 4 ns. This technique performs a bit shift on each 8-bit byte in the first rank and then a modulo-8 byte shift on the 64-bit word in the second rank.

Basic 16-Bit 0-7 Place Shifter

Figure 3 shows the basic 0-7 place shift technique which can be expanded to accommodate any word length.

Each 8-bit byte requires a pair of F100158s operating in the LOW backfill mode. The address lines for each pair of ICs are driven out of phase by three OR gates. Inputs for the two ICs are taken from two bytes transposed in order; outputs are transposed and emitter-OR tied. One device shifts right from location 0 and the other shifts left from location 7. The bits shifted off one pair are picked up by the next pair of F100158s or—in the case of the last one in the rank—returned to the first device. The net result is a 0-7 place shift of the entire word.

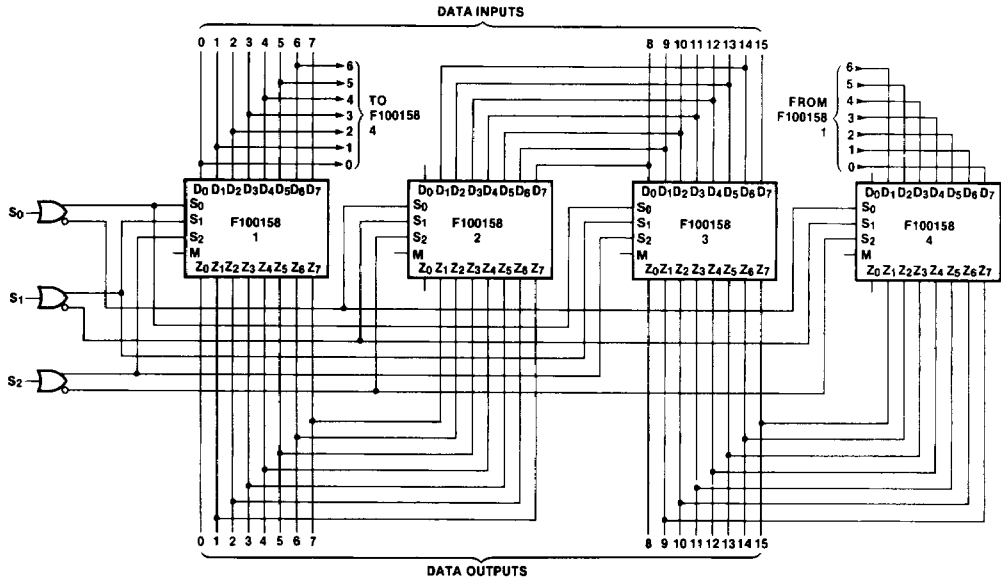

FIGURE 3. Basic 16-Bit 0-7 Place Shifter

TL/F/9862-8

Applications (Continued)

Expanding to 64-Bit Word and 64-Place Shift

The basic 0-7 place shift technique can be expanded to accommodate a 64-bit word shifted from 0 to 63 places, however, two ranks of F100158s are required (Figure 4). The first rank is identical to the one illustrated in Figure 3 except it contains a total of 16 devices. The second rank consists of eight additional F100158s connected in the modulo-8 configuration shown in Figure 5.

The modulo-8 rank is used to simulate an 8-bit simultaneous shift since the F100158 cannot shift in 8-bit jumps. The modulo-8 configuration is achieved by wiring the first rank and the output device to the second rank as illustrated in Figure 5. The LSB of each output byte in the first rank is wired to one of the eight inputs of the first F100158 in the

second rank. The next least significant bit of each first-rank F100158 pair, however, is connected to the inputs of the second F100158 in the second rank. The other first-ranked outputs are connected in a similar fashion to the remainder of the second-rank inputs. Ultimately, the outputs of the second rank must then be connected to reform the final usable 64-bit word so that the bits are again ordered from 0-63.

The effect is that each single-location shift in the second rank appears to be an eight place shift in the final word due to the way the inputs and outputs of the second rank are connected. The combination of the two ranks produces the 64-place shift of the entire word.

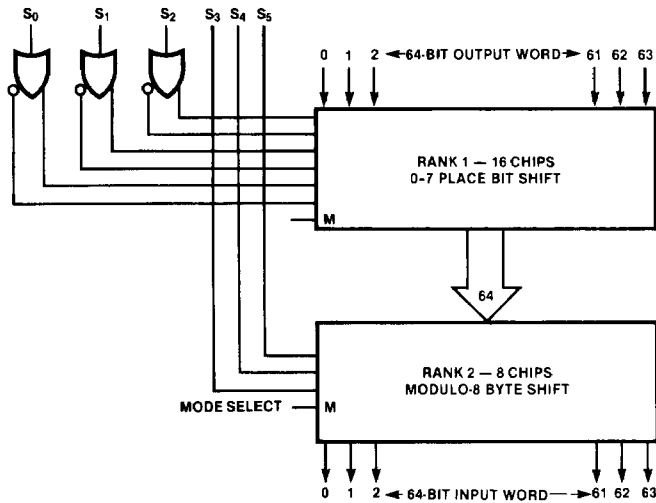

FIGURE 4. 64-Bit 0-63 Place Barrel Shifter

TL/F/9862-9

Applications (Continued)

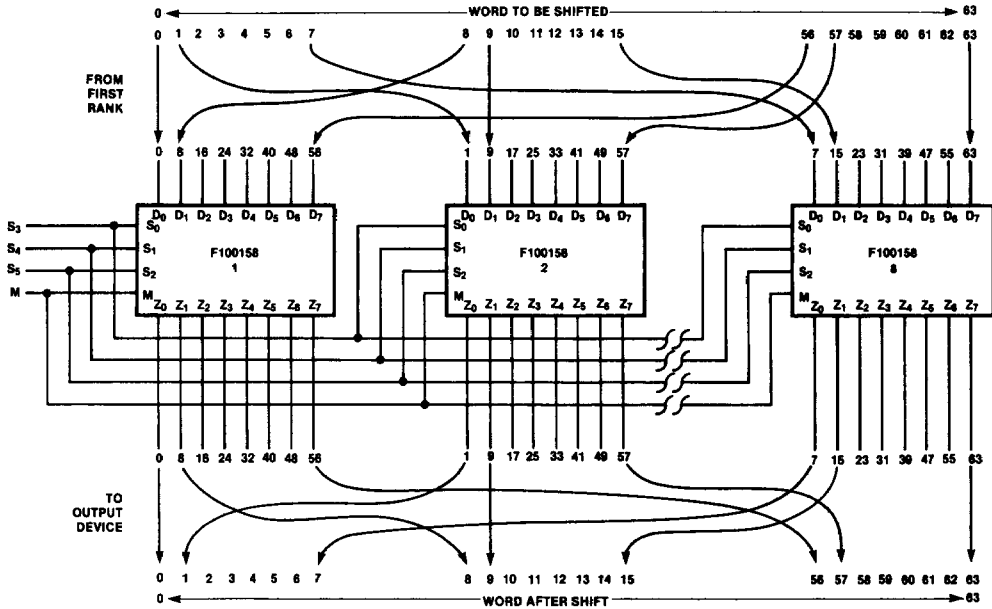

FIGURE 5. Modulo-8 Shift

TL/F/9862-10