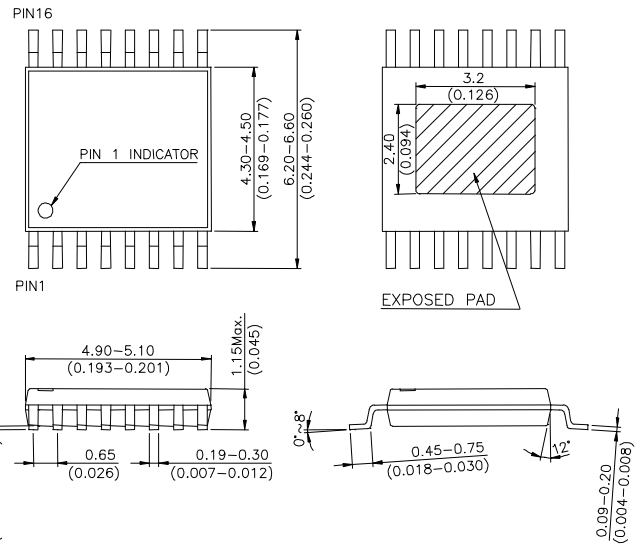

**Features**

- Four Inputs, Two Outputs switch
- Insertion Loss: 5.5 dB
- Isolation: 30.5 dB
- Low DC Power Consumption
- Small TSSOP16 Plastic Package
- PHEMT process

**TSSOP-16**

**Description**

The HWS388 is a GaAs PHEMT 4x2 switch operating at 0.95 to 2.15 GHz in a low cost TSSOP16 plastic package. Any of the four inputs can be directed to any of the two outputs. The HWS388 is suitable for use in Direct Broadcast Satellite (DBS) switching system applications.

**Electrical Specifications at 25 °C with 0V/+5V Control Voltages and 0 dBm Pin**

Parameter	Test Conditions	Min.	Typ.	Max.	Unit
Insertion Loss	0.95-2.15 GHz		5.5	7.0	dB
Insertion Loss Flatness	0.95-2.15 GHz		1.0		dB
Isolation	0.95-1.50 GHz	30.5	33.5		dB
	1.50-2.15 GHz	27.5	30.5		dB
Output Return Loss	0.95-2.15 GHz		15		dB
Control Current	Per control pin			500	uA

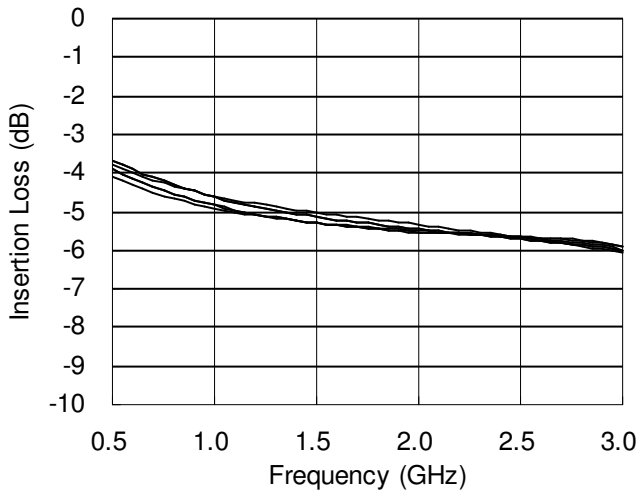
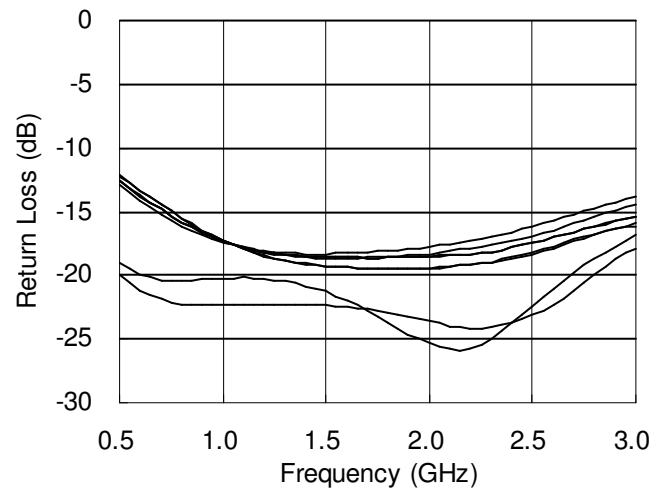
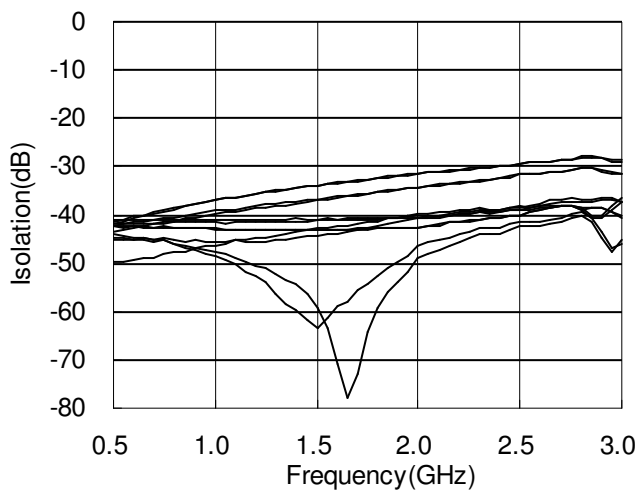
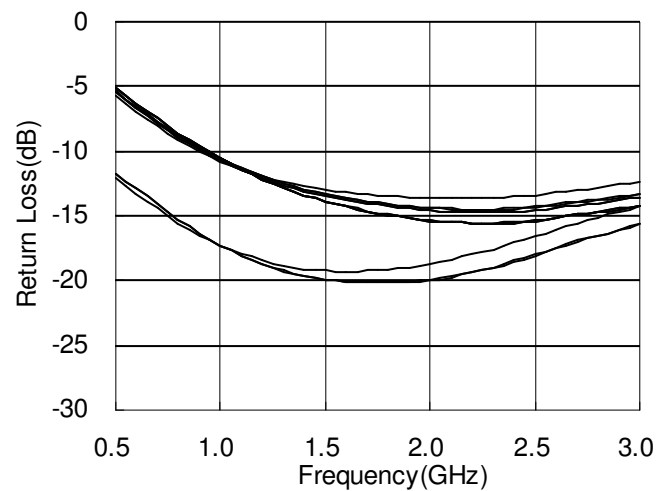
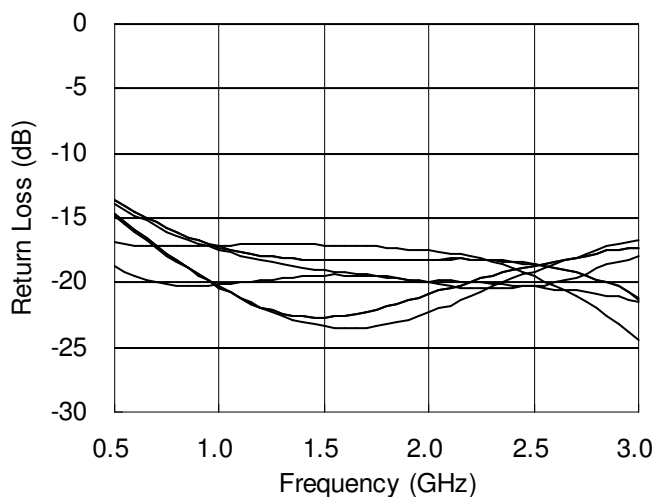
Note: All measurements made in a 50 ohm system with 0/+5.0V control voltages, unless otherwise specified.

**Typical Performance Data of Various States @ +25 °C**
**Insertion Loss vs Frequency**

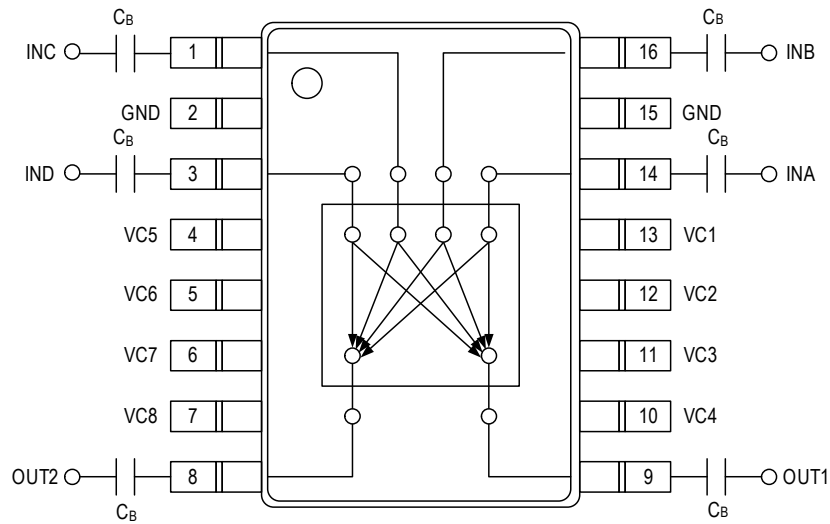
**Input Return Loss(On-Path) vs Frequency**

**Isolation vs Frequency**

**Input Return Loss(Off-Path) vs Frequency**

**Output Return Loss vs Frequency**

**Pin Out (Top View)**

**Note:**

1. DC blocking capacitors  $C_B=51\text{pF}$  are required on all RF ports.
2. Exposed pad in the bottom must be connected to ground by via holes.

**Logic Table for Switch On-Path**

On Path		Control Pins							
OUT1	OUT2	VC1	VC2	VC3	VC4	VC5	VC6	VC7	VC8
INA	-	1	0	1	0	-	-	-	-
INB	-	1	0	0	1	-	-	-	-
INC	-	0	1	1	0	-	-	-	-
IND	-	0	1	0	1	-	-	-	-
-	INA	-	-	-	-	1	0	1	0
-	INB	-	-	-	-	1	0	0	1
-	INC	-	-	-	-	0	1	1	0
-	IND	-	-	-	-	0	1	0	1

'1' = +5V

'0' = 0V

**Absolute Maximum Ratings**

Parameter	Absolute Maximum
RF Input Power	+15 dBm @ +6V
Control Voltage	+6V
Operating Temperature	-40 °C to +85 °C
Storage Temperature	-65 °C to +150 °C