

MN65543S

Low Power 8-Bit CMOS A/D Converter for Image Processing

■ Overview

The MN65543S is an 8-bit CMOS analog-to-digital converter with a maximum conversion rate of 15 MSPS.

It uses a half flash structure based on chopper comparators and achieves both high speed and low power consumption with multiplex processing.

■ Features

- Maximum conversion rate: 15 MSPS (min.)
- Linearity error: ± 0.5 LSB (typ.)
- Differential linearity error: ± 0.3 LSB (typ.)
- Power supply voltage: 4.40 to 5.25 V
- Power consumption: 90 mW (typ.)

■ Applications

- Digital television receivers
- Digital video equipment
- Digital image processing equipment

■ Pin Assignment

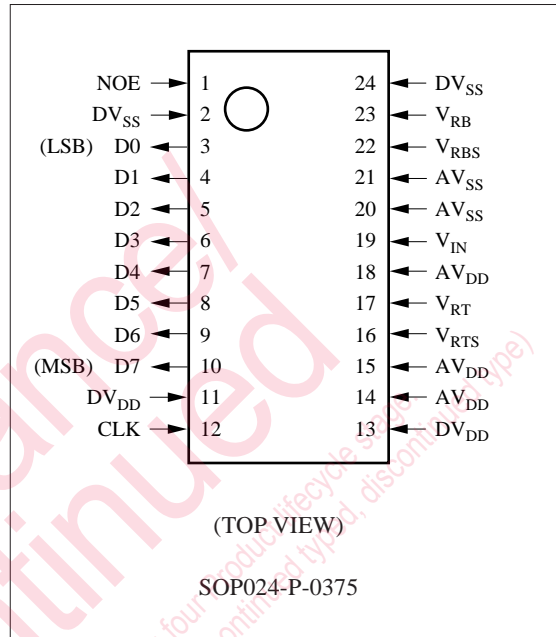

■ Block Diagram

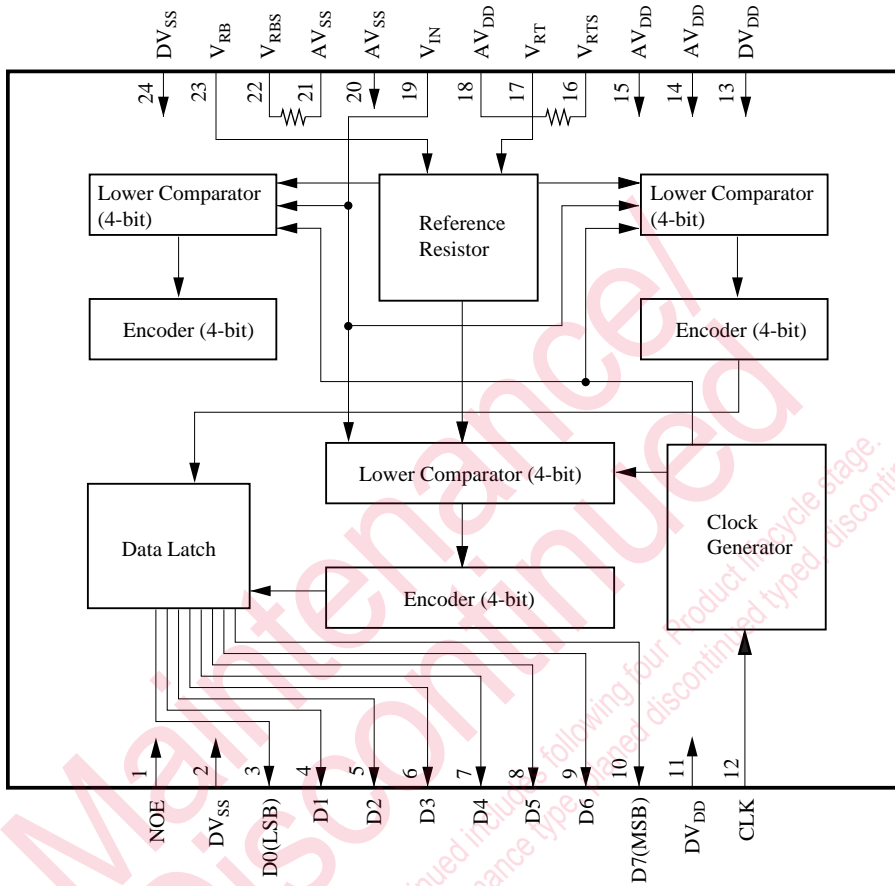

■ Pin Descriptions

Pin No.	Symbol	Function Description
1	NOE	Output enable
2	DV _{SS}	Ground for digital circuits
3	D0	Digital output (LSB)
4	D1	Digital output
5	D2	Digital output
6	D3	Digital output
7	D4	Digital output
8	D5	Digital output
9	D6	Digital output
10	D7	Digital output (MSB)
11	DV _{DD}	Power supply for digital circuits
12	CLK	Sampling clock
13	DV _{DD}	Power supply for digital circuits
14	AV _{DD}	Power supply for analog circuits
15	AV _{DD}	Power supply for analog circuits
16	V _{RTS}	Power supply for reference voltage (TOP)
17	V _{RT}	Reference voltage (TOP)
18	AV _{DD}	Power supply for analog circuits
19	V _{IN}	Analog input
20	AV _{SS}	Ground for analog circuits
21	AV _{SS}	Ground for analog circuits
22	V _{RBS}	Power supply for reference voltage (BOTTOM)
23	V _{RB}	Reference voltage (BOTTOM)
24	DV _{SS}	Ground for digital circuits

■ Absolute Maximum Ratings $T_a=25^\circ\text{C}$

Parameter	Symbol	Rating	Unit
Power supply voltage	V _{DD}	- 0.3 to +7.0	V
Input voltage	V _I	AV _{SS} - 0.3 to AV _{DD} +0.3	V
Output voltage	V _O	DV _{SS} - 0.3 to DV _{DD} +0.3	V
Operating ambient temperature	T _{opr}	-20 to +70	°C
Storage temperature	T _{stg}	-55 to +125	°C

Recommended Operating Conditions $V_{DD}=AV_{DD}=DV_{DD}=5.0V$, $V_{SS}=AV_{SS}=DV_{SS}=0V$, $T_a=25^\circ C$

Parameter	Symbol	min	typ	max	Unit
Power supply voltage	V_{DD}	4.50	5.00	5.25	V
Digital input voltage	"H" level	V_{IH}	2.4	V_{DD}	V
	"L" level	V_{IL}	V_{SS}	0.8	V
Reference voltage	"H" level	V_{RT}	3.5	V_{DD}	V
	"L" level	V_{RB}	V_{SS}	1.5	V
Clock	"H" level pulse width	t_{WH}	30		ns
	"L" level pulse width	t_{WL}	30		ns
Analog input voltage	V_{AIN}	V_{SS}		V_{DD}	V

Electrical Characteristics $V_{DD}=AV_{DD}=DV_{DD}=5.0V$, $AV_{SS}=DV_{SS}=0V$, $T_a=25^\circ C$

Parameter	Symbol	Conditions	min	typ	max	Unit
Power supply current	I_{DD}	$f_{CLK} = 15 \text{ MHz}$ (includes reference power supply)		18	26	mA
Resolution	RES			8		bit
Linearity error	E_L	$f_{CLK}=15\text{MHz}$		± 0.5	± 1.3	LSB
Differential linearity error	E_D	$V_{RT}=3.5V$ $V_{RB}=1.5V$		± 0.4	± 0.8	LSB
Maximum conversion rate	$F_{c(max.)}$		15			MSPS
Clock frequency	f_{CLK}		1		15	MHz
Analog input dynamic range	D_R		2		$V_{RT}-V_{RB}$	V
Output current	"H" level	I_{OH}	$V_{OH}=V_{DD}-0.8V$		-2	mA
	"L" level	I_{OL}	$V_{OL}=0.4V$	2		mA
Output delay time	t_d	$C_L=50\text{pF}$		25	40	ns
Analog input capacitance	C_I			18		pF

■ Timing Chart

The chip samples the analog input at the falling edge of the clock signal and provides the corresponding digital output 2.5 clock cycles later at the rising edge of the clock signal.

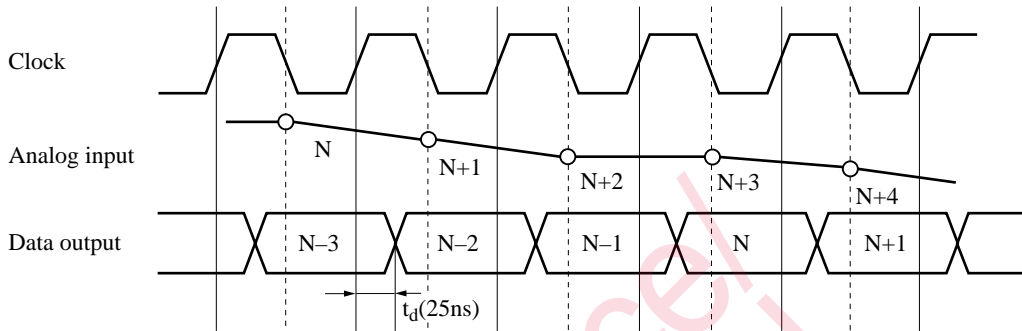

Note: The circles indicate analog signal sampling points.

■ Package Dimensions (Unit:mm)

SOP024-P-0375

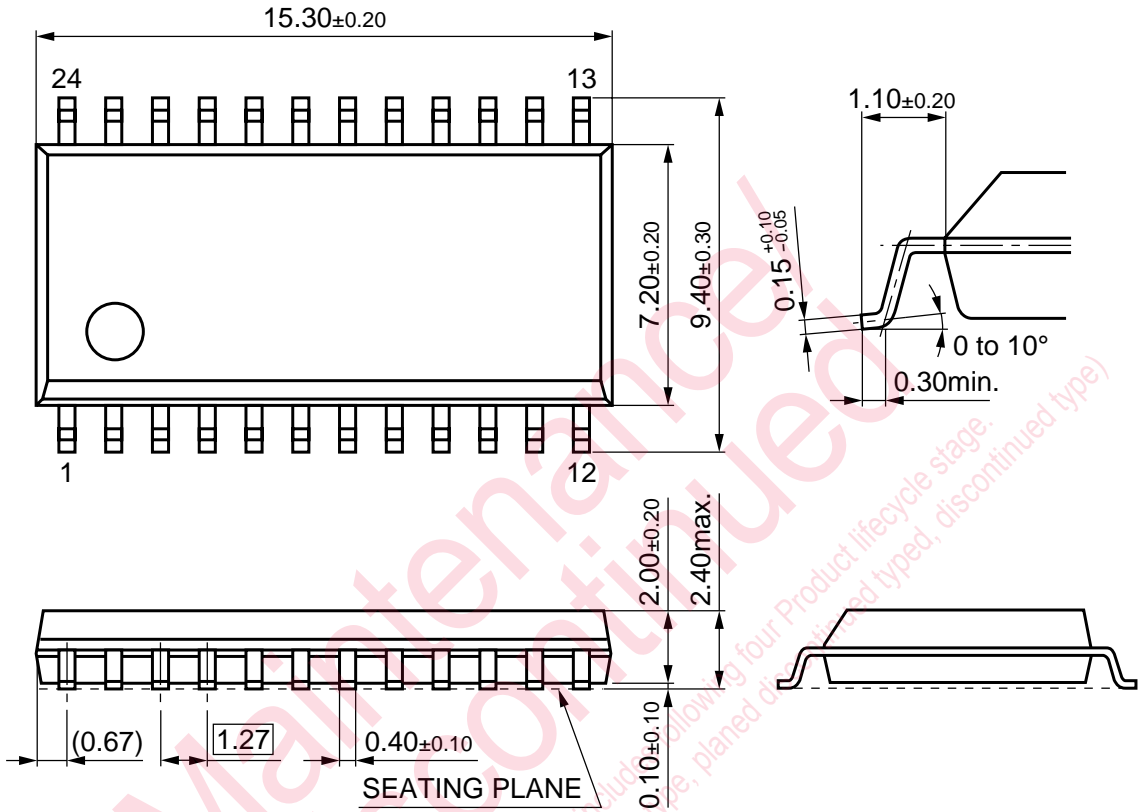

Request for your special attention and precautions in using the technical information and semiconductors described in this book

- (1) If any of the products or technical information described in this book is to be exported or provided to non-residents, the laws and regulations of the exporting country, especially, those with regard to security export control, must be observed.
- (2) The technical information described in this book is intended only to show the main characteristics and application circuit examples of the products, and no license is granted under any intellectual property right or other right owned by our company or any other company. Therefore, no responsibility is assumed by our company as to the infringement upon any such right owned by any other company which may arise as a result of the use of technical information described in this book.
- (3) The products described in this book are intended to be used for standard applications or general electronic equipment (such as office equipment, communications equipment, measuring instruments and household appliances).
Consult our sales staff in advance for information on the following applications:
 - Special applications (such as for airplanes, aerospace, automobiles, traffic control equipment, combustion equipment, life support systems and safety devices) in which exceptional quality and reliability are required, or if the failure or malfunction of the products may directly jeopardize life or harm the human body.
 - Any applications other than the standard applications intended.
- (4) The products and product specifications described in this book are subject to change without notice for modification and/or improvement. At the final stage of your design, purchasing, or use of the products, therefore, ask for the most up-to-date Product Standards in advance to make sure that the latest specifications satisfy your requirements.
- (5) When designing your equipment, comply with the range of absolute maximum rating and the guaranteed operating conditions (operating power supply voltage and operating environment etc.). Especially, please be careful not to exceed the range of absolute maximum rating on the transient state, such as power-on, power-off and mode-switching. Otherwise, we will not be liable for any defect which may arise later in your equipment.
 - Even when the products are used within the guaranteed values, take into the consideration of incidence of break down and failure mode, possible to occur to semiconductor products. Measures on the systems such as redundant design, arresting the spread of fire or preventing glitch are recommended in order to prevent physical injury, fire, social damages, for example, by using the products.
- (6) Comply with the instructions for use in order to prevent breakdown and characteristics change due to external factors (ESD, EOS, thermal stress and mechanical stress) at the time of handling, mounting or at customer's process. When using products for which damp-proof packing is required, satisfy the conditions, such as shelf life and the elapsed time since first opening the packages.
- (7) This book may be not reprinted or reproduced whether wholly or partially, without the prior written permission of Matsushita Electric Industrial Co., Ltd.