



Dear customers,

**About the change in the name such as "Oki Electric Industry Co. Ltd." and "OKI" in documents to OKI Semiconductor Co., Ltd.**

The semiconductor business of Oki Electric Industry Co., Ltd. was succeeded to OKI Semiconductor Co., Ltd. on October 1, 2008. Therefore, please accept that although the terms and marks of "Oki Electric Industry Co., Ltd.", "Oki Electric", and "OKI" remain in the documents, they all have been changed to "OKI Semiconductor Co., Ltd.". It is a change of the company name, the company trademark, and the logo, etc. , and NOT a content change in documents.

October 1, 2008  
OKI Semiconductor Co., Ltd.

**OKI SEMICONDUCTOR CO., LTD.**

550-1 Higashiasakawa-cho, Hachioji-shi, Tokyo 193-8550, Japan  
<http://www.okisemi.com/en/>

---

# OKI Semiconductor

## ML50000

### Echo Canceler

#### GENERAL DESCRIPTION

The ML50000 is an echo canceler with improved characteristics for the speakerphone applications, such as hands-free phones. (The ML50000 can also be used for line echo suppression.)

The ML50000 is a low power CMOS LSI device for canceling echo (in acoustic or line systems) generated in the communication path.

Using digital signal processing, the echo path is estimated and a pseudo-echo signal is generated to cancel the echo.

When used as an acoustic echo canceler, the device cancels the acoustic echo generated between a loud speaker and a microphone, occurring during hands-free communication such as when using a cellular phone or a conference system phone.

When used as a line echo canceler, the device cancels the line echo caused by hybrid impedance mismatching.

The ML50000 enables high quality telephone communication by preventing howling and controlling levels with howling detection, double talk detection, attenuator function, and gain control functions, and by suppressing low level noise with a center clipper function.

The I/O interface of the ML50000 supports  $\mu$ -law PCM.

Use of a single chip codec such as the MSM7704 (3V) or the MSM7533 (5V) allows economical and highly efficient echo canceller units to be configured.

#### FEATURES

- Compatible with echo paths that amplify E.R.L.
- An improved center clipper function (NLP) attenuates echo of 50 dB or more when NLP is used.
- Fast convergencetime (as compared to the MSM7620).
- Supports abrupt changes in the echo path. No need to reset for each communication.
- The gain control function (GC) becomes effective at the level of  $-10$  dBm0.
- Cancellable echo delay time:

ML50000-001 ..... For a single chip: 21 ms (max.)

ML50000-011 ..... For a cascade connection (can also be used for a single chip)  
 Master chip: 21 ms (max.)  
 Slave chip: 31 ms (max.)  
 Cancelable up to 207 ms (1 master plus 6 slaves)  
 For a single chip: 21 ms (max.)

- Echo attenuation : 30 dB (typ.)
- Clock frequency : 19.2 MHz  
17.5 to 20 MHz (when the internal sync signal is not used)
- Power supply voltage : 2.7 V to 5.5 V
- Package
  - 28 pin plastic SSOP (SSOP28-P-485-0.65-K) (Product name: ML50000-001GS-K)
  - 56 pin plastic QFP (QFP56-P-910-0.65-2K) (Product name: ML50000-011GS-2K)

**BLOCK DIAGRAM**  
**ML50000-001 (Single chip only)**

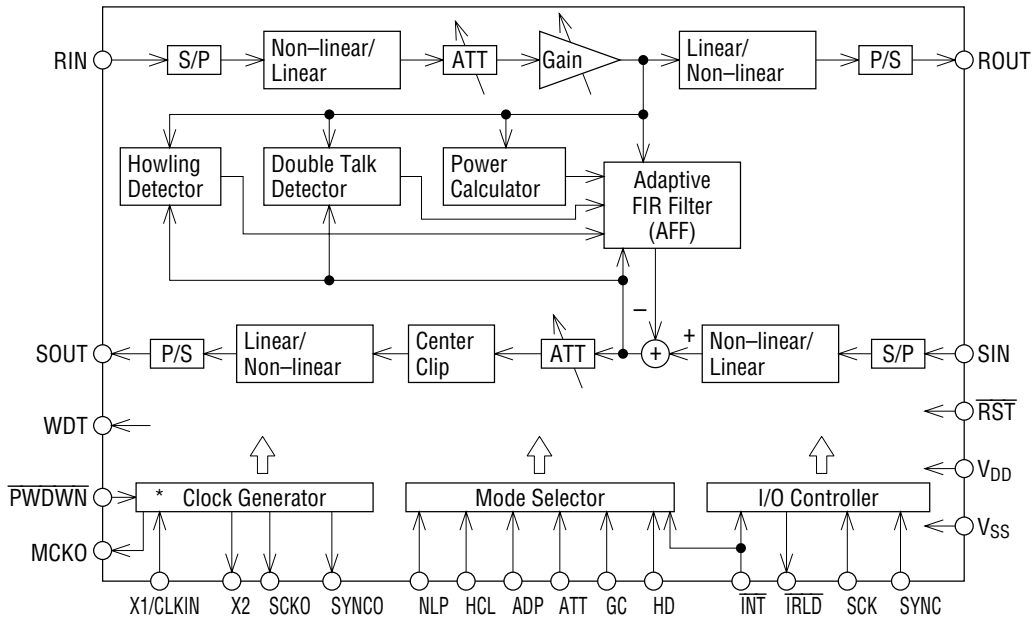

**ML50000-011 (Cascade connection or single chip)**

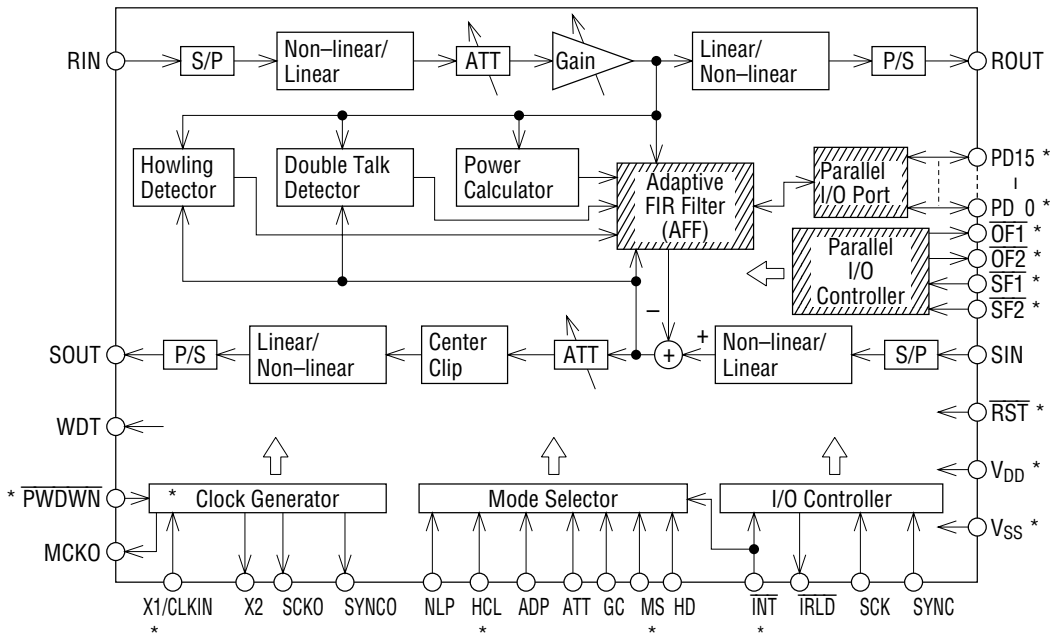

\* If the ML50000-011 is used in the slave mode, only the diagonally hatched blocks and the pins marked with \* are used.

**PIN CONFIGURATION (TOP VIEW)**

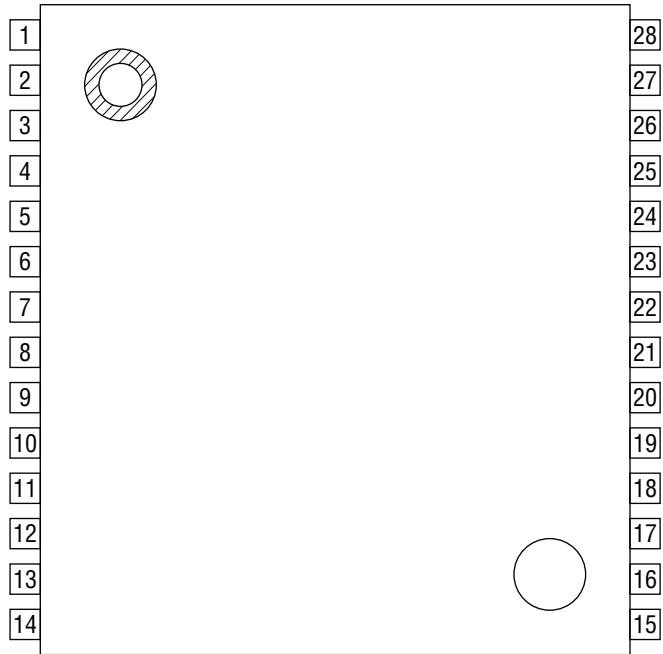

**28-Pin Plastic SSOP**

Pin	Symbol	Pin	Symbol	Pin	Symbol	Pin	Symbol
1	NLP	8	SIN	15	V <sub>SS</sub>	22	SYNCO
2	HCL	9	RIN	16	HD	23	SCKO
3	ADP	10	SCK	17	X1/CLKIN	24	$\overline{\text{RST}}$
4	V <sub>DD</sub>	11	SYNC	18	X2	25	WDT
5	ATT	12	SOUT	19	V <sub>DD</sub>	26	GC
6	$\overline{\text{INT}}$	13	ROUT	20	$\overline{\text{PWDWN}}$	27	V <sub>DD</sub>
7	$\overline{\text{IRLD}}$	14	V <sub>SS</sub>	21	V <sub>SS</sub>	28	MCKO

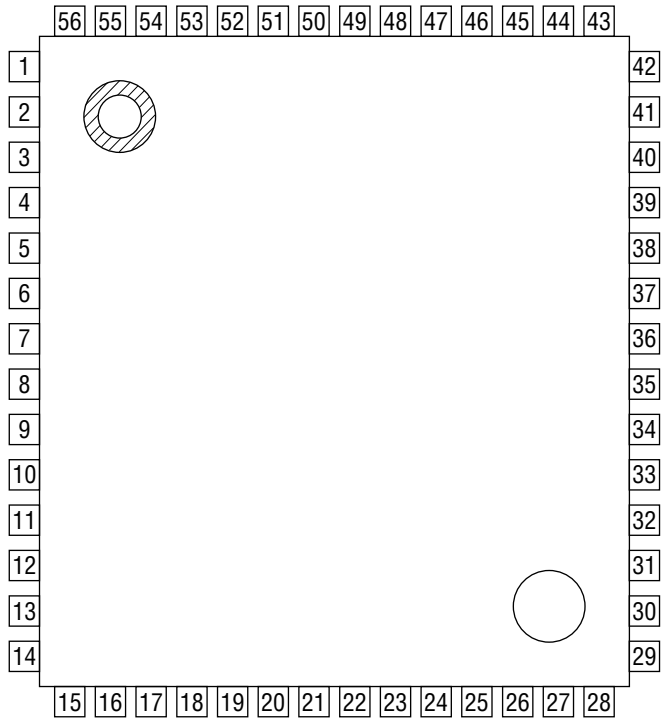

56-Pin Plastic QFP

Pin	Symbol	Pin	Symbol	Pin	Symbol	Pin	Symbol
1	NLP	15	PD0	29	PD12	43	*
2	HCL	16	PD1	30	PD13	44	PD14
3	ADP	17	PD2	31	X1/CLKIN	45	PD15
4	MS	18	PD3	32	X2	46	MCKO
5	ATT	19	PD4	33	V <sub>DD</sub>	47	$\overline{SF2}$
6	$\overline{INT}$	20	PD5	34	$\overline{PWDWN}$	48	$\overline{OF1}$
7	$\overline{IRLD}$	21	V <sub>SS</sub>	35	V <sub>SS</sub>	49	V <sub>SS</sub>
8	SIN	22	PD6	36	SYNCO	50	*
9	RIN	23	PD7	37	SCKO	51	V <sub>SS</sub>
10	SCK	24	PD8	38	$\overline{RST}$	52	$\overline{SF1}$
11	SYNC	25	PD9	39	WDT	53	$\overline{OF2}$
12	SOUT	26	PD10	40	GC	54	V <sub>DD</sub>
13	ROUT	27	PD11	41	V <sub>DD</sub>	55	V <sub>DD</sub>
14	V <sub>SS</sub>	28	HD	42	V <sub>DD</sub>	56	*

\*: No connect pin

## PIN DESCRIPTIONS (1/5)

Pin		Symbol	Type	Description
28-pin SSOP	56-pin QFP			
1	1	NLP	I	<p>Control pin for the center clipping function.</p> <p>This pin forces the SOUT output to a minimum value when the SOUT signal is below <math>-36</math> dBm0. Effective for reducing low-level noise.</p> <ul style="list-style-type: none"> <li>• Single Chip or Master Chip in a Cascade Connection <ul style="list-style-type: none"> <li>"H": Center clip ON</li> <li>"L": Center clip OFF</li> </ul> </li> <li>• Slave Chip in a Cascade Connection <ul style="list-style-type: none"> <li>Fixed at "L"</li> </ul> </li> </ul> <p>This input signal is loaded in synchronization with the falling edge of the <math>\overline{\text{INT}}</math> signal or the rising edge of the <math>\overline{\text{RST}}</math> signal.</p>
2	2	HCL	I	<p>Through mode control.</p> <p>When this pin is in the through mode, RIN and SIN data is output to ROUT and SOUT. At the same time, the coefficient of the adaptive FIR filter is cleared.</p> <ul style="list-style-type: none"> <li>• Single Chip or Master Chip in a Cascade Connection <ul style="list-style-type: none"> <li>"H": Through mode</li> <li>"L": Normal mode (echo canceler operates)</li> </ul> </li> <li>• Slave Chip in a Cascade Connection <ul style="list-style-type: none"> <li>Same as master</li> </ul> </li> </ul> <p>This input signal is loaded in synchronization with the falling edge of the <math>\overline{\text{INT}}</math> signal or the rising edge of the <math>\overline{\text{RST}}</math> signal.</p>
3	3	ADP	I	<p>AFF coefficient control.</p> <p>This pin stops updating of the adaptive FIR filter (AFF) coefficient and sets the coefficient to a fixed value, when this pin is configured to be the coefficient fix mode.</p> <p>This pin is used when holding the AFF coefficient which has been once converged.</p> <ul style="list-style-type: none"> <li>• Single Chip or Master Chip in a Cascade Connection <ul style="list-style-type: none"> <li>"H": Coefficient fix mode</li> <li>"L": Normal mode (coefficient update)</li> </ul> </li> <li>• Slave Chip in a Cascade Connection <ul style="list-style-type: none"> <li>Fixed at "L"</li> </ul> </li> </ul> <p>This input signal is loaded in synchronization with the falling edge of the <math>\overline{\text{INT}}</math> signal or the rising edge of the <math>\overline{\text{RST}}</math> signal.</p>
—	4	MS	I	<p>Select signal.</p> <p>This pin selects between the master chip and slave chip when used in a cascade connection.</p> <ul style="list-style-type: none"> <li>"L": Single chip or master chip</li> <li>"H": Slave chip</li> </ul>

(2/5)

Pin		Symbol	Type	Description
28-pin SSOP	56-pin QFP			
5	5	ATT	I	<p>Control for the ATT function.</p> <p>This pin prevents howling by attenuators (ATT) for the RIN input and SOUT output.</p> <p>If there is input only to RIN, the ATT for the SOUT output is activated.</p> <p>If there is no input to SIN, or if there is input to both SIN and RIN, the ATT for the RIN input is activated.</p> <p>Either the ATT for the RIN output or the ATT for the SOUT is always activated in all cases, and the attenuation of ATT is 6 dB.</p> <ul style="list-style-type: none"> <li>• Single Chip or Master Chip in a Cascade Connection "H": ATT OFF "L": ATT ON "L" is recommended if performing echo cancellation.</li> <li>• Slave Chip in a Cascade Connection Fixed at "L"</li> </ul> <p>This input signal is loaded in synchronization with the falling edge of the <math>\overline{\text{INT}}</math> signal or the rising edge of the <math>\overline{\text{RST}}</math> signal.</p>
6	6	$\overline{\text{INT}}$	I	<p>Interrupt signal which starts 1 cycle (8 kHz) of the signal processing. Signal processing starts when "H"-to-"L" transition is detected.</p> <ul style="list-style-type: none"> <li>• Single Chip or Master Chip in a Cascade Connection Connect the <math>\overline{\text{IRLD}}</math> pin.</li> <li>• Slave Chip in a Cascade Connection Connect the <math>\overline{\text{IRLD}}</math> pin of the master chip.</li> </ul> <p><math>\overline{\text{INT}}</math> input is invalid for 100 <math>\mu\text{s}</math> after reset due to initialization.</p> <p>Refer to the control pin connection example.</p>
7	7	$\overline{\text{IRLD}}$	O	<p>Load detection signal output when the SIN and RIN serial input data is loaded in the internal registers.</p> <ul style="list-style-type: none"> <li>• Single Chip Connect to the <math>\overline{\text{INT}}</math> pin.</li> <li>• Master Chip in a Cascade Connection Connect to the <math>\overline{\text{INT}}</math> pin of the master chip and all the slave chips.</li> <li>• Slave Chip in a Cascade Connection Leave open.</li> </ul> <p>Refer to the control pin connection example.</p>
8	8	SIN	I	<p>Transmit serial data.</p> <p>Input the PCM signal synchronized to SYNC and SCK. Data is read in at the falling edge of SCK.</p>
9	9	RIN	I	<p>Receive serial data.</p> <p>Input the PCM signal synchronized to SYNC and SCK. Data is read at the falling edge of SCK.</p>
10	10	SCK	I	<p>Clock input for transmit/receive serial data.</p> <p>This pin uses the external SCK or the SCKO.</p> <p>Input the PCM CODEC transmit/receive clock (64 to 2048 kHz).</p>

(3/5)

Pin		Symbol	Type	Description
28-pin SSOP	56-pin QFP			
11	11	SYNC	I	Sync signal for transmit/receive serial data. This pin uses the external SYNC or SYNCO. Input the PCM CODEC transmit/receive sync signal (8 kHz).
12	12	SOUT	O	Transmit serial data. Outputs the PCM signal synchronized to SYNC and SCK. This pin is in a high impedance state during no data output.
13	13	ROUT	O	Receive serial data. Outputs the PCM signal synchronized to SYNC and SCK. This pin is in a high impedance state during no data output.
—	15	PD0	I/O	This is the bidirectional bus pin for parallel data transfer between the master chip and slave chip when used in a cascade connection. The PD15 pin corresponds to MSB. This pin is in a high impedance state during no data output. Data is loaded in at the falling edge of $\overline{SFX}$ .
—	20	PD5		
—	22	PD6		
—	27	PD11		
—	29	PD12		
—	30	PD13		
—	44	PD14		
—	45	PD15		
16	28	HD	I	Controls the howling detect function. This pin detects and cancels a howling generated during hand-free talking for acoustic system. This function is used to cancel acoustic echoes. <ul style="list-style-type: none"> <li>• Single Chip or Master Chip in a Cascade Connection <ul style="list-style-type: none"> <li>"L": Howling detector ON</li> <li>"H": Howling detector OFF</li> </ul> </li> <li>• Slave Chip in a Cascade Connection <ul style="list-style-type: none"> <li>Fixed at "L"</li> </ul> </li> </ul>
17	31	X1/CLKIN	I	External input for the basic clock (17.5 to 20 MHz) or for the crystal oscillator. When the internal sync signal (SYNCO, SCKO) is used, input the basic clock of 19.2 MHz.
18	32	X2	O	Crystal oscillator output. Used to configure the oscillation circuit. Refer to the internal clock generator circuit example.

(4/5)

Pin		Symbol	Type	Description
28-pin SSOP	56-pin QFP			
20	34	PWDWN	I	Power-down mode control when powered down. "L": Power-down mode "H": Normal operation mode During power-down mode, all input pins are disabled and output pins are in the following states : High impedance : SOUT, ROUT, PD0 to 15 "L": SYNCO, SCKO, MCKO "H": OF1, OF2, X2 Holds the last state : WDT, IRLD Reset after the power-down mode is released.
22	36	SYNCO	0	8 kHz sync signal for the PCM CODEC. Connect to the SYNC pin and the PCMCODEC transmit/receive sync pin. Leave it open if using an external SYNC.
23	37	SCKO	0	Transmit clock signal (256 kHz) for the PCM CODEC. Connect to the SCK pin and the PCM CODEC transmit/receive clock pin. Leave it open if using an external SCK.
24	38	RST	I	Reset signal. "L": Reset mode "H": Normal operation mode Due to initialization, input signals are disabled for 100 μs after reset (after RST is returned from L to H). Input the basic clock during the reset. Output pins during the reset are in the following states : High impedance: SOUT, ROUT, PD0 to 15 "L": WDT "H": OF1, OF2 Not affected: X2, SYNCO, SCKO, IRLD, MCKO
25	39	WDT	0	Test program end signal. This signal is output when the one cycle (8kHz) of processing is completed. Leave it open.
26	40	GC	I	Input signal by which the gain controller for the RIN input is controlled and the RIN input level is controlled and howling is prevented. The gain controller adjusts the RIN input level when it is -10 dBm0 or above. RIN input levels from -10 to -1.5 dBm0 will be suppressed to -10 dBm0 in the attenuation range from 0 to 8.5 dB. RIN input levels above -1.5 dBm0 will always be attenuated by 8.5 dB. • Single Chip or Master Chip in a Cascade Connection "H": Gain control ON "L": Gain control OFF "H" is recommended for echo cancellation. • Slave Chip in a Cascade Connection Fixed at "L" This pin is loaded in synchronization with the falling edge of the INT signal or the rising edge of RST.

(5/5)

Pin		Symbol	Type	Description
28-pin SSOP	56-pin QFP			
28	46	MCKO	0	Basic clock.
—	47	$\overline{SF2}$	1	Parallel data transfer flag. <ul style="list-style-type: none"> <li>• Single Chip Fixed at "H"</li> <li>• Master Chip in a Cascade Connection Fixed at "H"</li> <li>• Slave Chip in a Cascade Connection Connect <math>\overline{OF2}</math> of the master chip to the 1st stage slave chip. Connect <math>\overline{OF1}</math> of the previous stage slave chip to the 2nd and later stage slave chips. Refer to the control pin connection example.</li> </ul>
—	48	$\overline{OF1}$	0	Parallel data transfer flag. <ul style="list-style-type: none"> <li>• Single Chip Leave open.</li> <li>• Master Chip in a Cascade Connection Connect to the <math>\overline{SF1}</math> of all slaves.</li> <li>• Slave chip in a Cascade Connection Connect to the <math>\overline{SF2}</math> of the next stage slave chip. Connect the last stage slave chip to the <math>\overline{SF1}</math> of the master chip. Refer to the control pin connection example.</li> </ul>
—	52	$\overline{SF1}$	1	Parallel data transfer flag. <ul style="list-style-type: none"> <li>• Single Chip Connect <math>\overline{OF2}</math>.</li> <li>• Master Chip in a Cascade Connection Connect <math>\overline{OF1}</math> of the last stage slave chip.</li> <li>• Slave Chip in a Cascade Connection Connect <math>\overline{OF1}</math> of master chip for all slave chips. Refer to the control pin connection example.</li> </ul>
—	53	$\overline{OF2}$	0	Parallel data output flag. <ul style="list-style-type: none"> <li>• Single Chip Connect to <math>\overline{SF1}</math>.</li> <li>• Master Chip in a Cascade Connection Connect to <math>\overline{SF2}</math> of the 1st stage slave chip.</li> <li>• Slave Chip in a Cascade Connection Leave open. Refer to the control pin connection example.</li> </ul>

**ABSOLUTE MAXIMUM RATINGS**

Parameter	Symbol	Condition	Rating	Unit
Power Supply Voltage	V <sub>DD</sub>	T <sub>a</sub> = 25°C	-0.3 to +7	V
Input Voltage	V <sub>IN</sub>		-0.3 to V <sub>DD</sub> + 0.3	V
Power Dissipation	P <sub>D</sub>		1	W
Storage Temperature	T <sub>STG</sub>	—	-55 to +150	°C

**RECOMMENDED OPERATING CONDITIONS**

(V<sub>DD</sub> = 2.7 V to 3.6 V)

Parameter	Symbol	Condition	Min.	Typ.	Max.	Unit
Power Supply Voltage	V <sub>DD</sub>	—	2.7	3.3	3.6	V
Power Supply Voltage	V <sub>SS</sub>	—	—	0	—	V
High Level Input Voltage	V <sub>IH</sub>	Pins other than X1	2.0	—	V <sub>DD</sub>	V
		X1 pin	2.2	—	V <sub>DD</sub>	V
Low Level Input Voltage	V <sub>IL</sub>	—	0	—	0.5	V
Operating Temperature	T <sub>a</sub>	—	-40	+25	+85	°C

(V<sub>DD</sub> = 4.5 V to 5.5 V)

Parameter	Symbol	Condition	Min.	Typ.	Max.	Unit
Power Supply Voltage	V <sub>DD</sub>	—	4.5	5	5.5	V
Power Supply Voltage	V <sub>SS</sub>	—	—	0	—	V
High Level Input Voltage	V <sub>IH</sub>	Pins other than X1, SCK	2.4	—	V <sub>DD</sub>	V
		X1, SCK pins	3.5	—	V <sub>DD</sub>	V
Low Level Input Voltage	V <sub>IL</sub>	—	0	—	0.8	V
Operating Temperature	T <sub>a</sub>	—	-40	+25	+85	°C

**ELECTRICAL CHARACTERISTICS**

**DC Characteristics**

(V<sub>DD</sub> = 2.7 V to 3.6 V, T<sub>a</sub> = -40°C to +85°C)

Parameter	Symbol	Condition	Min.	Typ.	Max.	Unit	
High Level Output Voltage	V <sub>OH</sub>	I <sub>OH</sub> = 40 μA	2.2	—	V <sub>DD</sub>	V	
Low Level Output Voltage	V <sub>OL</sub>	I <sub>OL</sub> = 1.6 mA	0	—	0.4	V	
High Level Input Current	I <sub>IH</sub>	V <sub>IH</sub> = V <sub>DD</sub>	—	0.1	1	μA	
		MS with pull-down	6	60	120	μA	
Low Level Input Current	I <sub>IL</sub>	V <sub>IL</sub> = V <sub>SS</sub>	-1	-0.1	—	μA	
		SF1, SF2 with pull-up	-60	-33	-6	μA	
High Level Output Leakage Current	I <sub>OZH</sub>	V <sub>OH</sub> = V <sub>DD</sub>	—	0.1	1	μA	
Low Level Output Leakage Current	I <sub>OZL</sub>	V <sub>OL</sub> = V <sub>SS</sub>	PD15 to PD0 with pull-up	-60	-33	-6	μA
			Input other than the above	-1	-0.1	—	μA
Power Supply Current (Operating)	I <sub>DDO</sub>	—	—	20	30	mA	
Power Supply Current (Stand-by)	I <sub>DDS</sub>	PWDWN = "L"	—	10	50	μA	
Input Capacitance	C <sub>I</sub>	—	—	—	15	pF	
Output Load Capacitance	C <sub>LOAD</sub>	—	—	—	20	pF	

(V<sub>DD</sub> = 4.5 V to 5.5 V, T<sub>a</sub> = -40°C to +85°C)

Parameter	Symbol	Condition	Min.	Typ.	Max.	Unit	
High Level Output Voltage	V <sub>OH</sub>	I <sub>OH</sub> = 40 μA	4.2	—	V <sub>DD</sub>	V	
Low Level Output Voltage	V <sub>OL</sub>	I <sub>OL</sub> = 1.6 mA	0	—	0.4	V	
High Level Input Current	I <sub>IH</sub>	V <sub>IH</sub> = V <sub>DD</sub>	—	0.1	10	μA	
		MS with pull-down	10	100	200	μA	
Low Level Input Current	I <sub>IL</sub>	V <sub>IL</sub> = V <sub>SS</sub>	-10	-0.1	—	μA	
		SF1, SF2 with pull-up	-100	-50	-10	μA	
High Level Output Leakage Current	I <sub>OZH</sub>	V <sub>OH</sub> = V <sub>DD</sub>	—	0.1	10	μA	
Low Level Output Leakage Current	I <sub>OZL</sub>	V <sub>OL</sub> = V <sub>SS</sub>	PD15 to PD0 with pull-up	-100	-50	-10	μA
			Input other than the above	-10	-0.1	—	μA
Power Supply Current (Operating)	I <sub>DDO</sub>	—	—	30	45	mA	
Input Capacitance	I <sub>DDS</sub>	PWDWN = "L"	—	10	50	μA	
Input Capacitance	C <sub>I</sub>	—	—	—	15	pF	
Output Load Capacitance	C <sub>LOAD</sub>	—	—	—	20	pF	

**Echo Canceler Characteristics (Refer to Characteristics Diagram)**

Parameter	Symbol	Condition	Min.	Typ.	Max.	Unit
Echo Attenuation	L <sub>RES</sub>	R <sub>IN</sub> = -10 dBm0 (5 kHz band white noise) E. R. L. (echo return loss) = 6 dB T <sub>D</sub> = 20 ms ATT, GC, NLP: OFF	—	30	—	dB
Cancelable Echo Delay Time for a Single Chip or a Master Chip in a Cascade	T <sub>D</sub>	R <sub>IN</sub> = -10 dBm0 (5 kHz band white noise) E. R. L. = 6 dB	—	—	21	ms
Cancelable Echo Delay Time for a Slave Chip in a Cascade	T <sub>DS</sub>	ATT, GC, NLP: OFF	—	—	31	ms

AC Characteristics

(Ta = -40°C to +85°C)

Parameter	Symbol	V <sub>DD</sub> = 2.7 V to 3.6 V			V <sub>DD</sub> = 4.5 V to 5.5 V			Unit
		Min.	Typ.	Max.	Min.	Typ.	Max.	
Clock Frequency	f <sub>C</sub>	—	19.2	—	—	19.2	—	MHz
When Internal Sync Signal is not used		17.5	—	20	17.5	—	20	
Clock Cycle Time	t <sub>MCK</sub>	—	52.08	—	—	52.08	—	ns
When Internal Sync Signal is not used		50	—	57.14	50	—	57.14	
Clock Duty Ratio	t <sub>DMC</sub>	40	—	60	40	—	60	ns
Clock "H" Level Pulse Width f <sub>C</sub> = 19.2 MHz	t <sub>MCH</sub>	20.8	—	31.3	20.8	—	31.3	ns
Clock "L" Level Pulse Width f <sub>C</sub> = 19.2 MHz	t <sub>MCL</sub>	20.8	—	31.3	20.8	—	31.3	ns
Clock Rise Time	t <sub>r</sub>	—	—	5	—	—	5	ns
Clock Fall Time	t <sub>f</sub>	—	—	5	—	—	5	ns
Sync Clock Output Time	t <sub>DCM</sub>	—	—	30	—	—	30	ns
Internal Sync Clock Frequency	f <sub>CO</sub>	—	256	—	—	256	—	kHz
Internal Sync Clock Output Cycle Time	t <sub>CO</sub>	—	3.9	—	—	3.9	—	μs
Internal Sync Clock Duty Ratio	t <sub>DCO</sub>	—	50	—	—	50	—	%
Internal Sync Signal Output Delay Time	t <sub>DCC</sub>	—	—	5	—	—	5	ns
Internal Sync Signal Period	t <sub>CYO</sub>	—	125	—	—	125	—	μs
Internal Sync Signal Output Width	t <sub>WSO</sub>	—	t <sub>CO</sub>	—	—	t <sub>CO</sub>	—	μs
Transmit/receive Operation Clock Frequency	f <sub>SCK</sub>	64	—	2048	64	—	2048	kHz
Transmit/receive Sync Clock Cycle Time	t <sub>SCK</sub>	0.488	—	15.6	0.488	—	15.6	μs
Transmit/receive Sync Clock Duty Ratio	t <sub>DSC</sub>	40	50	60	40	50	60	%
Transmit/receive Sync Signal Period	t <sub>CYC</sub>	123	125	—	123	125	—	μs
Sync Timing	t <sub>XS</sub>	45	—	—	45	—	—	ns
	t <sub>SX</sub>	45	—	t <sub>CYC</sub> -t <sub>SCK</sub>	45	—	t <sub>CYC</sub> -t <sub>SCK</sub>	ns
Sync Signal Width	t <sub>WSY</sub>	t <sub>SCK</sub>	—	—	t <sub>SCK</sub>	—	—	μs
Receive Signal Setup Time	t <sub>DS</sub>	45	—	—	45	—	—	ns
Receive Signal Hold Time	t <sub>DH</sub>	45	—	—	45	—	—	ns
Receive Data Input Time	t <sub>ID</sub>	—	7t <sub>SCK</sub>	—	—	7t <sub>SCK</sub>	—	μs
IRLD Signal Output Delay Time	t <sub>DIC</sub>	—	—	138	—	—	138	ns
IRLD Signal Output Width	t <sub>WIR</sub>	—	t <sub>SCK</sub>	—	—	t <sub>SCK</sub>	—	μs
Serial Output Delay Time	t <sub>SD</sub>	—	—	90	—	—	90	ns
	t <sub>XD</sub>	—	—	90	—	—	90	ns
Reset Signal Input Width	t <sub>WR</sub>	1	—	—	1	—	—	μs
Reset Start Time	t <sub>DRS</sub>	5	—	—	5	—	—	ns
Reset End Time	t <sub>DRE</sub>	—	—	52	—	—	52	ns
Processing Operation Start Time	t <sub>DIT</sub>	100	—	—	100	—	—	μs

## AC Characteristics (Continued)

(Ta = -40°C to +85°C)

Parameter	Symbol	V <sub>DD</sub> = 2.7 V to 3.6 V			V <sub>DD</sub> = 4.5 V to 5.5 V			Unit
		Min.	Typ.	Max.	Min.	Typ.	Max.	
Power Down Start Time	t <sub>DPS</sub>	—	—	111	—	—	111	ns
Power Down End Time	t <sub>DPE</sub>	—	—	15	—	—	15	ns
Control Pin Setup Time ( $\overline{\text{INT}}$ )	t <sub>DTS</sub>	20	—	—	20	—	—	ns
Control Pin Hold Time ( $\overline{\text{INT}}$ )	t <sub>DTH</sub>	120	—	—	120	—	—	ns
Control Pin Setup Time ( $\overline{\text{RST}}$ )	t <sub>DSR</sub>	20	—	—	20	—	—	ns
Control Pin Hold Time ( $\overline{\text{RST}}$ )	t <sub>DHR</sub>	10	—	—	10	—	—	ns
Parallel Data Output Signal Width	t <sub>WPD</sub>	—	2t <sub>MCK</sub>	—	—	2t <sub>MCK</sub>	—	ns
Flag Signal Output Time	t <sub>DF</sub>	—	t <sub>MCK</sub>	—	—	t <sub>MCK</sub>	—	ns
Flag Signal Output Width	t <sub>WFO</sub>	—	t <sub>MCK</sub> /2	—	—	t <sub>MCK</sub> /2	—	ns
Flag Signal Input Width	t <sub>WFI</sub>	—	t <sub>WFO</sub>	—	—	t <sub>WFO</sub>	—	ns
Data Read Setup Time	t <sub>FS</sub>	—	20	—	—	20	—	ns
Data Read Hold Time	t <sub>FH</sub>	—	10	—	—	10	—	ns

**TIMING DIAGRAM**  
**Clock Timing**

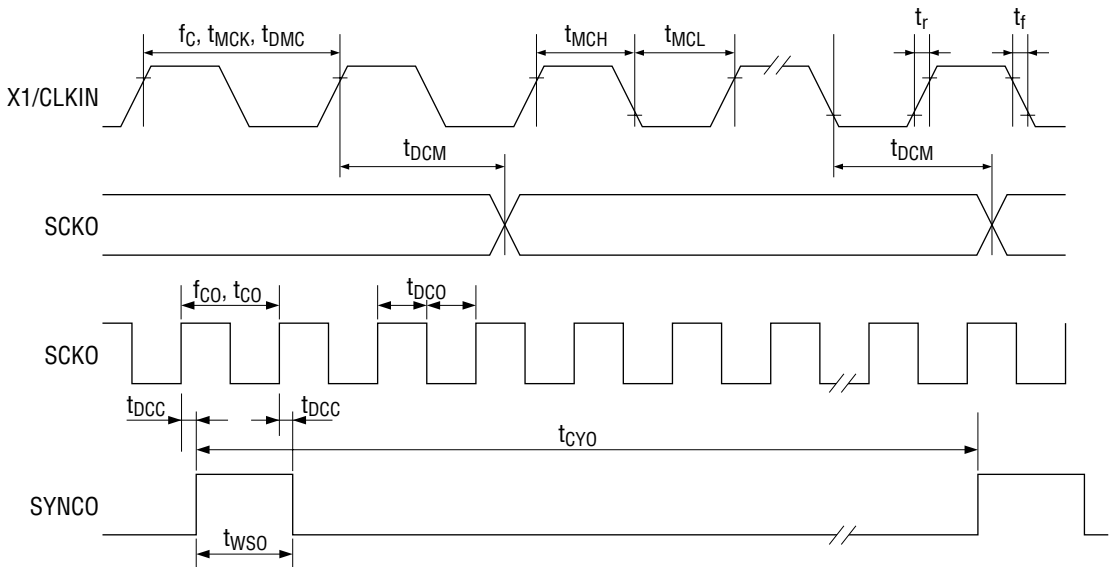

**Serial Input Timing**

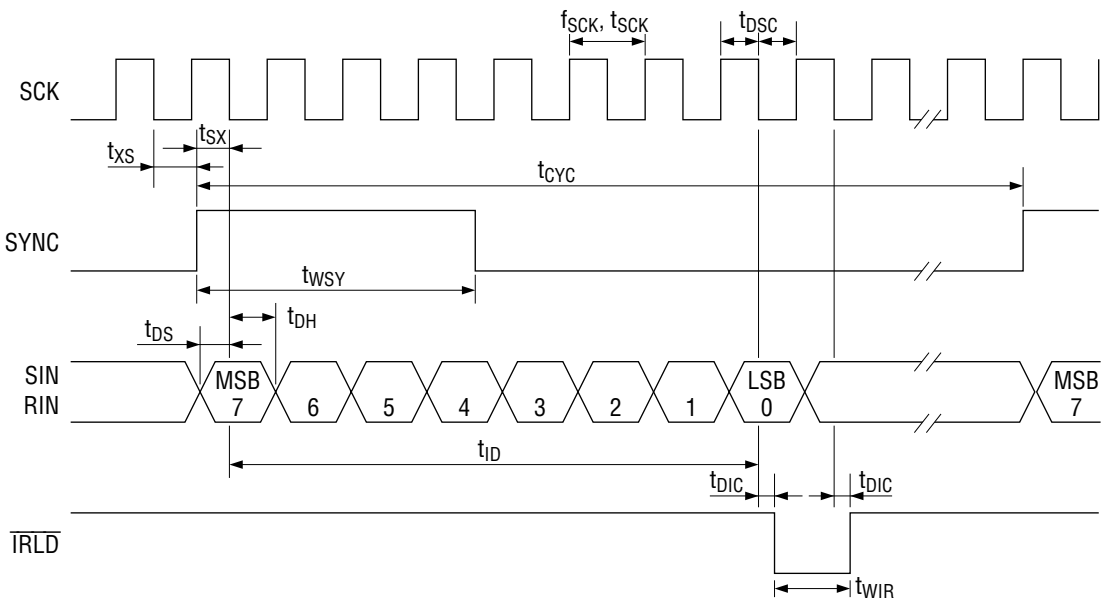

**Serial Output Timing**

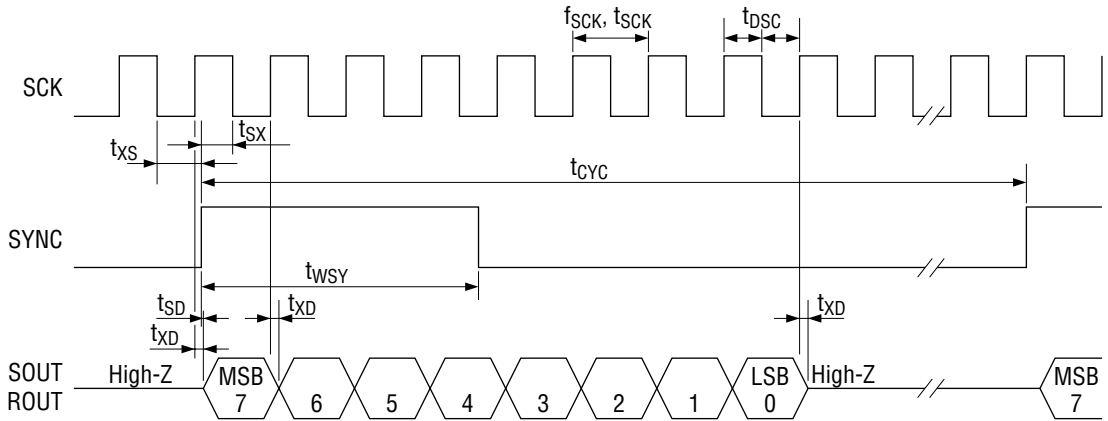

**Operation Timing After Reset**

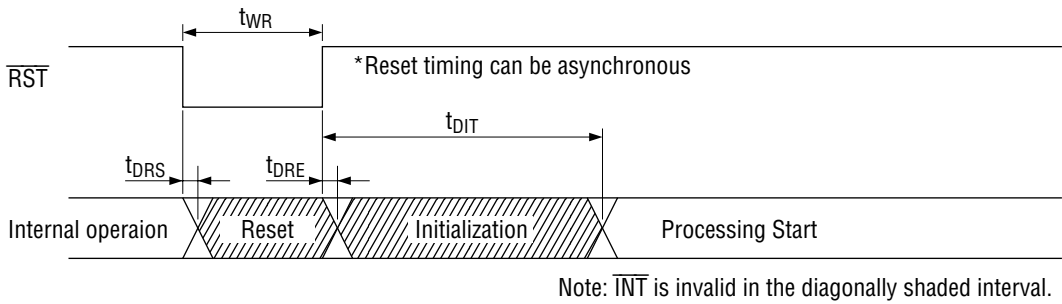

**Power Down Timing**

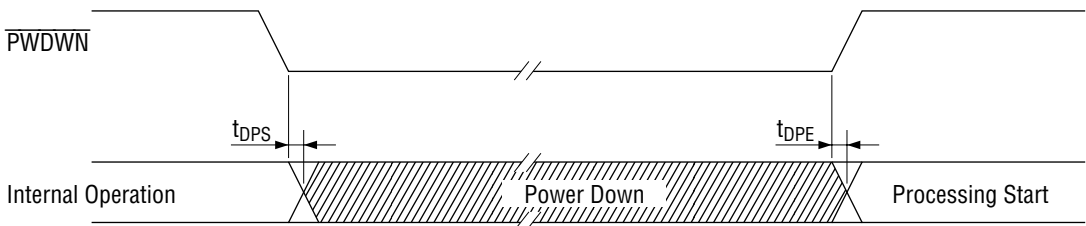

**Control Pin Load-in Timing**

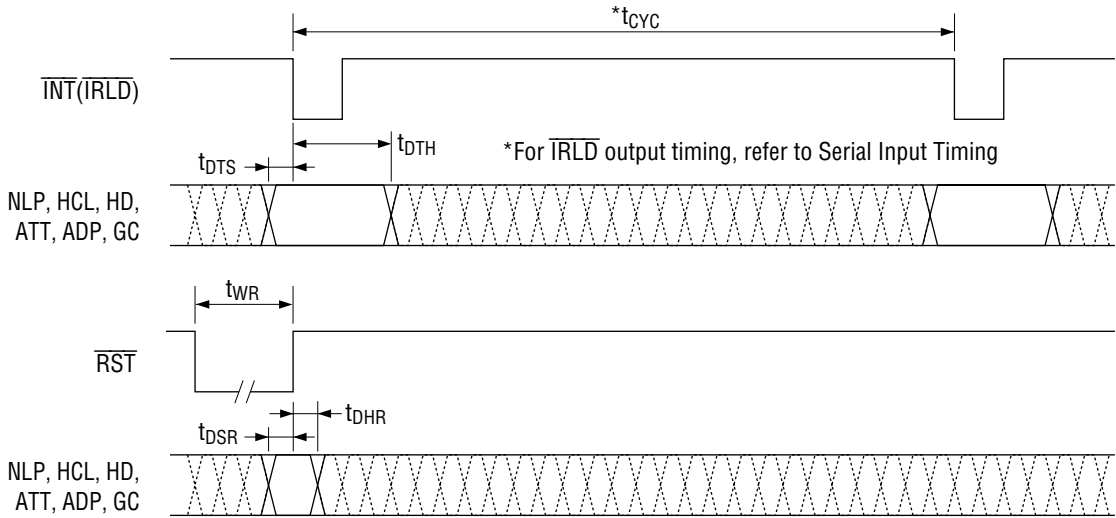

**Parallel Output Timing**

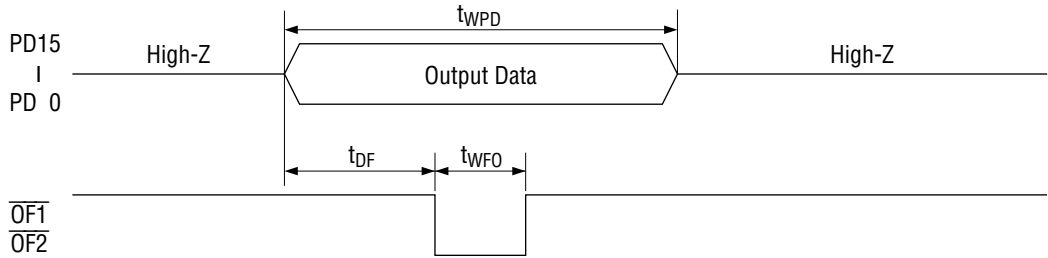

**Parallel Input Timing**

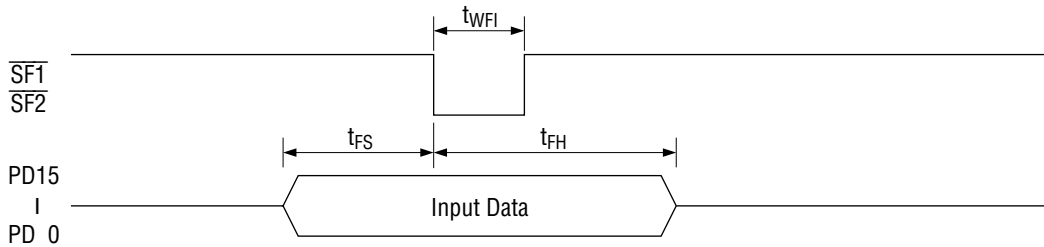

### HOW TO USE THE ML50000

The ML50000 cancels (based on the RIN signal) the echo which returns to SIN. Connect the base signal to the R side and the echo generated signal to the S side.

#### Connection Methods According to Echos

Example 1: Canceling acoustic echo (to handle acoustic echo from line input)

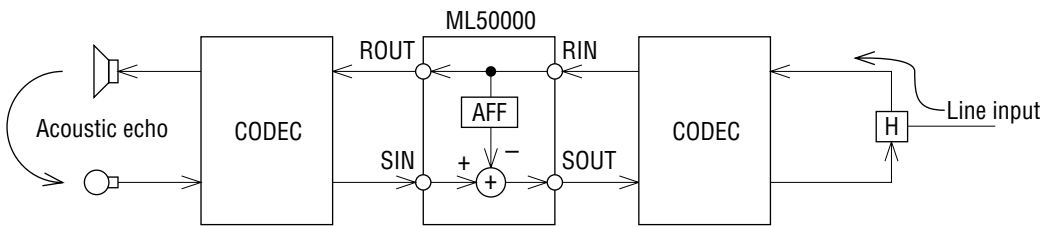

Example 2: Canceling line echo (to handle line echo from microphone input)

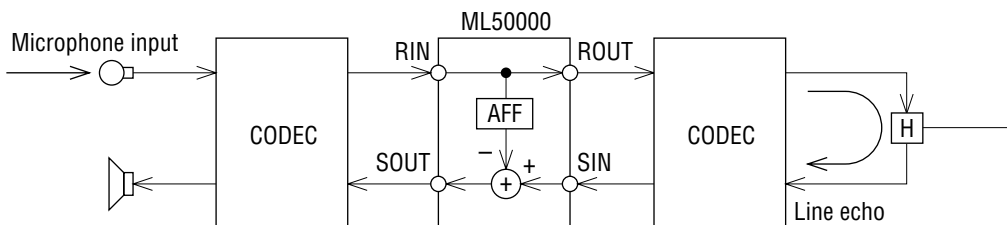

Example 3: Canceling line echo in a cascade connection (to handle line echo from microphone input)

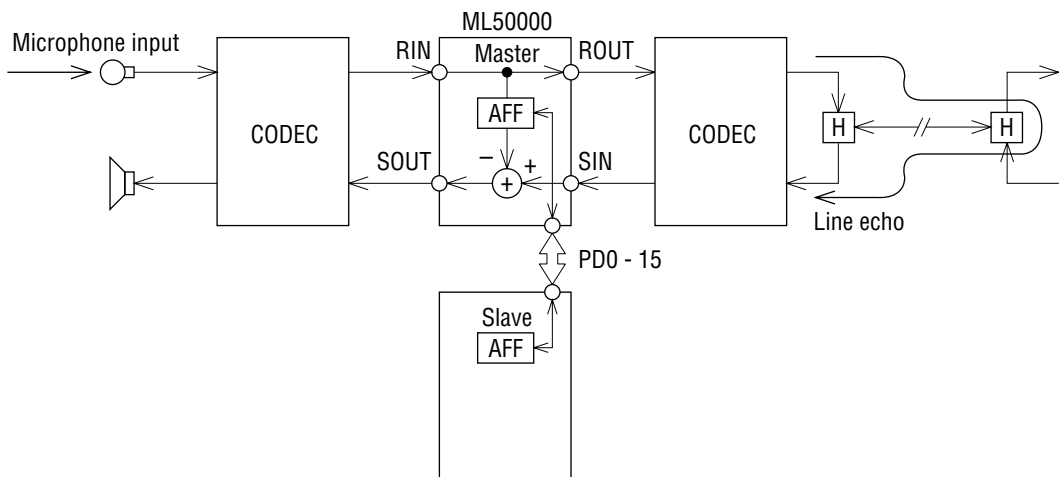

Example 4: Canceling of both acoustic echo and line echo  
 (to handle both acoustic echo from line input and line echo from microphone input)

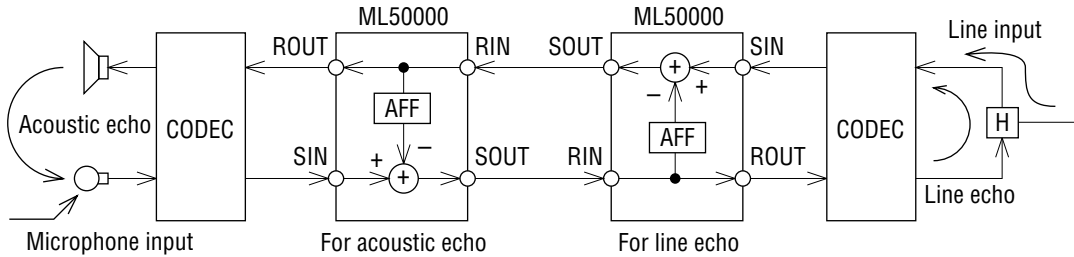

**Control Pin Connection Example**

Single chip connection

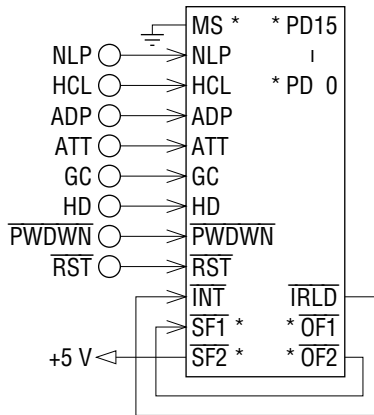

Asterisk (\*) indicates a pin only for the ML50000-011

2-stage cascade connection  
 Master + (slave × 1)

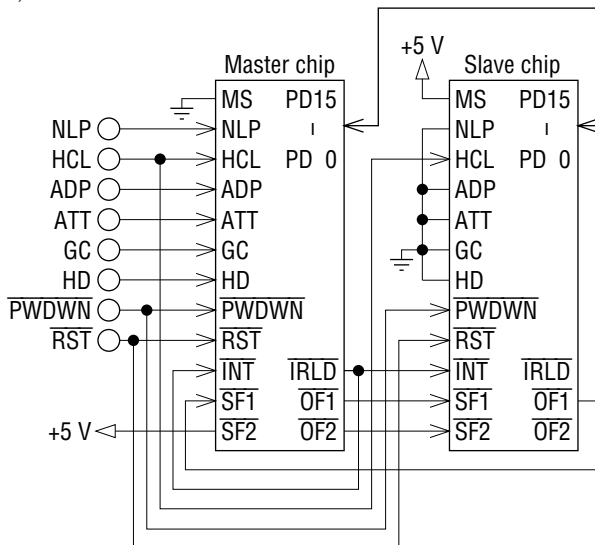

4-stage cascade connection  
 Master + (slave × 3)

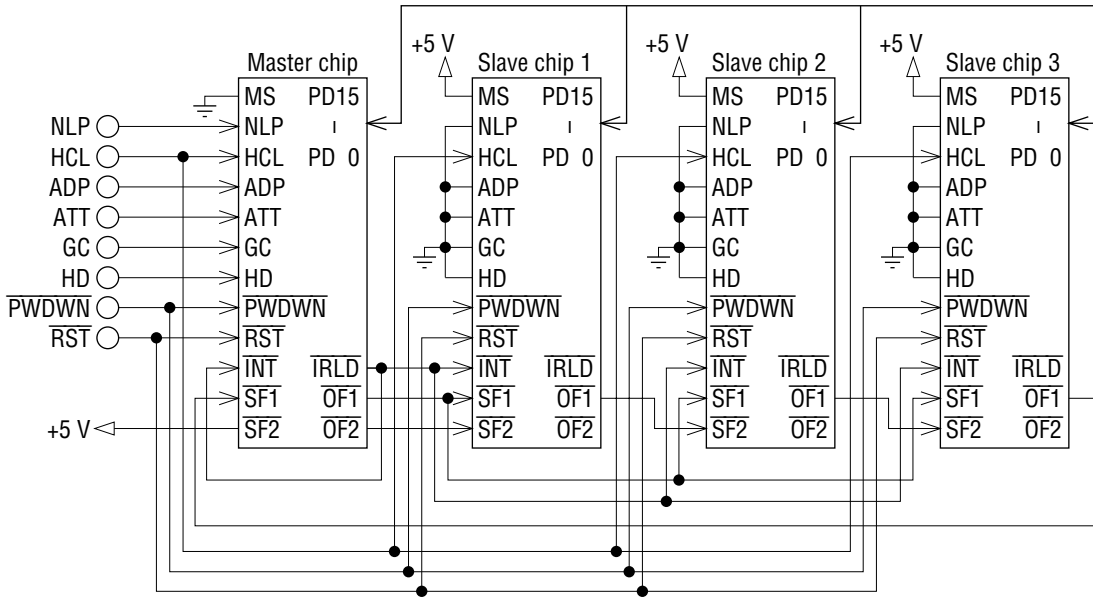

Internal Clock Generator Circuit Example

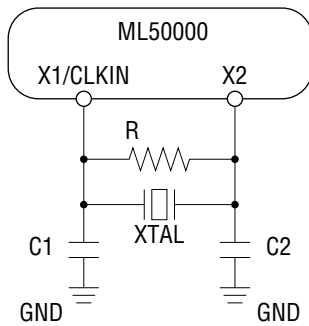

- XTAL : 19.2 MHz
- R : 1 MΩ
- C1 : 27 pF
- C2 : 27 pF

ECHO CANCELER CHARACTERISTICS DIAGRAM

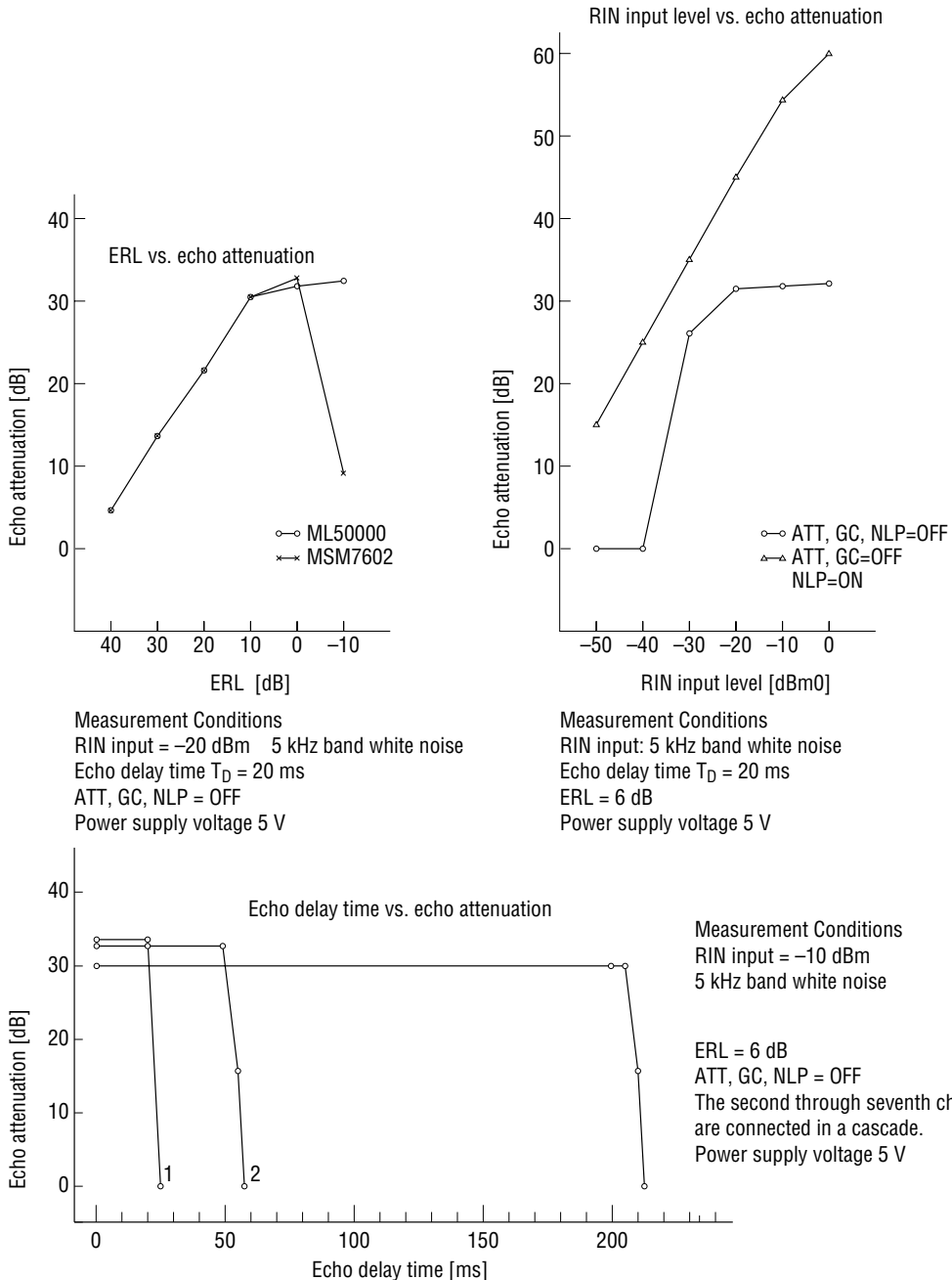

Measurement Conditions  
 RIN input = -20 dBm 5 kHz band white noise  
 Echo delay time  $T_D = 20$  ms  
 ATT, GC, NLP = OFF  
 Power supply voltage 5 V

Measurement Conditions  
 RIN input: 5 kHz band white noise  
 Echo delay time  $T_D = 20$  ms  
 ERL = 6 dB  
 Power supply voltage 5 V

Measurement Conditions  
 RIN input = -10 dBm  
 5 kHz band white noise  
 ERL = 6 dB  
 ATT, GC, NLP = OFF  
 The second through seventh chips  
 are connected in a cascade.  
 Power supply voltage 5 V

Note: The characteristics above are for the MSM7533 ( $V_{DD}$  5 V,  $\mu$ -law interface). The MSM7704 ( $V_{DD}$  3 V,  $\mu$ -law interface) provides the same characteristics without input and output levels. Refer to are PCM CODEC data sheet.

- MSM7533 (for both transmit and receive)  
 0 dBm0 = 0.85 Vrms = 0.8 dBm (600  $\Omega$ )
- MSM7704 (for transmit side)  
 0 dBm0 = 0.35 Vrms = -6.9 dBm (600  $\Omega$ )
- MSM7704 (for receive side)  
 0 dBm0 = 0.5 Vrms = -3.8 dBm (600  $\Omega$ )

Measurement System Block Diagram

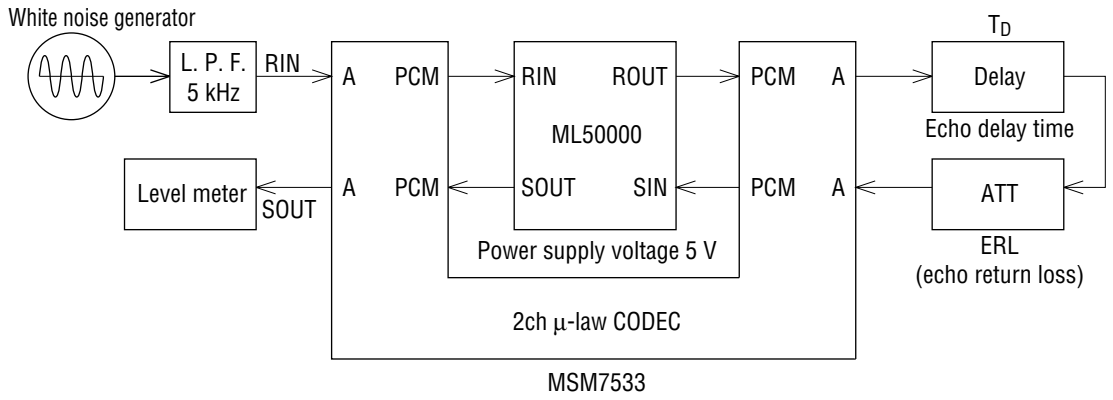

### APPLICATION CIRCUIT

#### Bidirectional Connection Example

Use the MSM7704-01GS-VK for PCM CODEC when V<sub>DD</sub> 3V.  
The MSM7533 and MSM7704 are pin compatible.

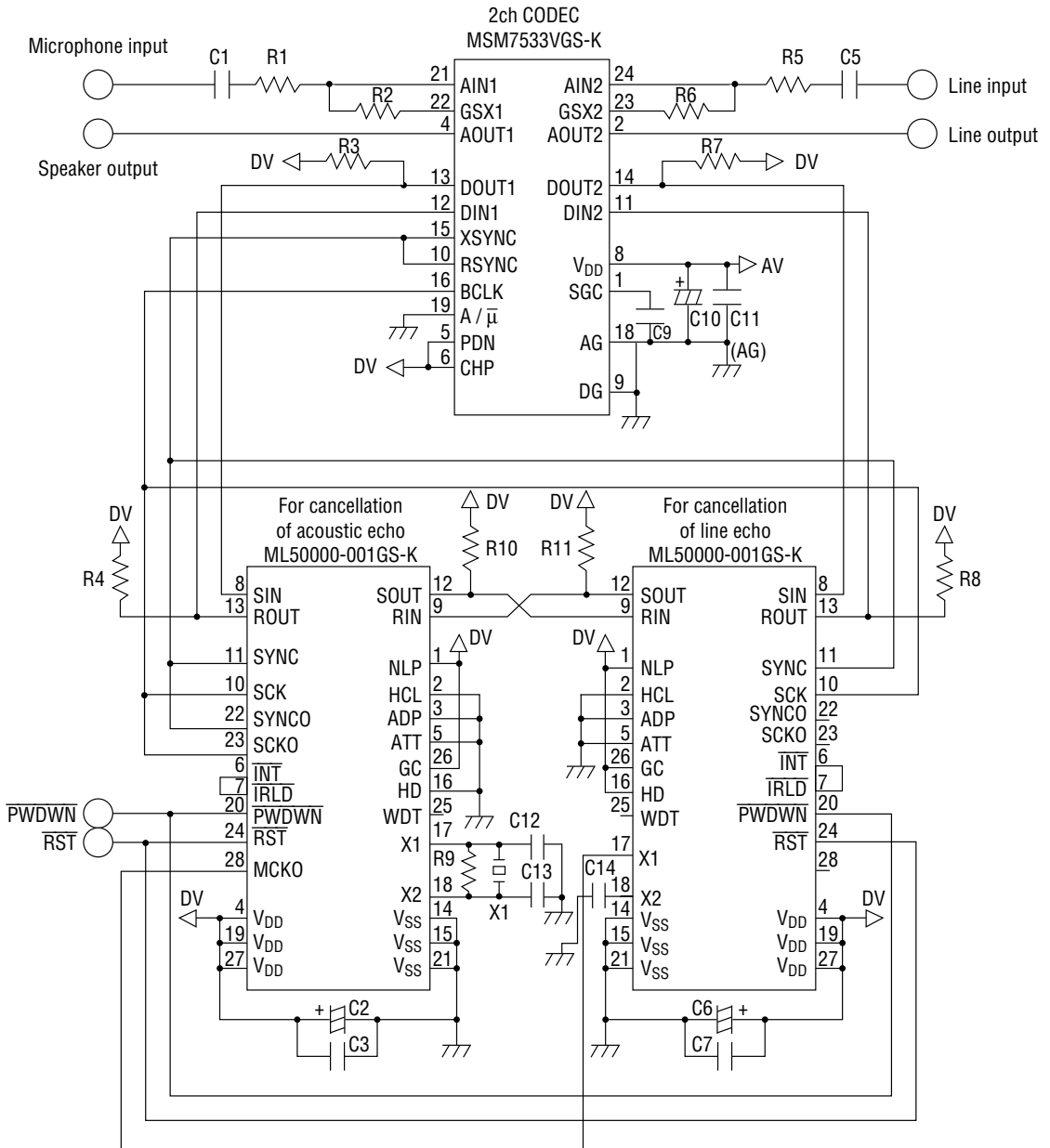

- |             |             |             |             |              |               |
|-------------|-------------|-------------|-------------|--------------|---------------|
| R1 = 20 kΩ  | C1 = 1 μF   | R5 = 20 kΩ  | C5 = 1 μF   | C9 = 0.1 μF  | R9 = 1 MΩ     |
| R2 = 20 kΩ  | C2 = 10 μF  | R6 = 20 kΩ  | C6 = 10 μF  | C10 = 10 μF  | C12 = 27 pF   |
| R3 = 2.2 kΩ | C3 = 0.1 μF | R7 = 2.2 kΩ | C7 = 0.1 μF | C11 = 0.1 μF | C13 = 27 pF   |
| R4 = 10 kΩ  | C4 = 0.1 μF | R8 = 10 kΩ  | C8 = 0.1 μF |              | X1 = 19.2 MHz |
| R10 = 10 kΩ |             | R11 = 10 kΩ |             |              | C14 = 5 pF    |

Cascade Connection Example

When  $V_{DD}$  is 3 V, use the MSM7566 for PCM CODEC.  
 The MSM7543 and MSM7566 are pin compatible.

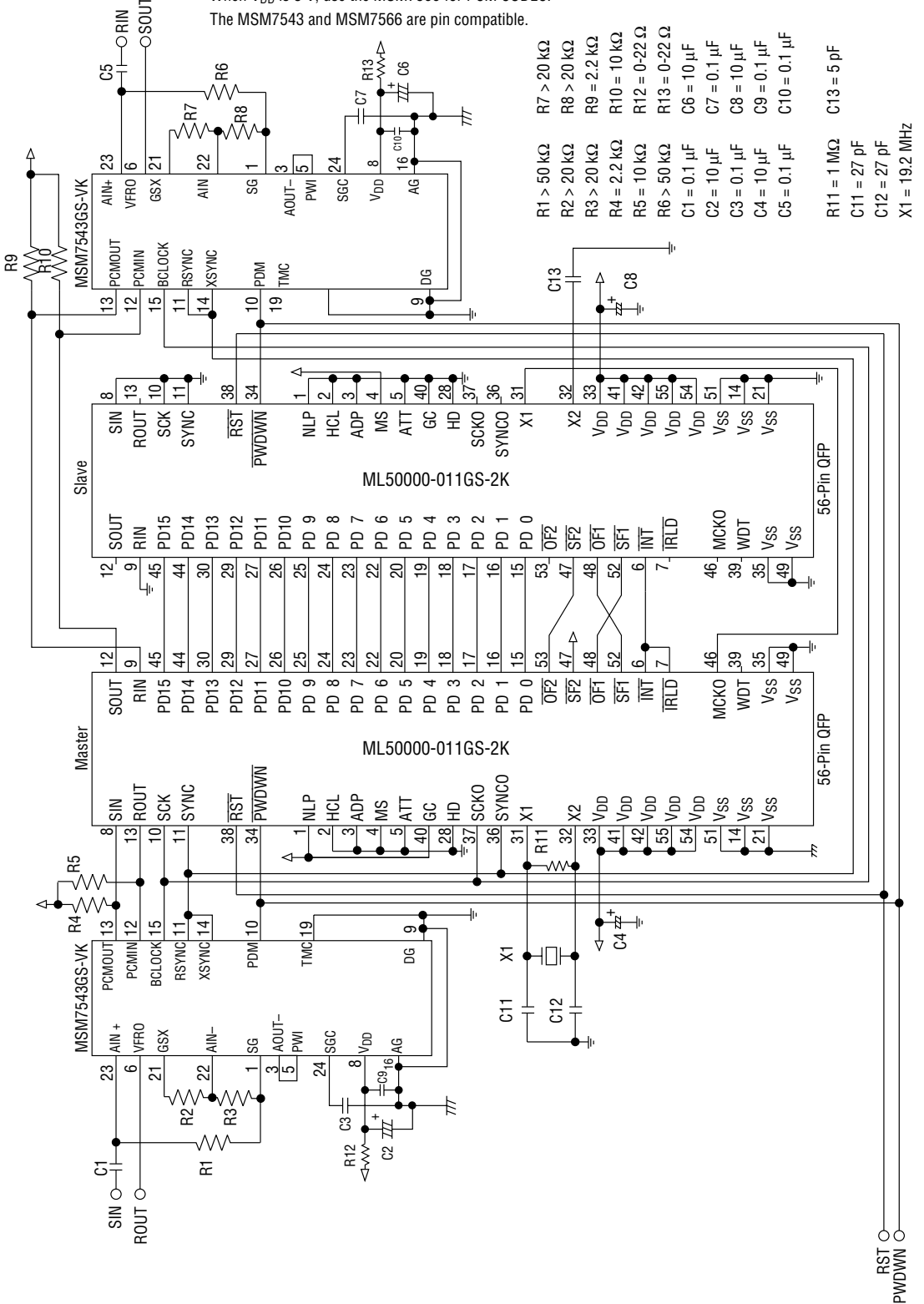

- R1 > 50 kΩ
- R2 > 20 kΩ
- R3 > 20 kΩ
- R4 = 2.2 kΩ
- R5 = 10 kΩ
- R6 > 50 kΩ
- R7 > 20 kΩ
- R8 > 20 kΩ
- R9 = 2.2 kΩ
- R10 = 10 kΩ
- R12 = 0-22 Ω
- R13 = 0-22 Ω
- C1 = 0.1 μF
- C2 = 10 μF
- C3 = 0.1 μF
- C4 = 10 μF
- C5 = 0.1 μF
- C6 = 10 μF
- C7 = 0.1 μF
- C8 = 10 μF
- C9 = 0.1 μF
- C10 = 0.1 μF
- R11 = 1 MΩ
- C11 = 27 pF
- C12 = 27 pF
- X1 = 19.2 MHz

## NOTES ON USE

1. Set echo return loss (ERL) to be attenuated. The echo can be eliminated even if the echo return loss is set to be amplified. This may cause an excessive input. Refer to the characteristics diagram for ERL vs. echo attenuation quantity.
2. Set the level of the analog input so that the PCM CODEC does not overflow.
3. The recommended input level is  $-10$  to  $-20$  dBm0. Refer to the characteristics diagram for the RIN input level vs. echo attenuation quantity.
4. Applying the tone signal to this echo canceler for long duration may decrease echo attenuation.  
When used with the HD pin "L" (howling detector ON), this echo canceler may operate faultily if, while a signal is input to the RIN pin, a tone signal with a higher level than the signal being input to RIN is input to the SIN pin.  
A signal should therefore be input either to the RIN pin or to the SIN pin. If, however, the tone signal is input to the SIN pin while a signal is input to the RIN pin, the ADP, HD, or HCL pin must be set to "H".
5. When turning the power ON, set the  $\overline{\text{PWDWN}}$  pin to "1" and input the basic clock simultaneously with power ON.  
If powering down immediately after power ON, be sure fast input 10 or more clocks of the basic clock.
6. After powering ON, be sure to reset.
7. After the power down mode is released (when the  $\overline{\text{PWDWN}}$  pin is changed to "H" from "L"), be sure to reset the device.
8. If this canceler is used to cancel acoustic echoes, an echo attenuation may be less than 30 dB.

**PACKAGE DIMENSIONS**

(Unit : mm)

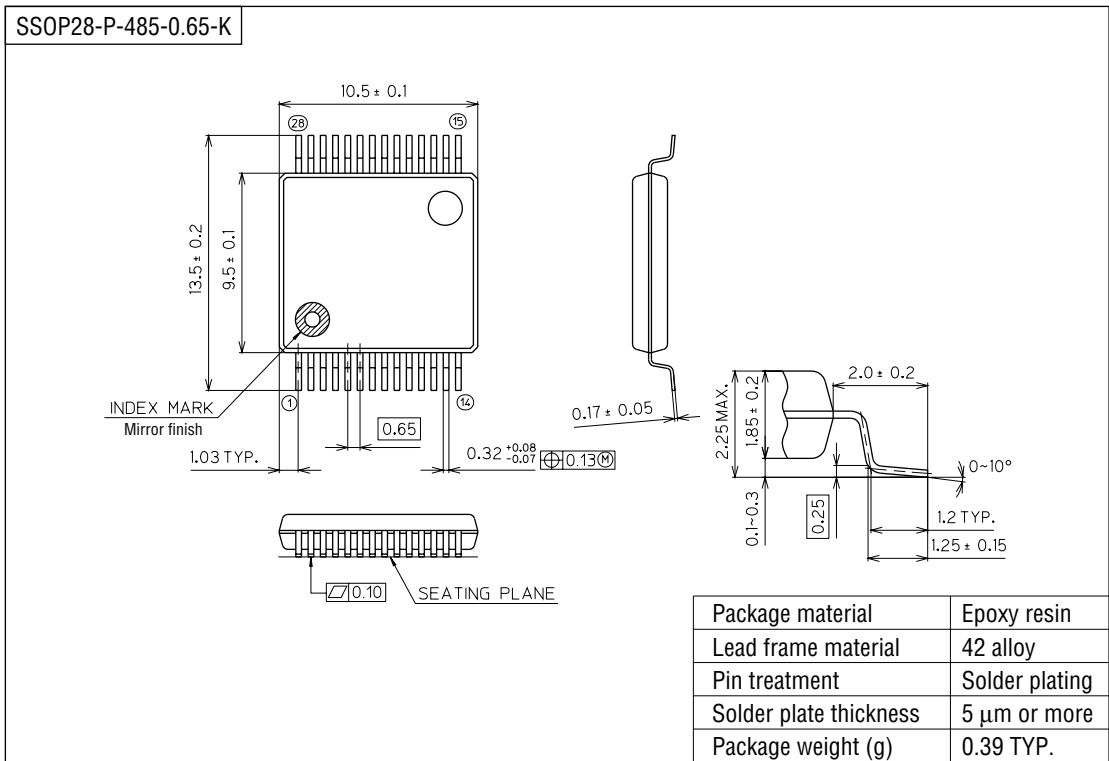

**Notes for Mounting the Surface Mount Type Package**

The SOP, QFP, TSOP, SOJ, QFJ (PLCC), SHP and BGA are surface mount type packages, which are very susceptible to heat in reflow mounting and humidity absorbed in storage. Therefore, before you perform reflow mounting, contact Oki's responsible sales person for the product name, package name, pin number, package code and desired mounting conditions (reflow method, temperature and times).

(Unit : mm)

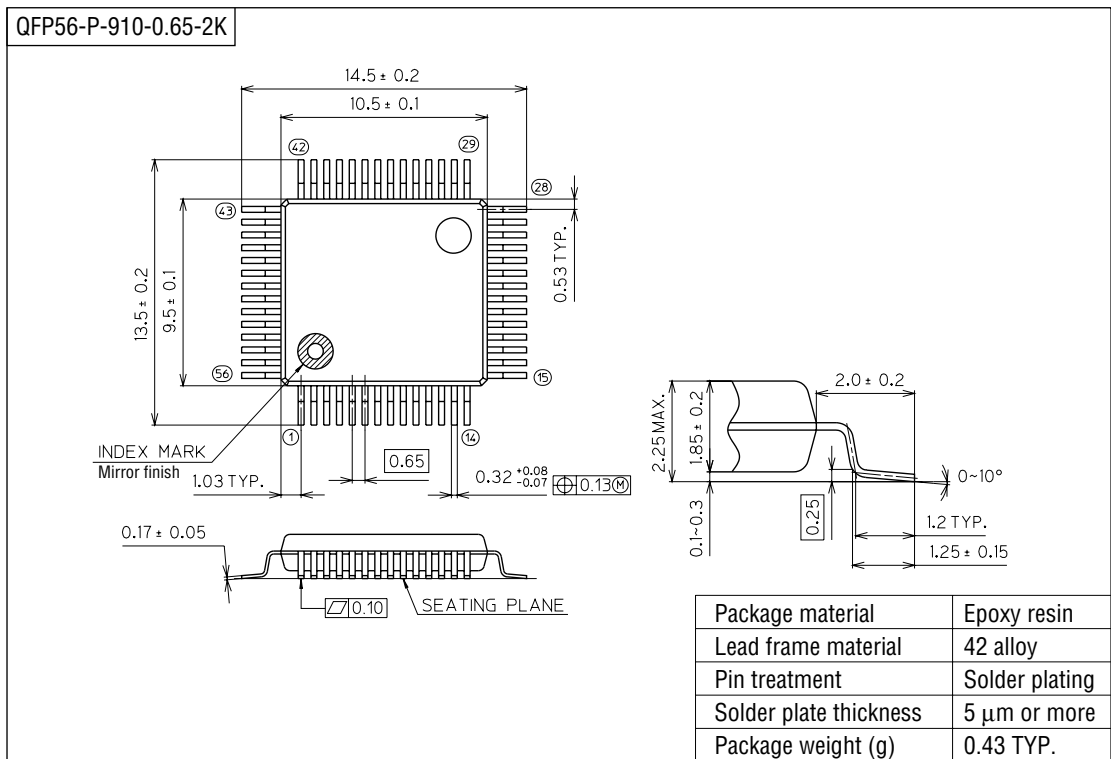

Notes for Mounting the Surface Mount Type Package

The SOP, QFP, TSOP, SOJ, QFJ (PLCC), SHP and BGA are surface mount type packages, which are very susceptible to heat in reflow mounting and humidity absorbed in storage. Therefore, before you perform reflow mounting, contact Oki's responsible sales person for the product name, package name, pin number, package code and desired mounting conditions (reflow method, temperature and times).