

Description

Description

The M16C/62M group of single-chip microcomputers are built using the high-performance silicon gate CMOS process using a M16C/60 Series CPU core and are packaged in a 100-pin plastic molded QFP. These single-chip microcomputers operate using sophisticated instructions featuring a high level of instruction efficiency. With 1M bytes of address space, low voltage (2.2V to 3.6V), they are capable of executing instructions at high speed. They also feature a built-in multiplier and DMAC, making them ideal for controlling office, communications, industrial equipment, and other high-speed processing applications.

The M16C/62M group includes a wide range of products with different internal memory types and sizes and various package types.

Features

- Memory capacity ROM (See Figure 1.1.4. ROM Expansion)
RAM 10K to 20K bytes
- Shortest instruction execution time 100ns (f(XIN)=10MHz, VCC=2.7V to 3.6V)
142.9ns (f(XIN)=7MHz, VCC=2.2V to 3.6V with software one-wait)
- Supply voltage 2.7V to 3.6V (f(XIN)=10MHz, without software wait)
2.4V to 2.7V (f(XIN)=7MHz, without software wait)
2.2V to 2.4V (f(XIN)=7MHz with software one-wait)
- Low power consumption 28.5mW (VCC = 3V, f(XIN)=10MHz, without software wait)
- Interrupts 25 internal and 8 external interrupt sources, 4 software
interrupt sources; 7 levels (including key input interrupt)
- Multifunction 16-bit timer 5 output timers + 6 input timers
- Serial I/O 5 channels
(3 for UART or clock synchronous, 2 for clock synchronous)
- DMAC 2 channels (trigger: 24 sources)
- A-D converter 10 bits X 8 channels (Expandable up to 10 channels)
- D-A converter 8 bits X 2 channels
- CRC calculation circuit 1 circuit
- Watchdog timer 1 line
- Programmable I/O 87 lines
- Input port 1 line (P85 shared with $\overline{\text{NMI}}$ pin)
- Memory expansion Available (to a maximum of 1M bytes)
- Chip select output 4 lines
- Clock generating circuit 2 built-in clock generation circuits
(built-in feedback resistor, and external ceramic or quartz oscillator)

Applications

Audio, cameras, office equipment, communications equipment, portable equipment

Description

Pin Configuration

Figures 1.1.1 and 1.1.2 show the pin configurations (top view).

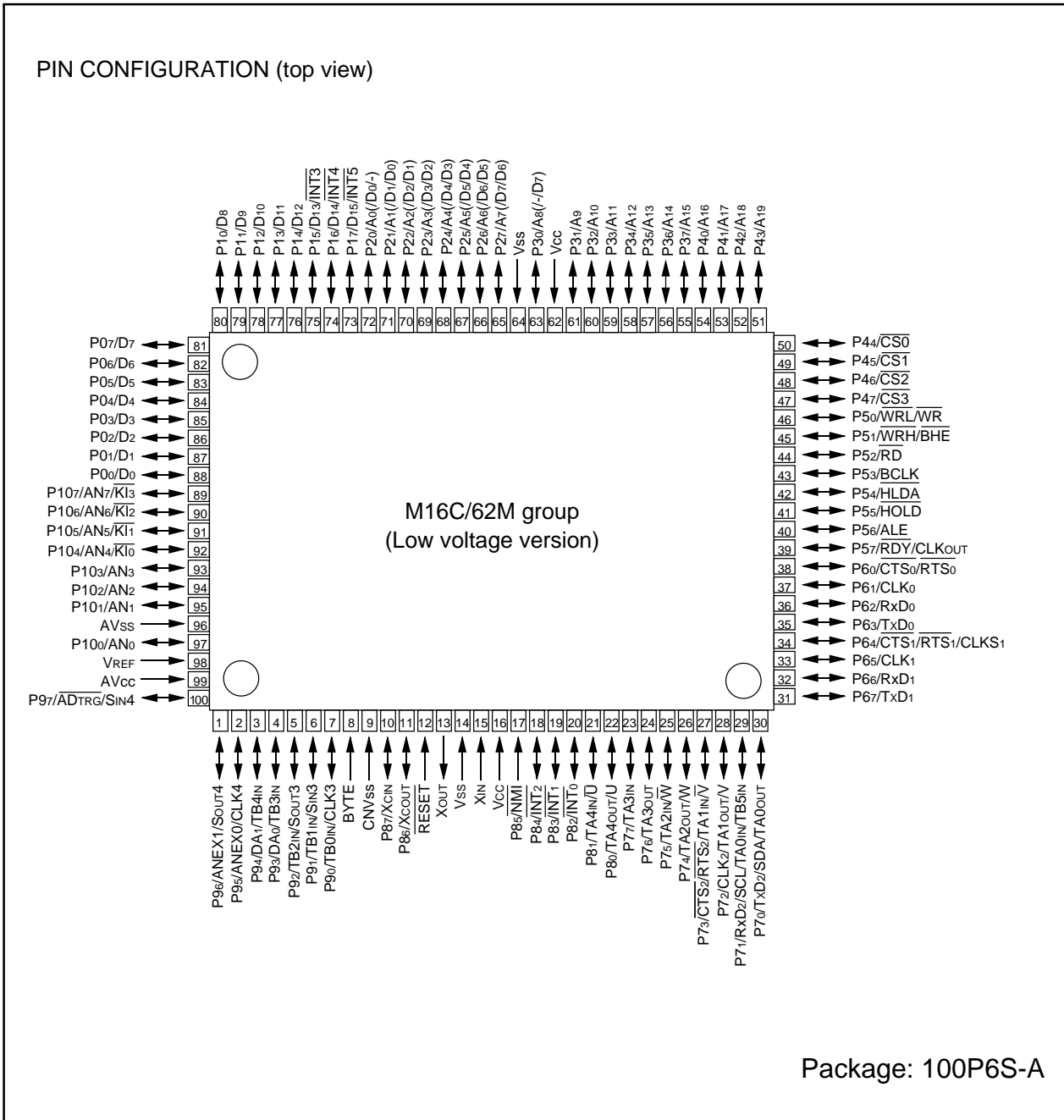

Figure 1.1.1. Pin configuration (top view)

Description

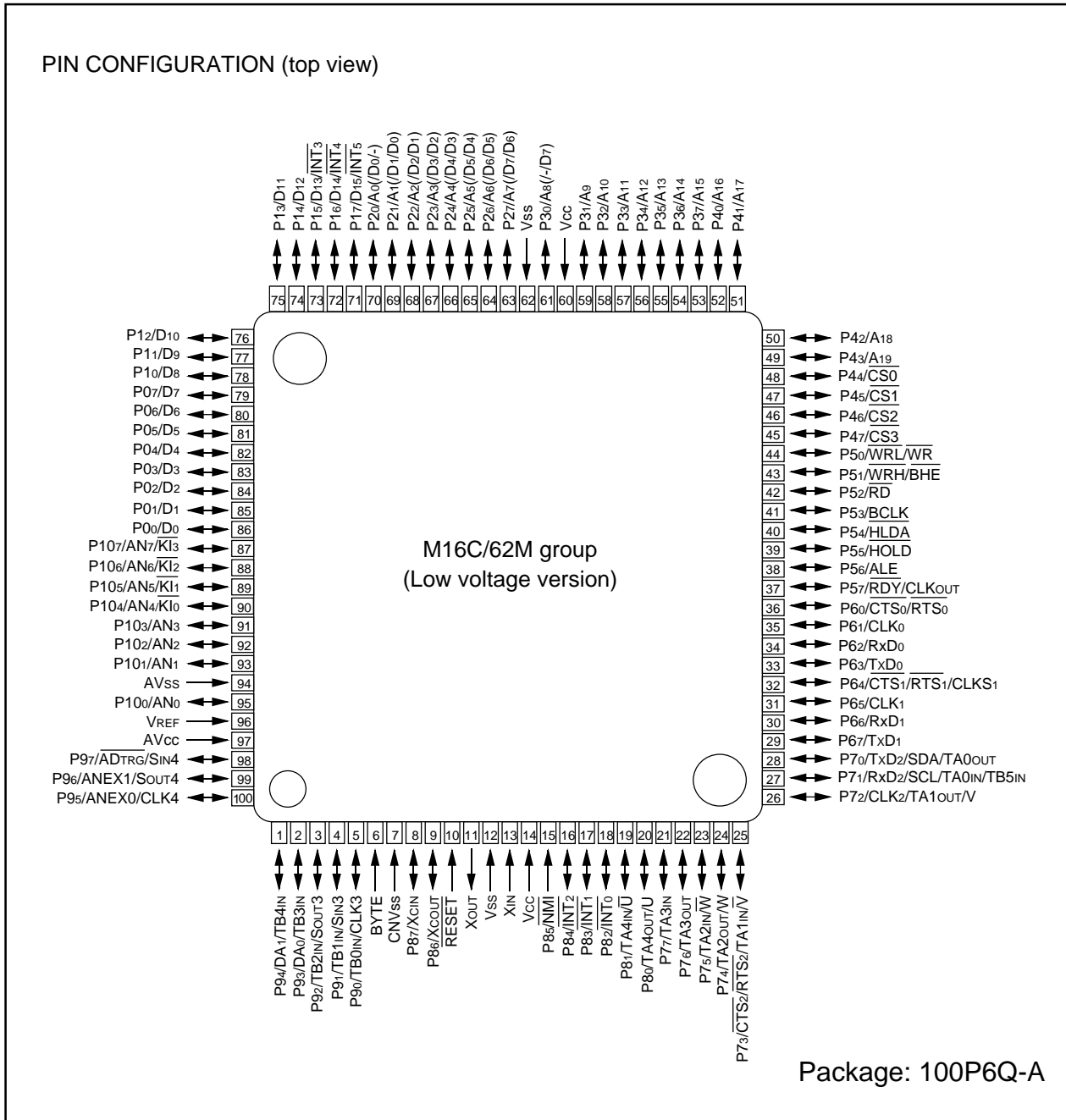

Figure 1.1.2. Pin configuration (top view)

Description

Block Diagram

Figure 1.1.3 is a block diagram of the M16C/62M group.

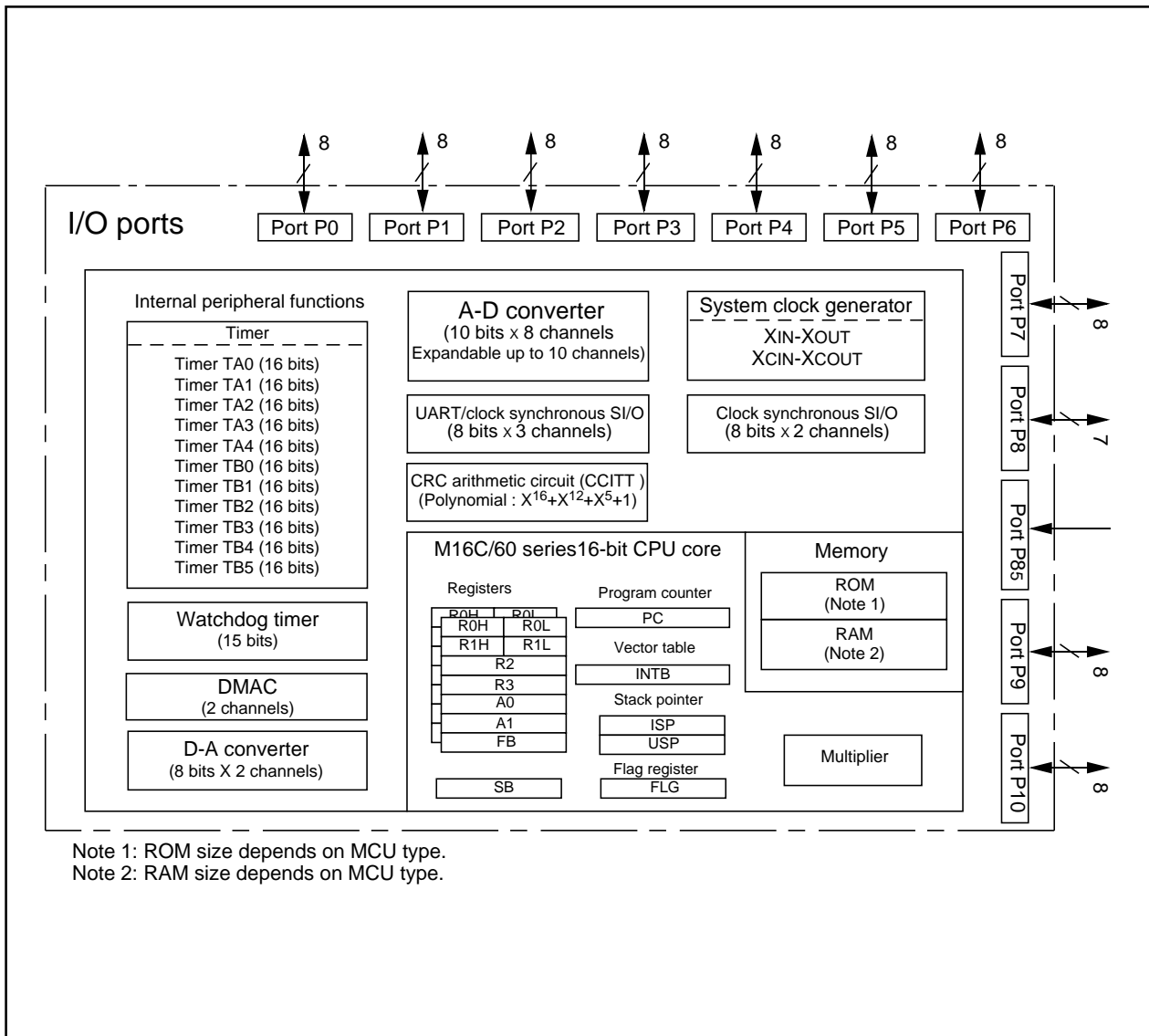

Figure 1.1.3. Block diagram of M16C/62M group

Description

Performance Outline

Table 1.1.1 is a performance outline of M16C/62M group.

Table 1.1.1. Performance outline of M16C/62M group

Item		Performance
Number of basic instructions		91 instructions
Shortest instruction execution time		100ns($f(X_{IN})=10\text{MHz}$, $V_{CC}=2.7\text{V}$ to 3.6V) 142.9ns ($f(X_{IN})=7\text{MHz}$, $V_{CC}=2.2\text{V}$ to 3.6V with software one-wait)
Memory capacity	ROM	(See the figure 1.1.4. ROM Expansion)
	RAM	10K to 20K bytes
I/O port	P0 to P10 (except P85)	8 bits x 10, 7 bits x 1
Input port	P85	1 bit x 1
Multifunction timer	TA0, TA1, TA2, TA3, TA4	16 bits x 5
	TB0, TB1, TB2, TB3, TB4, TB5	16 bits x 6
Serial I/O	UART0, UART1, UART2	(UART or clock synchronous) x 3
	SI/O3, SI/O4	(Clock synchronous) x 2
A-D converter		10 bits x (8 + 2) channels
D-A converter		8 bits x 2
DMAC		2 channels (trigger: 24 sources)
CRC calculation circuit		CRC-CCITT
Watchdog timer		15 bits x 1 (with prescaler)
Interrupt		25 internal and 8 external sources, 4 software sources, 7 levels
Clock generating circuit		2 built-in clock generation circuits (built-in feedback resistor, and external ceramic or quartz oscillator)
Supply voltage		2.7V to 3.6V ($f(X_{IN})=10\text{MHz}$, without software wait) 2.4V to 2.7V ($f(X_{IN})=7\text{MHz}$, without software wait) 2.2V to 2.4V ($f(X_{IN})=7\text{MHz}$ with software one-wait)
Power consumption		28.5mW ($f(X_{IN})=10\text{MHz}$, $V_{CC}=3\text{V}$ without software wait)
I/O characteristics	I/O withstand voltage	3V
	Output current	1mA
Memory expansion		Available (to a maximum of 1M bytes)
Device configuration		CMOS high performance silicon gate
Package		100-pin plastic mold QFP

Description

Mitsubishi plans to release the following products in the M16C/62M group:

- (1) Support for mask ROM version and Flash memory version
- (2) ROM capacity
- (3) Package
 - 100P6S-A : Plastic molded QFP (mask ROM and flash memory versions)
 - 100P6Q-A : Plastic molded QFP (mask ROM and flash memory versions)

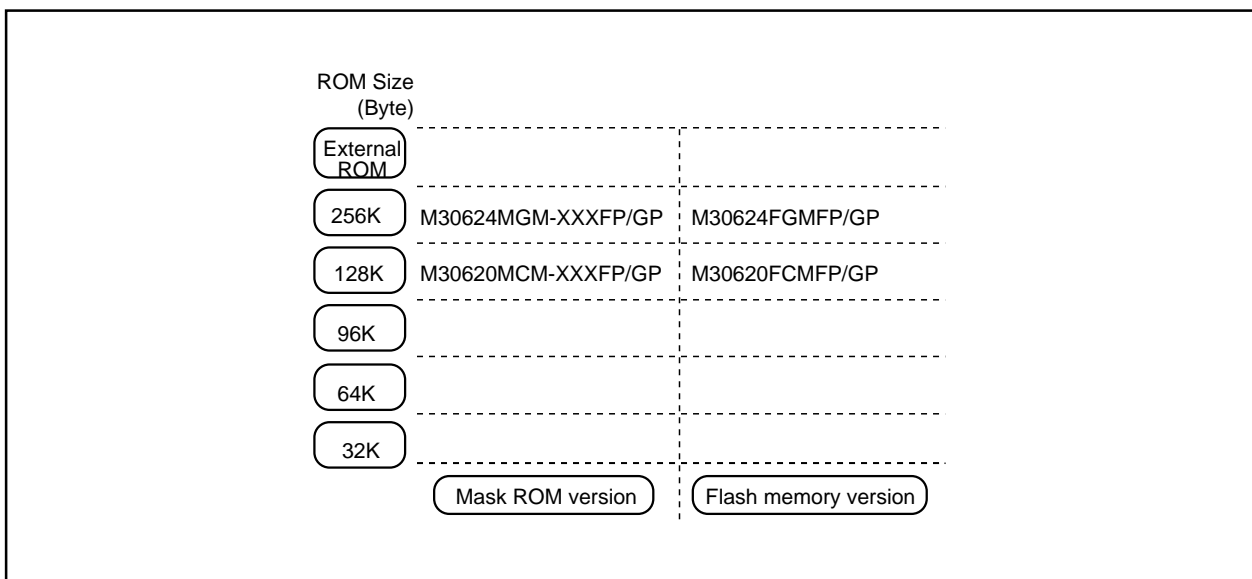

Figure 1.1.4. ROM expansion

The M16C/62M group products currently supported are listed in Table 1.1.2.

Table 1.1.2. M16C/62M group

June, 2001

Type No	ROM capacity	RAM capacity	Package type	Remarks
M30620MCM-XXXFP	128K byte	10K byte	100P6S-A	mask ROM version
M30620MCM-XXXGP			100P6Q-A	
M30624MGM-XXXFP	256K byte	20K byte	100P6S-A	
M30624MGM-XXXGP			100P6Q-A	
M30620FCMFP	128K byte	10K byte	100P6S-A	Flash memory 3V version
M30620FCMGP			100P6Q-A	
M30624FGMFP	256K byte	20K byte	100P6S-A	
M30624FGMGP			100P6Q-A	

Description

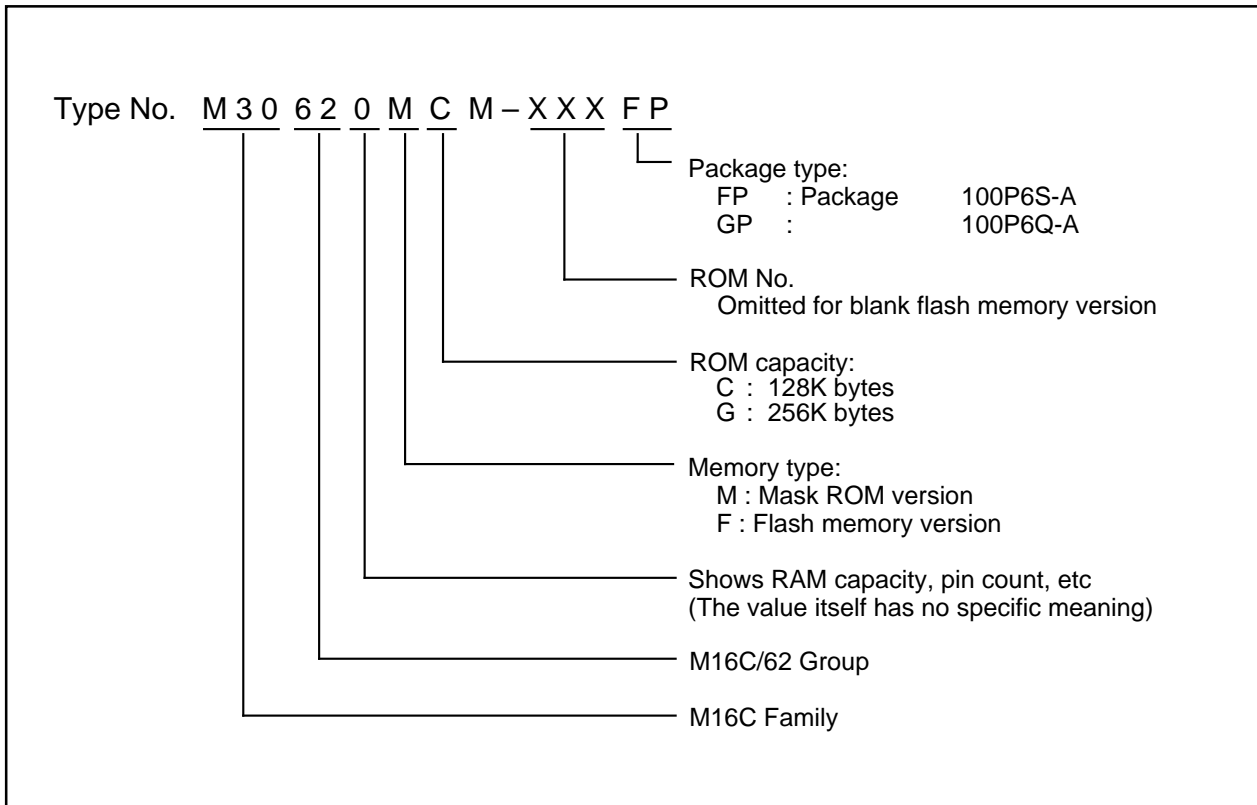

Figure 1.1.5. Type No., memory size, and package

Table 1.26.1. Absolute maximum ratings

Symbol	Parameter		Condition	Rated value	Unit
V _{cc}	Supply voltage		V _{cc} =AV _{cc}	- 0.3 to 4.6	V
AV _{cc}	Analog supply voltage		V _{cc} =AV _{cc}	- 0.3 to 4.6	V
V _I	Input voltage	RESET, CNV _{ss} , BYTE, P0 ₀ to P0 ₇ , P1 ₀ to P1 ₇ , P2 ₀ to P2 ₇ , P3 ₀ to P3 ₇ , P4 ₀ to P4 ₇ , P5 ₀ to P5 ₇ , P6 ₀ to P6 ₇ , P7 ₂ to P7 ₇ , P8 ₀ to P8 ₇ , P9 ₀ to P9 ₇ , P10 ₀ to P10 ₇ , VREF, X _{IN}		- 0.3 to V _{cc} + 0.3	V
		P7 ₀ , P7 ₁		- 0.3 to 4.6	V
V _O	Output voltage	P0 ₀ to P0 ₇ , P1 ₀ to P1 ₇ , P2 ₀ to P2 ₇ , P3 ₀ to P3 ₇ , P4 ₀ to P4 ₇ , P5 ₀ to P5 ₇ , P6 ₀ to P6 ₇ , P7 ₂ to P7 ₇ , P8 ₀ to P8 ₄ , P8 ₆ , P8 ₇ , P9 ₀ to P9 ₇ , P10 ₀ to P10 ₇ , X _{OUT}		- 0.3 to V _{cc} + 0.3	V
		P7 ₀ , P7 ₁		- 0.3 to 4.6	V
P _d	Power dissipation		T _{opr} =25 °C	300	mW
T _{opr}	Operating ambient temperature			- 20 to 85 / -40 to 85 (Note)	°C
T _{stg}	Storage temperature			- 65 to 150	°C

Note : Specify a product of -40°C to 85°C to use it.

Table 1.26.2. Recommended operating conditions (referenced to V_{CC} = 2.2V to 3.6V at Topr = -20°C to 85°C / -40°C to 85°C (Note 3) unless otherwise specified)

Symbol	Parameter	Standard			Unit	
		Min.	Typ.	Max.		
V _{CC}	Supply voltage	2.2	3.0	3.6	V	
AV _{CC}	Analog supply voltage		V _{CC}		V	
V _{SS}	Supply voltage		0		V	
AV _{SS}	Analog supply voltage		0		V	
V _{IH}	HIGH input voltage P31 to P37, P40 to P47, P50 to P57, P60 to P67, P72 to P77, P80 to P87, P90 to P97, P100 to P107, X _{IN} , RESET, CNV _{SS} , BYTE P70, P71	P31 to P37, P40 to P47, P50 to P57, P60 to P67, P72 to P77, P80 to P87, P90 to P97, P100 to P107, X _{IN} , RESET, CNV _{SS} , BYTE	0.8V _{CC}	V _{CC}	V	
		P70, P71	0.8V _{CC}	4.6	V	
		P00 to P07, P10 to P17, P20 to P27, P30 (during single-chip mode)	0.8V _{CC}	V _{CC}	V	
		P00 to P07, P10 to P17, P20 to P27, P30 (data input function during memory expansion and microprocessor modes)	0.5V _{CC}	V _{CC}	V	
V _{IL}	LOW input voltage P31 to P37, P40 to P47, P50 to P57, P60 to P67, P70 to P77, P80 to P87, P90 to P97, P100 to P107, X _{IN} , RESET, CNV _{SS} , BYTE P00 to P07, P10 to P17, P20 to P27, P30 (during single-chip mode)	P31 to P37, P40 to P47, P50 to P57, P60 to P67, P70 to P77, P80 to P87, P90 to P97, P100 to P107, X _{IN} , RESET, CNV _{SS} , BYTE	0	0.2V _{CC}	V	
		P00 to P07, P10 to P17, P20 to P27, P30 (during single-chip mode)	0	0.2V _{CC}	V	
		P00 to P07, P10 to P17, P20 to P27, P30 (data input function during memory expansion and microprocessor modes)	0	0.16V _{CC}	V	
I _{OH} (peak)	HIGH peak output current P00 to P07, P10 to P17, P20 to P27, P30 to P37, P40 to P47, P50 to P57, P60 to P67, P72 to P77, P80 to P84, P86, P87, P90 to P97, P100 to P107			- 10.0	mA	
I _{OH} (avg)	HIGH average output current P00 to P07, P10 to P17, P20 to P27, P30 to P37, P40 to P47, P50 to P57, P60 to P67, P72 to P77, P80 to P84, P86, P87, P90 to P97, P100 to P107			- 5.0	mA	
I _{OL} (peak)	LOW peak output current P00 to P07, P10 to P17, P20 to P27, P30 to P37, P40 to P47, P50 to P57, P60 to P67, P70 to P77, P80 to P84, P86, P87, P90 to P97, P100 to P107			10.0	mA	
I _{OL} (avg)	LOW average output current P00 to P07, P10 to P17, P20 to P27, P30 to P37, P40 to P47, P50 to P57, P60 to P67, P70 to P77, P80 to P84, P86, P87, P90 to P97, P100 to P107			5.0	mA	
f (X _{IN})	Main clock input oscillation frequency	No wait	V _{CC} =2.7V to 3.6V	0	10	MHz
			V _{CC} =2.4V to 2.7V	0	10 X V _{CC} - 17	MHz
		with wait	V _{CC} =2.2V to 2.4V	0	17.5 X V _{CC} - 35	MHz
			V _{CC} =2.7V to 3.6V	0	10	MHz
			V _{CC} =2.2V to 2.7V	0	6 X V _{CC} - 6.2	MHz
f (X _{CIN})	Subclock oscillation frequency		32.768	50	kHz	

Note 1: The mean output current is the mean value within 100ms.

Note 2: The total I_{OL} (peak) for ports P0, P1, P2, P86, P87, P9, and P10 must be 80mA max. The total I_{OH} (peak) for ports P0, P1, P2, P86, P87, P9, and P10 must be 80mA max. The total I_{OL} (peak) for ports P3, P4, P5, P6, P7, and P80 to P84 must be 80mA max. The total I_{OH} (peak) for ports P3, P4, P5, P6, P72 to P77, and P80 to P84 must be 80mA max.

Note 3: Specify a product of -40°C to 85°C to use it.

Note 4: Relationship between main clock oscillation frequency and supply voltage.

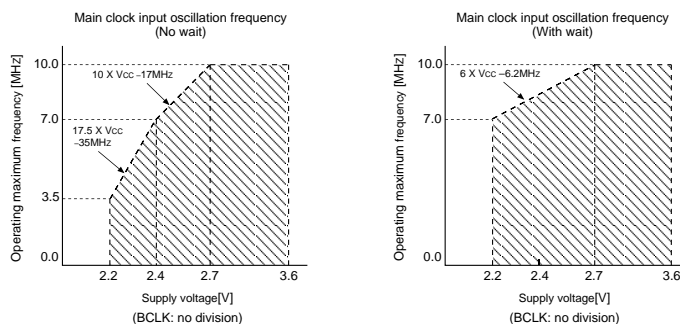

Flash memory version program voltage and read operation voltage characteristics

Flash program voltage	Flash read operation voltage
V _{CC} =2.7V to 3.6V	V _{CC} =2.4V to 3.6V
V _{CC} =2.7V to 3.4V	V _{CC} =2.2V to 2.4V

Note 5: Execute case without wait, program / erase of flash memory by V_{CC}=2.7V to 3.6V and f(BCLK) ≤ 6.25 MHz. Execute case with wait, program / erase of flash memory by V_{CC}=2.7V to 3.6V and f(BCLK) ≤ 10.0 MHz.

Table 1.26.3. Electrical characteristics (referenced to $V_{CC} = 2.7V$ to $3.6V$, $V_{SS} = 0V$ at $T_{opr} = -20^{\circ}C$ to $85^{\circ}C$ / $-40^{\circ}C$ to $85^{\circ}C$ (Note 1), $f(X_{IN}) = 10MHz$ without wait unless otherwise specified)

Symbol	Parameter		Measuring condition	Standard			Unit	
				Min	Typ.	Max.		
V_{OH}	HIGH output voltage	P00 to P07, P10 to P17, P20 to P27, P30 to P37, P40 to P47, P50 to P57, P60 to P67, P72 to P77, P80 to P84, P86, P87, P90 to P97, P100 to P107	$I_{OH} = -1mA$	2.5			V	
V_{OH}	HIGH output voltage	X_{OUT}	HIGHPOWER	$I_{OH} = -0.1mA$	2.5		V	
			LOWPOWER	$I_{OH} = -50\mu A$	2.5			
	HIGH output voltage	X_{COUT}	HIGHPOWER	With no load applied		3.0	V	
			LOWPOWER	With no load applied		1.6		
V_{OL}	LOW output voltage	P00 to P07, P10 to P17, P20 to P27, P30 to P37, P40 to P47, P50 to P57, P60 to P67, P70 to P77, P80 to P84, P86, P87, P90 to P97, P100 to P107	$I_{OL} = 1mA$			0.5	V	
V_{OL}	LOW output voltage	X_{OUT}	HIGHPOWER	$I_{OL} = 0.1mA$		0.5	V	
			LOWPOWER	$I_{OL} = 50\mu A$		0.5		
	LOW output voltage	X_{COUT}	HIGHPOWER	With no load applied		0	V	
			LOWPOWER	With no load applied		0		
$V_{T+} - V_{T-}$	Hysteresis	HOLD, RDY, TA0IN to TA4IN, TB0IN to TB5IN, INT0 to INT5, NMI, ADTRG, CTS0 to CTS2, SCL, SDA, CLK0 to CLK4, TA2OUT to TA4OUT, KI0 to KI3, RxD0 to RxD2, SIN3, SIN4		0.2		0.8	V	
$V_{T+} - V_{T-}$	Hysteresis	RESET		0.2		1.8	V	
I_{IH}	HIGH input current	P00 to P07, P10 to P17, P20 to P27, P30 to P37, P40 to P47, P50 to P57, P60 to P67, P70 to P77, P80 to P87, P90 to P97, P100 to P107, XIN, RESET, CNVss, BYTE	$V_I = 3V$			4.0	μA	
I_{IL}	LOW input current	P00 to P07, P10 to P17, P20 to P27, P30 to P37, P40 to P47, P50 to P57, P60 to P67, P70 to P77, P80 to P87, P90 to P97, P100 to P107, XIN, RESET, CNVss, BYTE	$V_I = 0V$			-4.0	μA	
RPULLUP	Pull-up resistance	P00 to P07, P10 to P17, P20 to P27, P30 to P37, P40 to P47, P50 to P57, P60 to P67, P72 to P77, P80 to P84, P86, P87, P90 to P97, P100 to P107	$V_I = 0V$	20	75	330	k Ω	
RfXIN	Feedback resistance	X_{IN}			3.0		M Ω	
RfXCIN	Feedback resistance	X_{CIN}			10.0		M Ω	
VRAM	RAM retention voltage		When clock is stopped	2.0			V	
I_{CC}	Power supply current	In single-chip mode, the output pins are open and other pins are Vss	Mask ROM version	$f(X_{IN}) = 10MHz$ Square wave, no division		9.5	21.25	mA
			Flash memory 3V version	$f(X_{IN}) = 10MHz$ Square wave, no division		12.0	21.25	mA
			Mask ROM version, flash memory 3V version	$f(X_{CIN}) = 32kHz$ Square wave		45.0		μA
			Flash memory 3V version program	$f(X_{IN}) = 10MHz$ Square wave, division by 2		14.0		mA
			Flash memory 3V version erase	$f(X_{IN}) = 10MHz$ Square wave, division by 2		17.0		mA
			Mask ROM version, flash memory 3V version	$f(X_{CIN}) = 32kHz$ When a WAIT instruction is executed. Oscillation capacity High (Note 2)		2.8		μA
				$f(X_{CIN}) = 32kHz$ When a WAIT instruction is executed. Oscillation capacity Low (Note 2)		0.9		μA
			When clock is stopped	$T_{opr} = 25^{\circ}C$			1.0	μA
When clock is stopped	$T_{opr} = 85^{\circ}C$			20.0				

Note 1: Specify a product of $-40^{\circ}C$ to $85^{\circ}C$ to use it.

Note 2: With one timer operated using fc32.

Electrical characteristics

Table 1.26.4. A-D conversion characteristics (referenced to $V_{CC} = AV_{CC} = V_{REF} = 2.4V$ to $3.6V$, $V_{SS} = AV_{SS} = 0V$, at $T_{opr} = -20^{\circ}C$ to $85^{\circ}C$ / $-40^{\circ}C$ to $85^{\circ}C$ (Note 2), $f(X_{IN})=10MHz$ unless otherwise specified)

Symbol	Parameter		Measuring condition	Standard			Unit
				Min.	Typ.	Max	
–	Resolution		$V_{REF} = V_{CC}$			10	Bits
–	Absolute accuracy	Sample & hold function not available (8 bit)	$V_{REF} = V_{CC} = 3V$, $f_{AD} = f_{AD}/2$			± 2	LSB
R_{LADDER}	Ladder resistance		$V_{REF} = V_{CC}$	10		40	k Ω
t_{CONV}	Conversion time(8bit)			9.8			μs
V_{REF}	Reference voltage			2.4		V_{CC}	V
V_{IA}	Analog input voltage			0		V_{REF}	V

Note 1: Connect AVCC pin to Vcc pin and apply the same electric potential.

Note 2: Specify a product of $-40^{\circ}C$ to $85^{\circ}C$ to use it.

Table 1.26.5. D-A conversion characteristics (referenced to $V_{CC} = 2.4V$ to $3.6V$, $V_{SS} = AV_{SS} = 0V$, $V_{REF} = 3V$, at $T_{opr} = -20^{\circ}C$ to $85^{\circ}C$ / $-40^{\circ}C$ to $85^{\circ}C$ (Note 2), $f(X_{IN})=10MHz$ unless otherwise specified)

Symbol	Parameter		Measuring condition	Standard			Unit
				Min.	Typ.	Max	
–	Resolution					8	Bits
–	Absolute accuracy					1.0	%
t_{su}	Setup time					3	μs
R_o	Output resistance			4	10	20	k Ω
I_{VREF}	Reference power supply input current		(Note1)			1.0	mA

Note 1: This applies when using one D-A converter, with the D-A register for the unused D-A converter set to "0016". The A-D converter's ladder resistance is not included.

Also, when D-A register contents are not "0016", the current I_{VREF} always flows even though V_{ref} may have been set to be "unconnected" by the A-D control register.

Note 2: Specify a product of $-40^{\circ}C$ to $85^{\circ}C$ to use it.

Table 1.26.6. Flash memory version electrical characteristics (referenced to $V_{CC} = 2.7V$ to $3.6V$, at $T_{opr} = 0^{\circ}C$ to $60^{\circ}C$ unless otherwise specified)

Parameter	Standard			Unit
	Min.	Typ.	Max	
Page program time		6	120	ms
Block erase time		50	600	ms
Erase all unlocked blocks time		50 X n (Note)	600 X n (Note)	ms
Lock bit program time		6	120	ms

Note : n denotes the number of block erases.

Table 1.26.7. Flash memory version program voltage and read operation voltage characteristics ($T_{opr} = 0^{\circ}C$ to $60^{\circ}C$)

Flash program voltage	Flash read operation voltage
$V_{CC} = 2.7V$ to $3.6V$	$V_{CC} = 2.4V$ to $3.6V$
$V_{CC} = 2.7V$ to $3.4V$	$V_{CC} = 2.2V$ to $2.4V$

Timing

Timing requirements

(referenced to $V_{CC} = 3V$, $V_{SS} = 0V$, at $T_{opr} = -20^{\circ}C$ to $85^{\circ}C$ / $-40^{\circ}C$ to $85^{\circ}C$ (*) unless otherwise specified)

* : Specify a product of $-40^{\circ}C$ to $85^{\circ}C$ to use it.

Table 1.26.8. External clock input

Symbol	Parameter	Standard		Unit
		Min.	Max.	
t_c	External clock input cycle time	100		ns
$t_{w(H)}$	External clock input HIGH pulse width	40		ns
$t_{w(L)}$	External clock input LOW pulse width	40		ns
t_r	External clock rise time		18	ns
t_f	External clock fall time		18	ns

Table 1.26.9. Memory expansion and microprocessor modes

Symbol	Parameter	Standard		Unit
		Min.	Max.	
$t_{ac1(RD-DB)}$	Data input access time (no wait)		(Note)	ns
$t_{ac2(RD-DB)}$	Data input access time (with wait)		(Note)	ns
$t_{ac3(RD-DB)}$	Data input access time (when accessing multiplex bus area)		(Note)	ns
$t_{su(DB-RD)}$	Data input setup time	80		ns
$t_{su(RDY-BCLK)}$	RDY input setup time	60		ns
$t_{su(HOLD-BCLK)}$	HOLD input setup time	80		ns
$t_h(RD-DB)$	Data input hold time	0		ns
$t_h(BCLK-RDY)$	RDY input hold time	0		ns
$t_h(BCLK-HOLD)$	HOLD input hold time	0		ns
$t_d(BCLK-HLDA)$	HLDA output delay time		100	ns

Note: Calculated according to the BCLK frequency as follows:

$$t_{ac1(RD-DB)} = \frac{10^9}{f(BCLK) \times 2} - 90 \quad [ns]$$

$$t_{ac2(RD-DB)} = \frac{3 \times 10^9}{f(BCLK) \times 2} - 90 \quad [ns]$$

$$t_{ac3(RD-DB)} = \frac{3 \times 10^9}{f(BCLK) \times 2} - 90 \quad [ns]$$

Timing

Timing requirements(referenced to $V_{CC} = 3V$, $V_{SS} = 0V$, at $T_{opr} = -20^{\circ}C$ to $85^{\circ}C$ / $-40^{\circ}C$ to $85^{\circ}C$ (*) unless otherwise specified)* : Specify a product of $-40^{\circ}C$ to $85^{\circ}C$ to use it.**Table 1.26.10. Timer A input (counter input in event counter mode)**

Symbol	Parameter	Standard		Unit
		Min.	Max.	
$t_{c(TA)}$	TAiIn input cycle time	150		ns
$t_{w(TAH)}$	TAiIn input HIGH pulse width	60		ns
$t_{w(TAL)}$	TAiIn input LOW pulse width	60		ns

Table 1.26.11. Timer A input (gating input in timer mode)

Symbol	Parameter	Standard		Unit
		Min.	Max.	
$t_{c(TA)}$	TAiIn input cycle time	600		ns
$t_{w(TAH)}$	TAiIn input HIGH pulse width	300		ns
$t_{w(TAL)}$	TAiIn input LOW pulse width	300		ns

Table 1.26.12. Timer A input (external trigger input in one-shot timer mode)

Symbol	Parameter	Standard		Unit
		Min.	Max.	
$t_{c(TA)}$	TAiIn input cycle time	300		ns
$t_{w(TAH)}$	TAiIn input HIGH pulse width	150		ns
$t_{w(TAL)}$	TAiIn input LOW pulse width	150		ns

Table 1.26.13. Timer A input (external trigger input in pulse width modulation mode)

Symbol	Parameter	Standard		Unit
		Min.	Max.	
$t_{w(TAH)}$	TAiIn input HIGH pulse width	150		ns
$t_{w(TAL)}$	TAiIn input LOW pulse width	150		ns

Table 1.26.14. Timer A input (up/down input in event counter mode)

Symbol	Parameter	Standard		Unit
		Min.	Max.	
$t_{c(UP)}$	TAiOUT input cycle time	3000		ns
$t_{w(UPH)}$	TAiOUT input HIGH pulse width	1500		ns
$t_{w(UPL)}$	TAiOUT input LOW pulse width	1500		ns
$t_{su(UP-TiN)}$	TAiOUT input setup time	600		ns
$t_{h(TiN-UP)}$	TAiOUT input hold time	600		ns

Timing

Timing requirements(referenced to $V_{CC} = 3V$, $V_{SS} = 0V$, at $T_{opr} = -20^{\circ}C$ to $85^{\circ}C$ / $-40^{\circ}C$ to $85^{\circ}C$ (*) unless otherwise specified)* : Specify a product of $-40^{\circ}C$ to $85^{\circ}C$ to use it.**Table 1.26.15. Timer B input (counter input in event counter mode)**

Symbol	Parameter	Standard		Unit
		Min.	Max.	
$t_{c(TB)}$	TBiIn input cycle time (counted on one edge)	150		ns
$t_{w(TBH)}$	TBiIn input HIGH pulse width (counted on one edge)	60		ns
$t_{w(TBL)}$	TBiIn input LOW pulse width (counted on one edge)	60		ns
$t_{c(TB)}$	TBiIn input cycle time (counted on both edges)	300		ns
$t_{w(TBH)}$	TBiIn input HIGH pulse width (counted on both edges)	160		ns
$t_{w(TBL)}$	TBiIn input LOW pulse width (counted on both edges)	160		ns

Table 1.26.16. Timer B input (pulse period measurement mode)

Symbol	Parameter	Standard		Unit
		Min.	Max.	
$t_{c(TB)}$	TBiIn input cycle time	600		ns
$t_{w(TBH)}$	TBiIn input HIGH pulse width	300		ns
$t_{w(TBL)}$	TBiIn input LOW pulse width	300		ns

Table 1.26.17. Timer B input (pulse width measurement mode)

Symbol	Parameter	Standard		Unit
		Min.	Max.	
$t_{c(TB)}$	TBiIn input cycle time	600		ns
$t_{w(TBH)}$	TBiIn input HIGH pulse width	300		ns
$t_{w(TBL)}$	TBiIn input LOW pulse width	300		ns

Table 1.26.18. A-D trigger input

Symbol	Parameter	Standard		Unit
		Min.	Max.	
$t_{c(AD)}$	\overline{ADTRG} input cycle time (trigger able minimum)	1500		ns
$t_{w(ADL)}$	\overline{ADTRG} input LOW pulse width	200		ns

Table 1.26.19. Serial I/O

Symbol	Parameter	Standard		Unit
		Min.	Max.	
$t_{c(CK)}$	CLKi input cycle time	300		ns
$t_{w(CKH)}$	CLKi input HIGH pulse width	150		ns
$t_{w(CKL)}$	CLKi input LOW pulse width	150		ns
$t_d(C-Q)$	TxDi output delay time		160	ns
$t_h(C-Q)$	TxDi hold time	0		ns
$t_{su}(D-C)$	RxDi input setup time	50		ns
$t_h(C-D)$	RxDi input hold time	90		ns

Table 1.26.20. External interrupt \overline{INTi} inputs

Symbol	Parameter	Standard		Unit
		Min.	Max.	
$t_{w(INH)}$	\overline{INTi} input HIGH pulse width	380		ns
$t_{w(INL)}$	\overline{INTi} input LOW pulse width	380		ns

Timing

Switching characteristics (referenced to $V_{CC} = 3V$, $V_{SS} = 0V$ at $T_{opr} = -20^{\circ}C$ to $85^{\circ}C$ / $-40^{\circ}C$ to $85^{\circ}C$ (Note 3), CM15 = "1" unless otherwise specified)

Table 1.26.21. Memory expansion and microprocessor modes (with no wait)

Symbol	Parameter	Measuring condition	Standard		Unit
			Min.	Max.	
$t_{d(BCLK-AD)}$	Address output delay time	Figure 1.26.1		60	ns
$t_{h(BCLK-AD)}$	Address output hold time (BCLK standard)		4		ns
$t_{h(RD-AD)}$	Address output hold time (RD standard)		0		ns
$t_{h(WR-AD)}$	Address output hold time (WR standard)		0		ns
$t_{d(BCLK-CS)}$	Chip select output delay time			60	ns
$t_{h(BCLK-CS)}$	Chip select output hold time (BCLK standard)		4		ns
$t_{d(BCLK-ALE)}$	ALE signal output delay time			60	ns
$t_{h(BCLK-ALE)}$	ALE signal output hold time		-4		ns
$t_{d(BCLK-RD)}$	RD signal output delay time			60	ns
$t_{h(BCLK-RD)}$	RD signal output hold time		0		ns
$t_{d(BCLK-WR)}$	WR signal output delay time			60	ns
$t_{h(BCLK-WR)}$	WR signal output hold time		0		ns
$t_{d(BCLK-DB)}$	Data output delay time (BCLK standard)			80	ns
$t_{h(BCLK-DB)}$	Data output hold time (BCLK standard)		4		ns
$t_{d(DB-WR)}$	Data output delay time (WR standard)		(Note1)		ns
$t_{h(WR-DB)}$	Data output hold time (WR standard)(Note2)		0		ns

Note 1: Calculated according to the BCLK frequency as follows:

$$t_{d(DB-WR)} = \frac{10^9}{f(BCLK) \times 2} - 80 \quad [ns]$$

Note 2: This is standard value shows the timing when the output is off, and doesn't show hold time of data bus.
Hold time of data bus is different by capacitor volume and pull-up (pull-down) resistance value.
Hold time of data bus is expressed in
 $t = -CR \times \ln(1 - V_{OL} / V_{CC})$
by a circuit of the right figure.
For example, when $V_{OL} = 0.2V_{CC}$, $C = 30pF$, $R = 1k\Omega$, hold time of output "L" level is

$$t = -30pF \times 1k\Omega \times \ln(1 - 0.2V_{CC} / V_{CC}) = 6.7ns.$$

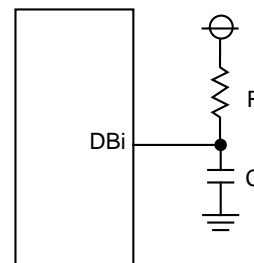

Note 3: Specify a product of $-40^{\circ}C$ to $85^{\circ}C$ to use it.

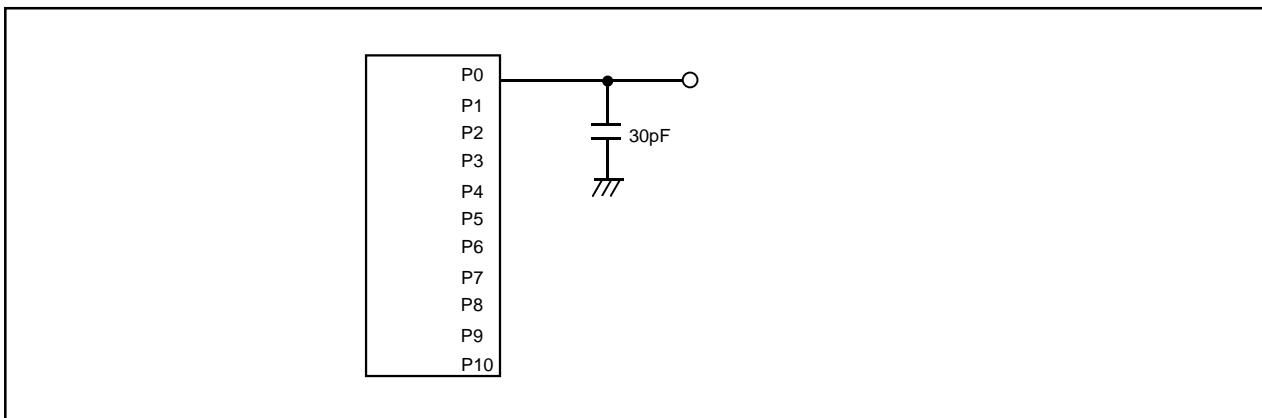

Figure 1.26.1. Port P0 to P10 measurement circuit

Switching characteristics (referenced to $V_{CC} = 3V$, $V_{SS} = 0V$ at $T_{opr} = -20^{\circ}C$ to $85^{\circ}C$ / $-40^{\circ}C$ to $85^{\circ}C$ (Note 3), CM15 = "1" unless otherwise specified)

Table 1.26.22. Memory expansion and microprocessor modes
(when accessing external memory area with wait)

Symbol	Parameter	Measuring condition	Standard		Unit
			Min.	Max.	
$t_{d(BCLK-AD)}$	Address output delay time	Figure 1.31.1		60	ns
$t_{h(BCLK-AD)}$	Address output hold time (BCLK standard)		4		ns
$t_{h(RD-AD)}$	Address output hold time (RD standard)		0		ns
$t_{h(WR-AD)}$	Address output hold time (WR standard)		0		ns
$t_{d(BCLK-CS)}$	Chip select output delay time			60	ns
$t_{h(BCLK-CS)}$	Chip select output hold time (BCLK standard)		4		ns
$t_{d(BCLK-ALE)}$	ALE signal output delay time			60	ns
$t_{h(BCLK-ALE)}$	ALE signal output hold time		-4		ns
$t_{d(BCLK-RD)}$	RD signal output delay time			60	ns
$t_{h(BCLK-RD)}$	RD signal output hold time		0		ns
$t_{d(BCLK-WR)}$	WR signal output delay time			60	ns
$t_{h(BCLK-WR)}$	WR signal output hold time		0		ns
$t_{d(BCLK-DB)}$	Data output delay time (BCLK standard)			80	ns
$t_{h(BCLK-DB)}$	Data output hold time (BCLK standard)		4		ns
$t_{d(DB-WR)}$	Data output delay time (WR standard)		(Note1)		ns
$t_{h(WR-DB)}$	Data output hold time (WR standard)(Note2)		0		ns

Note 1: Calculated according to the BCLK frequency as follows:

$$t_{d(DB-WR)} = \frac{10^9}{f(BCLK)} - 80 \quad [ns]$$

Note 2: This is standard value shows the timing when the output is off, and doesn't show hold time of data bus. Hold time of data bus is different by capacitor volume and pull-up (pull-down) resistance value.

Hold time of data bus is expressed in

$$t = -CR \times \ln(1 - V_{OL} / V_{CC})$$

by a circuit of the right figure.

For example, when $V_{OL} = 0.2V_{CC}$, $C = 30pF$, $R = 1k\Omega$, hold time of output "L" level is

$$t = -30pF \times 1k\Omega \times \ln(1 - 0.2V_{CC} / V_{CC}) = 6.7ns.$$

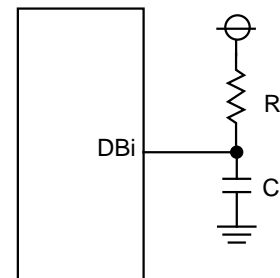

Note 3: Specify a product of $-40^{\circ}C$ to $85^{\circ}C$ to use it.

Timing

Switching characteristics (referenced to $V_{CC} = 3V$, $V_{SS} = 0V$ at $T_{op} = -20^{\circ}C$ to $85^{\circ}C$ / $-40^{\circ}C$ to $85^{\circ}C$ (Note 2), CM15 = "1" unless otherwise specified)

Table 1.26.23. Memory expansion and microprocessor modes
(when accessing external memory area with wait, and select multiplexed bus)

Symbol	Parameter	Measuring condition	Standard		Unit
			Min.	Max.	
$t_{d(BCLK-AD)}$	Address output delay time	Figure 1.26.1		60	ns
$t_{h(BCLK-AD)}$	Address output hold time (BCLK standard)		4		ns
$t_{h(RD-AD)}$	Address output hold time (RD standard)		(Note 1)		ns
$t_{h(WR-AD)}$	Address output hold time (WR standard)		(Note 1)		ns
$t_{d(BCLK-CS)}$	Chip select output delay time			60	ns
$t_{h(BCLK-CS)}$	Chip select output hold time (BCLK standard)		4		ns
$t_{h(RD-CS)}$	Chip select output hold time (RD standard)		(Note 1)		ns
$t_{h(WR-CS)}$	Chip select output hold time (WR standard)		(Note 1)		ns
$t_{d(BCLK-RD)}$	RD signal output delay time			60	ns
$t_{h(BCLK-RD)}$	RD signal output hold time		0		ns
$t_{d(BCLK-WR)}$	WR signal output delay time			60	ns
$t_{h(BCLK-WR)}$	WR signal output hold time		0		ns
$t_{d(BCLK-DB)}$	Data output delay time (BCLK standard)			80	ns
$t_{h(BCLK-DB)}$	Data output hold time (BCLK standard)		4		ns
$t_{d(DB-WR)}$	Data output delay time (WR standard)		(Note 1)		ns
$t_{h(WR-DB)}$	Data output hold time (WR standard)		(Note 1)		ns
$t_{d(BCLK-ALE)}$	ALE signal output delay time (BCLK standard)			60	ns
$t_{h(BCLK-ALE)}$	ALE signal output hold time (BCLK standard)		-4		ns
$t_{d(AD-ALE)}$	ALE signal output delay time (Address standard)		(Note 1)		ns
$t_{h(ALE-AD)}$	ALE signal output hold time (Address standard)		40		ns
$t_{d(AD-RD)}$	Post-address RD signal output delay time	0		ns	
$t_{d(AD-WR)}$	Post-address WR signal output delay time	0		ns	
$t_{dZ(RD-AD)}$	Address output floating start time		8	ns	

Note 1: Calculated according to the BCLK frequency as follows:

$$t_{h(RD - AD)} = \frac{10^9}{f(BCLK) \times 2} \quad [ns]$$

$$t_{h(WR - AD)} = \frac{10^9}{f(BCLK) \times 2} \quad [ns]$$

$$t_{h(RD - CS)} = \frac{10^9}{f(BCLK) \times 2} \quad [ns]$$

$$t_{h(WR - CS)} = \frac{10^9}{f(BCLK) \times 2} \quad [ns]$$

$$t_{d(DB - WR)} = \frac{10^9 \times 3}{f(BCLK) \times 2} - 80 \quad [ns]$$

$$t_{h(WR - DB)} = \frac{10^9}{f(BCLK) \times 2} \quad [ns]$$

$$t_{d(AD - ALE)} = \frac{10^9}{f(BCLK) \times 2} - 45 \quad [ns]$$

Note 2: Specify a product of $-40^{\circ}C$ to $85^{\circ}C$ to use it.

Timing

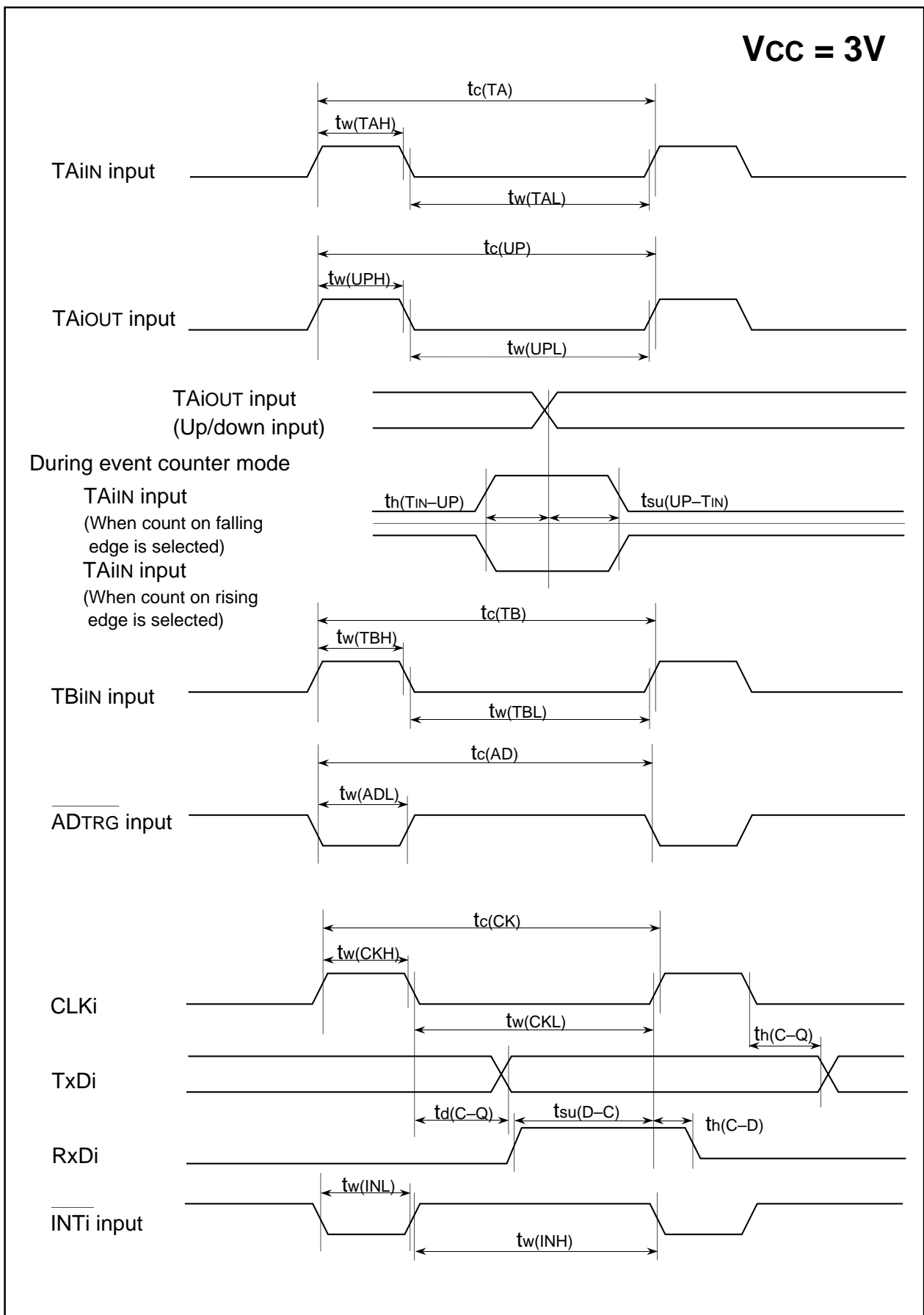

Figure 1.26.2. V_{CC}=3V timing diagram (1)

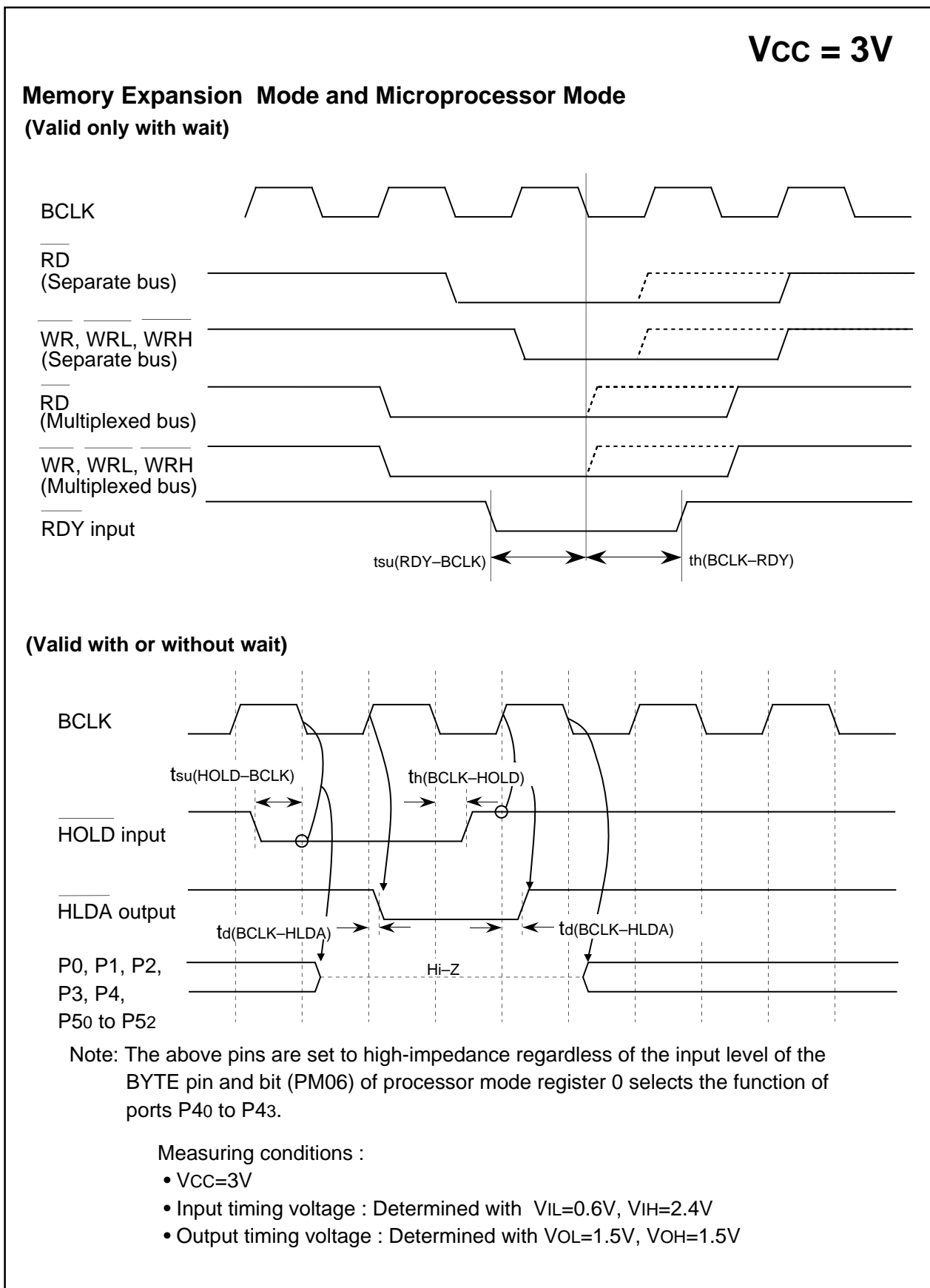
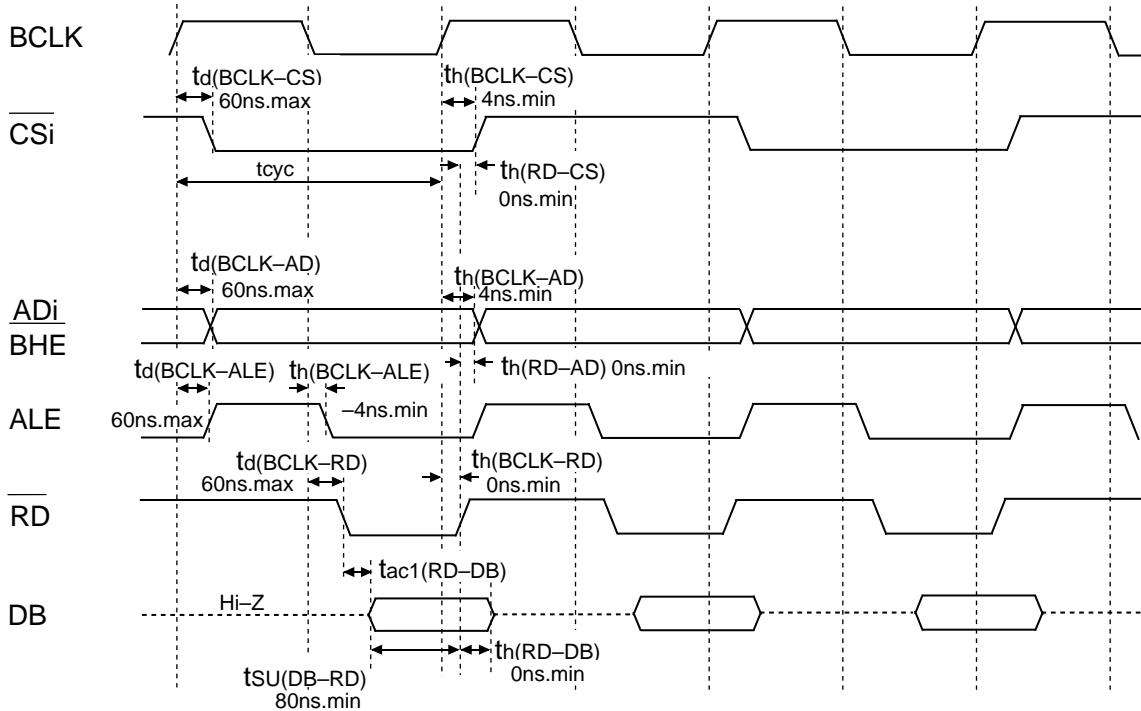

Figure 1.26.3. VCC=3V timing diagram (2)

**Memory Expansion Mode and Microprocessor Mode
(With no wait)**

VCC = 3V

Read timing



Write timing

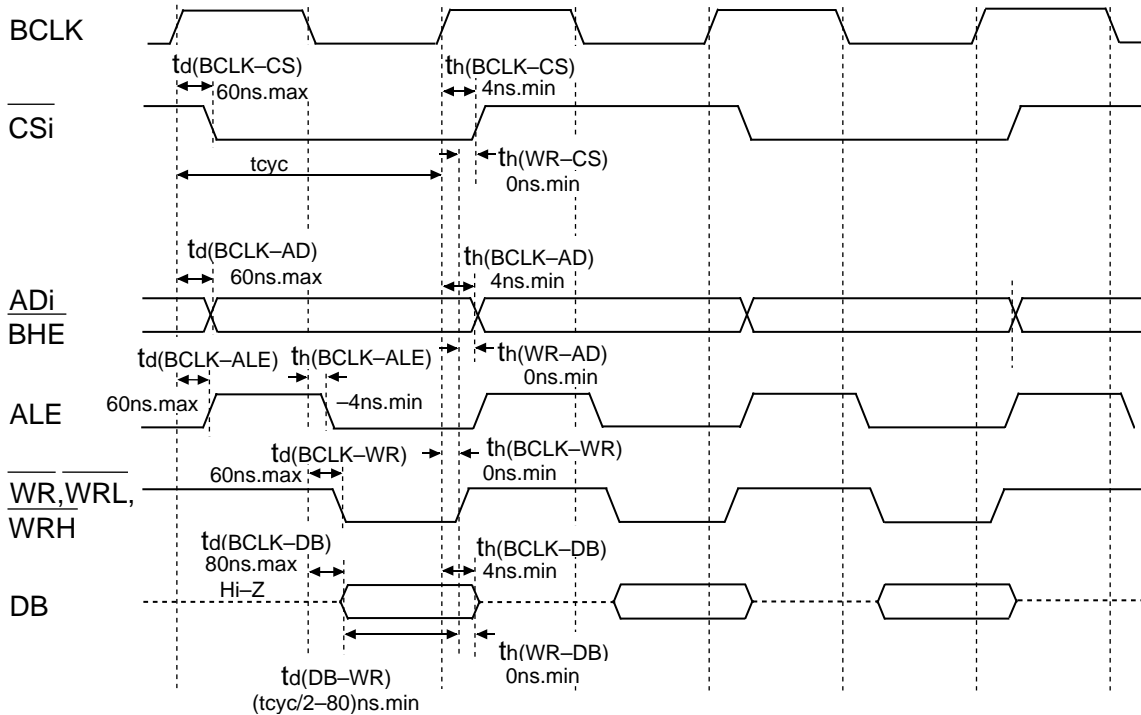

Figure 1.26.4. VCC=3V timing diagram (3)

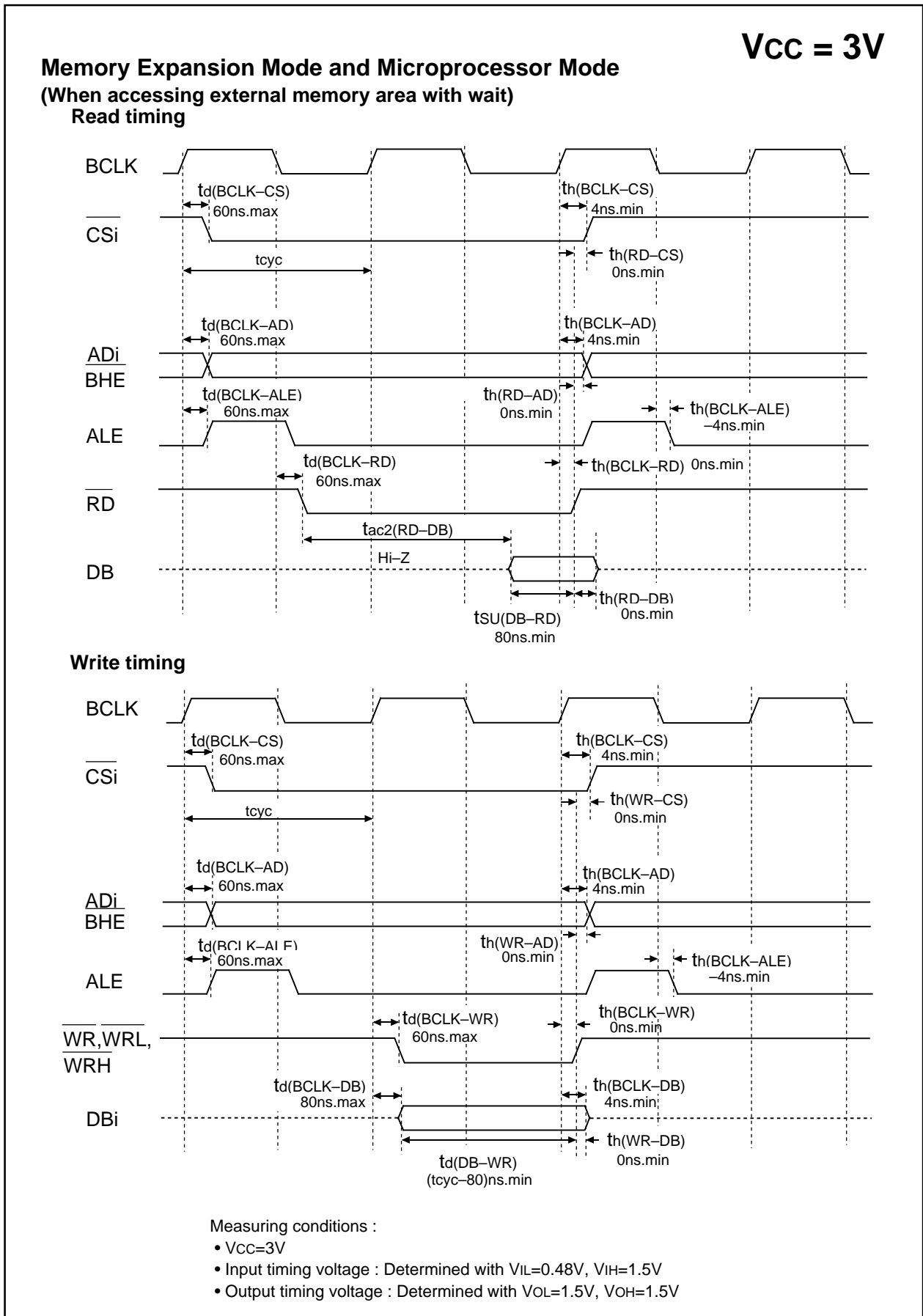

Figure 1.26.5. VCC=3V timing diagram (4)

VCC = 3V

Memory Expansion Mode and Microprocessor Mode

(When accessing external memory area with wait, and select multiplexed bus)

Read timing

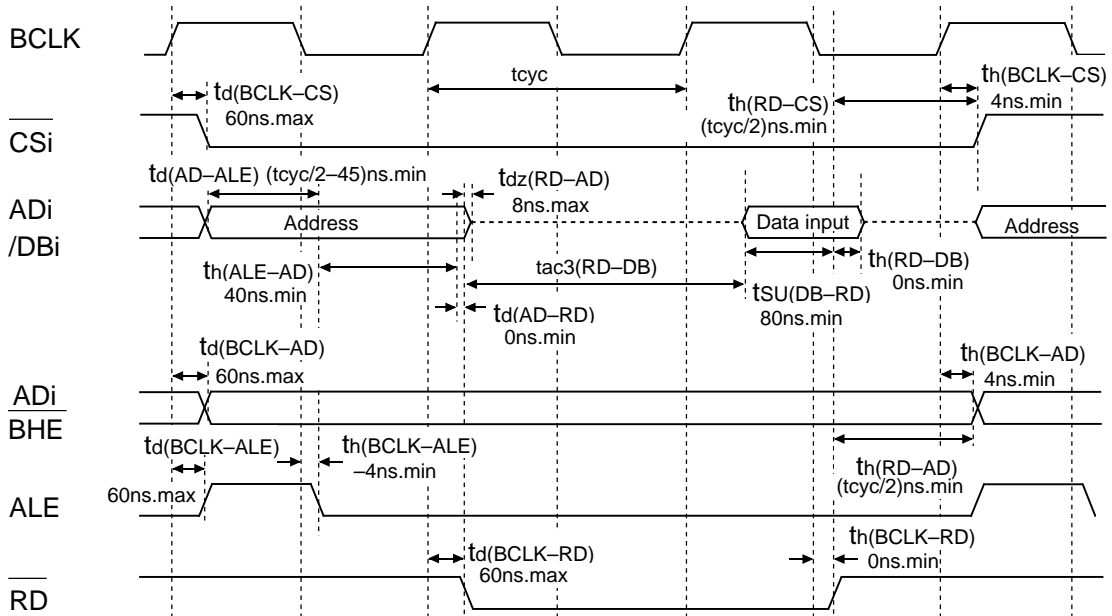

Write timing

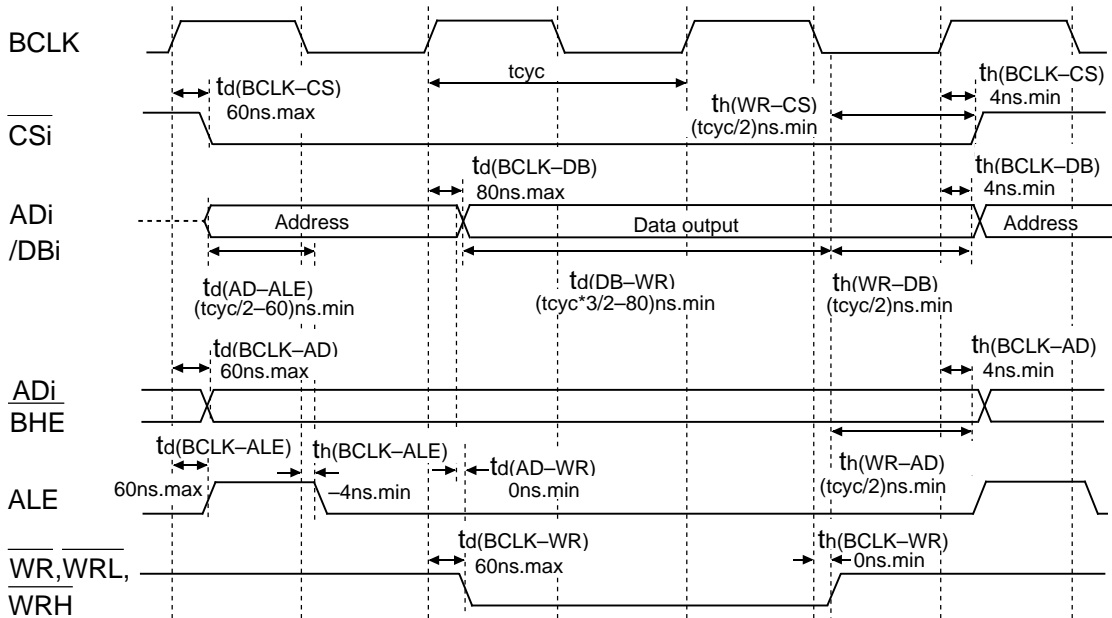

Measuring conditions :

- VCC=3V
- Input timing voltage : Determined with $V_{IL}=0.48V, V_{IH}=1.5V$
- Output timing voltage : Determined with $V_{OL}=1.5V, V_{OH}=1.5V$

Figure 1.26.6. VCC=3V timing diagram (5)

GZZ-SH13-95B<02A0>

**MITSUBISHI ELECTRIC-CHIP 16-BIT
MICROCOMPUTER M30620MCM-XXXFP/GP
MASK ROM CONFIRMATION FORM**

Mask ROM number	
-----------------	--

Receipt	Date :	
	Section head signature	Supervisor signature

Note : Please complete all items marked * .

* Customer	Company name	TEL ()	Issuance signature	Submitted by	Supervisor
	Date issued	Date :			

*1. Check sheet

Mitsubishi processes the mask files generated by the mask file generation utilities out of those held on the floppy disks you give in to us, and forms them into masks. Hence, we assume liability provided that there is any discrepancy between the contents of these mask files and the ROM data to be burned into products we produce. Check thoroughly the contents of the mask files you give in.

Prepare 3.5 inches 2HD (IBM format) floppy disks. And store only one mask file in a floppy disk.

Microcomputer type No. : M30620MCM-XXXFP M30620MCM-XXXGP

File code :

--	--	--	--	--	--	--	--

 (hex)

Mask file name :

--	--	--	--	--	--	--	--

 .MSK (alpha-numeric 8-digit)

*2. Mark specification

The mark specification differs according to the type of package. After entering the mark specification on the separate mark specification sheet (for each package), attach that sheet to this masking check sheet for submission to Mitsubishi.

For the M30620MCM-XXXFP, submit the 100P6S mark specification sheet. For the M30620MCM-XXXGP, submit the 100P6Q mark specification sheet.

*3. Usage Conditions

For our reference when of testing our products, please reply to the following questions about the usage of the products you ordered.

(1) Which kind of X_{IN}-X_{OUT} oscillation circuit is used?

- Ceramic resonator Quartz-crystal oscillator
 External clock input Other ()

What frequency do not use?

f(X_{IN}) =

--

 MHz

GZZ-SH13-95B<02A0>

Mask ROM number	
-----------------	--

**MITSUBISHI ELECTRIC-CHIP 16-BIT
MICROCOMPUTER M30620MCM-XXXFP/GP
MASK ROM CONFIRMATION FORM**

(2) Which kind of XCIN-XCOUT oscillation circuit is used?

- Ceramic resonator Quartz-crystal oscillator
 External clock input Other ()

What frequency do not use?

f(XCIN) = kHz

(3) Which operation mode do you use?

- Single-chip mode Memory expansion mode
 Microprocessor mode

(4) Which operating supply voltage do you use?

(Circle the operating voltage range of use)

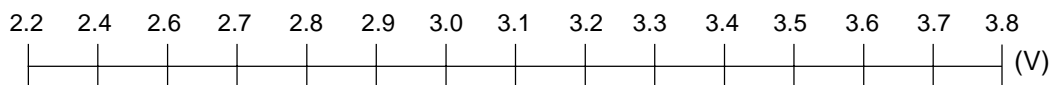

(5) Which operating ambient temperature do you use?

(Circle the operating temperature range of use)

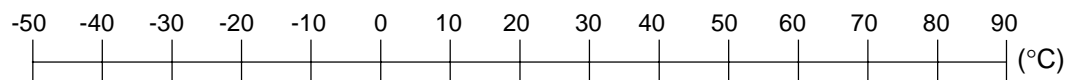

(6) Do you use I²C (Inter IC) bus function?

- Not use Use

(7) Do you use IE (Inter Equipment) bus function?

- Not use Use

Thank you cooperation.

*4. Special item (Indicate none if there is not specified item)

GZZ-SH13-48B<98A1>

**MITSUBISHI ELECTRIC-CHIP 16-BIT
MICROCOMPUTER M30624MGM-XXXFP/GP
MASK ROM CONFIRMATION FORM**

Mask ROM number	
-----------------	--

Receipt	Date :	
	Section head signature	Supervisor signature

Note : Please complete all items marked * .

* Customer	Company name	TEL ()	Issuance signature	Submitted by	Supervisor
	Date issued	Date :			

*1. Check sheet

Mitsubishi processes the mask files generated by the mask file generation utilities out of those held on the floppy disks you give in to us, and forms them into masks. Hence, we assume liability provided that there is any discrepancy between the contents of these mask files and the ROM data to be burned into products we produce. Check thoroughly the contents of the mask files you give in.

Prepare 3.5 inches 2HD (IBM format) floppy disks. And store only one mask file in a floppy disk.

Microcomputer type No. : M30624MGM-XXXFP M30624MGM-XXXGP

File code :

--	--	--	--	--	--	--	--

 (hex)

Mask file name :

--	--	--	--	--	--	--	--

 .MSK (alpha-numeric 8-digit)

*2. Mark specification

The mark specification differs according to the type of package. After entering the mark specification on the separate mark specification sheet (for each package), attach that sheet to this masking check sheet for submission to Mitsubishi.

For the M30624MGM-XXXFP, submit the 100P6S mark specification sheet. For the M30624MGM-XXXGP, submit the 100P6Q mark specification sheet.

*3. Usage Conditions

For our reference when of testing our products, please reply to the following questions about the usage of the products you ordered.

(1) Which kind of X_{IN}-X_{OUT} oscillation circuit is used?

- Ceramic resonator Quartz-crystal oscillator
 External clock input Other ()

What frequency do not use?

f(X_{IN}) =

--

 MHz

GZZ-SH13-48B<98A1>

Mask ROM number	
-----------------	--

**MITSUBISHI ELECTRIC-CHIP 16-BIT
MICROCOMPUTER M30624MGM-XXXFP/GP
MASK ROM CONFIRMATION FORM**

(2) Which kind of XCIN-XCOUT oscillation circuit is used?

- Ceramic resonator Quartz-crystal oscillator
 External clock input Other ()

What frequency do not use?

$f(XCIN) =$ kHz

(3) Which operation mode do you use?

- Single-chip mode Memory expansion mode
 Microprocessor mode

(4) Which operating supply voltage do you use?

(Circle the operating voltage range of use)

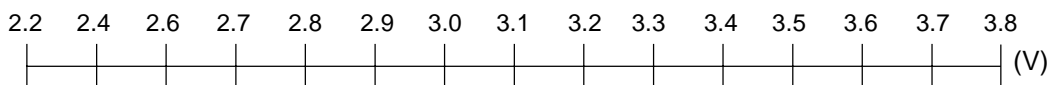

(5) Which operating ambient temperature do you use?

(Circle the operating temperature range of use)

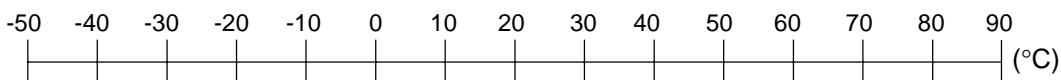

(6) Do you use I²C (Inter IC) bus function?

- Not use Use

(7) Do you use IE (Inter Equipment) bus function?

- Not use Use

Thank you cooperation.

*4. Special item (Indicate none if there is not specified item)

Differences between M16C/62M (Low voltage version) and M30624FGLFP/GP

Item	M16C/62M (Low voltage version)	M30624FGLFP/GP
Memory area	1 Mbyte fixed	Memory expansion 1.2 Mbytes mode 4 Mbytes mode
Serial I/O	No CTS/RTS separate function	CTS/RTS separate function
IIC bus mode	Analog or digital delay is selected as SDA delay	Only analog delay is selected as SDA delay
Memory version	Mask ROM version Flash memory version	Flash memory version only
Standard serial I/O mode (Flash memory version)	Clock synchronized Clock asynchronous	Clock synchronized only

Version	Contents for change	Revision date
REV. B1	Page 8-17 All symbols of Ta are revised to Topr.	01.6.22
Revision history		M16C/62M Group data sheet

Keep safety first in your circuit designs!

- Mitsubishi Electric Corporation puts the maximum effort into making semiconductor products better and more reliable, but there is always the possibility that trouble may occur with them. Trouble with semiconductors may lead to personal injury, fire or property damage. Remember to give due consideration to safety when making your circuit designs, with appropriate measures such as (i) placement of substitutive, auxiliary circuits, (ii) use of non-flammable material or (iii) prevention against any malfunction or mishap.

Notes regarding these materials

- These materials are intended as a reference to assist our customers in the selection of the Mitsubishi semiconductor product best suited to the customer's application; they do not convey any license under any intellectual property rights, or any other rights, belonging to Mitsubishi Electric Corporation or a third party.
- Mitsubishi Electric Corporation assumes no responsibility for any damage, or infringement of any third-party's rights, originating in the use of any product data, diagrams, charts, programs, algorithms, or circuit application examples contained in these materials.
- All information contained in these materials, including product data, diagrams, charts, programs and algorithms represents information on products at the time of publication of these materials, and are subject to change by Mitsubishi Electric Corporation without notice due to product improvements or other reasons. It is therefore recommended that customers contact Mitsubishi Electric Corporation or an authorized Mitsubishi Semiconductor product distributor for the latest product information before purchasing a product listed herein.
The information described here may contain technical inaccuracies or typographical errors. Mitsubishi Electric Corporation assumes no responsibility for any damage, liability, or other loss rising from these inaccuracies or errors.
Please also pay attention to information published by Mitsubishi Electric Corporation by various means, including the Mitsubishi Semiconductor home page (<http://www.mitsubishichips.com>).
- When using any or all of the information contained in these materials, including product data, diagrams, charts, programs, and algorithms, please be sure to evaluate all information as a total system before making a final decision on the applicability of the information and products. Mitsubishi Electric Corporation assumes no responsibility for any damage, liability or other loss resulting from the information contained herein.
- Mitsubishi Electric Corporation semiconductors are not designed or manufactured for use in a device or system that is used under circumstances in which human life is potentially at stake. Please contact Mitsubishi Electric Corporation or an authorized Mitsubishi Semiconductor product distributor when considering the use of a product contained herein for any specific purposes, such as apparatus or systems for transportation, vehicular, medical, aerospace, nuclear, or undersea repeater use.
- The prior written approval of Mitsubishi Electric Corporation is necessary to reprint or reproduce in whole or in part these materials.
- If these products or technologies are subject to the Japanese export control restrictions, they must be exported under a license from the Japanese government and cannot be imported into a country other than the approved destination.
Any diversion or reexport contrary to the export control laws and regulations of Japan and/or the country of destination is prohibited.
- Please contact Mitsubishi Electric Corporation or an authorized Mitsubishi Semiconductor product distributor for further details on these materials or the products contained therein.

MITSUBISHI SEMICONDUCTORS
M16C/62M Group (Low voltage version) Data Sheet REV.B1

June First Edition 2001

Edition by
Committee of editing of Mitsubishi Semiconductor

Published by
Mitsubishi Electric Corp., Kitaitami Works

This book, or parts thereof, may not be reproduced in any form without
permission of Mitsubishi Electric Corporation.

©2001 MITSUBISHI ELECTRIC CORPORATION