

CFPT-5300 LEADED TCXO

ISSUE 5; 15 DECEMBER 2009 - RoHS 2002/95/EC

Description

- Ultra high stability 14-pin DIL hermetically sealed TCXO with wide operating temperature range. Manufactured for us by Rakon, its wide frequency range and operating temperature range, coupled with high stability and linear frequency pulling make it the ideal reference oscillator. Its ability to function down to supply voltage of 2.4V and low power consumption makes it suitable for a wide range of applications.

Package Outline

- 14-pin DIL

Standard Frequency

- 3.2, 4.096, 5, 6.4, 8.192, 9.6, 10, 12.8, 13, 14.4, 14.85, 16.384, 16.8, 19.2, 19.44, 19.8, 20, 32.768, 38.88, 40MHz
- Other frequencies in the range 1.25MHz to 40MHz may be available, please contact our sales office

Output Compatibility & Load (standard)

- HCMOS 15pF max

Output Compatibility & Load (options)

- ACMOS 50pF max
- Sinewave, >1.0pk-pk, 10kΩ // 10pF load
- Clipped Sinewave, >0.8Vpk-pk, 10kΩ // 10pF load

Sinewave and Clipped Sinewave signals are superimposed on a DC offset, to remove this offset insert an external coupling capacitor in series with the output

Supply Voltages

- 3.3V or 5.0V

Non-standard supply voltages in the range 2.4V to 6.0V are available on request, please contact our sales office

Supply Current

- HCMOS
Typically: $1 + \text{Frequency(MHz)} * \text{Supply(V)} * \{\text{Load(pF)} + 15\} * 10^{-3} \text{mA}$ e.g. 20MHz, 5V, 15pF ≈ 4mA
- Sinewave: <8mA
- Clipped Sinewave
 $1 + \text{Frequency(MHz)} * 1.2 * \{\text{Load(pF)} + 30\} * 10^{-3} \text{mA}$

Ageing

- ±1ppm maximum in first year, frequency <20MHz
- ±3ppm maximum for 10 years, frequency <20MHz
- ±2ppm maximum in first year, frequency >20MHz
- ±5ppm maximum for 10 years, frequency >20MHz

Frequency Stability

- Temperature: see table
- Supply Voltage Variation ±10% < ±0.2ppm*
- Load co-efficient 15pF ±5pF < ±0.2ppm*
*Dependent on frequency and output type

Frequency Adjustment Option A (standard):

- Control Voltage 1.5V±1.0V, applied to pin 1
- > ±5ppm*, frequency < 20MHz

- > ±7ppm, frequency > 20MHz
- Linearity <3% (Positive)
- Input resistance >100kΩ
- Modulation Bandwidth >2kHz

Frequency Adjustment Option B:

- >±5ppm* (>±7ppm if frequency >20MHz) by means of an external 100kΩ potentiometer connected as a variable resistor from pin 1 to GND

Frequency Adjustment Option C:

- No frequency adjustment, initial calibration @25°C <±1.0ppm

*Higher adjustment range up to ±50ppm and non-standard control voltage ranges are available on request. This may not be compatible with all stability options. Please contact our sales office

Storage Temperature Range

- 55 to 95°C

Environmental

- Bump: IEC 60068-2-29, Test Eb, 4000 ±10 bumps at 390m/s² in each of the three mutually perpendicular planes
- Shock: IEC 60068-2-27 Test Ea, 980m/s² acceleration for 6ms duration, 3 shocks in each direction along three mutually perpendicular planes
- Solderability: IEC 60068-2-20, Test T, method 1 (solder bath): Temperature 235°C
- Vibration: IEC 60068-2-6 Test Fc Procedure B4, 10-60Hz 1.5mm displacement, 60-2000Hz at 98.1m/s², 30 minutes in each of three mutually perpendicular planes at 1 octave per minute
- Damp Heat (steady state): IEC 60068-2-3, Test Ca, duration 56 days
- Robustness of Termination: IEC 60068-2-21, Test Ua (tensile): Force 1kg
- Sealing: IEC 60068-2-17, Test Qc (gross) & Test Qk (fine)
- Immersion in Solvents: IEC 60068-2-45, Test Xa

Marking Includes

- Model + Part Number + Frequency + Pin 1 / Static sensitivity identified (Triangle) + Date Code

Packaging

- Bulk

Minimum Order Information Required

- Frequency + Model Number + Frequency Stability vs Operating Temperature Code + Frequency Adjustment Code

Phase Noise (typical figures)

Frequency	Frequency offset from carrier: 10Hz	Frequency offset from carrier: 100Hz	Frequency offset from carrier: 1kHz	Frequency offset from carrier: 10kHz	Frequency offset from carrier: 100kHz
10.0MHz	-95 dBc/Hz	-120 dBc/Hz	-135 dBc/Hz	-140 dBc/Hz	-145 dBc/Hz
20.0MHz	-85 dBc/Hz	-110 dBc/Hz	-125 dBc/Hz	-135 dBc/Hz	-140 dBc/Hz
40.0MHz	-75 dBc/Hz	-100 dBc/Hz	-120 dBc/Hz	-130 dBc/Hz	-135 dBc/Hz

Electrical Specification - maximum limiting values

Frequency Range	Supply Voltage	Output	Output Levels	Rise Time (tr)	Fall Time (tf)	Duty Cycle	Model Number
1.255 to 40.0MHz	3.3V ±10%	HCMOS 15pF	Voh ≥ 90% Vs	8ns	8ns	45/55%	CFPT-5301
	5.0V ±10%		Vol ≤ 10% Vs	7ns	7ns		CFPT-5302

Frequency Stabilities over Operating Temperature Range

Operating Temperature Ranges	Frequency Stabilities v Operating Temperature Range				
	±0.3ppm	±0.5ppm	±0.8ppm	±1.0ppm	±1.5ppm
0 to 70°C	Code AC*	Code EC	Code BC	Code FC	Code CC
-20 to 70°C	Code AS*	Code ES	Code BS	Code FS	Code CS
-30 to 75°C	-	Code EU*	Code BU	Code FU	Code CU
-40 to 85°C	-	Code EX*	Code BX	Code FX	Code CX
-55 to 95°C	-	-	-	Code FA*	Code CA*

Ordering Example 10.0MHz CFPT-5301 FX A

Frequency _____

Model No. _____

Frequency stability vs Operating Temperature Code _____

Frequency Adjustment Code: A, B, C _____

Note: *Codes may not be available for all frequencies

Outline (mm)

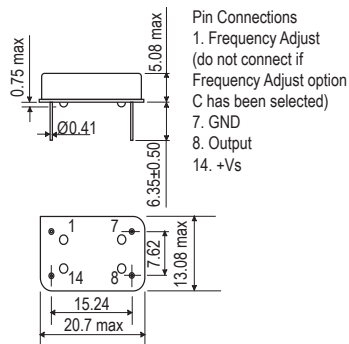

Output Waveform

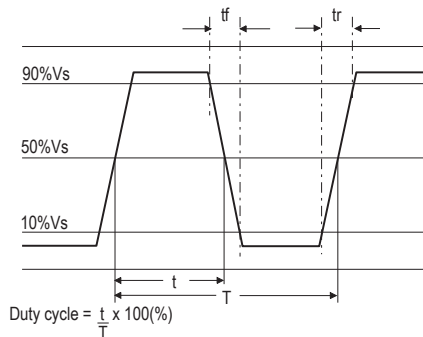

TCXOs