

Function Block Diagram

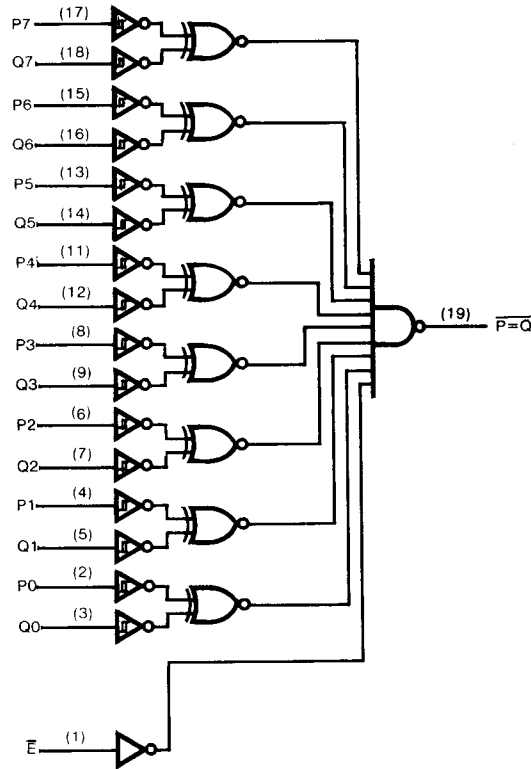

Switching Characteristics, $V_{CC} = 5V$, $T_A = 25^\circ C$

PARAMETER	FROM(INPUT)	TO(OUTPUT)	TEST CONDITION#	MIN	TYP	MAX	UNIT
t_{PLH}	P	$P=Q$	$C_L = 45pF$ $R_L = 667\Omega$ all other inputs low state	12	18	ns	
t_{PHL}				17	23		
t_{PLH}	Q	$\overline{P=Q}$		12	18	ns	
t_{PHL}				17	23		
t_{PLH}	\overline{E}	$\overline{P=Q}$		12	18	ns	
t_{PHL}				13	20		

For load circuit and voltage waveforms, see page 3-11.

Recommended Operating Conditions

SYMBOL	PARAMETER		MIN	NOM	MAX	UNIT
V_{CC}	Supply voltage	54	4.5	5	5.5	V
		74	4.75	5	5.25	
I_{OH}	High-level output current	54			-400	μ A
		74			-400	
I_{OL}	Low-level output current	54			12	mA
		74			24	
T_A	Operating free-air temperature	54	-55		125	$^{\circ}$ C
		74	0		70	

Electrical Characteristics over recommended operating free-air temperature range (unless otherwise noted)

SYMBOL	PARAMETER	TEST CONDITIONS	MIN	TYP (Note 1)	MAX	UNIT	
V_{IH}	High-level input voltage			2		V	
V_{IL}	Low-level input voltage		54		0.7	V	
			74		0.8		
V_{IK}	Input clamp voltage	$V_{CC} = \text{Min}, I_I = -18\text{mA}$			-1.5	V	
$V_{T+} - V_{T-}$	Hysteresis	$V_{CC} = \text{Min}$	0.2	0.4		V	
V_{OH}	High-level output voltage	$V_{CC} = \text{Min}, V_{IH} = \text{Min}$	54	2.5	3.4	V	
		$V_{IL} = \text{Max}, I_{OH} = \text{Max}$	74	2.7	3.4		
V_{OL}	Low-level output voltage	$V_{CC} = \text{Min}$			0.25	0.4	V
		$V_{IL} = \text{Max}$	$I_{OL} = 12\text{mA}$	54, 74			
		$V_{IH} = \text{Min}$	$I_{OL} = 24\text{mA}$	54	0.35	0.5	
I_I	Input current at maximum input voltage	$V_{CC} = \text{Max}$	$V_I = 5.5\text{V Q inputs}$		0.1		mA
			$V_I = 7\text{V other inputs}$		0.1		
I_{IH}	High-level input current	$V_{CC} = \text{Max}, V_I = 2.7\text{V}$			20	μ A	
I_{IL}	Low-level input current	$V_{CC} = \text{Max}$	$V_I = 0.4\text{V Q inputs}$		-0.4		mA
			$V_I = 0.4\text{V other inputs}$		-0.2		
I_{OS}	Short-circuit output current	$V_{CC} = \text{Max}$ (Note 2)	-20		-100	mA	
I_{CC}	Supply current	$V_{CC} = 5.25\text{V},$ (Note 3)		40	65	mA	

Note 1: All typical values are at $V_{CC} = 5\text{V}, T_A = 25^{\circ}\text{C}$.

Note 2: Not more than one output should be shorted at a time, and the duration should not exceed one second.

Note 3: I_{CC} is measured with any \bar{E} inputs grounded, all other inputs at 4.5V, and all outputs open.