

Monolithic Integrated Feature Phone Circuit

Description

The telephone circuit U4089B is a linear integrated circuit for use in feature phones, answering machines and fax machines. It contains the speech circuit, sidetone equivalent and ear protection rectifiers. The circuit is line-powered and contains all components necessary for the amplification of signals and adaptation to the line.

An integrated voice switch with loudspeaker amplifier enables loudhearing or hands-free operation. With an anti-feedback function, acoustical feedback during loudhearing can be reduced significantly. The generated supply voltage is suitable for a wide range of peripheral circuits.

Features

- DC characteristic adjustable
- Transmit and receive gain adjustable
- Symmetrical input of microphone amplifier
- Anti-clipping in transmit direction
- Automatic line-loss compensation
- Built-in ear protection
- DTMF and MUTE input
- Adjustable sidetone suppression independent of sending and receiving amplification
- Integrated amplifier for loudhearing operation
- Anti-clipping for loudspeaker amplifier
- Improved acoustical feedback suppression

- Selectable line impedance
- Voice switch
- Supply voltages for all functional blocks of a subscriber set
- Operation possible from 10-mA line current

Benefits

- Complete system integration of analog signal processing on one chip
- Very few external components

Applications

Feature phone, answering machine, fax machine, speaker phone

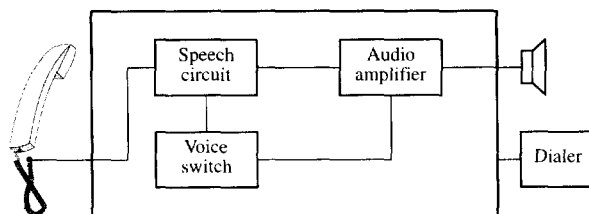

12683

Ordering Information

Type	Package	Remarks
U4089B	SDIP30	

Block Diagram

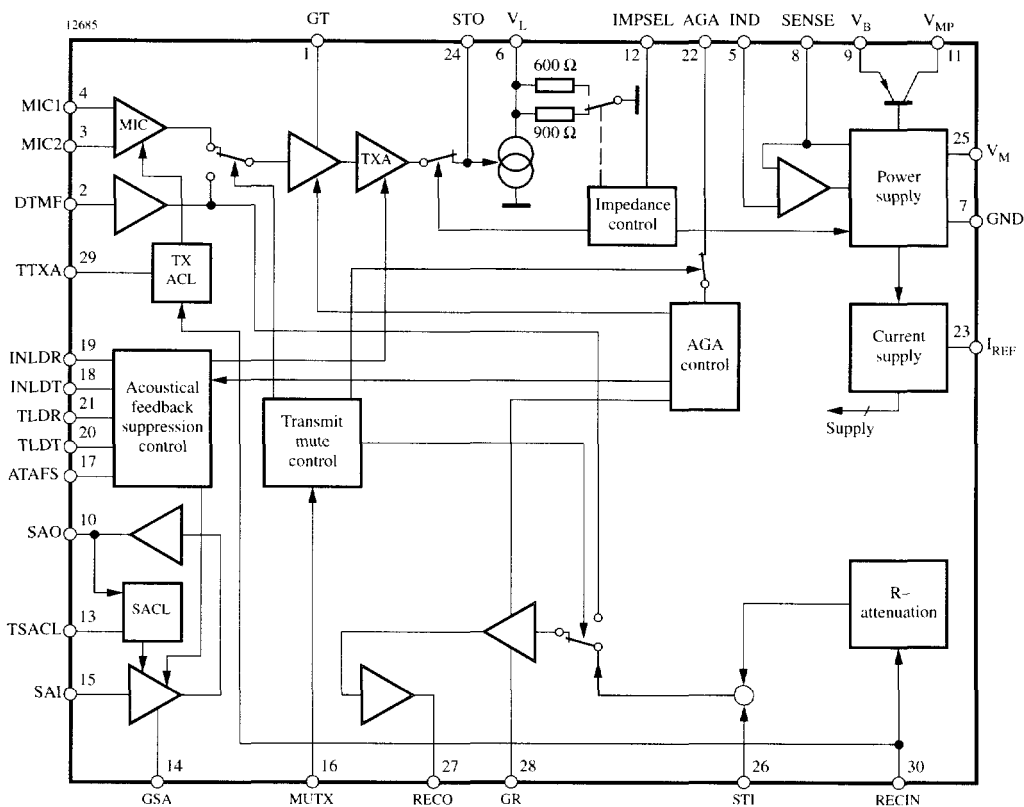
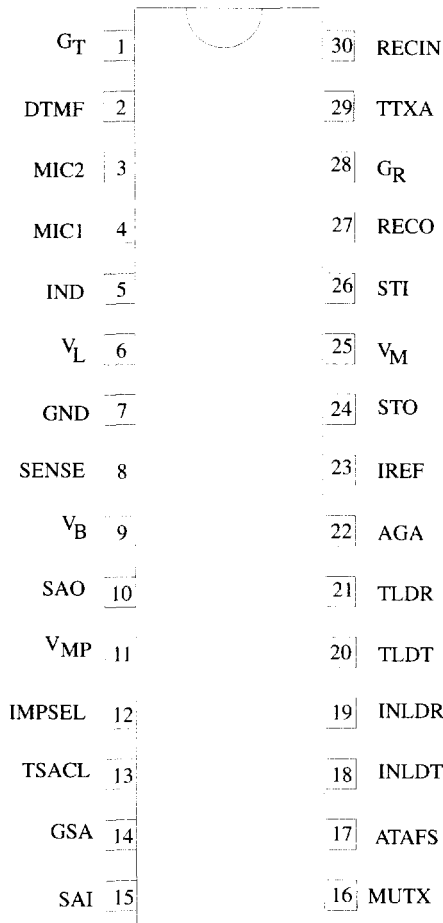

Figure 1. Block diagram

Table 4. Typical values of external components (figure next page)

Name	Value	Name	Value	Name	Value	Name	Value
C ₂	4.7 nF	C ₁₆	47 μF	R ₃	>68 kΩ	R ₁₆	1 kΩ
C ₃	10 μF	C ₁₇	10 μF	R ₄	10 kΩ	R ₁₇	1.2 kΩ
C ₄	220 μF	C ₁₈	10 μF	R ₆	62 kΩ	R ₁₈	30 kΩ
C ₅	47 μF	C ₂₁	1 μF	R ₈	22 kΩ	R ₂₁	15 kΩ
C ₇	1 μF	C ₂₃	6.8 nF	R ₉	330 kΩ	R ₂₂	330 kΩ
C ₈	100 μF	C ₂₄	10 nF	R ₁₀	3 kΩ	R ₂₃	220 kΩ
C ₁₀	150 nF	C ₂₅	100 nF	R ₁₁	62 kΩ	R ₂₄	68 kΩ
C ₁₁	68 nF	C ₂₆	470 nF	R ₁₂	30 kΩ	R ₂₅	2 kΩ
C ₁₂	33 nF	C ₂₇	33 nF	R ₁₃	62 kΩ	R ₂₆	3.3 kΩ
C ₁₄	100 nF	C ₂₈	10 μF	R ₁₄	120 kΩ	R ₂₉	1 kΩ
C ₁₅	1 μF	R ₂	20 kΩ	R ₁₅	47 kΩ	R ₃₀	12 kΩ

Pin Description



12687

Figure 3. Pinning

Pin	Symbol	Function
1	G_T	A resistor from this pin to GND sets the amplification of microphone and DTMF signals; the input amplifier can be muted by applying V_{MP} to G_T .
2	DTMF	Input for DTMF signals. Also used for the answering machine and hands-free input.
3	MIC 2	Non-inverting input of microphone amplifier
4	MIC 1	Inverting input of microphone amplifier
5	IND	The internal equivalent inductance of the circuit is proportional to the value of the capacitor at this pin. A resistor connected to ground may be used to reduce the DC line voltage.
6	V_L	Line voltage
7	GND	Reference point for DC- and AC-output signals
8	SENSE	A small resistor (fixed) connected from this pin to V_L sets the slope of the DC characteristic and also affects the line-length equalization characteristics and the line current at which the loudspeaker amplifier is switched on.
9	V_B	Unregulated supply voltage for peripheral circuits (voice switch); limited to typically 7 V.
10	SAO	Output of loudspeaker amplifier
11	V_{MP}	Regulated supply voltage 3.3 V for peripheral circuits. The maximum output current is 2 mA.
12	IMPSEL	Control input for selection of line impedance 1. 600 Ω 2. 900 Ω 3. Mute of second transmit stage (TXA); also used for indication of external supply (answering machine); last chosen impedance is stored

Pin	Symbol	Function
13	TSACL	Time constant of anti-clipping of speaker amplifier
14	GSA	Current input for setting the gain of the speaker amplifier. Adjustment characteristic is logarithmical. For $RGSA > 2\text{ M}\Omega$, the speaker amplifier is switched off.
15	SA I	Speaker amplifier input (for loud-speaker, tone ringer and hands-free use)
16	MUTX	Three-state input of transmit mute: 1) Speech condition; inputs MIC1 / MIC2 active 2) DTMF condition; input DTMF active. A part of the input signal is passed to the receiving amplifier as a confidence signal during dialing. 3) Input DTMF used for answering machine and hands-free use; receive branch is not affected.
17	ATAFS	Attenuation of acoustical feedback suppression. Maximum attenuation of AFS circuit is set by a resistor at this pin. Without the resistor, AFS is switched off.
18	INLDT	Input of transmit level detector
19	INLDR	Input of receive level detector
20	TLDT	Time constant of transmit level detector
21	TLDR	Time constant of receive level detector

Pin	Symbol	Function
22	AGA	Automatic gain adjustment with line current. A resistor connected from this pin to GND sets the starting point. Max. gain change is 6 dB.
23	IREF	Internal reference current generation; $RREF = 62\text{ k}\Omega$; $IREF = 20\text{ }\mu\text{A}$
24	STO	Side-tone reduction output. Output resistance is approximately $300\text{ }\Omega$. Maximum load impedance is $10\text{ k}\Omega$.
25	V_M	Reference node for microphone-earphone and loudspeaker amplifier. Supply for electret microphone ($I_M \leq 300\text{ }\mu\text{A}$).
26	STI	Input for side-tone network
27	RECO	Output of receiving amplifier
28	G_R	A resistor connected from this pin to GND sets the receiving amplification of the circuit; amplifier RA1 can be muted by applying V_{MP} to G_R
29	TTXA	Time constant of anti-clipping in transmit path
30	RECIN	Input of receiving path; input impedance is typically $80\text{ k}\Omega$

DC Line Interface and Supply-Voltage Generation

The DC line interface consists of an electronic inductance and an output stage which charges the capacitor at V_B . The value of the equivalent inductance is given by:

$$L = R_{SENSE} \times C_{IND} \times (R_{DC} \times R_{30}) / (R_{DC} + R_{30})$$

In order to improve the supply during worst-case operating conditions, PNP current source $-I_{BOPT}$ –

supplies an extra amount of current to the supply voltages when the NPN in parallel is unable to conduct current.

The U4089B contains a series regulator which provides a supply voltage V_{MP} of 3.3 V at 2 mA suitable for a microprocessor.

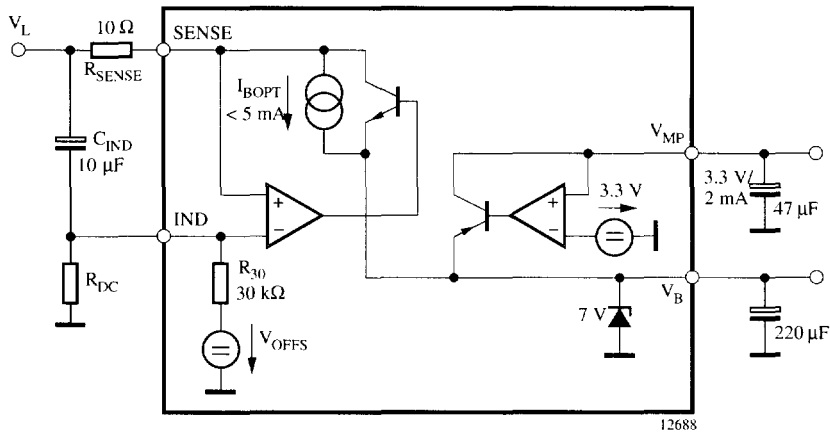

Figure 4. DC line interface with electronic inductance and generation of regulated and unregulated supply

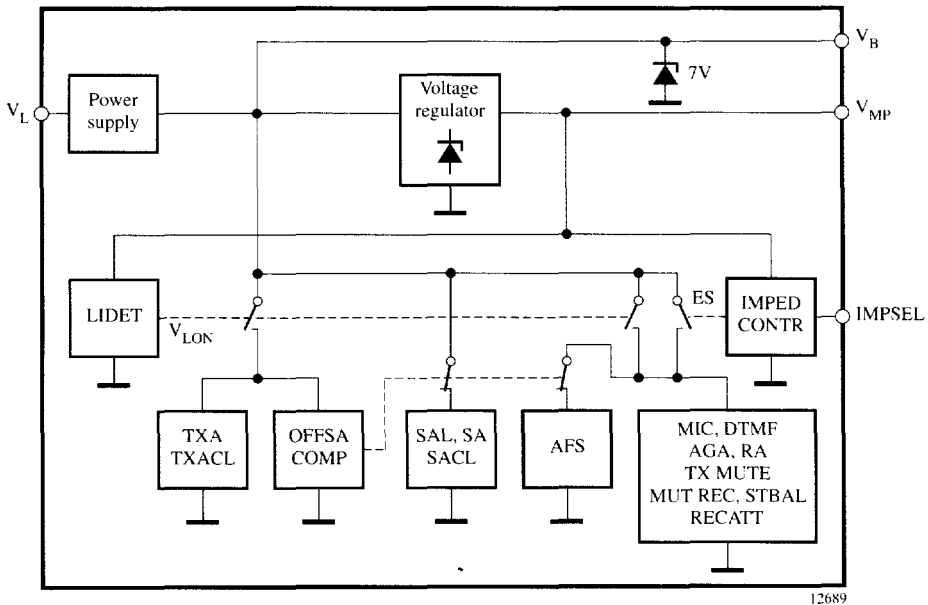

Figure 5. The supply of functional blocks is controlled by input voltages V_L , V_B

1. In speech condition, the system is supplied by the line current. If the LIDET-block detects a line voltage above the fixed threshold (1.9 V), the internal signal VLON is activated, thus switching on all blocks of the chip.

For line voltages below 1.9 V, the switches remain in their quiescent state as shown in the diagram.

OFFSACOMP disables the group listening feature (SAI, SA, SACL, AFS) below line currents of approximately 10 mA.

2. Selecting IMPSEL = high impedance activates all switches at the ES line.

Acoustic Feedback Suppression

Acoustical feedback from the loudspeaker to the handset microphone may cause instability in the system. The U4089B offers a very efficient feedback suppression

circuit which uses a modified voice switch topology. Figure 6 shows the basic system configuration.

Two attenuators (TX ATT and RX ATT) reduce the critical loop gain by introducing an externally adjustable amount of loss either in the transmit or in the receive path. The sliding control in block ATT CONTR determines whether the TX or the RX signal has to be attenuated. The overall loop gain remains constant under all operating conditions.

Selection of the active channel is made by comparison of the logarithmically compressed TX- and RX- envelope curve.

The system configuration for group listening, which is realized in the U4089B, is illustrated in figure 7. TXA and SAI represent the two attenuators; the logarithmic envelope detectors are shown in a simplified way (operational amplifiers with two diodes).

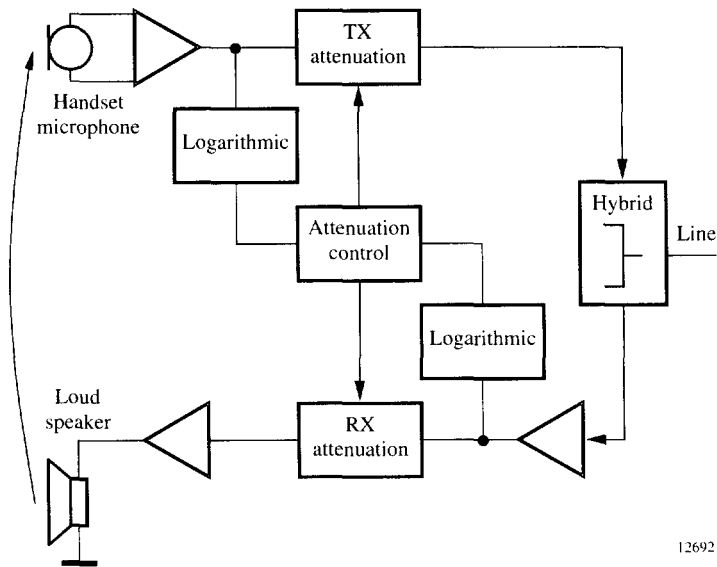

Figure 6. Basic voice-switch system

12692

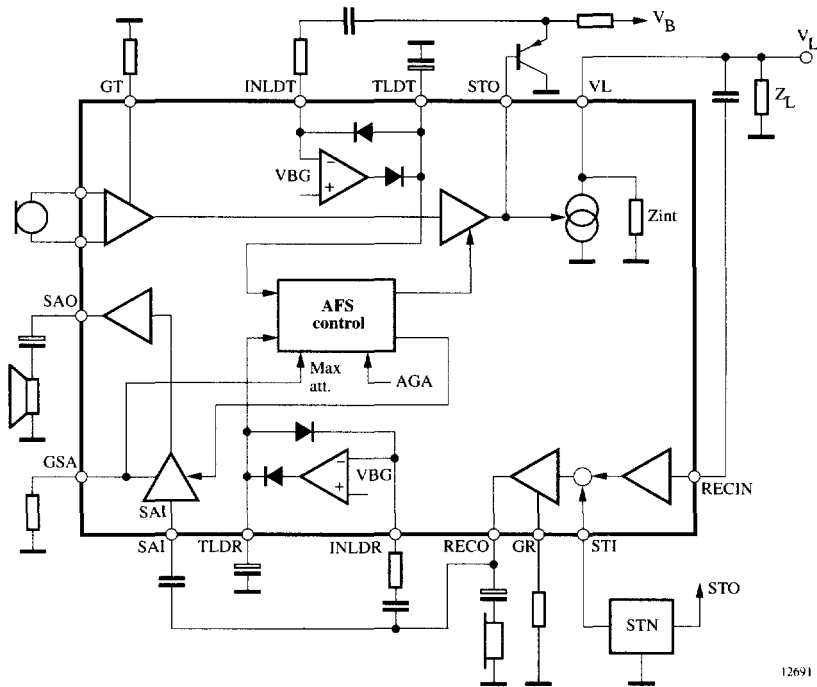

Figure 7. Integration of the acoustic feedback-suppression circuit into the speech circuit environment

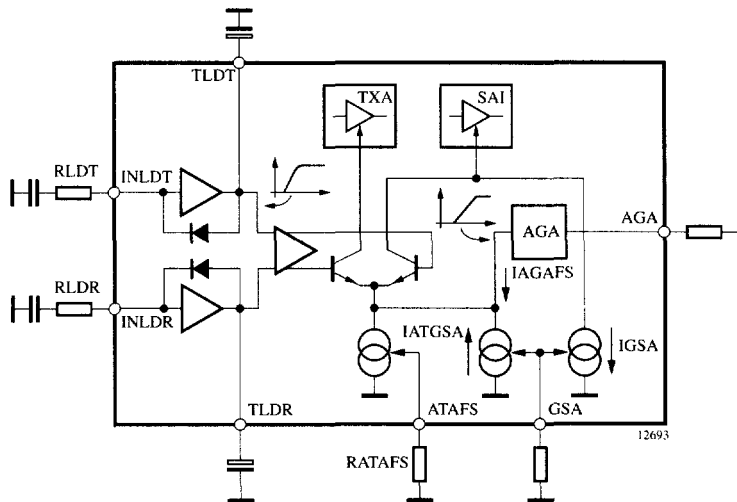

Figure 8. Acoustic feedback suppression by alternative control of transmit- and speaker amplifier gain

A detailed diagram of the AFS (acoustic feedback suppression) is given in figure 8. Receive and transmit signals are first processed by logarithmic rectifiers in order to produce the envelopes of the speech at TLDT and RLDT. After amplification, a decision is made by the differential pair which direction should be transmitted.

The attenuation of the controlled amplifiers TXA and SAI is determined by the emitter current I_{AT} which is comprised of three parts:

- I_{ATAFS} sets maximum attenuation
- I_{ATGSA} decreases the attenuation when speaker amplifier gain is reduced
- I_{AGAFS} decreases the attenuation according to the loop-gain reduction caused by the AGA-function

$$I_{AT} = I_{ATAFS} - I_{ATGSA} - I_{AGAFS}$$

$$\Delta G = I_{AT} \times 0.67 \text{ dB}/\mu\text{A}$$

Figure 11 illustrates the principal relationship between speaker amplifier gain (GSA) and attenuation of AFS (ATAFS). Both parameters can be adjusted independently, but the internal coupling between them has to be considered. The maximum value to be used of GSA is 36 dB. The shape of the characteristic is moved in the x-direction by adjusting resistor RATAFS, thus changing $ATAFS_m$. The actual value of the attenuation ($ATAFS_a$), however, can be determined by reading the value which belongs to the actual gain GSA_a . If the speaker amplifier gain is reduced, the attenuation of AFS is automatically reduced by the same amount in order to achieve a constant loop gain. Zero attenuation is set for speaker gains $GSA \leq GSA_0 = 36 \text{ dB} - ATAFS_m$.

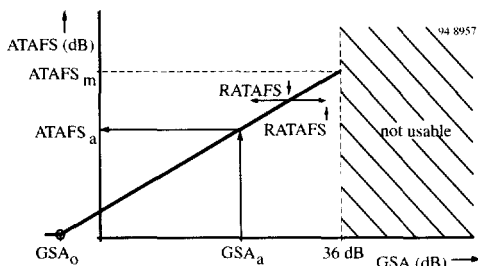

Figure 9. Reducing speaker amplifier gain results in an equal reduction of AFS attenuation

Operating Range of Speaker Amplifier

The basic behavior is illustrated in figure 10. Actual values of I_{LON}/I_{LOFF} vary slightly with the adjustment of the DC-characteristics and the selection of the internal line impedance.

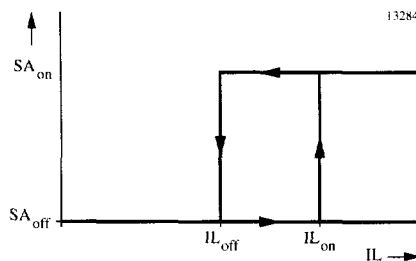
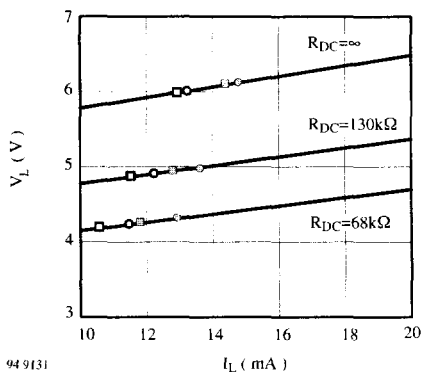

Figure 10. Threshold of speaker amplifier



- = I_{LON} at line impedance = 600 Ω
- = I_{LOFF} at line impedance = 600 Ω
- = I_{LON} at line impedance = 900 Ω
- = I_{LOFF} at line impedance = 900 Ω

Figure 11. Comparator thresholds depend on DC mask and line impedance

Absolute Maximum Ratings

Parameters	Symbol	Value	Unit
Line current	I_L	140	mA
DC line voltage	V_L	12	V
Junction temperature	T_j	125	°C
Ambient temperature	T_{amb}	-25 to +75	°C
Storage temperature	T_{stg}	-55 to +150	°C
Total power dissipation, $T_{amb} = 60^\circ\text{C}$	P_{tot}	1	W

Thermal Resistance

Parameters	Symbol	Value	Unit
Junction ambient SDIP30	R_{thJA}	50	K/W

Electrical Characteristics

$f = 1 \text{ kHz}$, $0 \text{ dBm} = 775 \text{ mV}_{\text{rms}}$, $I_M = 0.3 \text{ mA}$, $I_{MP} = 2 \text{ mA}$, $RDC = 130 \text{ k}\Omega$, $T_{amb} = 25^\circ\text{C}$, $RGSA = 560 \text{ k}\Omega$, $Z_{ear} = 68 \text{ nF} + 100 \text{ }\Omega$, $Z_M = 68 \text{ nF}$, Pin 20 open, $V_{MUTX} = \text{GND}$, unless otherwise specified.

Parameters	Test Conditions / Pin	Symbol	Min.	Typ.	Max.	Unit
DC characteristics						
DC voltage drop over circuit	$I_L = 2 \text{ mA}$ $I_L = 14 \text{ mA}$ $I_L = 60 \text{ mA}$ $I_L = 100 \text{ mA}$	V_L	4.6	2.4 5.0 7.5 9.4	5.4 10.0	V
Transmission amplifier, $I_L = 14 \text{ mA}$, $V_{MIC} = 2 \text{ mV}$, $RGT = 27 \text{ k}\Omega$, unless otherwise specified						
Adjustment range of transmit gain		G_T	40	45	50	dB
Transmitting amplification	$RGT = 12 \text{ k}\Omega$ $RGT = 27 \text{ k}\Omega$	G_T	47 39.8	48	49 41.8	dB
Frequency response	$I_L \geq 14 \text{ mA}$, $f = 300 \text{ to } 3400 \text{ Hz}$	ΔG_T			± 0.5	dB
Gain change with current	Pin 20 open $I_L = 14 \text{ to } 100 \text{ mA}$	ΔG_T			± 0.5	dB
Gain deviation	$T_{amb} = -10 \text{ to } +60^\circ\text{C}$	ΔG_T			± 0.5	dB
CMRR of microphone amplifier		CMRR	60	80		dB
Input resistance of MIC amplifier	$RGT = 12 \text{ k}\Omega$ $RGT = 27 \text{ k}\Omega$	R_i	45	50 75	110	$\text{k}\Omega$
Distortion at line	$I_L > 14 \text{ mA}$ $V_L = 700 \text{ mV}_{\text{rms}}$	d_t			2	%
Maximum output voltage	$I_L > 19 \text{ mA}$ $d < 5\%$ $V_{mic} = 25 \text{ mV}$ $CTXA = 1 \text{ }\mu\text{F}$	V_{Lmax}	1.8	3	4.2	dBm
Noise at line psophometrically weighted	$I_L > 14 \text{ mA}$ $G_T = 48 \text{ dB}$	no		-80	-72	dBmp
Anti-clipping attack time release time	$CTXA = 1 \text{ }\mu\text{F}$ each 3 dB overdrive			0.5 9		ms

Electrical Characteristics (continued)

Parameters	Test Conditions / Pin	Symbol	Min.	Typ.	Max.	Unit
Gain at low operating current	$I_L = 10 \text{ mA}$ $I_{MP} = 1 \text{ mA}$ $RDC = 68 \text{ k}\Omega$ $V_{mic} = 1 \text{ mV}$ $I_M = 300 \mu\text{A}$	G_T	40		42.5	dB
Distortion at low operating current	$I_L = 10 \text{ mA}$ $I_M = 300 \mu\text{A}$ $I_{MP} = 1 \text{ mA}$ $RDC = 68 \text{ k}\Omega$ $V_{mic} = 10 \text{ mV}$	d_l			5	%
Line-loss compensation	$I_L = 100 \text{ mA}$, $RAGA = 20 \text{ k}\Omega$	ΔG_{TI}	-6.4	-5.8	-5.2	dB
Mute suppression a) MIC muted (microphone preamplifier)	$I_L \geq 14 \text{ mA}$ $Mutx = \text{open}$	G_{TM}	60	80		dB
Receiving amplifier, $I_L = 14 \text{ mA}$, $RGR = 62 \text{ k}$, unless otherwise specified, $V_{GEN} = 300 \text{ mV}$						
Adjustment range of receiving gain	$I_L \geq 14 \text{ mA}$, single-ended	G_R	-8		+2	dB
Receiving amplification	$RGR = 62 \text{ k}\Omega$ $RGR = 22 \text{ k}\Omega$	G_R	-7.75	-7 1.5	-6.25	dB
Amplification of DTMF signal from DTMF IN to RECO	$I_L \geq 14 \text{ mA}$ $V_{MUTX} = V_{MP}$	G_{RM}	1	4	7	dB
Frequency response	$I_L > 14 \text{ mA}$, $f = 300 \text{ to } 3400 \text{ Hz}$	ΔG_{RF}			± 0.5	dB
Gain change with current	$I_L = 14 \text{ to } 100 \text{ mA}$	ΔG_R			± 0.5	dB
Gain deviation	$T_{amb} = -10 \text{ to } +60^\circ\text{C}$	ΔG_R			± 0.5	dB
Ear protection	$I_L \geq 14 \text{ mA}$ $V_{GEN} = 11 V_{rms}$	EP			1.1	V_{rms}
MUTE suppression DTMF operation	$I_L \geq 14 \text{ mA}$ $V_{MUTX} = V_{MP}$	ΔG_R	60			dB
Output voltage $d \leq 2\%$	$I_L = 14 \text{ mA}$ $Z_{ear} = 68 \text{ nF}$		0.5			V_{rms}
Maximum output current $d \leq 2\%$	$Z_{ear} = 100 \Omega$		4			mA (peak)
Receiving noise psophometrically weighted	$Z_{ear} = 68 \text{ nF} + 100 \Omega$ $I_L \geq 14 \text{ mA}$	ni		-80	-77	dBmp
Output resistance	Output against GND	R_o			10	Ω
Line-loss compensation	$RAGA = 20 \text{ k}\Omega$, $I_L = 100 \text{ mA}$	ΔG_{RI}	-7.0	-6.0	-5.0	dB
Gain at low operating current	$I_L = 10 \text{ mA}$ $I_{MP} = 1 \text{ mA}$ $I_M = 300 \mu\text{A}$ $V_{GEN} = 560 \text{ mV}$ $RDC = 68 \text{ k}\Omega$	G_R	-8	-7	-6	dB
AC impedance		Z_{imp}	840	900	960	Ω
Distortion at low operating current	$I_L = 10 \text{ mA}$ $I_{MP} = 1 \text{ mA}$ $V_{GEN} = 560 \text{ mV}$ $RDC = 68 \text{ k}\Omega$	dR			5	%

Electrical Characteristics (continued)

Parameters	Test Conditions / Pin	Symbol	Min.	Typ.	Max.	Unit
Speaker amplifier						
Minimum line current for operation	No ac signal	I_{Lmin}			15	mA
Input resistance	Pin 24		14		22	k Ω
Gain from SAI to SAO	$V_{SAI} = 3\text{ mV}$, $I_L = 15\text{ mA}$, $R_{GSA} = 560\text{ k}\Omega$ $R_{GSA} = 20\text{ k}\Omega$	G_{SA}	35.5	36.5 - 3	37.5	dB
Output power	Load resistance $R_L = 50\ \Omega$, $d < 5\%$ $V_{SAI} = 20\text{ mV}$ $I_L = 15\text{ mA}$ $I_L = 20\text{ mA}$	P_{SA} P_{SA}	3	7 20		mW
Output noise (input SAI open) psophometrically weighted	$I_L > 15\text{ mA}$	n_{SA}			200	μV_{psoph}
Gain deviation	$I_L = 15\text{ mA}$ $T_{amb} = -10\text{ to }+60^\circ\text{C}$	ΔG_{SA}			± 1	dB
Mute suppression	$I_L = 15\text{ mA}$, $V_L = 0\text{ dBm}$, $V_{SAI} = 4\text{ mV}$ Pin 23 open	VSAO			-60	dBm
Gain change with current	$I_L = 15\text{ to }100\text{ mA}$	ΔG_{SA}			± 1	dB
Resistor for turning off speaker amplifier	$I_L = 15\text{ to }100\text{ mA}$	R_{GSA}	0.8	1.3	2	M Ω
Gain change with frequency	$I_L = 15\text{ mA}$ $f = 300\text{ to }3400\text{ Hz}$	ΔG_{SA}			± 0.5	dB
Attack time of anti-clipping	20 dB over drive	t_r		5		ms
Release time of anti-clipping		t_f		80		ms
DTMF amplifier Test conditions: IMP = 2 mA, IM = 0.3 mA, $V_{MUTX} = VMP$						
Adjustment range of DTMF gain	$I_L = 15\text{ mA}$ Mute active	G_D	40		50	dB
DTMF amplification	$I_L = 15\text{ mA}$, $V_{DTMF} = 8\text{ mV}$ Mute active: $MUTX = VMP$	G_D	40.7	41.7	42.7	dB
Gain deviation	$I_L = 15\text{ mA}$ $T_{amb} = -10\text{ to }+60^\circ\text{C}$	G_D			± 0.5	dB
Input resistance	$R_{GT} = 27\text{ k}\Omega$ $R_{GT} = 15\text{ k}\Omega$	R_i	60 26	180 70	300 130	k Ω
Distortion of DTMF signal	$I_L \geq 15\text{ mA}$ $V_L = 0\text{ dBm}$	d_D			2	%
Gain deviation with current	$I_L = 15\text{ to }100\text{ mA}$	ΔG_D			± 0.5	dB
AFS acousting feedback suppression						
Range of attenuation	$I_L \geq 15\text{ mA}$		0		50	dB
Attenuation of transmit gain	$I_L \geq 15\text{ mA}$, $I_{INLDT} = 0\ \mu\text{A}$ $R_{ATAFS} = 30\text{ k}\Omega$ $I_{INLDR} = 10\ \mu\text{A}$	ΔG_T		45		dB

Electrical Characteristics (continued)

Parameters	Test Conditions / Pin	Symbol	Min.	Typ.	Max.	Unit
Attenuation of speaker amplifier	$I_L \geq 15 \text{ mA}$ $I_{INLDP} = 0 \mu$ $R_{ATAFS} = 30 \text{ k}\Omega$ $I_{INLDR} = 10 \mu$	ΔG_{SA}		50		dB
AFS disable	$I_L \geq 15 \text{ mA}$	V_{ATAFS}	1.5			V
Supply voltages, $V_{mic} = 25 \text{ mV}$, $T_{amb} = -10 \text{ to } +60^\circ\text{C}$						
V_{MP}	$I_L = 14 \text{ mA}$, RDC = 68 k Ω $I_{MP} = 2 \text{ mA}$	V_{MP}	3.1	3.3	3.5	V
V_M	$I_L \geq 14 \text{ mA}$, $I_M = 300 \mu\text{A}$ RDC = 130 k Ω	V_M	1.4		3.3	V
V_B	$I_B = +20 \text{ mA}$, $I_L = 0 \text{ mA}$	V_B		7	7.6	V
MUTX input						
Input current	$V_{MUTX} = V_{MP}$ $V_{MUTX} = \text{GND}$	I_{MUTX} I_{MUTX}		20 -20	30 -30	μA μA
Input voltage	Input high	V_{MUTX}	$V_{MP} - 0.3 \text{ V}$			V
	Input low	V_{MUTX}			0.3	V

U4089B Control

MUTX	MODE
0 MIC 1/2 transmit enabled receive enable AFS = on AGA = on TXACL = on	Speech
Z DTMF transmit enabled receive enable AFS = on AGA = on TXACL = on	For answering machine
1 DTMF transmit enabled DTMF to receive enable AFS = off AGA = off TXACL = off	DTMF dialling

IMPSEL	MODE
0 Line impedance = 600 Ω TXA = on ES = off	Speech
0 to Z Line impedance = 600 Ω TXA = off ES = on	Transmit mute
1 to Z Line impedance = 900 Ω TXA = off ES = on	Transmit mute
1 Line impedance = 900 Ω TXA = on ES = off	Speech

Logic-level

0 = < (0.3 V)
Z = > (1 V) < ($V_{MP} - 1 \text{ V}$) or (open input)
1 = > ($V_{MP} - 0.3 \text{ V}$)

AFS = Acoustical feedback-suppression control
AGA = Automatic gain adjustment
TXACL = Transmit anti-clipping control
ES = External supply

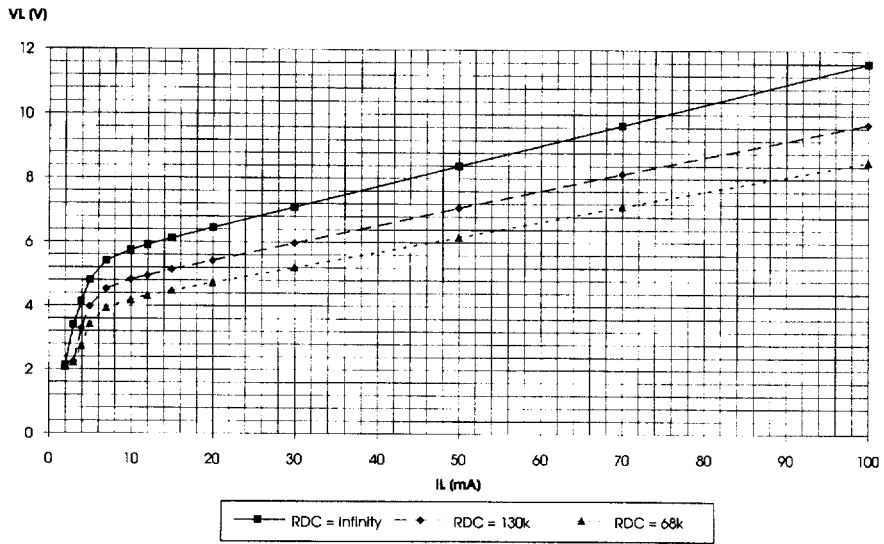

94 8856

Figure 12. Typical DC characteristic

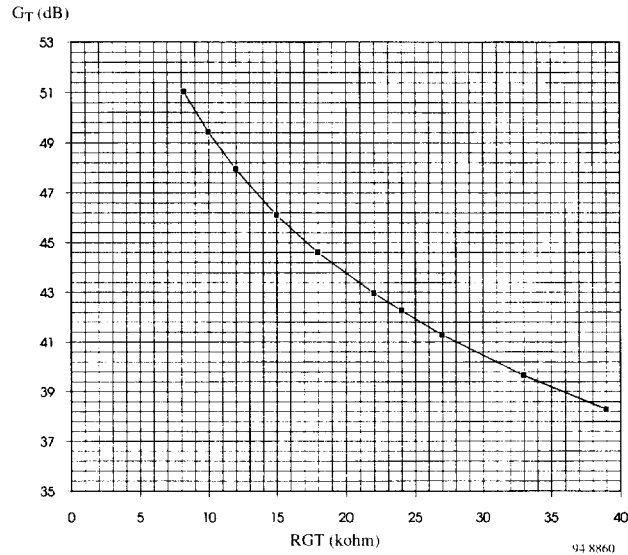

94 8860

Figure 13. Typical adjustment range of the transmit gain

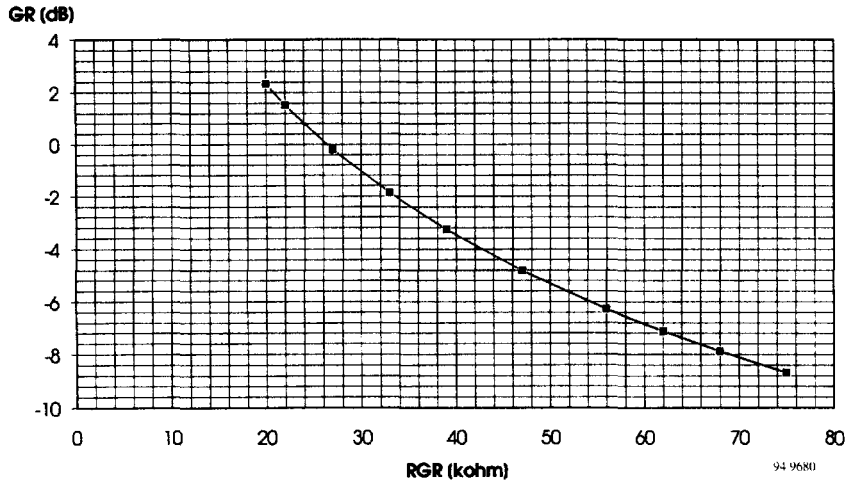

Figure 14. Typical adjustment range of the receive gain

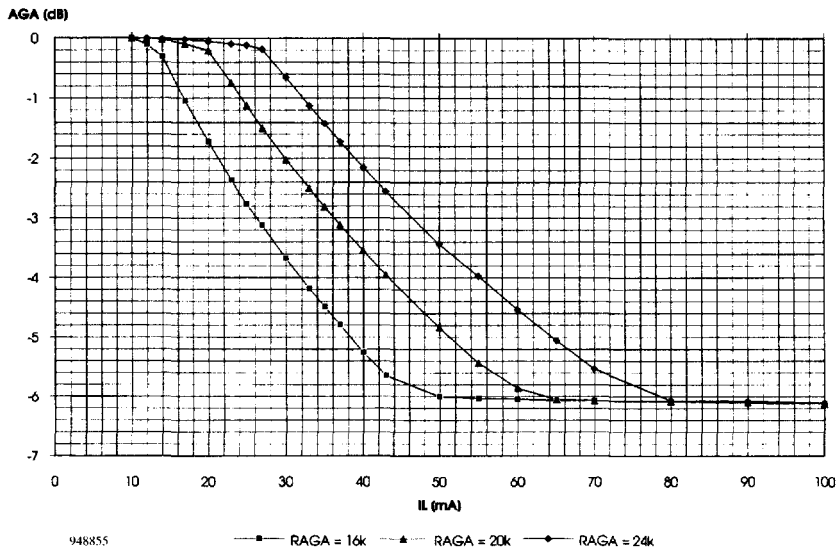

Figure 15. Typical AGA characteristic

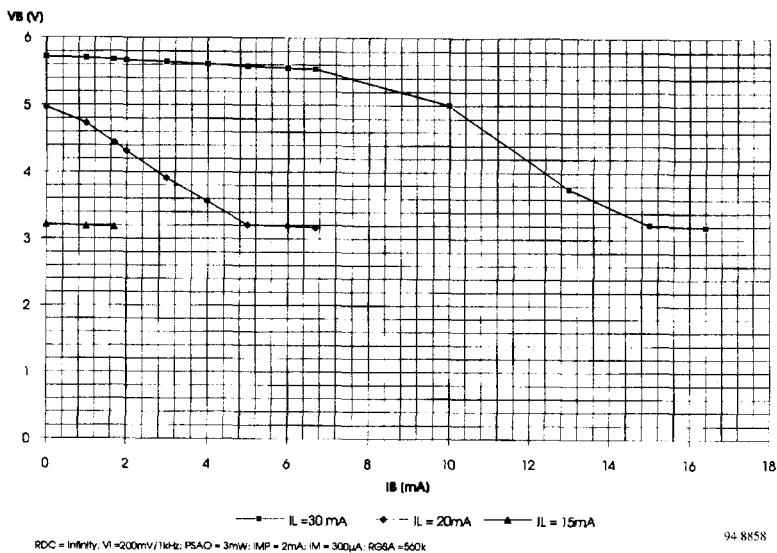

Figure 16. Typical load characteristic of V_B for a maximum (RDC = infinity) DC characteristic and a 3-mW loudspeaker output

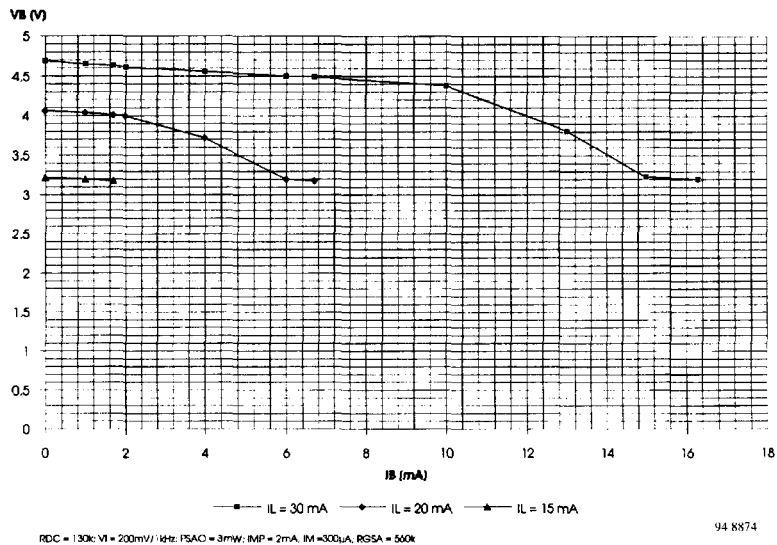

Figure 17. Typical load characteristic of V_B for a medium DC characteristic (RDC = 130 k Ω) and a 3-mW loudspeaker output

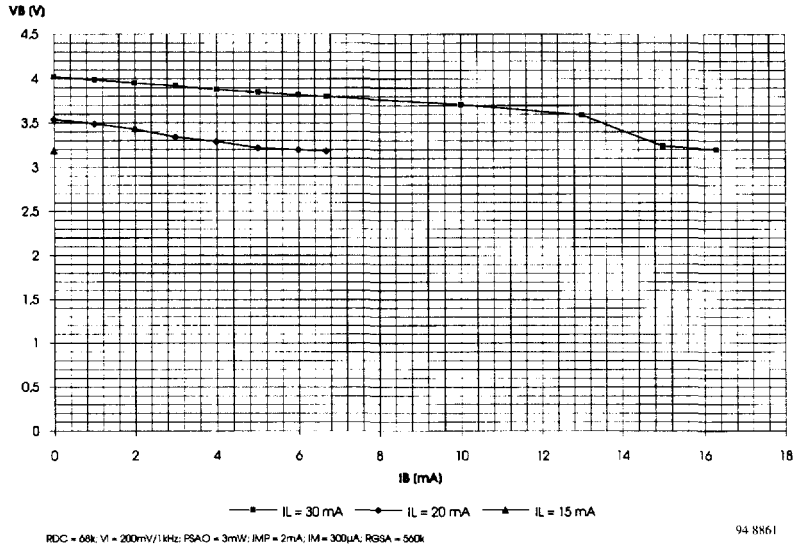
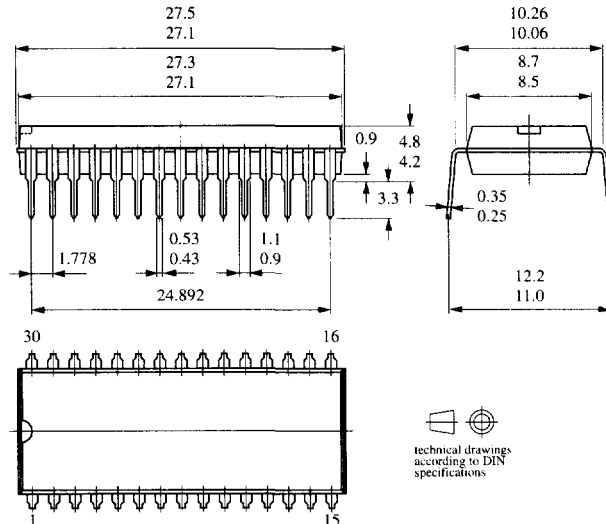

Figure 18. Typical load characteristic of V_B for a minimum DC characteristic (RDC = 68 k Ω) and a 3-mW loudspeaker output

Package Information

Package SDIP30

Dimensions in mm



13046