

# Tunable Multiprotocol XFP Optical Transceiver – 1550 nm for up to 80 km Reach

JXP Series



The Lumentum tunable 10 G multiprotocol optical XFP transceiver is an integrated fiber optic transceiver that provides a high-speed serial link at 9.95 to 11.35 Gbps signaling rates. The module complies with the 10 Gigabit small form factor pluggable (XFP) multisource agreement (MSA).

It complies with the ITU-T G.698.1 DN50S-2D2(C) standard with 50 GHz channel spacing for SONET/SDH, IEEE DWDM 10GBase-ZR for 80 km reach (Ethernet), and DWDM 10GFC for 80 km reach (Fibre Channel) applications.

The transceiver integrates the receive and transmit path on one module. On the transmit side, the 10 Gbps serial data stream is recovered, retimed, and passed to a modulator driver. The modulator driver biases and modulates a C-band-tunable integrated laser Mach-Zehnder (ILMZ), enabling data transmission over singlemode fiber through an industry-standard LC connector. On the receive side, the 10 Gbps optical data stream is recovered from an APD/transimpedance amplifier, retimed, and passed to an output driver. This module features a hot-pluggable XFI-compliant electrical interface.

#### Key Benefits

- Supports 9.953 Gbps (SONET and SDH); 10.31 Gbps (Ethernet); 10.52 Gbps (Fibre Channel); and corresponding 10.66, 10.709, 11.09, and 11.35 Gbps forward error correction (FEC) rates
- Monolithically integrated full C-band tunable transmitter
- 50 GHz ITU channel spacing with integrated wavelength locker
- Commercial operating temperature from -5 to 70°C
- 3.5 W maximum power dissipation
- No reference clock required
- Digital diagnostic monitoring support

#### Applications

- Wide, local, and storage area networks
- SONET OC-192 and SDH STM-64
- Ethernet and Fibre Channel switches

#### Compliance

- XFP MSA Revision 4.5
- SFF-8477
- RoHS 6/6
- Telcordia GR-253-CORE and tested in accordance with GR-468
- ITU-T G.691, G.698.1 DN50S-2D2(C)
- IEEE 802-3ae-2002
- 10 GFC 1200-SM-LL-L
- Class 1 laser safety

## Section 1 Functional Description

The JDSU tunable XFP optical transceiver is a full-duplex serial electric, serial optical device with both transmit and receive functions contained in a single module that provides a high-speed serial link at 9.95 to 11.35 Gbps signaling rates. It complies with the ITU-T G.698.1 DN50S-2D2(C) standard with 50 GHz ITU grid channel spacing for 80 km reach (SONET or SDH), IEEE 10GBase-ZR and 10GBase-ZW DWDM for 80 km reach (Ethernet), and 10GFC DWDM for 80 km reach (Fibre Channel) applications. The transceiver also fully complies with the 10 Gigabit small form factor XFP pluggable module multisource agreement INF8077i Rev. 4.5. A block diagram of the transceiver is shown in Figure 1.

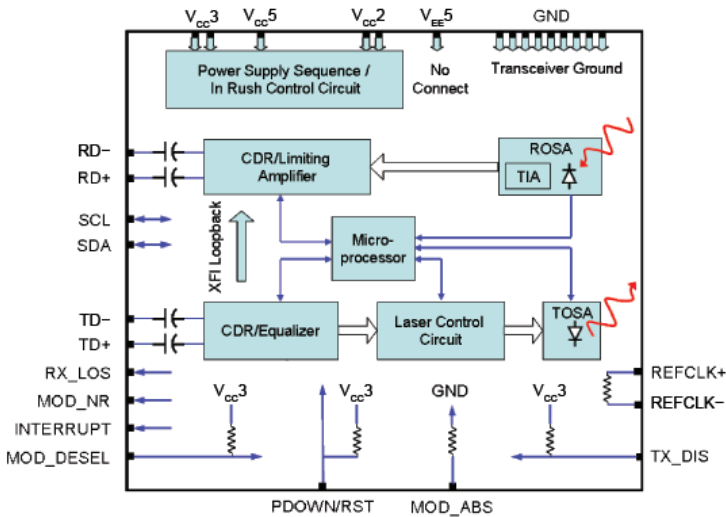

Figure 1. Functional block diagram

The transceiver locks to data without requiring a reference clock. The reference clock inputs have an internal AC-coupled 100 ohm differential line-to-line termination. It has several low-speed interface connections including a 2-wire serial interface. These connections include: module not ready (Mod\_NR), module deselect (Mod\_DeSel), interrupt, transmitter disable (TX\_DIS), module absent (Mod\_ABS), receive loss (RX\_LOS), and power down/reset (P\_Down/RST).

The transceiver also supports XFI system loopback. In this mode, data input on the electrical Tx pins of the XFP module is retimed and redirected to the module's Rx pin to facilitate system-side test and debug.

### Transmitter

The transmitter path converts serial NRZ electrical data from 9.95 to 11.35 Gbps line rates to a standard compliant optical signal. The transmitter accepts a 100 Ω differential 120 mV peak-to-peak to 820 mV peak-to-peak 10 Gbps CML electrical signal on TD- and TD+ pins.

Inside the module, the differential signals pass through a signal conditioner with equalization to compensate for the losses and deterministic jitter on the input data stream. The transmit CDR function generates a clock that is at the same frequency as the incoming electrical data input bit rate. The clock is phase aligned by a phase locked loop (PLL) that samples the data in the center of the data eye pattern. The CDR function does not require a reference clock to lock to incoming data, because it contains a lock detect circuit to indicate that the PLL has locked onto the incoming data.

The output of the Tx signal conditioner is input to the modulator driver which transforms the small-swing digital voltage to an output modulation that drives a cooled InP ILMZ modulator. The optical signal is engineered to meet the SONET/SDH, 10 Gigabit Ethernet, 10 G Fibre Channel, and corresponding FEC rates DWDM specifications at ITU grids with 50 GHz channel spacing. The unit provides closed-loop control of transmitted laser power, modulation swing, center wavelength over temperature, and voltage variations. The laser is coupled to single-mode optical fiber through an industry-standard LC optical connector.

### Receiver

The receiver converts incoming DC-balanced, serial NRZ optical data from 9.95 to 11.35 Gbps line rates into serial XFI electrical data. Light is coupled to an APD photodetector from single-mode optical fiber through an industry-standard LC optical connector. The electrical current from the APD photodetector is converted to a voltage in a transimpedance amplifier.

The amplified signal is passed to a signal-conditioning IC that provides clock and data recovery. The receive CDR function generates a clock that is at the same frequency as the incoming optical data input bit rate. The clock is phase aligned by a PLL that samples the data in the center of the data eye pattern. The CDR function does not require a reference clock to lock to incoming data. The CDR contains a lock detect circuit to indicate that the PLL has successfully locked onto the incoming data. Loss of signal and signal lock detection is included in the receive circuitry that is reflected in the Mod\_NR status pin. The recovered data is output on the RD+ and RD- pins as a 100 Ω 340 mV peak-to-peak CML signal. The output signal meets XFP MSA requirements.

### 1.3 Low-Speed Signaling

Low-speed signaling is based on low-voltage TTL (LVTTL) operating at a nominal voltage of 3.3 V.

SCL/SDA	2-wire serial interface clock and data line. Hosts should use a pull-up resistor connected to VCC 3.3 V on the 2-wire interface SCL (clock), SDA (data), and all low-speed outputs.
Mod_NR	Output pin. High indicates the module has detected a condition that renders Tx and/or Rx data invalid.
Mod_DeSel	Input pin. Low indicates the module responds to 2-wire serial communication commands. High indicates the module does not respond to or acknowledge any 2-wire interface communication from the host.
Interrupt	Output pin. Low indicates a possible module operational fault or a status critical to the host system.
TX_DIS	Input pin. High indicates the transmitter output is turned off.
Mod_ABS	Output pin. High indicates the XFP module is absent. It is pulled low when the XFP module is inserted.
RX_LOS	Output pin. High indicates insufficient optical power for reliable signal reception.
P_Down/RST	Multifunction input pin. The module can be powered down or reset by pulling the low-speed P-Down pin high. In power down mode, no data is transmitted on the optical Tx or the electrical Rx path. The reset pulse is generated on the falling edge of the P-Down signal. Following reset, the internal PLLs must reacquire lock and will temporarily indicate a Mod_NR failure until the PLLs reacquire lock.

## Section 2 Application Schematics

Recommended MSA connections to the transceiver are shown in Figure 2 on page 4.

Power supply filtering is recommended for the transceiver. To limit wideband noise power, the host system and module shall each meet a maximum of 2% peak-to-peak noise when measured with a 1 MHz low-pass filter. In addition, the host system and the module shall each meet a maximum of 3% peak-to-peak noise when measured with a filter from 1 to 10 MHz.

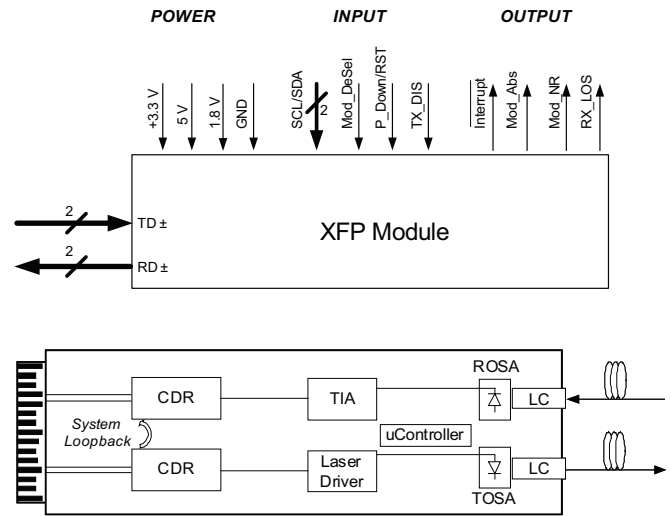

Figure 2. Application schematics

## Section 3 Specifications

Technical specifications related to the tunable 10 Gbps multiprotocol optical XFP transceiver include:

- Section 3.1 Pin Function Definitions
- Section 3.2 XFP/XFI Reference Model Compliance Points
- Section 3.3 Absolute Maximum Ratings
- Section 3.4 Operating Conditions
- Section 3.5 Electrical Characteristics
- Section 3.6 Jitter Specifications
- Section 3.7 XFP Two-Wire Interface Protocol and Management Interface
- Section 3.8 Optical Transmitter Characteristics
- Section 3.9 Optical Receiver Characteristics
- Section 3.10 Regulatory Compliance
- Section 3.11 PCB Layout
- Section 3.12 Module Outline
- Section 3.13 Connectors

### 3.1 Pin Function Definitions

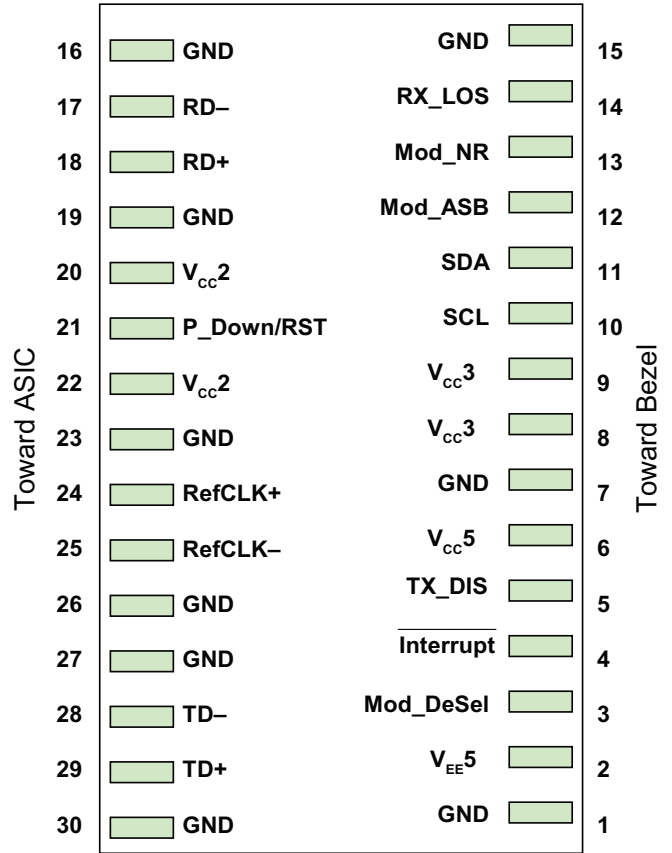

Figure 3. Transceiver pin assignments on host board

**Table 1. XFP Optical Transceiver Pin Descriptions**

Pin Number	Type	Name	Description
1		GND <sup>1</sup>	Module ground
2		V <sub>EE</sub> 5	Not used; may be left unconnected (optional -5.2 V power supply).
3	LVTTL-I	Mod_Desel	Module de-select: when held low, allows the module to respond to 2-wire serial interface commands.
4	LVTTL-O	Interrupt <sup>2</sup>	Interrupt: indicates presence of an important condition which can be read over the serial 2-wire interface.
5	LVTTL-I	TX_DIS	Transmitter disable: transmitter laser source turned off
6		VCC5	+5 V power supply
7		GND <sup>1</sup>	Module ground
8		V <sub>CC</sub> 3	+3.3 V power supply
9		V <sub>CC</sub> 3	+3.3 V power supply
10	LVTTL-I	SCL <sup>2</sup>	2-wire interface clock
11	LVTTL-I/O	SDA <sup>2</sup>	2-wire interface data line
12	LVTTL-O	Mod_Abs <sup>2</sup>	Indicates module is not present. Connected to ground with 302 Ω resistor.
13	LVTTL-O	Mod_NR <sup>2</sup>	Module not ready: indicating module operational fault
14	LVTTL-O	RX_LOS <sup>2</sup>	Receiver loss of signal indicator
15		GND <sup>1</sup>	Module ground
16		GND <sup>1</sup>	Module ground
17	CML-O	RD-	Receiver inverted data output
18	CML-O	RD+	Receiver noninverted data output
19		GND <sup>1</sup>	Module ground
20		V <sub>CC</sub> 2	+1.8 V power supply
21	LVTTL-I	P_Down/RST	Power down; when high, the module limits power consumption to 1.5 W or below. Serial interface is functional in the low power mode. Reset: the falling edge initiates a complete reset of the module including the serial interface, equivalent to a power cycle.
22		V <sub>CC</sub> 2	+1.8 V power supply
23		GND <sup>1</sup>	Module ground
24	PECL-I	RefCLK+	Reference clock noninverted input (not used)
25	PECL-I	RefCLK-	Reference clock inverted input (not used)
26		GND <sup>1</sup>	Module ground
27		GND <sup>1</sup>	Module ground
28	CML-I	TD-	Transmitter inverted data input
29	CML-I	TD+	Transmitter noninverted data input
30		GND <sup>1</sup>	Module ground

1. Module ground pins (GND) are isolated from the module case and chassis ground within the module.

2. Shall be pulled up with 4.7 – 10 kΩ to a voltage between 3.15 V and 3.45 V on the host board.

### 3.2 XFP/XFI Reference Model Compliance Points

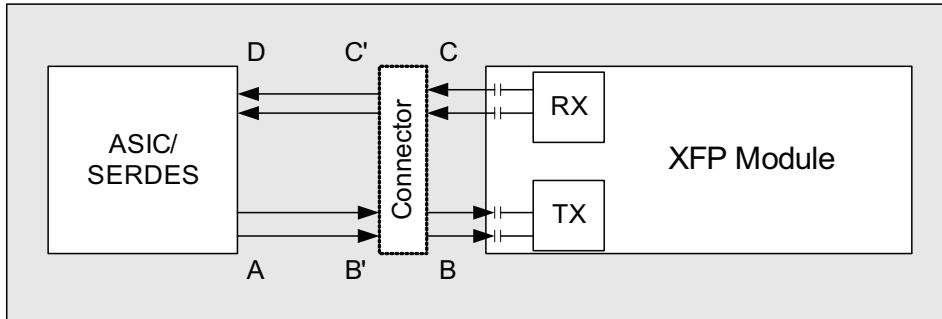

Figure 4. XFP/XFI reference model compliance points

### 3.3 Absolute Maximum Ratings

Absolute maximum ratings represent the device's damage thresholds. Damage may occur if the device is operated above the limits stated here except for brief excursions. Performance is not guaranteed and reliability is not implied for operation at any condition outside the recommended operating limits.

Parameter	Symbol	Ratings	Unit
Storage temperature	$T_{ST}$	-40 to +85	°C
Operating case temperature	$T_{OP}$	-5 to +70	°C
Relative humidity	RH	5 to 85 (noncondensing)	%
Static electrical discharge (Human Body Model)	ESD	500	V
Power supply voltages	$V_{CC2, max}$ $V_{CC3, max}$ $V_{CC5, max}$	-0.3 to 1.98 -0.3 to 3.63 -0.5 to 6.0	V V V
Receive input optical power (damage threshold)	$P_{dth}$	+3	dBm

### 3.4 Operating Conditions

Performance is not guaranteed and reliability is not implied for operation at any condition outside the recommended operating limits.

Part Number	Chromatic Dispersion (-400 ps/nm)	Chromatic Dispersion (1600 ps/nm)	Commercial Temperature (-5°C – 70°C)
JXP01TMAC1CX5***	X	X	X

### 3.5 Electrical Characteristics

Parameter	Symbol	Minimum	Typical	Maximum	Unit	Notes
<b>Supply currents and voltages</b>						
Voltage3	$V_{cc3}$	3.13	3.3	3.47	V	With respect to GND
Voltage5	$V_{cc5}$	4.75	5	5.25	V	With respect to GND
Voltage2	$V_{cc2}$	1.71	1.8	1.89	V	With respect to GND
Supply current3	$I_{cc3}$			750	mA	3.3 V
Supply current5	$I_{cc5}$			500	mA	5.0 V
Supply current2	$I_{cc2}$			1000	mA	1.8 V
Power dissipation	Pwr			3.5	W	
<b>Low speed control and sense signals (detailed specification in XFP MSA INF8077i Rev. 4.5)</b>						
Outputs (Interrupt, Mod_NR, RX_LOS)	$V_{OL}$	0		0.4	V	$R_{pullup}$ pulled to host $V_{cc}$ , measured at host side of connector. $I_{OL} (max)=3$ mA
	$V_{OH}$	host $V_{cc} - 0.5$		host $V_{cc} + 0.3$	V	$R_{pullup}$ pulled to host $V_{cc}$ , measured at host side of connector.
Inputs (TX_DIS, P_Down/RST, M_DSEL)	$V_{IL}$	-0.3		0.8	V	Pulled up in module to $V_{cc3}$
	$V_{IH}$	2		$V_{cc3} + 0.3$	V	Pulled up in module to $V_{cc3}$
SCL and SDA inputs	$V_{IL}$	-0.3		$V_{cc3} * 0.3$		$R_{pullup}$ pulled to host $V_{cc}$ , measured at XFP side of connector.
	$V_{IH}$	$V_{cc3} * 0.7$		$V_{cc3} + 0.5$		$R_{pullup}$ pulled to host $V_{cc}$ , measured at XFP side of connector.
<b>Transmitter input (detailed specification in XFP MSA INF8077i Rev. 4.5)</b>						
Data input baud rate nominal		9.95		11.35	Gbps	
Data input bit rate tolerance (10GbE/10GFC)		-100		+100	ppm	
Data input bit rate tolerance (SONET/SDH)		-20		+20	ppm	
Data input compliance			B			Internally AC-coupled signals
Data input differential impedance	$R_i$	90	100	110	$\Omega$	
<b>Receiver output (detailed specification in XFP MSA INF8077i Rev. 4.5)</b>						
Data output baud rate nominal		9.95		11.35	Gbps	
Data output compliance			C			Internally AC-coupled signals
Data output bit rate stability (10GbE / 10GFC)		-100		+100	ppm	
Data output bit rate stability (SONET/SDH)		-20		+20	ppm	

### 3.6 Jitter Specifications

Parameter	Symbol	Min	Max	Unit	Notes
<b>Transmitter electrical input jitter from host at B (detailed specification in XFP MSA INF8077i Rev. 4.5)</b>					
Total non-EQJ jitter			0.41	UI <sub>(D-P)</sub>	Total jitter less ISI
Total jitter	TJ		0.61	UI <sub>(D-P)</sub>	
Eye mask	X1		0.305	UI	Mask coordinate X1=0.205 if total non-DDJ is measured.
Eye mask	Y1	60		mV	
Eye mask	Y2		410	mV	50 mV is allocated for multiple reflections.
<b>Receiver electrical output jitter to host at C (detailed specification in XFP MSA INF8077i Rev. 4.5)</b>					
Deterministic jitter	DJ		0.18	UI <sub>(D-P)</sub>	Includes jitter transferred from the optical receiver during any valid operational input condition.
Total jitter	TJ		0.34	UI <sub>(D-P)</sub>	Includes jitter transferred from the optical receiver during any valid operational input condition.
Eye mask	X1		0.17	UI	
Eye mask	X2		0.42	UI	
Eye mask	Y1	170		mV	
Eye mask	Y2		425	mV	
Jitter transfer bandwidth	BW		8	MHz	PRBS 2 <sup>31</sup> -1, OC-192 / SDH-64 Sinusoidal jitter tolerance mask
Jitter peaking			1	dB	Frequency >120 KHz
Transmitter jitter generation			0.3 0.1	UI <sub>pp</sub> UI <sub>pp</sub>	20 KHz to 80 MHz 4 MHz to 80 MHz

### 3.7 XFP Two-Wire Interface Protocol and Management Interface

The transceiver incorporates an XFP-compliant, 2-wire management interface which is used for serial ID, digital diagnostics, and certain control functions. It is modeled on the SFF-8472 Rev 9.3 specification modified to accommodate a single 2-wire interface address. In addition to the basic I2C read/write functionality, the modules support packet error checking that, when enabled, allows the host system to confirm the validity of any read data. Details of the protocol and interface are explicitly described in the MSA. Please refer to the MSA for design reference.

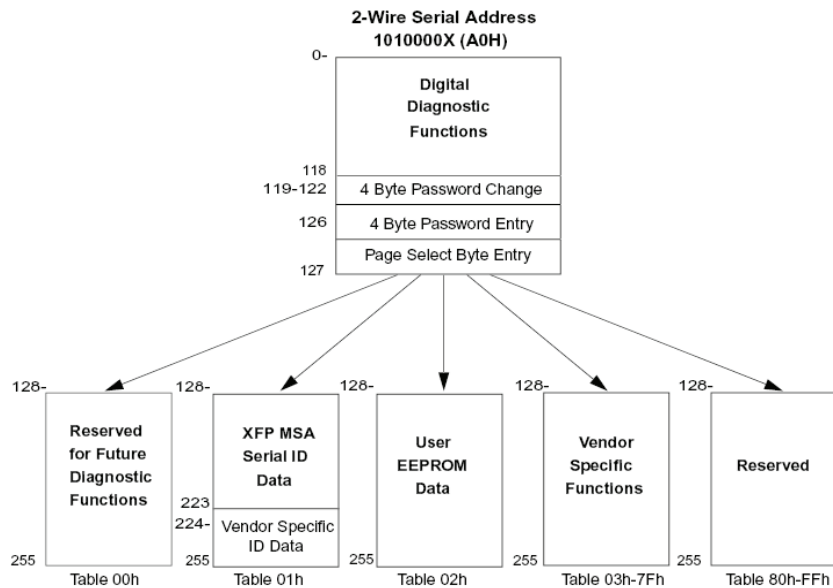

Figure 5. XFP 2-wire serial digital diagnostic memory map

### 3.8 Optical Transmitter Characteristics

Parameter	Symbol	Minimum	Typical	Maximum	Unit
Average optical power (EOL)	$P_{avg}$	-1.0		3.0	dBm
Extinction ratio <sup>1</sup>	ER	9			dB
Wavelength range <sup>2</sup>	$\lambda_c$	1528.384		1568.773	nm
Frequency range <sup>3</sup>		191.1		196.15	THz
Channel spacing		50			GHz
Frequency stability (BOL)		$f_c-1.5$	$f_c$	$f_c+1.5$	GHz
Frequency stability (EOL)		$f_c-2.5$	$f_c$	$f_c+2.5$	GHz
Channel tuning time <sup>4</sup>				50	ms
Side-mode suppression ratio	SMSR	35			dB
Relative intensity noise	RIN			-130	dB/Hz
Return loss tolerance				27	dB

Note:

Specifications are applicable to the operating temperature range listed in Section 3.4.

1. Tested with PRBS 2<sup>31</sup>-1 pattern
2. ITU grid wavelength
3. ITU grid frequency
4. Any channel to any channel

### 3.9 Optical Receiver Characteristics

Parameter	Symbol	Minimum	Typical	Maximum	Unit
Center wavelength	$\lambda$	1260		1600	nm
Receiver sensitivity (EOL) <sup>1</sup>					
Back to back (0 ps/nm)	$R_{sen}$			-24	dBm
Fiber (-400 to 1600 ps/nm)	$R_{sensf}$			-21.5	dBm
Receive overload <sup>2</sup>	$P_{max}$	-7			dBm
Receiver reflectance	$R_{rx}$			-27	dB
LOS assert	$P_{los\_on}$	-33.5		-28	dBm
LOS deassert	$P_{los\_off}$	-33		-26	dBm
LOS hysteresis		0.5		4	dB

Note:

Specifications are applicable to the operating temperature range listed in Section 3.4.

1. Guaranteed at 10.709 Gbps. Measured with worst ER; BER<10<sup>-12</sup>; PRBS 2<sup>31</sup>-1 pattern.
2. Guaranteed up to 10.709 Gbps.

### 3.10 Regulatory Compliance

The Lumentum Tunable Multiprotocol XFP Optical Transceiver is RoHS 6/6 compliant and complies with international electromagnetic compatibility (EMC) and product safety requirements and standards.

**Table 2. Regulatory Compliance**

Feature	Test Method	Performance
<b>Safety</b>		
Product safety	UL 60950-1	UL recognized component for US and CAN
	CSA C22.2 No. 60950-1	
	EN 60950-1	TUV certificate
	IEC 60950-1	CB certificate
	Flame class V-0	Passes Needle Flame Test for component flammability verification
	Low Voltage Directive 2014/35/EU	Certified to harmonized standards listed; Declaration of Conformity issued
Laser safety	EN 60825-1, EN 60825-2	TUV certificate
	IEC 60825-1, IEC 60825-2	CB certificate
	U.S. 21 CFR 1040.10	FDA/CDRH certified with accession number
<b>Electromagnetic compatibility</b>		
Radiated emissions	EMC Directive 2014/30/EU	Class B digital device with a minimum -6dB margin to the limit. Final margin may vary depending on system implementation. Tested frequency range: 30 MHz to 40 GHz or 5th harmonic (5 times the highest frequency), whichever is less. Good system EMI design practice is required to achieve Class B margins at the system level.
	FCC rules 47 CFR Part 15	
	CISPR 22, CISPR32	
	AS/NZS CISPR22, CISPR32	
	EN 55022, EN 55032	
	ICES-003, Issue 6	
	VCCI regulations	
Immunity	EMC Directive 2014/30/EU	Certified to harmonized standards listed; Declaration of Conformity issued
	CISPR 24	
	EN 55024	
ESD	IEC/EN 61000-4-2	Exceeds Requirements. Withstands discharges of ±8kV contact, ±15kV air
Radiated immunity	IEC/EN 61000-4-3	Exceeds Requirements. Field strength of 10V/m from 80 MHz to 6 GHz. No effect on transmitter / receiver performance is detectable between these limits.
<b>Restriction of hazardous substances (ROHS)</b>		
RoHS	EU Directive 2011/65/EU	Compliant per the Directive 2011/65/EU of the European Parliament and of the Council of 8 June 2011 on the restriction of the use of certain hazardous substances in electrical and electronic equipment (recast). A RoHS Certificate of Compliance (C of C) is available upon request. The product may use certain RoHS exemptions..

### 3.11 PCB Layout

Recommended PCB layout is given in XFP MSA INF8077i Rev. 4.5.

### 3.12 Module Outline

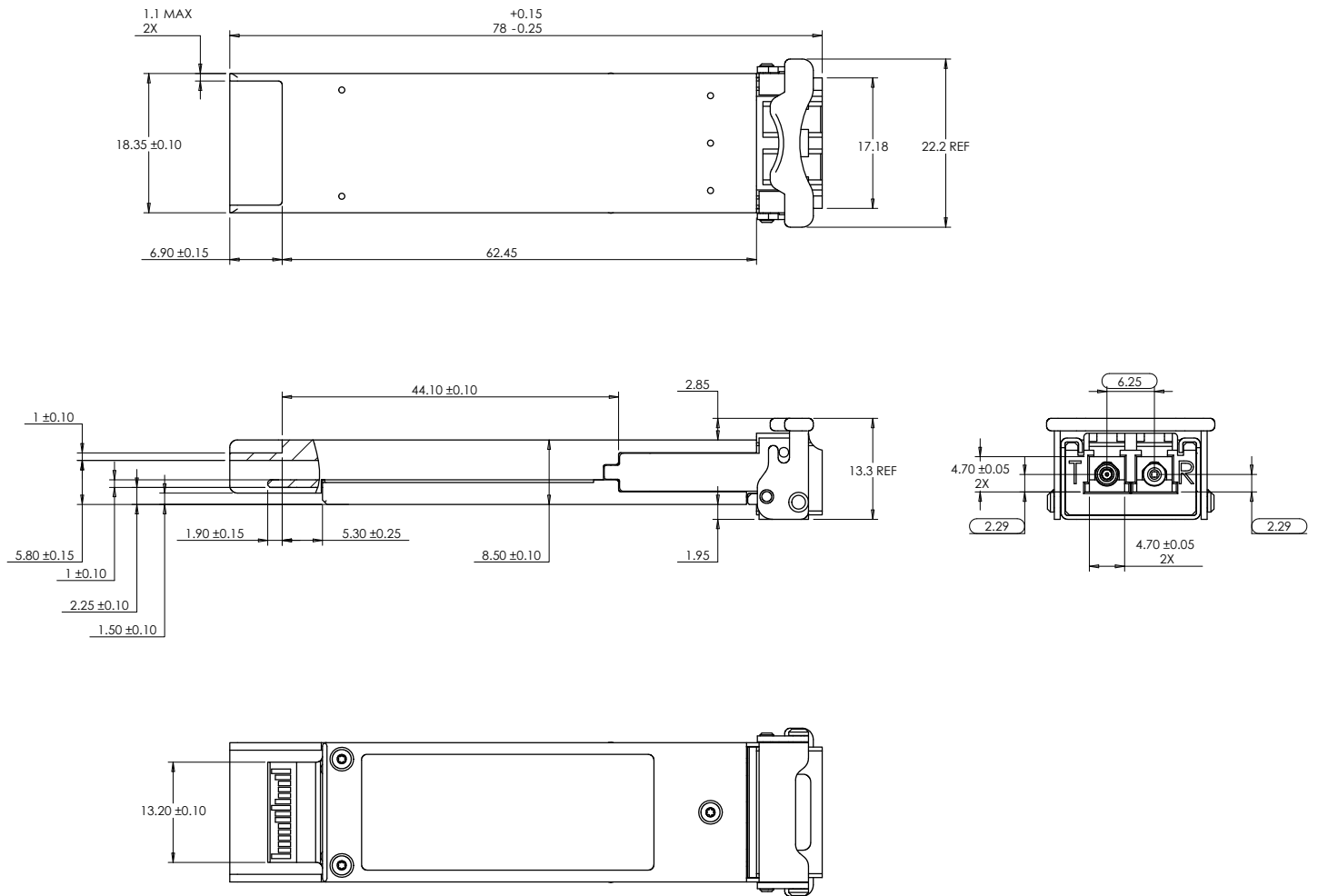

Figure 6. Belly-to-belly mounting recommendation

### 3.13 Connectors

#### Fiber

The XFP module has a duplex LC receptacle connector.

#### Electrical

The electrical connector is the 30-way, two-row PCB edge connector. The customer connector is Tyco/AMP Part No. 788862C or equivalent.

## Section 4 Related Information

Other information related to the transceiver includes:

Section 4.1 Packing and Handling Instructions

Section 4.2 Electrostatic Discharge (ESD)

Section 4.3 Laser Safety

### 4.1 Package and Handling Instructions

#### Connector Covers

The transceiver is supplied with an LC duplex receptacle. The connector plug supplied protects the connector during standard manufacturing processes and handling by preventing contamination from dust, aqueous solutions, body oils, and airborne particles.

Note: It is recommended that the connector plug remain on whenever the transceiver optical fiber connector is not inserted.

#### Recommended Cleaning and Degreasing Chemicals

Lumentum recommends the use of methyl, isopropyl and isobutyl alcohols for cleaning.

Do not use halogenated hydrocarbons like trichloroethane or ketones such as acetone, chloroform, ethyl acetate, MEK, methylene chloride, methylene dichloride, phenol, or N-methylpyrrolidone.

This product is not designed for aqueous wash.

#### Housing

The transceiver housing is made from zinc.

### 4.2 Electrostatic Discharge (ESD)

#### Handling

Normal electrostatic discharge (ESD) precautions are required during the handling of this module. This transceiver is shipped in ESD protective packaging. It should be removed from the packaging and otherwise handled in an ESD protected environment utilizing standard grounded benches, floor mats, and wrist straps.

#### Test and Operation

In most applications, the optical connector will protrude through the system chassis and be subjected to the same ESD environment as the system. Once properly installed in the system, this transceiver should meet and exceed common ESD testing practices and fulfill system ESD requirements.

Typical of optical transceivers, this module's receiver contains a highly sensitive optical detector and amplifier which may become temporarily saturated during an ESD strike. This could result in a short burst of bit errors. Such an event might require that the application re-acquire synchronization at the higher layers (for example, via a serializer/deserializer chip).

### 4.3 Laser Safety

The transceiver is certified as a Class 1 laser product per international standard IEC 60825-1:2014 3rd edition and is considered non-hazardous when operated within the limits of this specification. This device complies with 21 CFR 1040.10 except for deviations pursuant to Laser Notice No. 50.



#### Caution

Operating this product in a manner inconsistent with intended usage and specifications may result in hazardous radiation exposure.

Use of controls or adjustments or performance of procedures other than these specified in this product data sheet may result in hazardous radiation exposure.

Tampering with this laser product or operating this product outside the limits of this specification may be considered an "act of manufacturing" and may require recertification of the modified product.

Viewing the laser output with certain optical instruments (for example, eye loupes, magnifiers, microscopes) within a distance of 100 mm may pose an eye hazard.

### Ordering Information

For more information on this or other products and their availability, please contact your local Lumentum account manager or Lumentum directly at [customer.service@lumentum.com](mailto:customer.service@lumentum.com).

Product Code	Description
JXP01TMAC1CX5GE2	Transceiver module (generic) - 10 G XFP LR-2 DWDM 50 GHz C-band tunable multirate commercial temperature, RoHS6.
JXP01TMAC1CX5***	Transceiver module (customized) - 10 G XFP LR-2 DWDM 50 GHz C-band tunable multirate commercial temperature, RoHS6. * indicates a customer-specific alphanumeric character provided by Lumentum prior to sale.



North America  
Toll Free: 844 810 LITE (5483)

Outside North America  
Toll Free: 800 000 LITE (5483)

China  
Toll Free: 400 120 LITE (5483)

© 2016 Lumentum Operations LLC  
Product specifications and descriptions in this document are subject to change without notice.