



DATA SHEET

O K I A S I C P R O D U C T S

Z0166
USB 2.0 Device Controller APB Wrapper
Virtual Component Soft IP

August 2002

Oki Semiconductor

USB 2.0 Device Controller APB Wrapper

Functional Overview

Oki's Z0166 APB Wrapper for USB 2.0 Device Controller is designed to manage the control and data flow between USB 2.0 Device Controller and ARM® APB (Advanced Peripheral Bus) Bridge. It provides all the necessary logic to manage the transmission and reception of the USB data by decoding the APB protocol and USB 2.0 Device Controller (UDC20) application interface protocol.

Features

- USB 2.0 Device controller Rev 1.2b compliant
- Supports both Full speed (12 MHz) and High speed (480 MHz)
- Supports Isochronous, bulk and control transfers
- Supports four transmit FIFOs (one 64 Byte, two 512 bytes and one 2 kBytes)
- Supports four receive FIFOs (one 64 Byte, two 512 bytes and one 2 kBytes)
- Supports one control endpoint and six additional endpoints
- Customizable to specific application's requirement.

Target Application

USB applications requiring the AMBA™ (APB) ARM standard interface.



Block Diagram

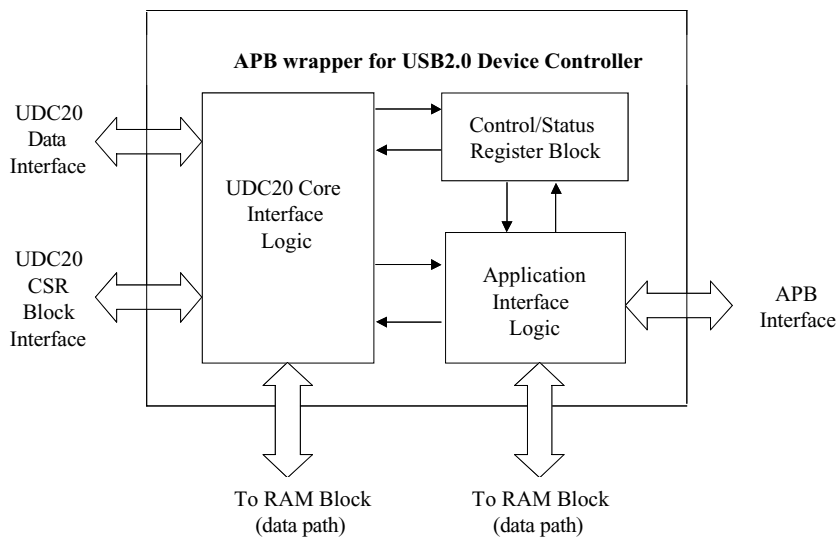

Performance

Operating Conditions

Parameter	0.25 μm Technology			Units
	Min	Typ	Max	
Power Supply Voltage	2.25	2.5	2.75	V
Junction Temperature	-40	25	125	°C
Clock Frequency	-	-	30	MHz

Estimated Gate Count

Estimated Gate Count		
Parameter	0.25 μm	Units
Gate Count	12.29	KG
Logic Pin Count	460	

The information contained herein can change without notice owing to product and/or technical improvements.

Please make sure before using the product that the information you are referring to is up-to-date.

The outline of action and examples of application circuits described herein have been chosen as an explanation of the standard action and performance of the product. When you actually plan to use the product, please ensure that the outside conditions are reflected in the actual circuit and assembly designs.

Oki assumes no responsibility or liability whatsoever for any failure or unusual or unexpected operation resulting from misuse, neglect, improper installation, repair, alteration or accident, improper handling, or unusual physical or electrical stress including, but not limited to, exposure to parameters outside the specified maximum ratings or operation outside the specified operating range.

Neither indemnity against nor license of a third party's industrial and intellectual property right, etc. is granted by us in connection with the use of product and/or the information and drawings contained herein. No responsibility is assumed by us for any infringement of a third party's right which may result from the use thereof.

When designing your product, please use our product below the specified maximum ratings and within the specified operating ranges, including but not limited to operating voltage, power dissipation, and operating temperature.

The products listed in this document are intended for use in general electronics equipment for commercial applications (e.g., office automation, communication equipment, measurement equipment, consumer electronics, etc.). These products are not authorized for use in any system or application that requires special or enhanced quality and reliability characteristics nor in any system or application where the failure of such system or application may result in the loss or damage of property or death or injury to humans. Such applications include, but are not limited to: traffic control, automotive, safety, aerospace, nuclear power control, and medical, including life support and maintenance.

Certain parts in this document may need governmental approval before they can be exported to certain countries. The purchaser assumes the responsibility of determining the legality of export of these parts and will take appropriate and necessary steps, at their own expense, for export to another country.

AMBA and the ARM powered logo are trademarks, and ARM is a registered trademark of Advanced RISC Machines, Ltd.

Copyright 2002 Oki Semiconductor

Oki Semiconductor reserves the right to make changes in specifications at anytime and without notice. This information furnished by Oki Semiconductor in this publication is believed to be accurate and reliable. However, no responsibility is assumed by Oki Semiconductor for its use; nor for any infringements of patents or other rights of third parties resulting from its use. No license is granted under any patents or patent rights of Oki.



Oki REGIONAL SALES OFFICES

Silicon Solutions

Northwest Area

785 N. Mary Avenue
Sunnyvale, CA 94085
Tel: 408/720-8940
Fax: 408/720-8965

Southwest Area

San Diego, CA
Tel: 760/214-6512
760/214-6414
Fax: 408/737-6568
408/737-6567

Northeast Area

Shattuck Office Center
138 River Road
Andover, MA 01810
Tel: 978/688-8687
Fax: 978/688-8896

South Central Area

Park Creek II
2007 N. Collins Blvd., Suite 305
Richardson, TX 75080
Tel: 972/238-5450
Fax: 972/238-0268

Oki Web Site:

<http://www.okisemi.com/us>

Oki Stock No: 320323-001

Oki Semiconductor

Corporate Headquarters

785 N. Mary Avenue
Sunnyvale, CA 94085-2909
Tel: 408/720-1900
Fax: 408/720-1918