

RED INDICATES ORIGINAL

TABLE 1

DASH NO	CONN TYPE	IMPD (OHMS)	MATERIAL	ASSEMBLE PER
-1	PL220	50	1-0442-016	TAI-A118
-2	CJ220		1-0443-016	
-3	PL240		1-0445-016	
-4	CJ240		1-0445-016	
-5	BJ226		1-0472-016	TAI-123
-6	BJ229		1-0473-016	
-7	BJ246		1-0046-016	
-8	BJ249		1-0047-016	
-9	UPL220	75	1-0468-016	TAI-D118
-10	UPL240		1-0041-016	
-11	PL223	50	1-0009-016	TAI-A118
-12	UPL223	75	1-0050-016	TAI-D118
-13	PL240S	50	1-0446-016	TAI-A118
-14	UPL240S		1-0041-016	TAI-D118
-15	UBJ229	75	1-0488-016	TAI-123
-16	UCJ220		1-0494-016	TAI-D118
-17	UCJ240		1-0496-016	
-18	UBJ226		1-0489-016	TAI-123
-19	UPLR220		1-0504-016	TAI-221
-20	UPLFF220		1-0517-016	TAI-223
-21	UBJ220		1-0515-016	TAI-D118

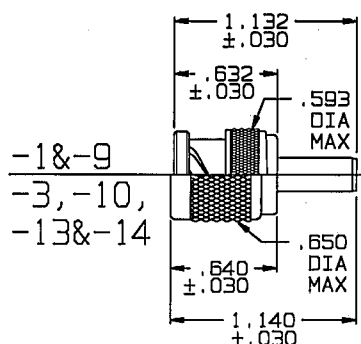

REVISIONS			105-1171	SH
REV	ED	DESCRIPTION	DWN	APPROVED
A	12703	UPDATED DRAWING SEE ECD	R. L.	MM. 3/2/99

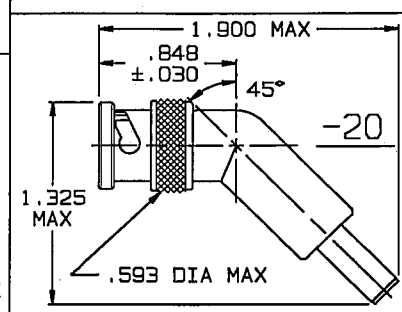
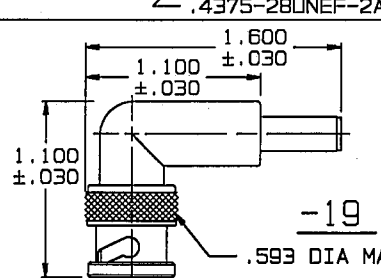
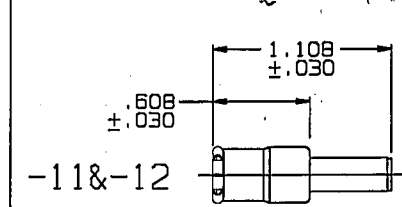
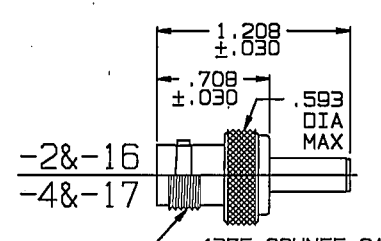

CENTER CONTACT CRIMP TOOLING

CONTACT TYPE	MILITARY 8 POINT INDENTER	COMMERCIAL HEX	COMMERCIAL 8 POINT INDENTER
50 OHM PIN CONTACT	M22520/1-01 BASIC TOOL WITH M22520/1-12 TURRET HEAD SELECTOR NO. 6	TEI CT4L BASIC TOOL WITH TEI CD3-3 DIE, CLOSURE C (.068 HEX)	N/A
50 OHM SOCKET CONTACT	M22520/1-01 BASIC TOOL WITH M22520/1-12 TURRET HEAD SELECTOR NO. 6	TEI CT4L BASIC TOOL WITH TEI CD3-3 DIE, CLOSURE C (.068 HEX)	N/A
75 OHM PIN CONTACT	N/A	TEI CT4L BASIC TOOL WITH TEI CD3-3 DIE, CLOSURE D (.042 HEX)	TEI 010-0055
75 OHM SOCKET CONTACT	N/A	TEI CT4L BASIC TOOL WITH TEI CD3-3 DIE, CLOSURE D (.042 HEX)	TEI 010-0088

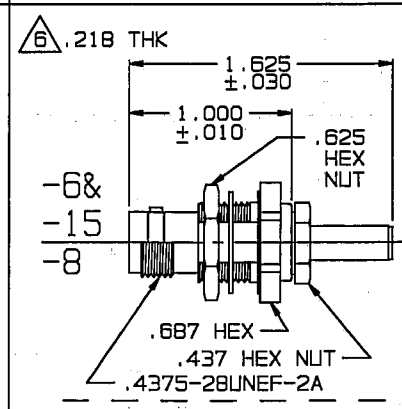
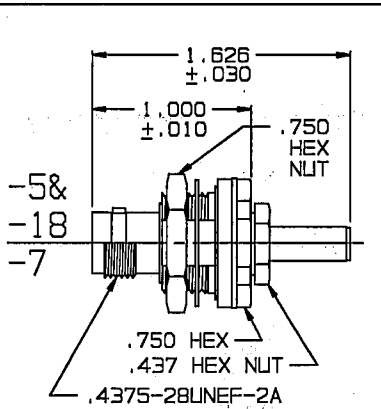

CRIMP SLEEVE TOOLING

CONNECTOR TYPE	MILITARY HEX	COMMERCIAL HEX
50 OR 75 OHM CONNECTORS	M22520/5-01 BASIC TOOL WITH M22520/5-33 DIE, CLOSURE A (.344 HEX)	TEI CT4L BASIC TOOL WITH TEI CD3-3 DIE, CLOSURE A (.344 HEX)

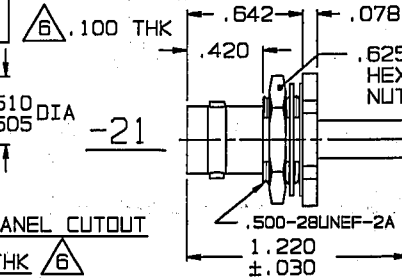
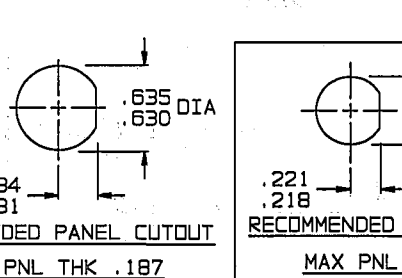

4. EXAMPLE OF COMPLETE PART NO:

105-1171 - 1
 BASIC PART NO. DASH NO
 (SEE TABLE 1)

3. 50 & 75 OHM FULL CRIMP COAXIAL BNC/TNC CABLE PLUGS/ RECEPTACLE/INSULATED & NONINSULATED BULKHEAD MOUNT CABLE RECEPTACLE/PUSH-ON PLUG & 75 OHM BNC/TNC/PUSH-ON FULL CRIMP COAXIAL CABLE PLUG FOR W.E.C.D CABLE NO. 728B

2. FINISH: TFS-1A (NICKEL)

1. ALL DIM ARE IN INCHES

REPLACE CRIMP SLEEVE 8-1613-7 WITH CRIMP SLEEVE 8-1613-8

TOL UNLESS SPECIFIED	XXX ± .005
XXX ± .0005	XXX ± .0005
XXX ± .0002	XXX ± .0002
XXX ± .0001	XXX ± .0001

TROMPETER ELECTRONICS, INC.		220/240 SERIES-728B	
DWN	R. L.	2/24/99	MATERIAL
CHK		2-15-99	CODE IDENT
ENGR			14949
APPR	MM.	3/11/99	DRAWING NO.
			105-1171
			REV
			A

NEXT ASSY	APPR	MM.	3/11/99	SCALE	DATE	5/5/88	SHEET
-----------	------	-----	---------	-------	------	--------	-------