



Async/Page/Burst CellularRAM™ 1.5 Memory

MT45W4MW16BKGB

Features

- Single device supports asynchronous, page, and burst operations
- VCC, VCCQ voltages:
 - 1.7–1.95V VCC
 - 1.7–3.6V VCCQ¹
- Random access time: 70ns
- Burst mode READ and WRITE access
 - 4, 8, 16, or 32 words or continuous burst
 - Burst wrap or sequential
 - MAX clock rate: 133 MHz¹ (t_{CLK} = 7.5ns)
 - Burst initial latency: 37.5ns (5 clocks) at 133 MHz
 - t_{ACLK}: 5.5ns at 133 MHz
- Page mode read access
 - Sixteen-word page size
 - Interpage read access: 70ns
 - Intrapage read access: 20ns
- Low power consumption
 - Asynchronous READ: <25mA
 - Intrapage READ: <15mA
 - Initial access, burst READ: (37.5ns [5 clocks] at 133 MHz): 45mA
 - Continuous burst READ: 40mA
 - Standby: 180µA
 - Deep power-down: 10µA
- Low-power features
 - On-chip temperature-compensated refresh (TCR)
 - Partial-array refresh (PAR)
 - Deep power-down (DPD) mode

Figure 1: Ball Assignment 54-Ball VFBGA

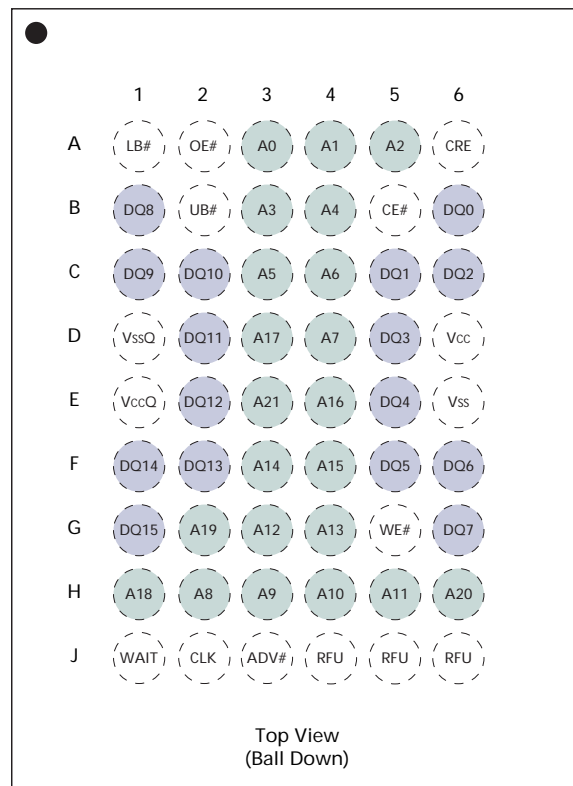

Options

- Configuration: 4 Meg x 16
 - VCC core voltage supply: 1.7–1.95V
 - VCCQ I/O voltage supply: 1.7–3.6V¹
- Package
 - 54-ball VFBGA (“green”)
- Access time
 - 70ns
- Frequency
 - 133 MHz
 - 104 MHz
 - 80 MHz

Designator

MT45W4MW16BK
GB
-70
13
1
8

Options (Continued)

- Standby power at +85°C
 - Standard: 180µA (MAX)
 - Low-power: 140µA (MAX)
- Operating temperature range
 - Wireless (–30°C to +85°C)
 - Industrial (–40°C to +85°C)

Designator

None
L
WT
IT

Notes: 1. The 3.6V I/O and 133 MHz clock rate exceed the CellularRAM 1.5 Workgroup specifications.

Part Number Example:

MT45W4MW16BKGB-701WT



Table of Contents

Features	1
General Description	5
Part-Numbering Information	9
Valid Part Number Combinations	9
Device Marking	9
Functional Description	10
Power-Up Initialization	10
Bus Operating Modes	10
Asynchronous Mode	10
Page Mode READ Operation	12
Burst Mode Operation	12
Mixed-Mode Operation	14
WAIT Operation	14
LB#/UB# Operation	15
Low-Power Operation	17
Standby Mode Operation	17
Temperature-Compensated Refresh (TCR)	17
Partial-Array Refresh (PAR)	17
Deep Power-Down Operation (DPD)	17
Registers	17
Access Using CRE	18
Software Access	22
Bus Configuration Register (BCR)	24
Refresh Configuration Register	31
Device Identification Register	33
Electrical Characteristics	34
Timing Requirements	38
Timing Diagrams	42
Package Information	69
Revision History	70



List of Figures

Figure 1:	Ball Assignment 54-Ball VFBGA	1
Figure 2:	Functional Block Diagram – 4 Meg x 16	6
Figure 3:	Part Number Chart	9
Figure 4:	Power-Up Initialization Timing	10
Figure 5:	READ Operation (ADV# LOW)	11
Figure 6:	WRITE Operation (ADV# LOW)	11
Figure 7:	Page Mode READ Operation (ADV# LOW)	12
Figure 8:	Burst Mode READ (4-word Burst)	13
Figure 9:	Burst Mode WRITE (4-word Burst)	14
Figure 10:	Wired-OR WAIT Configuration	15
Figure 11:	Refresh Collision During Variable-Latency READ Operation	16
Figure 12:	Configuration Register WRITE, Asynchronous Mode Followed by READ ARRAY	18
Figure 13:	Configuration Register WRITE, Synchronous Mode Followed by READ ARRAY Operation	19
Figure 14:	Register READ, Asynchronous Mode Followed by READ ARRAY Operation	20
Figure 15:	Register READ, Synchronous Mode Followed by READ ARRAY Operation	21
Figure 16:	Load Configuration Register	22
Figure 17:	Read Configuration Register	23
Figure 18:	Bus Configuration Register Definition	24
Figure 19:	WAIT Configuration (BCR[8] = 0)	27
Figure 20:	WAIT Configuration (BCR[8] = 1)	28
Figure 21:	WAIT Configuration During Burst Operation	28
Figure 22:	Latency Counter (Variable Initial Latency, No Refresh Collision)	29
Figure 23:	Latency Counter (Fixed Latency)	30
Figure 24:	Refresh Configuration Register Mapping	31
Figure 25:	Typical Refresh Current vs. Temperature (ITCR)	36
Figure 26:	AC Input/Output Reference Waveform	37
Figure 27:	AC Output Load Circuit	37
Figure 28:	Initialization Period	42
Figure 29:	DPD Entry and Exit Timing	42
Figure 30:	Asynchronous READ	43
Figure 31:	Asynchronous READ Using ADV#	44
Figure 32:	Page Mode READ	45
Figure 33:	Single-Access Burst READ Operation – Variable Latency	46
Figure 34:	4-Word Burst READ Operation – Variable Latency	47
Figure 35:	Single-Access Burst READ Operation – Fixed Latency	48
Figure 36:	4-Word Burst READ Operation – Fixed Latency	49
Figure 37:	READ Burst Suspend	50
Figure 38:	Burst READ at End-of-Row (Wrap Off)	51
Figure 39:	CE#-Controlled Asynchronous WRITE	52
Figure 40:	LB#/UB#-Controlled Asynchronous WRITE	53
Figure 41:	WE#-Controlled Asynchronous WRITE	54
Figure 42:	Asynchronous WRITE Using ADV#	55
Figure 43:	Burst WRITE Operation – Variable Latency Mode	56
Figure 44:	Burst WRITE Operation – Fixed Latency Mode	57
Figure 45:	Burst WRITE at End of Row (Wrap Off)	58
Figure 46:	Burst WRITE Followed by Burst READ	59
Figure 47:	Burst READ Interrupted by Burst READ or WRITE	60
Figure 48:	Burst WRITE Interrupted by Burst WRITE or READ – Variable Latency Mode	61
Figure 49:	Burst WRITE Interrupted by Burst WRITE or READ – Fixed Latency Mode	62
Figure 50:	Asynchronous WRITE Followed by Burst READ	63
Figure 51:	Asynchronous WRITE (ADV# LOW) Followed by Burst READ	64
Figure 52:	Burst READ Followed by Asynchronous WRITE (WE#-Controlled)	65
Figure 53:	Burst READ Followed by Asynchronous WRITE Using ADV#	66
Figure 54:	Asynchronous WRITE Followed by Asynchronous READ – ADV# LOW	67
Figure 55:	Asynchronous WRITE Followed by Asynchronous READ	68
Figure 56:	54-Ball VFBGA	69



List of Tables

Table 1:	VFBGA Ball Descriptions	7
Table 2:	Bus Operations – Asynchronous Mode (BCR[15] = 1; Default)	8
Table 3:	Bus Operations – Burst Mode (BCR[15] = 0)	8
Table 4:	Sequence and Burst Length	26
Table 5:	Drive Strength	27
Table 6:	Variable Latency Configuration Codes (BCR [14] = 0)	29
Table 7:	Fixed Latency Configuration Codes (BCR[14] = 1)	30
Table 8:	64Mb Address Patterns for PAR (RCR[4] = 1)	32
Table 9:	Device Identification Register Mapping	33
Table 10:	Absolute Maximum Ratings	34
Table 11:	Electrical Characteristics and Operating Conditions	35
Table 12:	Operating Conditions	35
Table 13:	Partial-Array Refresh Specifications and Conditions	36
Table 14:	Deep Power-Down Specifications	36
Table 15:	Capacitance	37
Table 16:	Asynchronous READ Cycle Timing Requirements	38
Table 17:	Burst READ Cycle Timing Requirements	39
Table 18:	Asynchronous WRITE Cycle Timing Requirements	40
Table 19:	Burst WRITE Cycle Timing Requirements	41
Table 20:	Initialization Timing Parameters	42



General Description

Micron® CellularRAM™ products are high-speed, CMOS memory developed for low-power, portable applications. The MT45W4MW16BKGB is a 64Mb DRAM core device, organized as 4 Meg x 16 bits. This device includes an industry-standard burst mode Flash interface that dramatically increases read/write bandwidth compared with other low-power SRAM or Pseudo SRAM offerings.

To operate seamlessly on a burst Flash bus, CellularRAM products incorporate a transparent self refresh mechanism. The hidden refresh requires no additional support from the system memory controller and has no significant impact on device read/write performance.

Two user-accessible control registers define device operation. The bus configuration register (BCR) defines how the CellularRAM device interacts with the system memory bus and is nearly identical to its counterpart on burst mode Flash devices. The refresh configuration register (RCR) is used to control how refresh is performed on the DRAM array. These registers are automatically loaded with default settings during power-up and can be updated anytime during normal operation.

Special attention has been focused on standby current consumption during self refresh. CellularRAM products include three mechanisms to minimize standby current. Partial-array refresh (PAR) enables the system to limit refresh to only that part of the DRAM array that contains essential data. Temperature-compensated refresh (TCR) uses an on-chip sensor to adjust the refresh rate to match the device temperature—the refresh rate decreases at lower temperatures to minimize current consumption during standby. Deep power-down (DPD) enables the system to halt the refresh operation altogether when no vital information is stored in the device. The system configurable refresh mechanisms are accessed through the RCR.

This CellularRAM device is compliant with the industry-standard CellularRAM 1.5 feature set established by the CellularRAM Workgroup. It includes support for both variable and fixed latency, with three output-device drive-strength settings, additional wrap options, and a device ID register (DIDR).



64Mb: 4 Meg x 16 Async/Page/Burst CellularRAM 1.5 Memory General Description

Figure 2: Functional Block Diagram – 4 Meg x 16

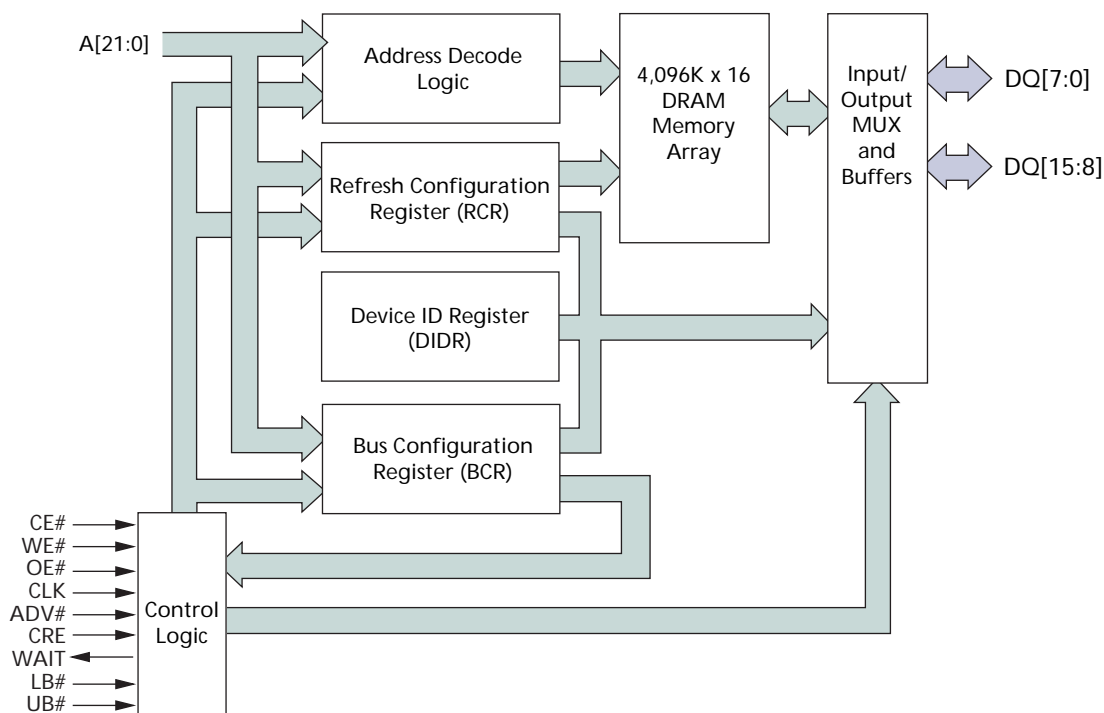

Notes: 1. Functional block diagrams illustrate simplified device operation. See ball descriptions in Table 1 on page 7; bus operations in Tables 2 and 3 on page 8; and timing diagrams starting on page 42, for detailed information.



64Mb: 4 Meg x 16 Async/Page/Burst CellularRAM 1.5 Memory General Description

Table 1: VFBGA Ball Descriptions

VFBGA Assignment	Symbol	Type	Description
E3, H6, G2, H1, D3, E4, F4, F3, G4, G3, H5, H4, H3, H2, D4, C4, C3, B4, B3, A5, A4, A3	A[21:0]	Input	Address inputs: Inputs for addresses during READ and WRITE operations. Addresses are internally latched during READ and WRITE cycles. The address lines are also used to define the value to be loaded into the BCR or the RCR.
J2	CLK	Input	Clock: Synchronizes the memory to the system operating frequency during synchronous operations. When configured for synchronous operation, the address is latched on the first rising CLK edge when ADV# is active. CLK must be static LOW during asynchronous access READ and WRITE operations and during PAGE READ ACCESS operations.
J3	ADV#	Input	Address valid: Indicates that a valid address is present on the address inputs. Addresses can be latched on the rising edge of ADV# during asynchronous READ and WRITE operations. ADV# can be held LOW during asynchronous READ and WRITE operations.
A6	CRE	Input	Control register enable: When CRE is HIGH, WRITE operations load the RCR or BCR, and READ operations access the RCR, BCR, or DIDR.
B5	CE#	Input	Chip enable: Activates the device when LOW. When CE# is HIGH, the device is disabled and goes into standby or deep power-down mode.
A2	OE#	Input	Output enable: Enables the output buffers when LOW. When OE# is HIGH, the output buffers are disabled.
G5	WE#	Input	Write enable: Determines if a given cycle is a WRITE cycle. If WE# is LOW, the cycle is a WRITE to either a configuration register or to the memory array.
A1	LB#	Input	Lower byte enable. DQ[7:0]
B2	UB#	Input	Upper byte enable. DQ[15:8]
G1, F1, F2, E2, D2, C2, C1, B1, G6, F6, F5, E5, D5, C6, C5, B6	DQ[15:0]	Input/output	Data inputs/outputs.
J1	WAIT	Output	Wait: Provides data-valid feedback during burst READ and WRITE operations. The signal is gated by CE#. WAIT is used to arbitrate collisions between refresh and READ/WRITE operations. WAIT is asserted at the end of a row unless wrapping within the burst length. WAIT is asserted and should be ignored during asynchronous and page mode operations. WAIT is High-Z when CE# is HIGH.
J4, J5, J6	RFU	—	Reserved for future use.
D6	Vcc	Supply	Device power supply: (1.7–1.95V) Power supply for device core operation.
E1	VccQ	Supply	I/O power supply: (1.7–3.6V) Power supply for input/output buffers.
E6	Vss	Supply	Vss must be connected to ground.
D1	VssQ	Supply	VssQ must be connected to ground.

- Notes: 1. The CLK and ADV# inputs can be tied to Vss if the device is always operating in asynchronous or page mode. WAIT will be asserted but should be ignored during asynchronous and page mode operations.







64Mb: 4 Meg x 16 Async/Page/Burst CellularRAM 1.5 Memory General Description

Table 2: Bus Operations – Asynchronous Mode (BCR[15] = 1; Default)

Mode	Power	CLK ¹	ADV#	CE#	OE#	WE#	CRE	LB#/ UB#	WAIT ²	DQ[15:0] ³	Notes
Read	Active	L	L	L	L	H	L	L	Low-Z	Data-out	4
Write	Active	L	L	L	X	L	L	L	Low-Z	Data-in	4
Standby	Standby	L	X	H	X	X	L	X	High-Z	High-Z	5, 6
No operation	Idle	L	X	L	X	X	L	X	Low-Z	X	4, 6
Configuration register write	Active	L	L	L	H	L	H	X	Low-Z	High-Z	
Configuration register read	Active	L	L	L	L	H	H	L	Low-Z	Config. reg. out	
DPD	Deep power-down	L	X	H	X	X	X	X	High-Z	High-Z	7

Table 3: Bus Operations – Burst Mode (BCR[15] = 0)

Mode	Power	CLK ¹	ADV#	CE#	OE#	WE#	CRE	LB#/ UB#	WAIT ²	DQ[15:0] ³	Notes
Async read	Active	L	L	L	L	H	L	L	Low-Z	Data-out	4
Async write	Active	L	L	L	X	L	L	L	Low-Z	Data-in	4
Standby	Standby	L	X	H	X	X	L	X	High-Z	High-Z	5, 6
No operation	Idle	L	X	L	X	X	L	X	Low-Z	X	4, 6
Initial burst read	Active		L	L	X	H	L	L	Low-Z	X	4, 8
Initial burst write	Active		L	L	H	L	L	X	Low-Z	X	4, 8
Burst continue	Active		H	L	X	X	X	L	Low-Z	Data-in or Data-out	4, 8
Burst suspend	Active	X	X	L	H	X	X	X	Low-Z	High-Z	4, 8
Configuration register write	Active		L	L	H	L	H	X	Low-Z	High-Z	8, 9
Configuration register read	Active		L	L	L	H	H	L	Low-Z	Config. reg. out	8, 9
DPD	Deep power-down	L	X	H	X	X	X	X	High-Z	High-Z	7

- Notes:
1. CLK must be LOW during asynchronous read and asynchronous write modes, and to achieve standby power during standby and DPD modes. CLK must be static (HIGH or LOW) during burst suspend.
 2. The WAIT polarity is configured through the bus configuration register (BCR[10]).
 3. When LB# and UB# are in select mode (LOW), DQ[15:0] are affected. When only LB# is in select mode, DQ[7:0] are affected. When only UB# is in the select mode, DQ[15:8] are affected.
 4. The device will consume active power in this mode whenever addresses are changed.
 5. When the device is in standby mode, address inputs and data inputs/outputs are internally isolated from any external influence.
 6. VIN = VccQ or 0V; all device balls must be static (unswitched) to achieve standby current.
 7. DPD is initiated when CE# transitions from LOW to HIGH after writing RCR[4] to 0. DPD is maintained until CE# transitions from HIGH to LOW and is held LOW for ^tDPDX.
 8. Burst mode operation is initialized through the bus configuration register (BCR[15]).
 9. Initial cycle. Following cycles are the same as BURST CONTINUE. CE# must stay LOW for the equivalent of a single-word burst (as indicated by WAIT).



64Mb: 4 Meg x 16 Async/Page/Burst CellularRAM 1.5 Memory Part-Numbering Information

Part-Numbering Information

Micron CellularRAM devices are available in several different configurations and densities. See Figure 3 for part number information.

Figure 3: Part Number Chart

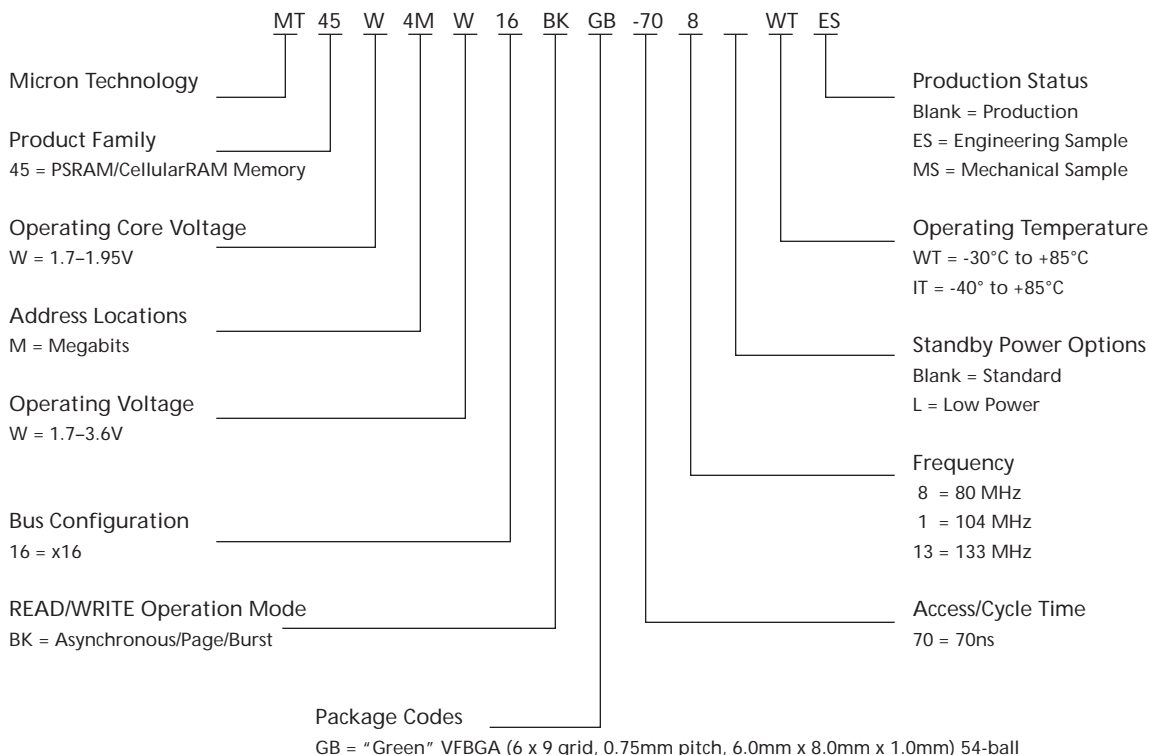

Device Marking

Due to space limitations, FBGA-packaged components have an abbreviated part marking that is different from the part number. Refer to Micron's part marking decoder (www.micron.com/decoder) to translate FBGA codes into current part numbers.



Functional Description

In general, the MT45W4MW16BKGB is a high-density alternative to SRAM and Pseudo SRAM products, popular in low-power, portable applications.

The MT45W4MW16BKGB contains a 67,108,864 bit DRAM core, organized as 4,194,304 addresses by 16 bits. The device implements the same high-speed bus interface found on burst mode Flash products.

The CellularRAM bus interface supports both asynchronous and burst mode transfers. Page mode accesses are also included as a bandwidth-enhancing extension to the asynchronous read protocol.

Power-Up Initialization

CellularRAM products include an on-chip voltage sensor used to launch the power-up initialization process. Initialization will configure the BCR and the RCR with their default settings. See Figure 18 on page 24 and Figure 24 on page 31 for details. VCC and VCCQ must be applied simultaneously. When they reach a stable level at or above 1.7V, the device will require 150 μ s to complete its self-initialization process. During the initialization period, CE# should remain HIGH. When initialization is complete, the device is ready for normal operation.

Figure 4: Power-Up Initialization Timing

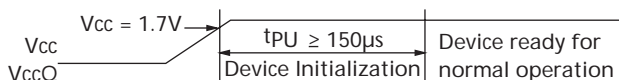

Bus Operating Modes

The MT45W4MW16BKGB incorporates a burst mode interface found on Flash products targeting low-power, wireless applications. This bus interface supports asynchronous, page mode, and burst mode read and write transfers. The specific interface supported is defined by the value loaded into the BCR. Page mode is controlled by the refresh configuration register (RCR[7]).

Asynchronous Mode

CellularRAM products power up in the asynchronous operating mode. This mode uses the industry-standard SRAM control bus (CE#, OE#, WE#, LB#/UB#). READ operations (see Figure 5) are initiated by bringing CE#, OE#, and LB#/UB# LOW while keeping WE# HIGH. Valid data will be driven out of the I/Os after the specified access time has elapsed. WRITE operations (Figure 6) occur when CE#, WE#, and LB#/UB# are driven LOW. During asynchronous WRITE operations, the OE# level is a “Don’t Care,” and WE# will override OE#. The data to be written is latched on the rising edge of CE#, WE#, or LB#/UB# (whichever occurs first). Asynchronous operations (page mode disabled) can either use the ADV# input to latch the address, or ADV# can be driven LOW during the entire READ/WRITE operation.

During asynchronous operation, the CLK input must be held static LOW. WAIT will be driven while the device is enabled and its state should be ignored. WE# LOW time must be limited to t_{CEM} .



64Mb: 4 Meg x 16 Async/Page/Burst CellularRAM 1.5 Memory Bus Operating Modes

Figure 5: READ Operation (ADV# LOW)

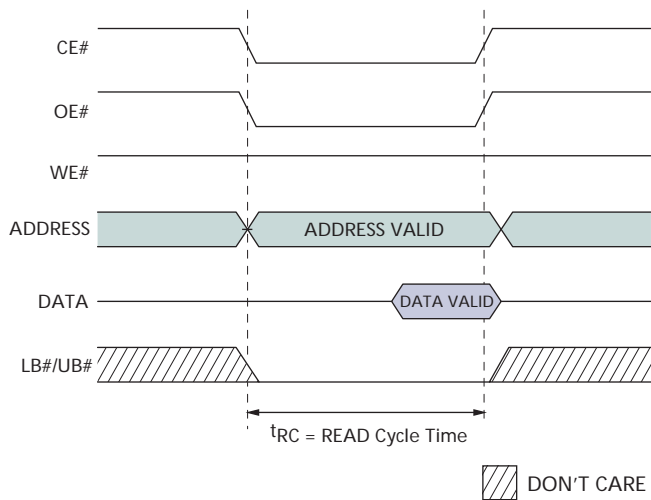

Note: ADV# must remain LOW for page mode operation.

Figure 6: WRITE Operation (ADV# LOW)

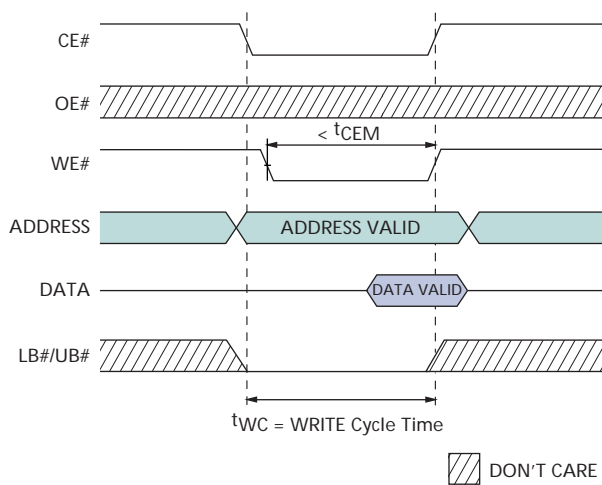



Page Mode READ Operation

Page mode is a performance-enhancing extension to the legacy asynchronous READ operation. In page-mode-capable products, an initial asynchronous read access is performed, then adjacent addresses can be read quickly by simply changing the low-order address. Addresses A[3:0] are used to determine the members of the 16-address CellularRAM page. Any change in addresses A[4] or higher will initiate a new t_{AA} access time. Figure 7 shows the timing for a page mode access. Page mode takes advantage of the fact that adjacent addresses can be read in a shorter period of time than random addresses. WRITE operations do not include comparable page mode functionality.

During asynchronous page mode operation, the CLK input must be held LOW. CE# must be driven HIGH upon completion of a page mode access. CE# must be driven HIGH upon completion of a page mode access. WAIT will be driven while the device is enabled and its state should be ignored. Page mode is enabled by setting RCR[7] to HIGH. ADV# must be driven LOW during all page mode read accesses.

Due to refresh considerations, CE# must not remain LOW longer than t_{CEM} .

Figure 7: Page Mode READ Operation (ADV# LOW)

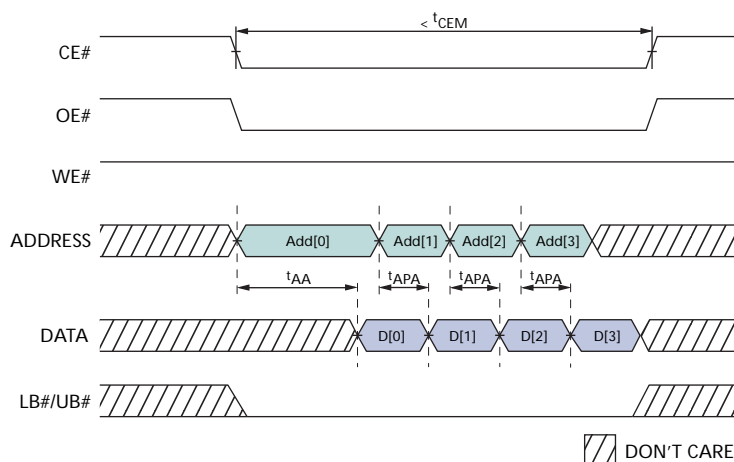

Burst Mode Operation

Burst mode operations enable high-speed synchronous READ and WRITE operations. Burst operations consist of a multi-clock sequence that must be performed in an ordered fashion. After CE# goes LOW, the address to access is latched on the rising edge of the next clock that ADV# is LOW. During this first clock rising edge, WE# indicates whether the operation is going to be a READ (WE# = HIGH, Figure 8 on page 13) or WRITE (WE# = LOW, Figure 9 on page 14).

The size of a burst can be specified in the BCR either as a fixed length or continuous. Fixed-length bursts consist of four, eight, sixteen, or thirty-two words. Continuous bursts have the ability to start at a specified address and burst to the end of the 128-word row.

The latency count stored in the BCR defines the number of clock cycles that elapse before the initial data value is transferred between the processor and CellularRAM device. The initial latency for READ operations can be configured as fixed or variable (WRITE operations always use fixed latency). Variable latency allows the CellularRAM to be configured for minimum latency at high clock frequencies, but the controller must monitor WAIT to detect any conflict with refresh cycles.



64Mb: 4 Meg x 16 Async/Page/Burst CellularRAM 1.5 Memory Bus Operating Modes

Fixed latency outputs the first data word after the worst-case access delay, including allowance for refresh collisions. The initial latency time and clock speed determine the latency count setting. Fixed latency is used when the controller cannot monitor WAIT. Fixed latency also provides improved performance at lower clock frequencies.

The WAIT output asserts when a burst is initiated, and de-asserts to indicate when data is to be transferred into (or out of) the memory. WAIT will again be asserted at the boundary of the 128-word row, unless wrapping within the burst length.

To access other devices on the same bus without the timing penalty of the initial latency for a new burst, burst mode can be suspended. Bursts are suspended by stopping CLK. CLK can be stopped HIGH or LOW. If another device will use the data bus while the burst is suspended, OE# should be taken HIGH to disable the CellularRAM device outputs; otherwise, OE# can remain LOW. Note that the WAIT output will continue to be active, and as a result no other devices should directly share the WAIT connection to the controller. To continue the burst sequence, OE# is taken LOW, then CLK is restarted after valid data is available on the bus.

The CE# LOW time is limited by refresh considerations. CE# must not stay LOW longer than t_{CEM} . If a burst suspension will cause CE# to remain LOW for longer than t_{CEM} , CE# should be taken HIGH and the burst restarted with a new CE# LOW/ADV# LOW cycle.

Figure 8: Burst Mode READ (4-word Burst)

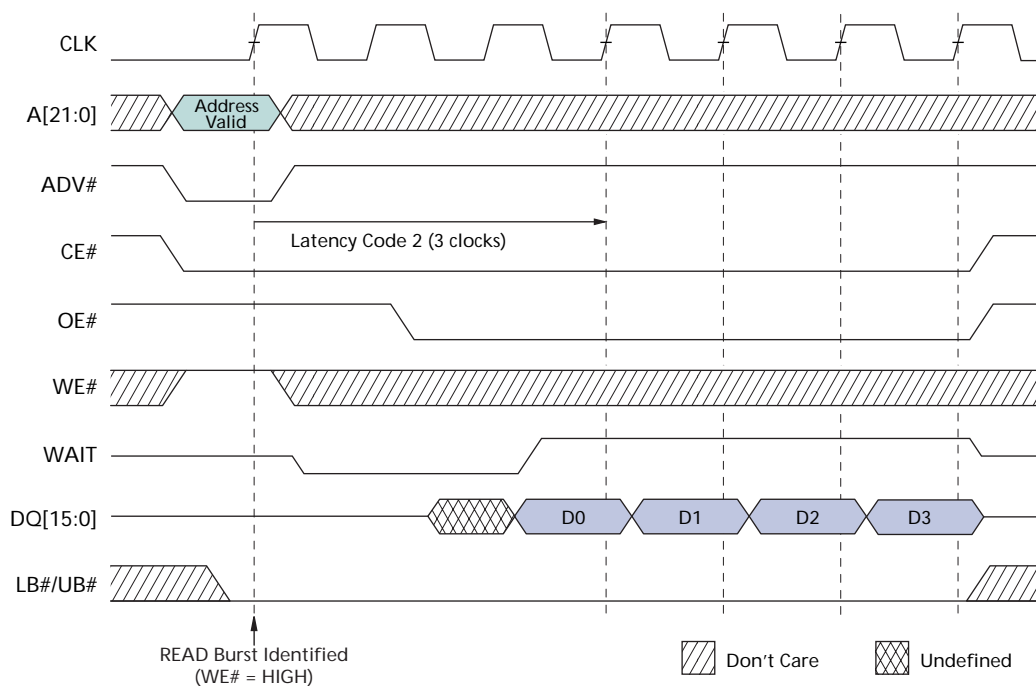

- Notes: 1. Non-default BCR settings for burst mode READ (4-word burst): Fixed or variable latency; latency code two (three clocks); WAIT active LOW; WAIT asserted during delay. Figure 8 is representative of variable latency with no refresh collision or fixed-latency access.



64Mb: 4 Meg x 16 Async/Page/Burst CellularRAM 1.5 Memory Bus Operating Modes

Figure 9: Burst Mode WRITE (4-word Burst)

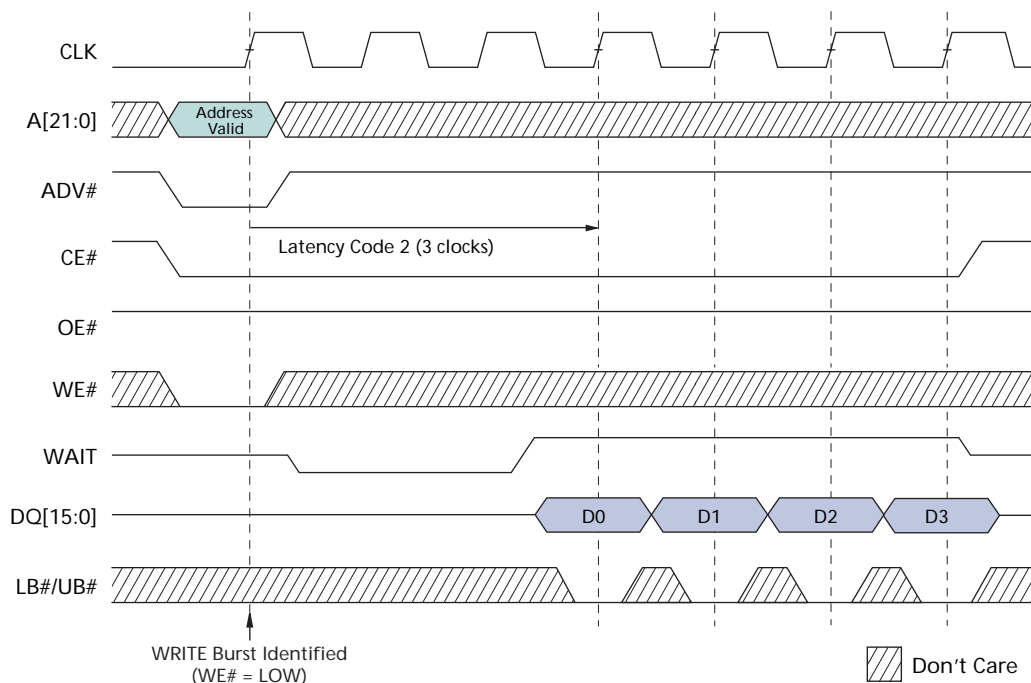

- Notes: 1. Non-default BCR settings for burst mode WRITE (4-word burst): Fixed or variable latency; latency code two (three clocks); WAIT active LOW; WAIT asserted during delay.

Mixed-Mode Operation

The device supports a combination of synchronous READ and asynchronous READ and WRITE operations when the BCR is configured for synchronous operation. The asynchronous READ and WRITE operations require that the clock (CLK) remain LOW during the entire sequence. The ADV# signal can be used to latch the target address, or it can remain LOW during the entire WRITE operation. CE# can remain LOW when transitioning between mixed-mode operations with fixed latency enabled; however, the CE# LOW time must not exceed t_{CEM} . Mixed-mode operation facilitates a seamless interface to legacy burst mode Flash memory controllers. See Figure 50 on page 63 for the “Asynchronous WRITE Followed by Burst READ” timing diagram.

WAIT Operation

The WAIT output on a CellularRAM device is typically connected to a shared, system-level WAIT signal (see Figure 10). The shared WAIT signal is used by the processor to coordinate transactions with multiple memories on the synchronous bus.

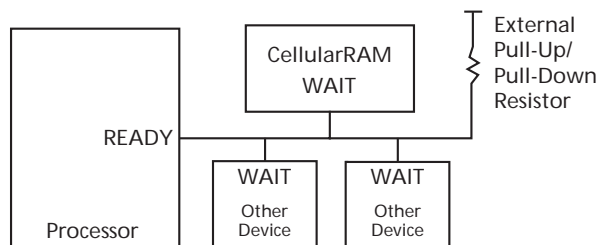
Figure 10: Wired-OR WAIT Configuration

Once a READ or WRITE operation has been initiated, WAIT goes active to indicate that the CellularRAM device requires additional time before data can be transferred. For READ operations, WAIT will remain active until valid data is output from the device. For WRITE operations, WAIT will indicate to the memory controller when data will be accepted into the CellularRAM device. When WAIT transitions to an inactive state, the data burst will progress on successive clock edges.

During a burst cycle, CE# must remain asserted until the first data is valid. Bringing CE# HIGH during this initial latency may cause data corruption.

When using variable initial access latency (BCR[14] = 0), the WAIT output performs an arbitration role for READ operations launched while an on-chip refresh is in progress. If a collision occurs, WAIT is asserted for additional clock cycles until the refresh has completed. (See Figure 11 on page 16.) When the refresh operation has completed, the READ operation will continue normally.

WAIT will be asserted but should be ignored during asynchronous READ, WRITE, and PROGRAM operations.

By using fixed initial latency (BCR[14] = 1), this CellularRAM device can be used in burst mode without monitoring the WAIT signal. However, WAIT can still be used to determine when valid data is available at the start of the burst and at the end of a row. If WAIT is not monitored, the controller must stop burst accesses at row boundaries on its own.

LB#/UB# Operation

The LB# enable and UB# enable signals support byte-wide data WRITES. During WRITE operations, any disabled bytes will not be transferred to the RAM array and the internal value will remain unchanged. During an asynchronous WRITE cycle, the data to be written is latched on the rising edge of CE#, WE#, LB#, or UB#, whichever occurs first. LB#/UB# must be LOW during READ cycles.

When both LB# and UB# are disabled (HIGH) during an operation, the device will disable the data bus from receiving or transmitting data. Although the device will seem to be deselected, it remains in an active mode as long as CE# remains LOW.



64Mb: 4 Meg x 16 Async/Page/Burst CellularRAM 1.5 Memory Bus Operating Modes

Figure 11: Refresh Collision During Variable-Latency READ Operation

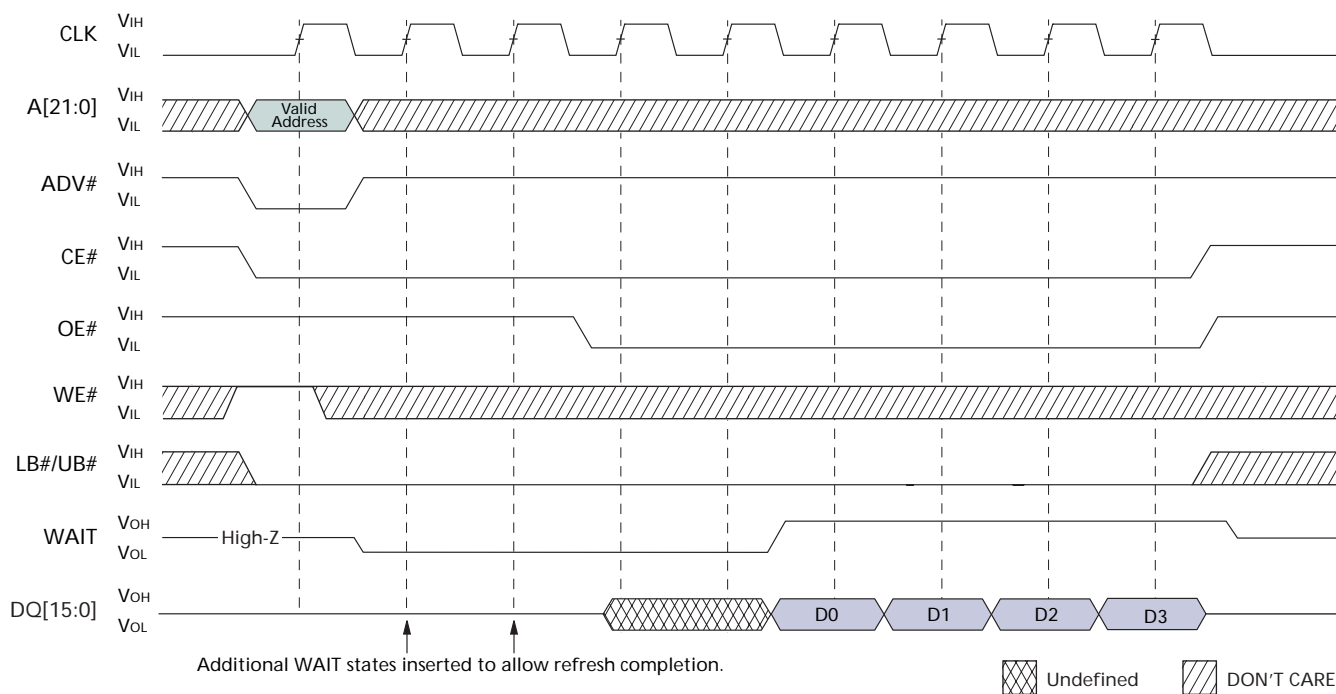

Notes: 1. Non-default BCR settings for refresh collision during variable-latency READ operation: latency code two (three clocks); WAIT active LOW; WAIT asserted during delay.



Low-Power Operation

Standby Mode Operation

During standby, the device current consumption is reduced to the level necessary to perform the DRAM refresh operation. Standby operation occurs when CE# is HIGH.

The device will enter a reduced power state upon completion of a READ or WRITE operation, or when the address and control inputs remain static for an extended period of time. This mode will continue until a change occurs to the address or control inputs.

Temperature-Compensated Refresh (TCR)

This CellularRAM device includes an on-chip temperature sensor that continuously adjusts the refresh rate according to the operating temperature.

Partial-Array Refresh (PAR)

Partial-array refresh (PAR) restricts refresh operation to a portion of the total memory array. This feature enables the device to reduce standby current by refreshing only that part of the memory array required by the host system. The refresh options are full array, one-half array, one-quarter array, one-eighth array, or none of the array. The mapping of these partitions can start at either the beginning or the end of the address map. (See Table 8 on page 32.) READ and WRITE operations to address ranges receiving refresh will not be affected. Data stored in addresses not receiving refresh will become corrupted. When re-enabling additional portions of the array, the new portions are available immediately upon writing to the RCR.

Deep Power-Down Operation (DPD)

Deep power-down (DPD) operation disables all refresh-related activity. This mode is used if the system does not require the storage provided by the CellularRAM device. Any stored data will become corrupted when DPD is enabled. When refresh activity has been re-enabled by rewriting, the CellularRAM device will require 150 μ s to perform an initialization procedure before normal operations can resume. During this 150 μ s period, the current consumption will be higher than the specified standby levels, but considerably lower than the active current specification.

DPD can be enabled by writing to the RCR using CRE or the software access sequence; DPD starts when CE# goes HIGH. DPD is disabled the next time CE# goes LOW and stays LOW for at least 10 μ s.

Registers

Two user-accessible configuration registers define the device operation. The bus configuration register (BCR) defines how the CellularRAM interacts with the system memory bus and is nearly identical to its counterpart on burst mode Flash devices. The refresh configuration register (RCR) is used to control how refresh is performed on the DRAM array. These registers are automatically loaded with default settings during power-up, and can be updated any time the devices are operating in a standby state.

The DIDR provides information on the device manufacturer, CellularRAM generation, and the specific device configuration. The DIDR is read-only.



Access Using CRE

The registers can be accessed using either a synchronous or an asynchronous operation when the control register enable (CRE) input is HIGH (see Figures 12 through 15 on pages 18 through 21). When CRE is LOW, a READ or WRITE operation will access the memory array. The configuration register values are written via addresses A[21:0]. In an asynchronous WRITE, the values are latched into the configuration register on the rising edge of ADV#, CE#, or WE#, whichever occurs first; LB# and UB# are “Don’t Care.” The BCR is accessed when A[19:18] are 10b; the RCR is accessed when A[19:18] are 00b. The DIDR is read when A[19:18] are 01b. For reads, address inputs other than A[19:18] are “Don’t Care,” and register bits 15:0 are output on DQ[15:0]. Micron strongly recommends reading the memory array immediately after performing a configuration register READ and WRITE operation.

Figure 12: Configuration Register WRITE, Asynchronous Mode Followed by READ ARRAY

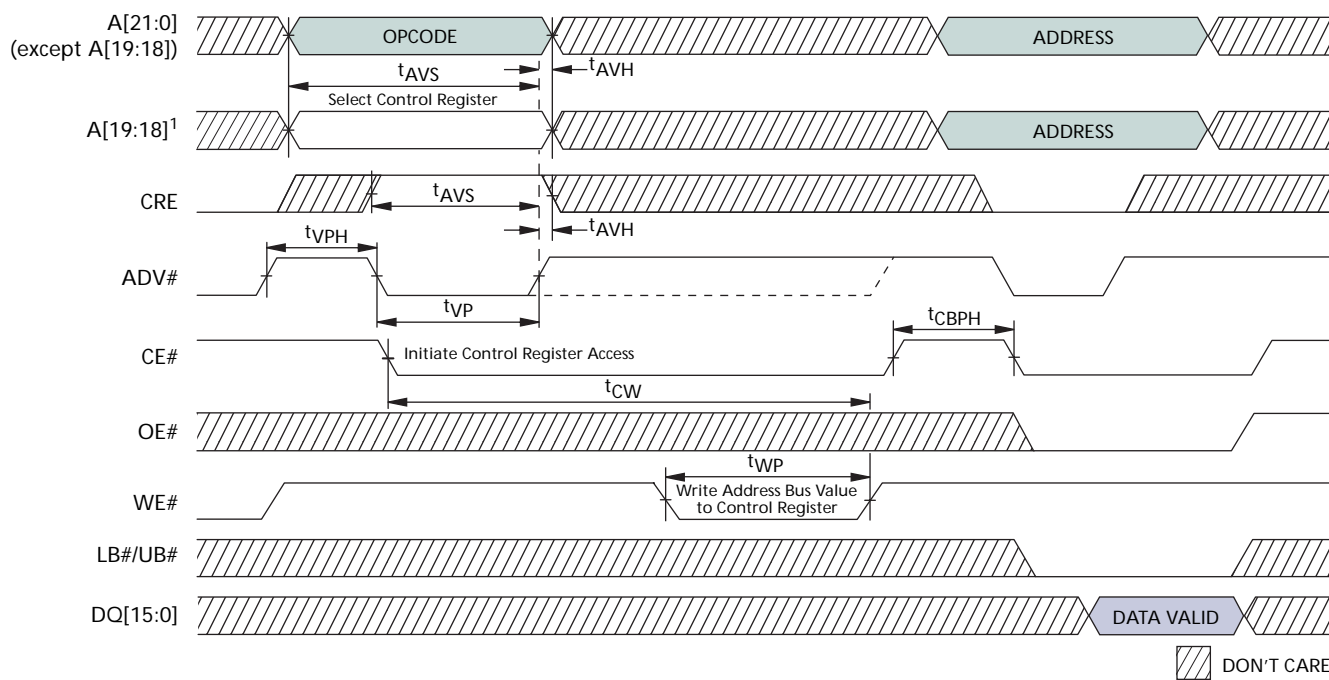

Notes: 1. A[19:18] = 00b to load RCR, and 10b to load BCR.



64Mb: 4 Meg x 16 Async/Page/Burst CellularRAM 1.5 Memory Registers

Figure 13: Configuration Register WRITE, Synchronous Mode Followed by READ ARRAY Operation

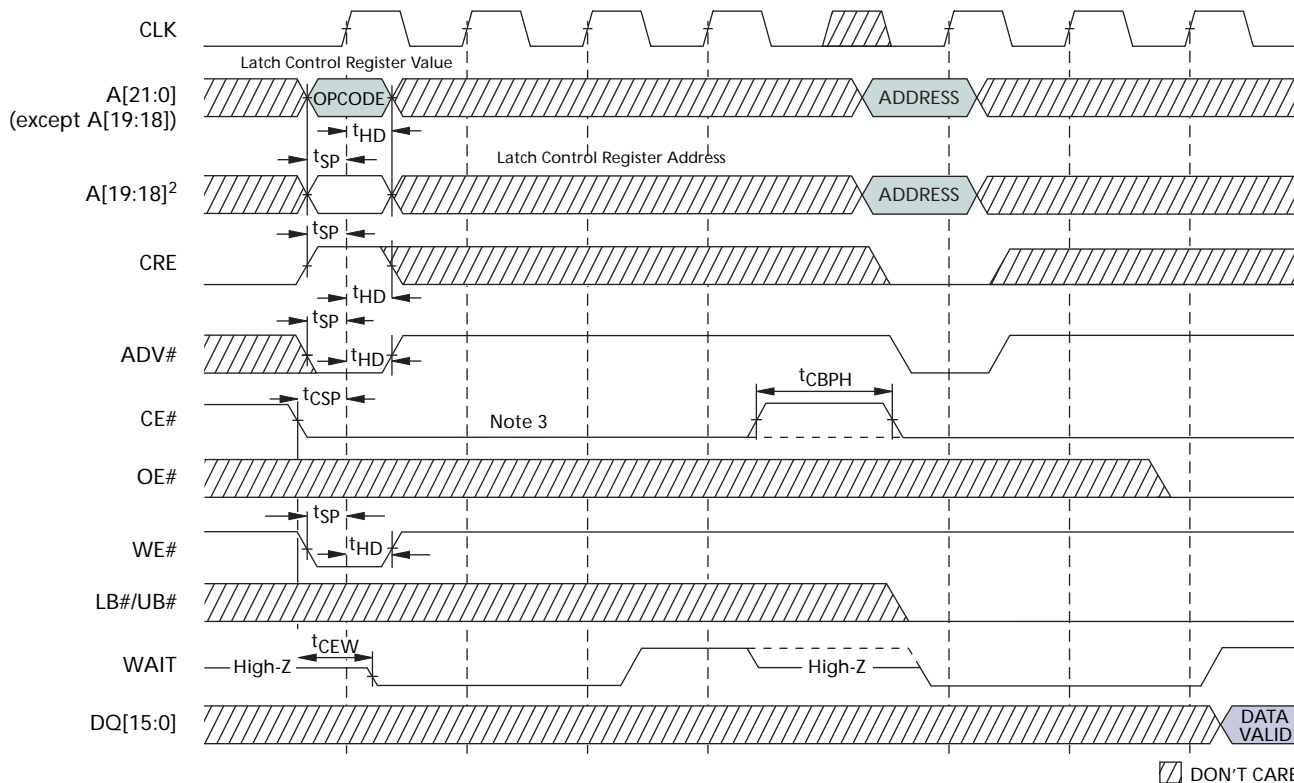

- Notes:
1. Non-default BCR settings for synchronous mode configuration register WRITE followed by READ ARRAY operation: latency code two (three clocks); WAIT active LOW; WAIT asserted during delay.
 2. A[19:18] = 00b to load RCR, and 10b to load BCR.
 3. CE# must remain LOW to complete a burst-of-one WRITE. WAIT must be monitored—additional WAIT cycles caused by refresh collisions require a corresponding number of additional CE# LOW cycles.



64Mb: 4 Meg x 16 Async/Page/Burst CellularRAM 1.5 Memory Registers

Figure 14: Register READ, Asynchronous Mode Followed by READ ARRAY Operation

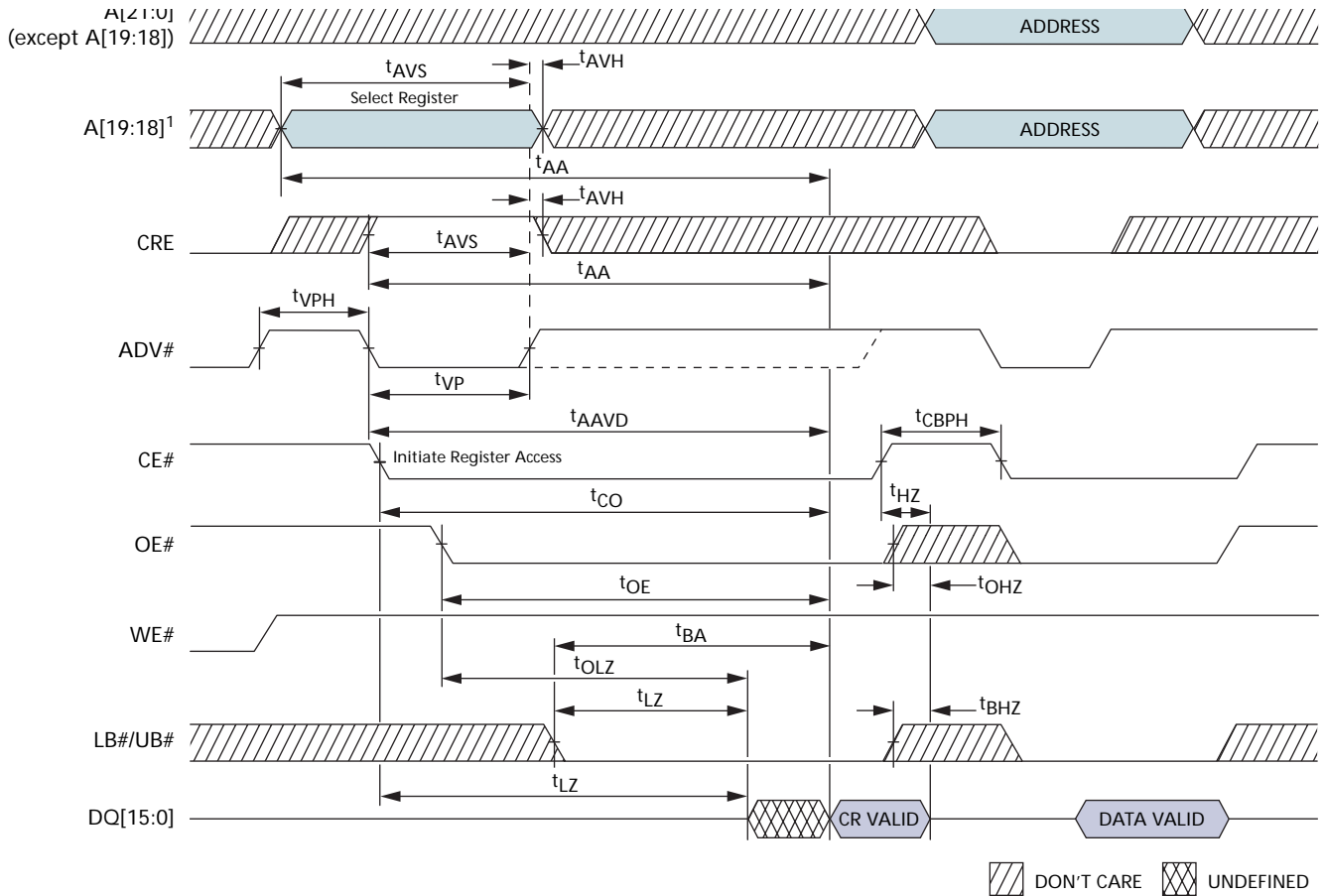

Notes: 1. A[19:18] = 00b to read RCR, 10b to read BCR, and 01b to read DIDR.



64Mb: 4 Meg x 16 Async/Page/Burst CellularRAM 1.5 Memory Registers

Figure 15: Register READ, Synchronous Mode Followed by READ ARRAY Operation

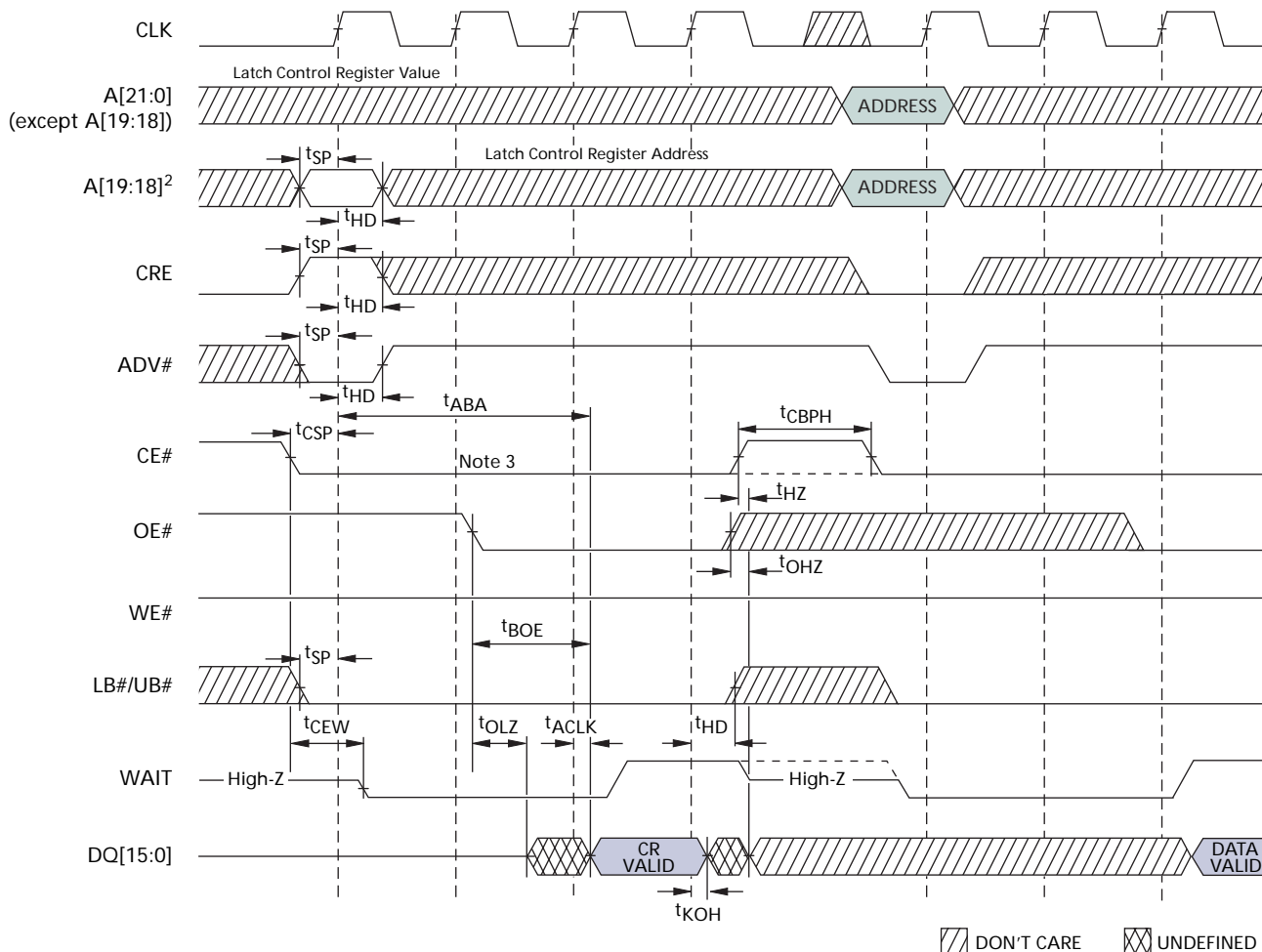

- Notes:
1. Non-default BCR settings for synchronous mode register READ followed by READ ARRAY operation: latency code two (three clocks); WAIT active LOW; WAIT asserted during delay.
 2. A[19:18] = 00b to read RCR, 10b to read BCR, and 01b to read DIDR.
 3. CE# must remain LOW to complete a burst-of-one READ. WAIT must be monitored—additional WAIT cycles caused by refresh collisions require a corresponding number of additional CE# LOW cycles.



Software Access

Software access of the registers uses a sequence of asynchronous READ and asynchronous WRITE operations. The contents of the configuration registers can be modified and all registers can be read using the software sequence.

The configuration registers are loaded using a four-step sequence consisting of two asynchronous READ operations followed by two asynchronous WRITE operations (see Figure 16). The read sequence is virtually identical except that an asynchronous READ is performed during the fourth operation (see Figure 17). The address used during all READ and WRITE operations is the highest address of the CellularRAM device being accessed (3FFFFFFh for 64Mb); the contents of this address are not changed by using this sequence.

The data value presented during the third operation (WRITE) in the sequence defines whether the BCR, RCR, or the DIDR is to be accessed. If the data is 0000h, the sequence will access the RCR; if the data is 0001h, the sequence will access the BCR; if the data is 0002h, the sequence will access the DIDR. During the fourth operation, DQ[15:0] transfer data in to or out of bits 15-0 of the registers.

The use of the software sequence does not affect the ability to perform the standard (CRE-controlled) method of loading the configuration registers. However, the software nature of this access mechanism eliminates the need for CRE. If the software mechanism is used, CRE can simply be tied to Vss. The port line often used for CRE control purposes is no longer required.

Figure 16: Load Configuration Register

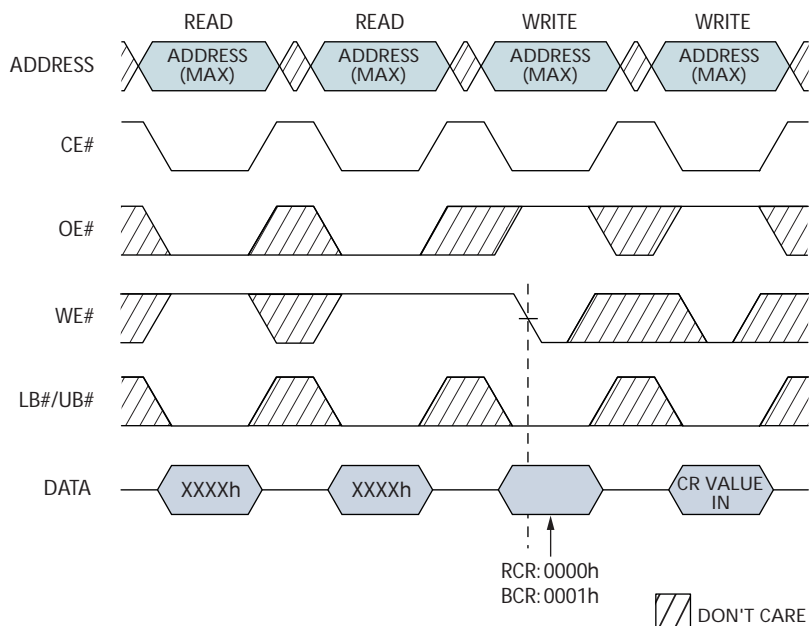



64Mb: 4 Meg x 16 Async/Page/Burst CellularRAM 1.5 Memory Registers

Figure 17: Read Configuration Register

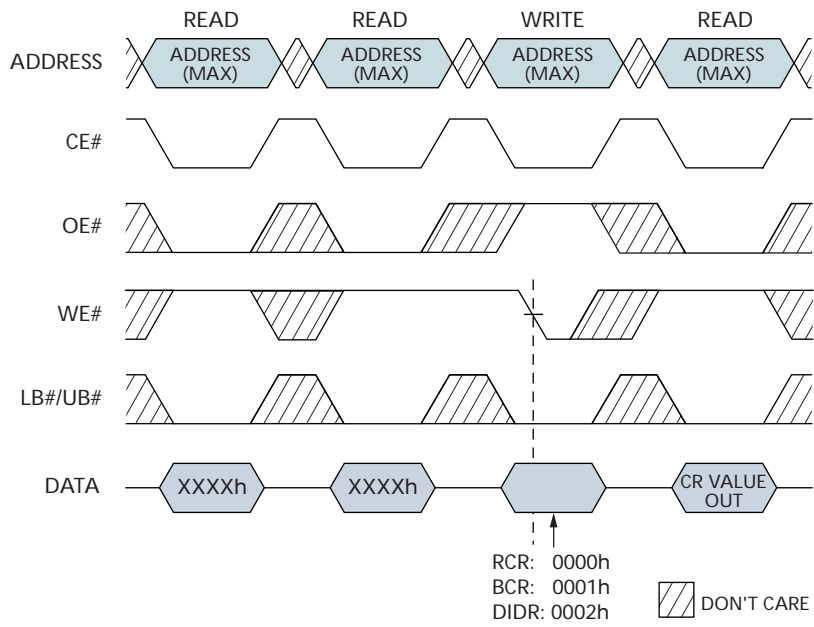



64Mb: 4 Meg x 16 Async/Page/Burst CellularRAM 1.5 Memory Registers

Bus Configuration Register (BCR)

The BCR defines how the CellularRAM device interacts with the system memory bus. Page mode operation is enabled by a bit contained in the RCR. Figure 18 describes the control bits in the BCR. At power-up, the BCR is set to 9D1Fh.

The BCR is accessed with CRE HIGH and A[19:18] = 10b, or through the register access software sequence with DQ = 0001h on the third cycle.

Figure 18: Bus Configuration Register Definition

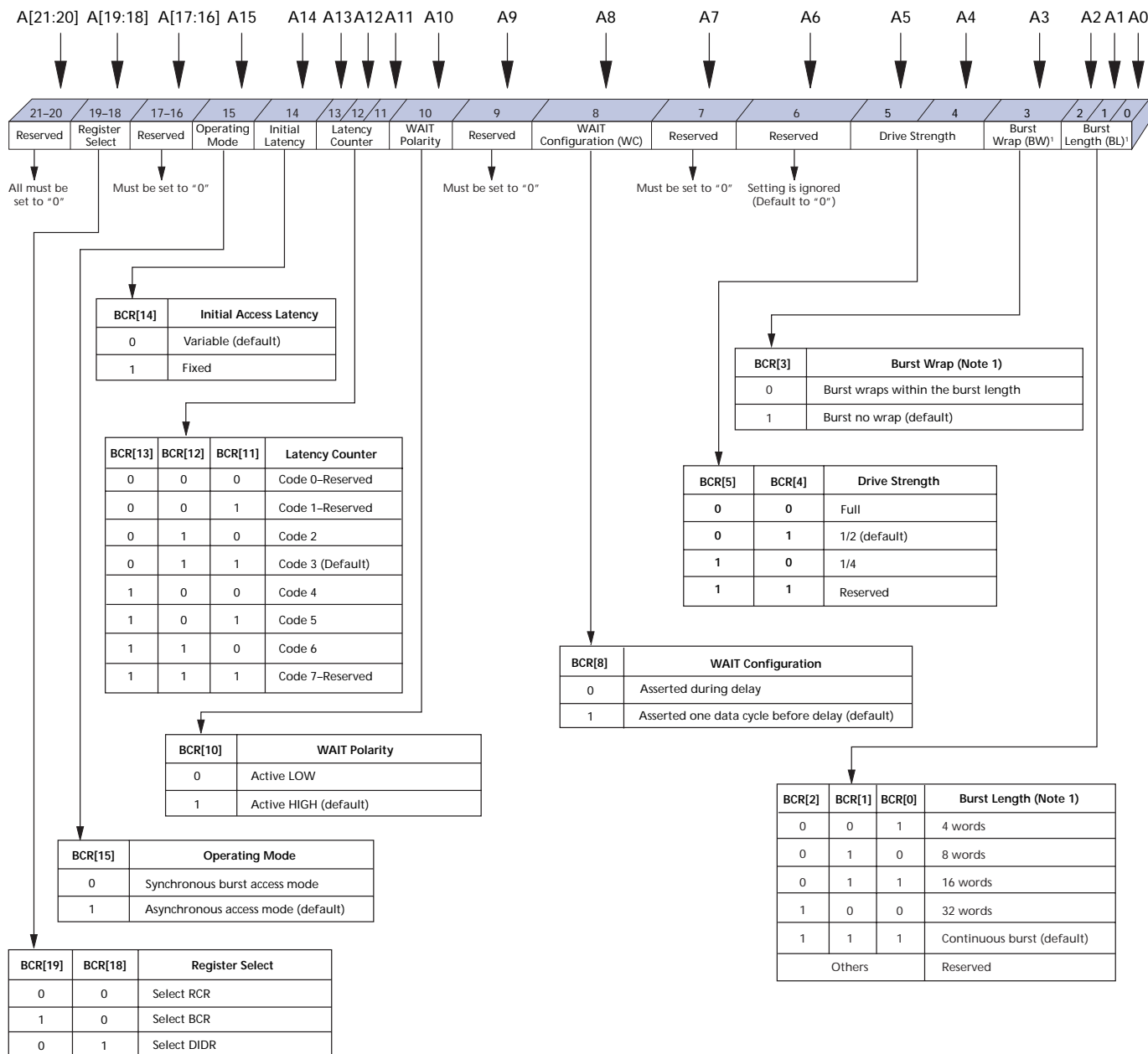

Notes: 1. Burst wrap and length apply to both READ and WRITE operations.

**Burst Length (BCR[2:0]) Default = Continuous Burst**

Burst lengths define the number of words the device outputs during burst READ and WRITE operations. The device supports a burst length of 4, 8, 16, or 32 words. The device can also be set in continuous burst mode where data is accessed sequentially up to the end of the row.

Burst Wrap (BCR[3]) Default = No Wrap

The burst-wrap option determines if a 4-, 8-, 16-, or 32-word READ or WRITE burst wraps within the burst length, or steps through sequential addresses. If the wrap option is not enabled, the device accesses data from sequential addresses up to the end of the row.



Table 4: Sequence and Burst Length

Burst Wrap		Starting Address	4-Word Burst Length	8-Word Burst Length	16-Word Burst Length	32-Word Burst Length	Continuous Burst
BCR[3]	WRAP	(Decimal)	Linear	Linear	Linear	Linear	Linear
0	Yes	0	0-1-2-3	0-1-2-3-4-5-6-7	0-1-2-3-4-5-6-7-8-9-10-11-12-13-14-15	0-1-2-...-29-30-31	0-1-2-3-4-5-6-...
		1	1-2-3-0	1-2-3-4-5-6-7-0	1-2-3-4-5-6-7-8-9-10-11-12-13-14-15-0	1-2-3-...-30-31-0	1-2-3-4-5-6-7-...
		2	2-3-0-1	2-3-4-5-6-7-0-1	2-3-4-5-6-7-8-9-10-11-12-13-14-15-0-1	2-3-4-...-31-0-1	2-3-4-5-6-7-8-...
		3	3-0-1-2	3-4-5-6-7-0-1-2	3-4-5-6-7-8-9-10-11-12-13-14-15-0-1-2	3-4-5-...-0-1-2	3-4-5-6-7-8-9-...
		4		4-5-6-7-0-1-2-3	4-5-6-7-8-9-10-11-12-13-14-15-0-1-2-3	4-5-6-...-1-2-3	4-5-6-7-8-9-10-...
		5		5-6-7-0-1-2-3-4	5-6-7-8-9-10-11-12-13-14-15-0-1-2-3-4	5-6-7-...-2-3-4	5-6-7-8-9-10-11-...
		6		6-7-0-1-2-3-4-5	6-7-8-9-10-11-12-13-14-15-0-1-2-3-4-5	6-7-8-...-3-4-5	6-7-8-9-10-11-12-
		7		7-0-1-2-3-4-5-6	7-8-9-10-11-12-13-14-15-0-1-2-3-4-5-6	7-8-9-...-4-5-6	7-8-9-10-11-12-13-...
	
		14			14-15-0-1-2-3-4-5-6-7-8-9-10-11-12-13	14-15-16-...-11-12-13	14-15-16-17-18-19-20-...
		15			15-0-1-2-3-4-5-6-7-8-9-10-11-12-13-14	15-16-17-...-12-13-14	15-16-17-18-19-20-21-...
	
		30				30-31-0-...-27-28-29	30-31-32-33-34-...
		31				31-0-1-...-28-29-30	31-32-33-34-35-...
1	No	0	0-1-2-3	0-1-2-3-4-5-6-7	0-1-2-3-4-5-6-7-8-9-10-11-12-13-14-15	0-1-2-...-29-30-31	0-1-2-3-4-5-6-...
		1	1-2-3-4	1-2-3-4-5-6-7-8	1-2-3-4-5-6-7-8-9-10-11-12-13-14-15-16	1-2-3-...-30-31-32	1-2-3-4-5-6-7-...
		2	2-3-4-5	2-3-4-5-6-7-8-9	2-3-4-5-6-7-8-9-10-11-12-13-14-15-16-17	2-3-4-...-31-32-33	2-3-4-5-6-7-8-...
		3	3-4-5-6	3-4-5-6-7-8-9-10	3-4-5-6-7-8-9-10-11-12-13-14-15-16-17-18	3-4-5-...-32-33-34	3-4-5-6-7-8-9-...
		4		4-5-6-7-8-9-10-11	4-5-6-7-8-9-10-11-12-13-14-15-16-17-18-19	4-5-6-...-33-34-35	4-5-6-7-8-9-10-...
		5		5-6-7-8-9-10-11-12	5-6-7-8-9-10-11-12-13-...-15-16-17-18-19-20	5-6-7-...-34-35-36	5-6-7-8-9-10-11-...
		6		6-7-8-9-10-11-12-13	6-7-8-9-10-11-12-13-14-...-16-17-18-19-20-21	6-7-8-...-35-36-37	6-7-8-9-10-11-12-...
		7		7-8-9-10-11-12-13-14	7-8-9-10-11-12-13-14-...-17-18-19-20-21-22	7-8-9-...-36-37-38	7-8-9-10-11-12-13-...
	
		14			14-15-16-17-18-19-...-23-24-25-26-27-28-29	14-15-16-...-43-44-45	14-15-16-17-18-19-20-...
		15			15-16-17-18-19-20-...-24-25-26-27-28-29-30	15-16-17-...-44-45-46	15-16-17-18-19-20-21-...
	
		30				30-31-32-...-59-60-61	30-31-32-33-34-35-36-...
		31				31-32-33-...-60-61-62	31-32-33-34-35-36-37-...

Drive Strength (BCR[5:4]) Default = Outputs Use Half-Drive Strength

The output driver strength can be altered to full, one-half, or one-quarter strength to adjust for different data bus loading scenarios. The reduced-strength options are intended for stacked chip (Flash + CellularRAM) environments when there is a dedicated memory bus. The reduced-drive-strength option minimizes the noise generated on the data bus during READ operations. Full output drive strength should be selected when using a discrete CellularRAM device in a more heavily loaded data bus environment. Outputs are configured at half-drive strength during testing. See Table 5 for additional information.

Table 5: Drive Strength

BCR[5]	BCR[4]	Drive Strength	Impedance Typ (Ω)	Use Recommendation
0	0	Full	25–30	CL = 30pF to 50pF
0	1	1/2 (default)	50	CL = 15pF to 30pF, 104 MHz at light load
1	0	1/4	100	CL = 15pF or lower
1	1	Reserved		

WAIT Configuration (BCR[8]) Default = WAIT Transitions One Clock Before Data Valid/Invalid

The WAIT configuration bit is used to determine when WAIT transitions between the asserted and the de-asserted state with respect to valid data presented on the data bus. The memory controller will use the WAIT signal to coordinate data transfer during synchronous READ and WRITE operations. When BCR[8] = 0, data will be valid or invalid on the clock edge immediately after WAIT transitions to the de-asserted or asserted state, respectively (see Figures 19 and 21). When A8 = 1, the WAIT signal transitions one clock period prior to the data bus going valid or invalid (see Figures 20 and 21).

WAIT Polarity (BCR[10]) Default = WAIT Active HIGH

The WAIT polarity bit indicates whether an asserted WAIT output should be HIGH or LOW. This bit will determine whether the WAIT signal requires a pull-up or pull-down resistor to maintain the de-asserted state.

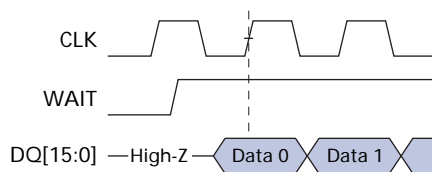
Figure 19: WAIT Configuration (BCR[8] = 0)

- Notes: 1. Data valid/invalid immediately after WAIT transitions (BCR[8] = 0) (see Figure 21).

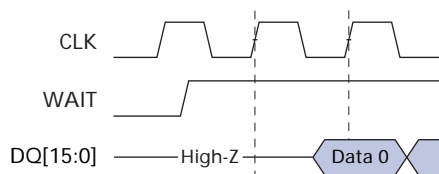
Figure 20: WAIT Configuration (BCR[8] = 1)

Notes: 1. Valid/invalid data delayed for one clock after WAIT transitions (BCR[8] = 1) (see Figure 21).

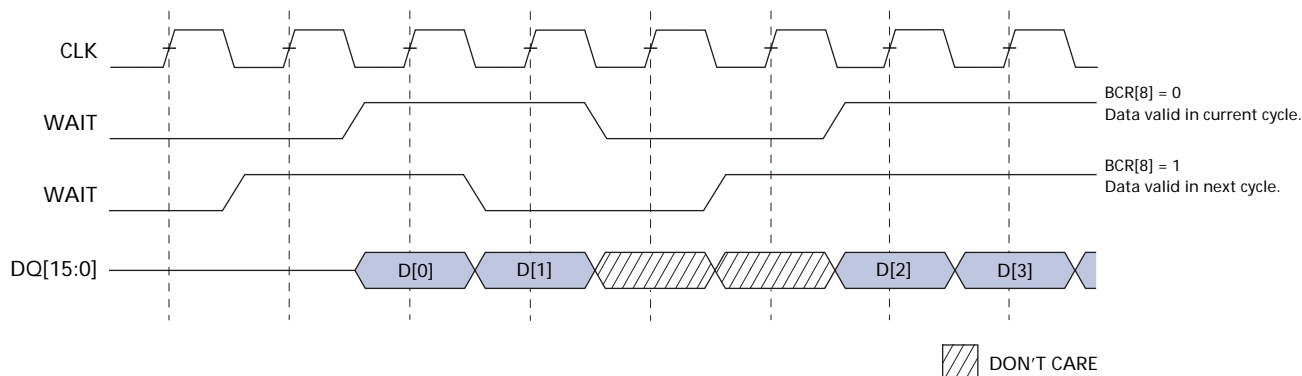
Figure 21: WAIT Configuration During Burst Operation

Notes: 1. Non-default BCR setting: WAIT active LOW.

Latency Counter (BCR[13:11]) Default = Three Clock Latency

The latency counter bits determine how many clocks occur between the beginning of a READ or WRITE operation and the first data value transferred. For allowable latency codes, see Tables 6 and 7 on pages 29 and 30, respectively, and Figures 22 and 23 on pages 29 and 30, respectively.

Initial Access Latency (BCR[14]) Default = Variable

Variable initial access latency outputs data after the number of clocks set by the latency counter. However, WAIT must be monitored to detect delays caused by collisions with refresh operations.

Fixed initial access latency outputs the first data at a consistent time that allows for worst-case refresh collisions. The latency counter must be configured to match the initial latency and the clock frequency. It is not necessary to monitor WAIT with fixed initial latency. The burst begins after the number of clock cycles configured by the latency counter (see Table 7 on page 30 and Figure 23 on page 30).

Operating Mode (BCR[15]) Default = Asynchronous Operation

The operating mode bit selects either synchronous burst operation or the default asynchronous mode of operation.



64Mb: 4 Meg x 16 Async/Page/Burst CellularRAM 1.5 Memory Registers

Table 6: Variable Latency Configuration Codes (BCR [14] = 0)

BCR[13:11]	Latency Configuration Code	Latency ¹		Maximum Input CLK Frequency (MHz)		
		Normal	Refresh Collision	-7013	-701	-708
010	2 (3 clocks)	2	4	66 (15.0ns)	66 (15.0ns)	52 (19.2ns)
011	3 (4 clocks) – default	3	6	104 (9.62ns)	104 (9.62ns)	80 (12.5ns)
100	4 (5 clocks)	4	8	133 (7.5ns)		
Others	Reserved	–	–	–	–	–

Notes: 1. Latency is the number of clock cycles from the initialization of a burst operation until data appears. Data is transferred on the next clock cycle. Read latency can range from the normal latency to the value shown for refresh collision. WRITE latency is fixed at the value shown for normal latency.

Figure 22: Latency Counter (Variable Initial Latency, No Refresh Collision)

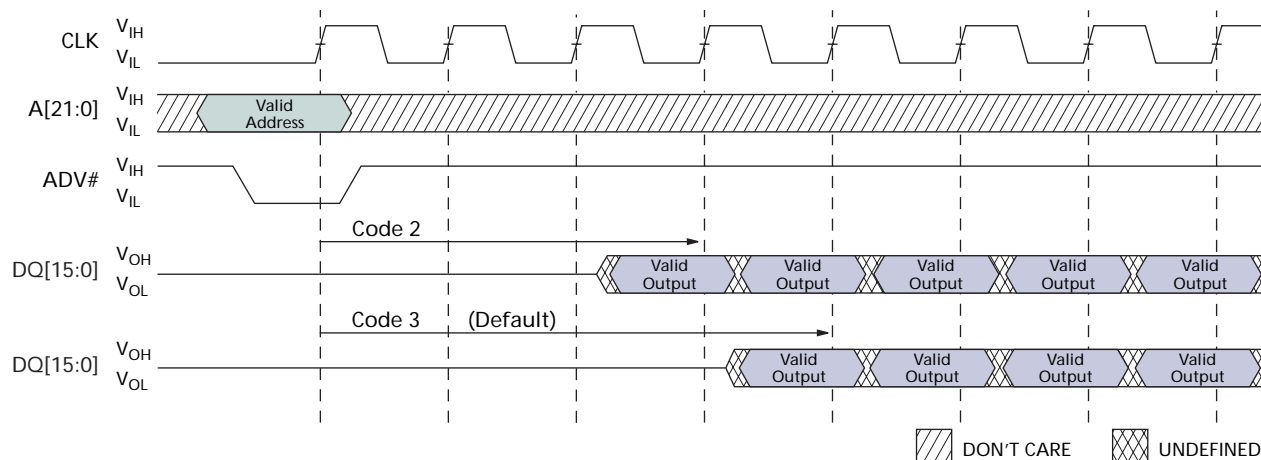



64Mb: 4 Meg x 16 Async/Page/Burst CellularRAM 1.5 Memory Registers

Table 7: Fixed Latency Configuration Codes (BCR[14] = 1)

BCR[13:11]	Latency Configuration Code	Latency Count (N)	Maximum Input CLK Frequency (MHz)		
			-7013	-701	-708
010	2 (3 clocks)	2	33 (30ns)	33 (30ns)	33 (30ns)
011	3 (4 clocks) – default	3	52 (19.2ns)	52 (19.2ns)	52 (19.2ns)
100	4 (5 clocks)	4	66 (15ns)	66 (15ns)	66 (15ns)
101	5 (6 clocks)	5	75 (13.3ns)	75 (13.3ns)	75 (13.3ns)
110	6 (7 clocks)	6	104 (9.62ns)	104 (9.62ns)	80 (12.5ns)
000	8 (9 clocks)	8	133 (7.5ns)		
Others	Reserved	–	–	–	–

Figure 23: Latency Counter (Fixed Latency)

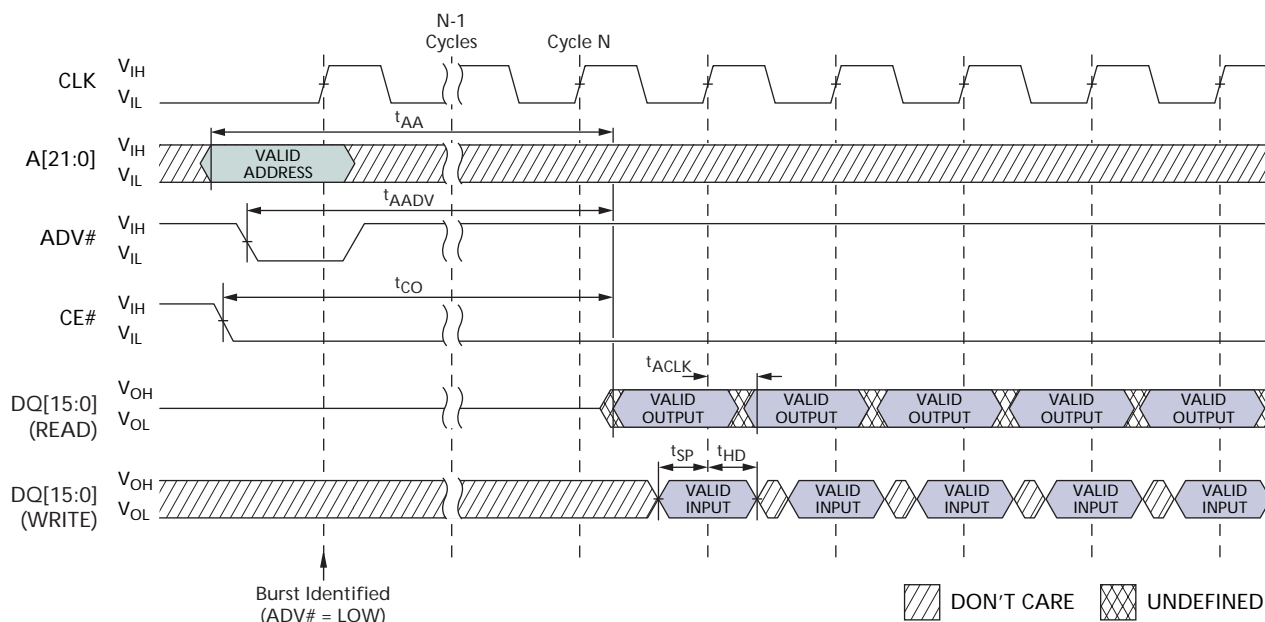



Refresh Configuration Register

The refresh configuration register (RCR) defines how the CellularRAM device performs transparent self refresh. Altering the refresh parameters can dramatically reduce current consumption during standby mode. Page mode control is also embedded into the RCR. Figure 24 describes the control bits used in the RCR. At power-up, the RCR is set to 0010h.

The RCR is accessed with CRE HIGH and A[19:18] = 00b; or through the register access software sequence with DQ = 0000h on the third cycle (see “Registers” on page 17).

Partial-Array Refresh (RCR[2:0]) Default = Full Array Refresh

The PAR bits restrict refresh operation to a portion of the total memory array. This feature allows the device to reduce standby current by refreshing only that part of the memory array required by the host system. The refresh options are full array, one-half array, one-quarter array, one-eighth array, or none of the array. The mapping of these partitions can start at either the beginning or the end of the address map (see Table 8 on page 32).

Figure 24: Refresh Configuration Register Mapping

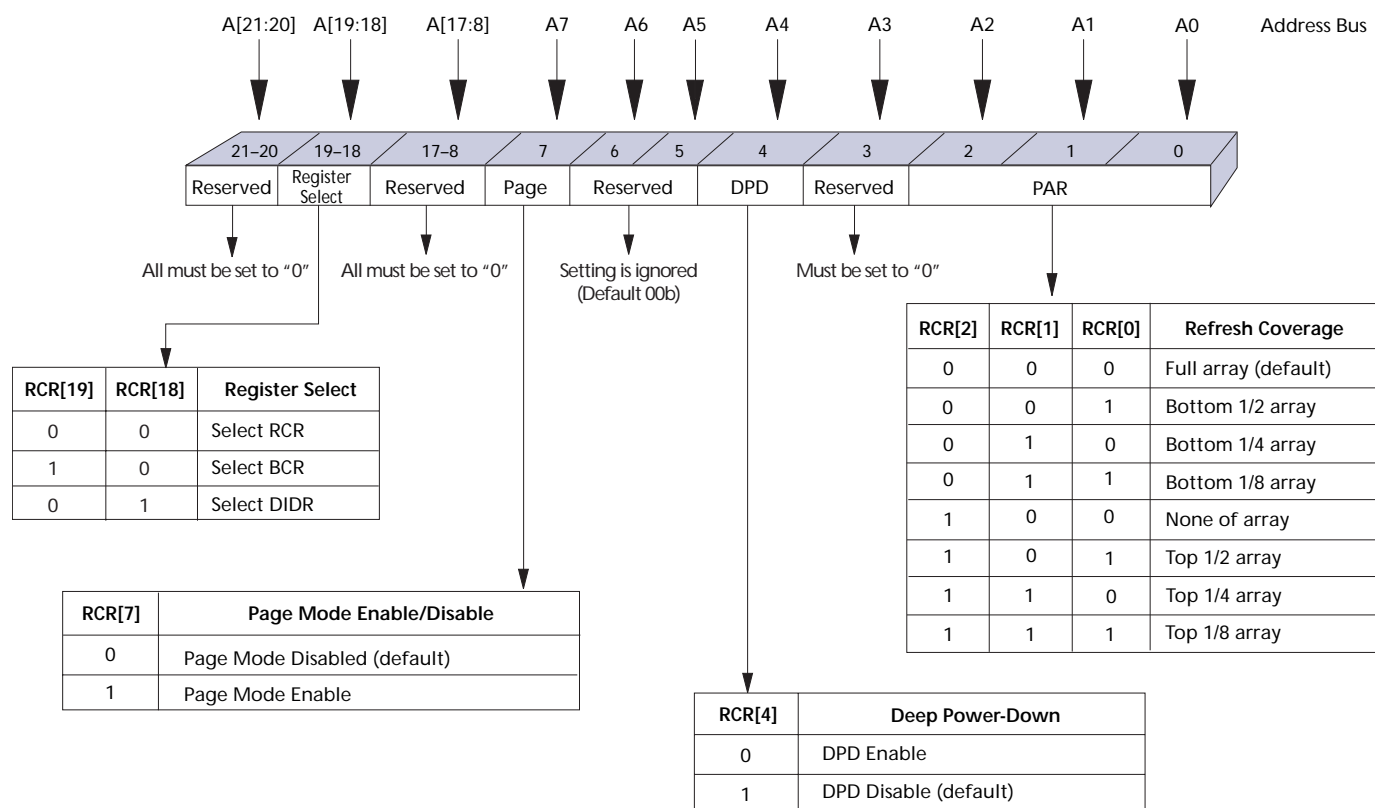



Table 8: 64Mb Address Patterns for PAR (RCR[4] = 1)

RCR[2]	RCR[1]	RCR[0]	Active Section	Address Space	Size	Density
0	0	0	Full die	000000h–3FFFFFFh	4 Meg x 16	64Mb
0	0	1	One-half of die	000000h–1FFFFFFh	2 Meg x 16	32Mb
0	1	0	One-quarter of die	000000h–0FFFFFFh	1 Meg x 16	16Mb
0	1	1	One-eighth of die	000000h–07FFFFh	512K x 16	8Mb
1	0	0	None of die	0	0 Meg x 16	0Mb
1	0	1	One-half of die	200000h–3FFFFFFh	2 Meg x 16	32Mb
1	1	0	One-quarter of die	300000h–3FFFFFFh	1 Meg x 16	16Mb
1	1	1	One-eighth of die	380000h–3FFFFFFh	512K x 16	8Mb

Deep Power-Down (RCR[4]) Default = DPD Disabled

The deep power-down bit enables and disables all refresh-related activity. This mode is used if the system does not require the storage provided by the CellularRAM device. Any stored data will become corrupted when DPD is enabled. When refresh activity has been re-enabled, the CellularRAM device will require 150µs to perform an initialization procedure before normal operations can resume.

Deep power-down is enabled by setting RCR[4] = 0 and taking CE# HIGH. DPD can be enabled using CRE or the software sequence to access the RCR. Taking CE# LOW for at least 10µs disables DPD and sets RCR[4] = 1; it is not necessary to write to the RCR to disable DPD. BCR and RCR values (other than RCR[4]) are preserved during DPD.

Page Mode Operation (RCR[7]) Default = Disabled

The page mode operation bit determines whether page mode is enabled for asynchronous READ operations. In the power-up default state, page mode is disabled.



Device Identification Register

The DIDR provides information on the device manufacturer, CellularRAM generation, and the specific device configuration. Table 9 describes the bit fields in the DIDR.

The DIDR is accessed with CRE HIGH and A[19:18] = 01b, or through the register access software sequence with DQ = 0002h on the third cycle.

Table 9: Device Identification Register Mapping

Bit Field	DIDR[15]	DIDR[14:11]		DIDR[10:8]	DIDR[7:5]	DIDR[4:0]
Field name	Row length	Device version		Device density	CellularRAM generation	Vendor ID
Bit setting	0b	Bit Setting	Version	010b	010b	00011b
		0000b	1st			
		0001b	2nd			
		0010b	3rd			
(etc.)	(etc.)					
Meaning	128 words			64Mb	CellularRAM 1.5	Micron

Notes: 1. Vendors with 256-word row lengths for CellularRAM 1.5 devices will set DIDR[15] to 1b.



Electrical Characteristics

Table 10: Absolute Maximum Ratings

Parameter	Rating	
Voltage to any ball except Vcc, VccQ supply relative to Vss	-0.5V to (4.0V or VccQ + 0.3V, whichever is less) ¹	
Voltage on Vcc supply relative to Vss	-0.2V to +2.45V	
Voltage on VccQ supply relative to Vss	-0.2V to +4.0V	
Storage temperature (plastic)	-55°C to +150°C	
Operating temperature (case)	Wireless	-30°C to +85°C
	Industrial	-40°C to +85°C
Soldering temperature and time:10s (solder ball only)	+260°C	

Notes: 1. This exceeds the CellularRAM Workgroup 1.5 specification of -0.3V to VccQ + 0.3V.

Stresses greater than those listed may cause permanent damage to the device. This is a stress rating only, and functional operation of the device at these or any other conditions above those indicated in the operational sections of this specification is not implied. Exposure to absolute maximum rating conditions for extended periods may affect reliability.



64Mb: 4 Meg x 16 Async/Page/Burst CellularRAM 1.5 Memory Electrical Characteristics

Table 11: Electrical Characteristics and Operating Conditions

 Wireless temperature ($-30^{\circ}\text{C} < T_C < +85^{\circ}\text{C}$); industrial temperature ($-40^{\circ}\text{C} < T_C < +85^{\circ}\text{C}$)

Description	Conditions	Symbol	Min	Max	Unit	Notes
Supply voltage		V _{CC}	1.7	1.95	V	
I/O supply voltage		V _{CCQ}	1.7	3.6	V	1
Input high voltage		V _{IH}	V _{CCQ} - 0.4	V _{CCQ} + 0.2	V	2
Input low voltage		V _{IL}	-0.2	0.4	V	3
Output high voltage	I _{OH} = -0.2mA	V _{OH}	0.8 V _{CCQ}		V	4
Output low voltage	I _{OL} = +0.2mA	V _{OL}		0.2 V _{CCQ}	V	4
Input leakage current	V _{IN} = 0 to V _{CCQ}	I _{LI}		1	μA	
Output leakage current	OE# = V _{IH} or chip disabled	I _{LO}		1	μA	

- Notes:
1. V_{CCQ} (MAX) exceeds the CellularRAM Workgroup specification of 1.95V.
 2. Input signals may overshoot to V_{CCQ} + 1.0V for periods less than 2ns during transitions.
 3. Input signals may undershoot to V_{SS} - 1.0V for periods less than 2ns during transitions.
 4. BCR[5:4] = 01b (default setting of one-half drive strength).

Table 12: Operating Conditions

 Wireless temperature ($-30^{\circ}\text{C} < T_C < +85^{\circ}\text{C}$); industrial temperature ($-40^{\circ}\text{C} < T_C < +85^{\circ}\text{C}$)

Operating Current	Conditions	Symbol	Typ	Max	Unit	Notes
Asynchronous random READ/ WRITE	V _{IN} = V _{CCQ} or 0V chip enabled, I _{OUT} = 0	I _{CC1}	-70	25	mA	1
Asynchronous page READ		I _{CC1P}	-70	15	mA	1, 2
Initial access, burst READ/WRITE		I _{CC2}	133 MHz	45	mA	1
			104 MHz	35	mA	
			80 MHz	30	mA	
Continuous burst READ		I _{CC3R}	133 MHz	40	mA	1
			104 MHz	30	mA	
			80 MHz	25	mA	
Continuous burst WRITE		I _{CC3W}	133 MHz	40	mA	1
			104 MHz	35	mA	
			80 MHz	30	mA	
Standby current		V _{IN} = V _{CCQ} or 0V CE# = V _{CCQ}	I _{SB}	Standard	TBD	μA
			Low-power (L)		140	

- Notes:
1. This parameter is specified with the outputs disabled to avoid external loading effects. The user must add the current required to drive output capacitance expected in the actual system.
 2. Micron devices are fully compatible with the CellularRAM Workgroup specification for I_{CC1}: -70 MAX of 18mA.
 3. I_{SB} (MAX) values measured with PAR set to full array and at 85°C. In order to achieve low standby current, all inputs must be driven to either V_{CCQ} or V_{SS}. I_{SB} might be slightly higher for up to 500ms after power-up, or when entering standby mode.
 4. I_{SB} (TYP) is the average I_{SB} at 25°C and V_{CC} = V_{CCQ} = 1.8V. This parameter is verified during characterization, and is not 100 percent tested.



64Mb: 4 Meg x 16 Async/Page/Burst CellularRAM 1.5 Memory Electrical Characteristics

Table 13: Partial-Array Refresh Specifications and Conditions

Description	Conditions	Symbol		Array Partition	Max	Unit
Partial-array refresh standby current	$V_{IN} = V_{CCQ}$ or $0V$, $CE\# = V_{CCQ}$	IPAR	Standard power (no designation)	Full	180	μA
				1/2	160	
				1/4	150	
				1/8	145	
				0	135	
		Low-power option (L)	Full	140	μA	
			1/2	125		
			1/4	115		
			1/8	110		
			0	105		

Notes: 1. IPAR (Max) values measured at 85°C. IPAR might be slightly higher for up to 500ms after changes to the PAR array partition or when entering standby mode. In order to achieve low standby current, all inputs must be driven to either V_{CCQ} or V_{SS} .

Figure 25: Typical Refresh Current vs. Temperature (I_{TCR})



Table 14: Deep Power-Down Specifications

Description	Conditions	Symbol	Typ	Max	Unit
Deep power-down	$V_{IN} = V_{CCQ}$ or $0V$; $V_{CC}, V_{CCQ} = 1.95V$; +85°C	I _{ZZ}	TBD	10	μA

Notes: 1. Typical (TYP) I_{ZZ} value applies across all operating temperatures and voltages.



64Mb: 4 Meg x 16 Async/Page/Burst CellularRAM 1.5 Memory Electrical Characteristics

Table 15: Capacitance

Description	Conditions	Symbol	Min	Max	Unit	Notes
Input capacitance	$T_C = +25^\circ\text{C}; f = 1\text{ MHz}; V_{IN} = 0\text{V}$	C_{IN}	2.0	6	pF	1
Input/output capacitance (DQ)		C_{IO}	3.5	6	pF	1

Notes: 1. These parameters are verified in device characterization and are not 100-percent tested.

Figure 26: AC Input/Output Reference Waveform

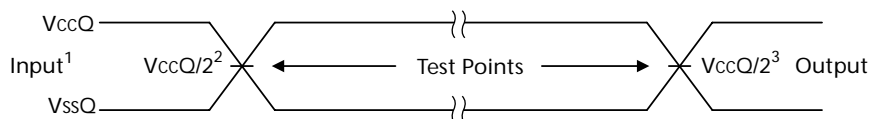

- Notes:
1. AC test inputs are driven at V_{CCQ} for a logic 1 and V_{SSQ} for a logic 0. Input rise and fall times (10% to 90%) < 1.6ns.
 2. Input timing begins at $V_{CCQ}/2$.
 3. Output timing ends at $V_{CCQ}/2$.

Figure 27: AC Output Load Circuit

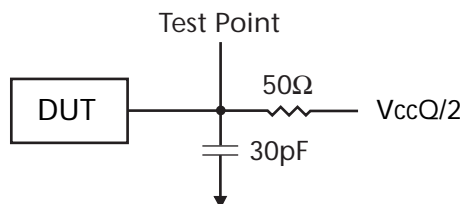

Note: All tests are performed with the outputs configured for default setting of half drive strength (BCR[5:4] = 01b).



64Mb: 4 Meg x 16 Async/Page/Burst CellularRAM 1.5 Memory Timing Requirements

Timing Requirements

Table 16: Asynchronous READ Cycle Timing Requirements

All tests performed with outputs configured for default setting of one-half drive strength (BCR[5:4] = 01b).

Parameter	Symbol	70ns		Unit	Notes
		Min	Max		
Address access time	^t AA		70	ns	
ADV# access time	^t AADV		70	ns	
Page access time	^t APA		20	ns	
Address hold from ADV# HIGH	^t AVH	2		ns	
Address setup to ADV# HIGH	^t AVS	5		ns	
LB#/UB# access time	^t BA		70	ns	
LB#/UB# disable to DQ High-Z output	^t BHZ		8	ns	1
LB#/UB# enable to Low-Z output	^t BLZ	10		ns	2
Maximum CE# pulse width	^t CEM		4	μs	3
CE# LOW to WAIT valid	^t CEW	1	7.5	ns	
Chip select access time	^t CO		70	ns	
CE# LOW to ADV# HIGH	^t CVS	7		ns	
Chip disable to DQ and WAIT High-Z output	^t HZ		8	ns	1
Chip enable to Low-Z output	^t LZ	10		ns	2
Output enable to valid output	^t OE		20	ns	
Output hold from address change	^t OH	5		ns	
Output disable to DQ High-Z output	^t OHZ		8	ns	1
Output enable to Low-Z output	^t OLZ	3		ns	2
PAGE cycle time	^t PC	20		ns	
READ cycle time	^t RC	70		ns	
ADV# pulse width LOW	^t VP	5		ns	

- Notes:
1. Low-Z to High-Z timings are tested with the circuit shown in Figure 27 on page 37. The High-Z timings measure a 100mV transition from either V_{OH} or V_{OL} toward V_{CCQ/2}.
 2. High-Z to Low-Z timings are tested with the circuit shown in Figure 27 on page 37. The Low-Z timings measure a 100mV transition away from the High-Z (V_{CCQ/2}) level toward either V_{OH} or V_{OL}.
 3. Page mode enabled only.



64Mb: 4 Meg x 16 Async/Page/Burst CellularRAM 1.5 Memory Timing Requirements

Table 17: Burst READ Cycle Timing Requirements

All tests performed with outputs configured for default setting of one-half drive strength (BCR[5:4] = 01b).

Parameter	Symbol	-7013 (133 MHz)		-701 (104 MHz)		-708 (80 MHz)		Unit	Notes	
		Min	Max	Min	Max	Min	Max			
Address access time (fixed latency)	^t AA		70		70		70	ns		
ADV# access time (fixed latency)	^t AADV		70		70		70	ns		
Burst to READ access time (variable latency)	^t ABA		35.5		35.9		46.5	ns	1	
CLK to output delay	^t ACLK	Variable LC = 4			5.5		7		9	ns
		Fixed LC = 8			7		7		9	ns
		All other LCs			7		7		9	ns
Address hold from ADV# HIGH (fixed latency)	^t AVH	2		2		2		ns		
Burst OE# LOW to output delay	^t BOE		20		20		20	ns		
CE# HIGH between subsequent burst or mixed-mode operations	^t CBPH	5		5		6		ns	2	
Maximum CE# pulse width	^t CEM		4		4		4	μs	2	
CE# LOW to WAIT valid	^t CEW	1	7.5	1	7.5	1	7.5	ns		
CLK period	^t CLK	7.5		9.62		12.5		ns		
Chip select access time (fixed latency)	^t CO		70		70		70	ns		
CE# setup time to active CLK edge	^t CSP	2.5		3		4		ns		
Hold time from active CLK Edge	^t HD	2		2		2		ns		
Chip disable to DQ and WAIT High-Z output	^t HZ		7		7		7	ns	4	
CLK rise or fall time	^t KHKL		1.2		1.6		1.8	ns		
CLK to WAIT valid	^t KHTL	Variable LC = 4			5.5		7		9	ns
		Fixed LC = 8			7		7		9	ns
		All other LCs			7		7		9	ns
Output hold from CLK	^t KOH	2		2		2		ns		
CLK HIGH or LOW time	^t KP	3		3		4		ns		
Output disable to DQ High-Z output	^t OHZ		7		7		7	ns	3	
Output enable to Low-Z output	^t OLZ	3		3		3		ns	4	
Setup time to active CLK edge	^t SP	2		3		3		ns		

- Notes:
- Values are valid for TCLK (MIN) with no refresh collision: LC= 4 for -7013; LC = 3 for -701 and -708.
 - A refresh opportunity must be provided every ^tCEM. A refresh opportunity is satisfied by either of the following two conditions: a) clocked CE# HIGH, or b) CE# HIGH for longer than 15ns.
 - Low-Z to High-Z timings are tested with the circuit shown in Figure 27 on page 37. The High-Z timings measure a 100mV transition from either V_{OH} or V_{OL} toward V_{CCQ/2}.
 - High-Z to Low-Z timings are tested with the circuit shown in Figure 27 on page 37. The Low-Z timings measure a 100mV transition away from the High-Z (V_{CCQ/2}) level toward either V_{OH} or V_{OL}.



64Mb: 4 Meg x 16 Async/Page/Burst CellularRAM 1.5 Memory Timing Requirements

Table 18: Asynchronous WRITE Cycle Timing Requirements

Parameter	Symbol	70ns		Unit	Notes
		Min	Max		
Address and ADV# LOW setup time	t_{AS}	0		ns	
Address hold from ADV# going HIGH	t_{AVH}	2		ns	
Address setup to ADV# going HIGH	t_{AVS}	5		ns	
Address valid to end of WRITE	t_{AW}	70		ns	
LB#/UB# select to end of WRITE	t_{BW}	70		ns	
CE# LOW to WAIT valid	t_{CEW}	1	7.5	ns	
CE# HIGH between subsequent async operations	t_{CPH}	5		ns	
CE# LOW to ADV# HIGH	t_{CVS}	7		ns	
Chip enable to end of WRITE	t_{CW}	70		ns	
Data hold from WRITE time	t_{DH}	0		ns	
Data WRITE setup time	t_{DW}	20		ns	
Chip disable to WAIT High-Z output	t_{HZ}		8	ns	1
Chip enable to Low-Z output	t_{LZ}	10		ns	2
End WRITE to Low-Z output	t_{OW}	5		ns	2
ADV# pulse width	t_{VP}	5		ns	
ADV# setup to end of WRITE	t_{VS}	70		ns	
WRITE cycle time	t_{WC}	70		ns	
WRITE to DQ High-Z output	t_{WHZ}		8	ns	1
WRITE pulse width	t_{WP}	45		ns	3
WRITE pulse width HIGH	t_{WPH}	10		ns	
WRITE recovery time	t_{WR}	0		ns	

- Notes:
1. Low-Z to High-Z timings are tested with the circuit shown in Figure 27 on page 37. The High-Z timings measure a 100mV transition from either V_{OH} or V_{OL} toward $V_{CCQ/2}$.
 2. High-Z to Low-Z timings are tested with the circuit shown in Figure 27 on page 37. The Low-Z timings measure a 100mV transition away from the High-Z ($V_{CCQ/2}$) level toward either V_{OH} or V_{OL} .
 3. $WE\#$ LOW time must be limited to t_{CEM} (4 μ s).



64Mb: 4 Meg x 16 Async/Page/Burst CellularRAM 1.5 Memory Timing Requirements

Table 19: Burst WRITE Cycle Timing Requirements

Parameter	Symbol	-7013 (133 Mhz)		-701 (104 MHz)		-708 (80 MHz)		Unit	Notes
		Min	Max	Min	Max	Min	Max		
Address and ADV# LOW setup time	t_{AS}	0		0		0		ns	1
Address hold from ADV# HIGH (fixed latency)	t_{AVH}	2		2		2		ns	
CE# HIGH between subsequent burst or mixed-mode operations	t_{CBPH}	5		5		6		ns	2
Maximum CE# pulse width	t_{CEM}		4		4		4	μ s	2
CE# LOW to WAIT valid	t_{CEW}	1	7.5	1	7.5	1	7.5	ns	
Clock period	t_{CLK}	7.5		9.62		12.5		ns	
CE# setup to CLK active edge	t_{CSP}	2.5		3		4		ns	
Hold time from active CLK edge	t_{HD}	2		2		2		ns	
Chip disable to WAIT High-Z output	t_{WZ}		7		8		8	ns	3
CLK rise or fall time	t_T		1.2		1.6		1.8	ns	
Clock to WAIT valid	t_{KW}		5.5		7		9	ns	
CLK HIGH or LOW time	t_{KH}/t_{KL}	3		3		4		ns	
Setup time to active CLK edge	t_{SP}	2		3		3		ns	

- Notes:
- t_{AS} required if $t_{CSP} > 20$ ns.
 - A refresh opportunity must be provided every t_{CEM} . A refresh opportunity is satisfied by either of the following two conditions: a) clocked CE# HIGH, or b) CE# HIGH for longer than 15ns.
 - Low-Z to High-Z timings are tested with the circuit shown in Figure 27 on page 37. The High-Z timings measure a 100mV transition from either V_{OH} or V_{OL} toward $V_{CCQ/2}$.



Timing Diagrams

Figure 28: Initialization Period

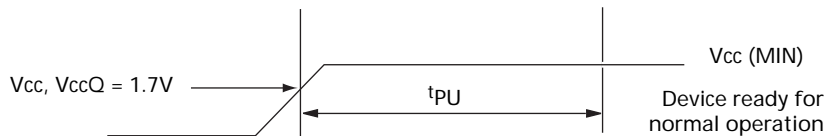

Figure 29: DPD Entry and Exit Timing

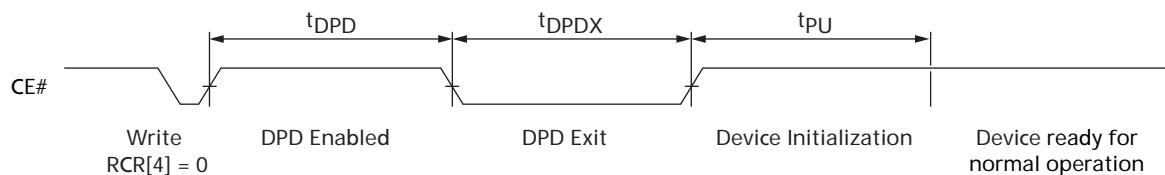

Table 20: Initialization Timing Parameters

Parameter	Symbol	70ns		Unit	Notes
		Min	Max		
Time from DPD entry to DPD exit	t_{DPD}	10		μs	1
CE# LOW time to exit DPD	t_{DPDX}	10		μs	
Initialization period (required before normal operations)	t_{PU}		150	μs	

Notes: 1. The CellularRAM Workgroup 1.5 specification for t_{DPD} is a minimum of 150 μs .



64Mb: 4 Meg x 16 Async/Page/Burst CellularRAM 1.5 Memory Timing Diagrams

Figure 30: Asynchronous READ

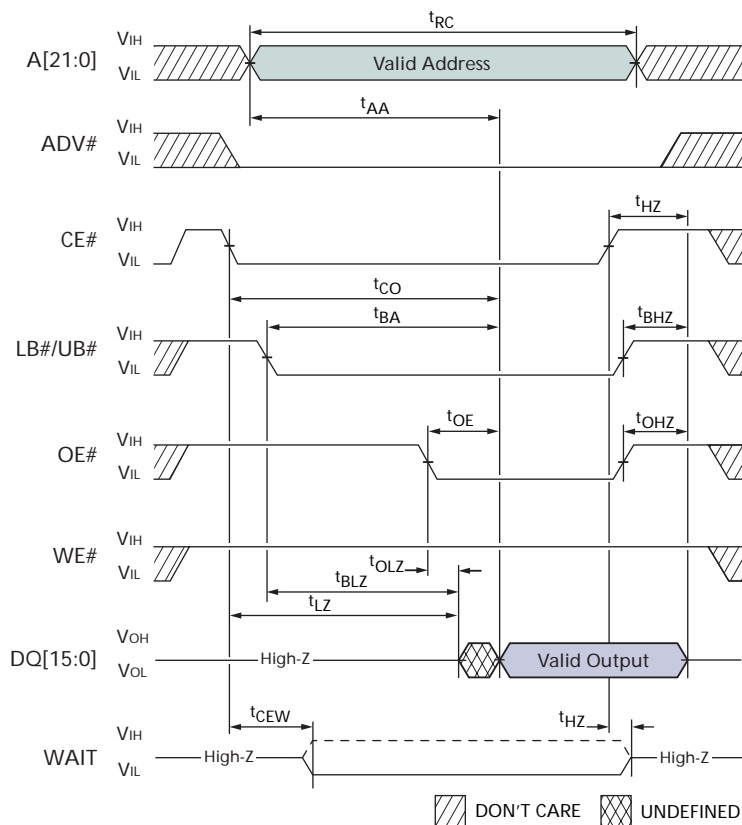



64Mb: 4 Meg x 16 Async/Page/Burst CellularRAM 1.5 Memory Timing Diagrams

Figure 31: Asynchronous READ Using ADV#

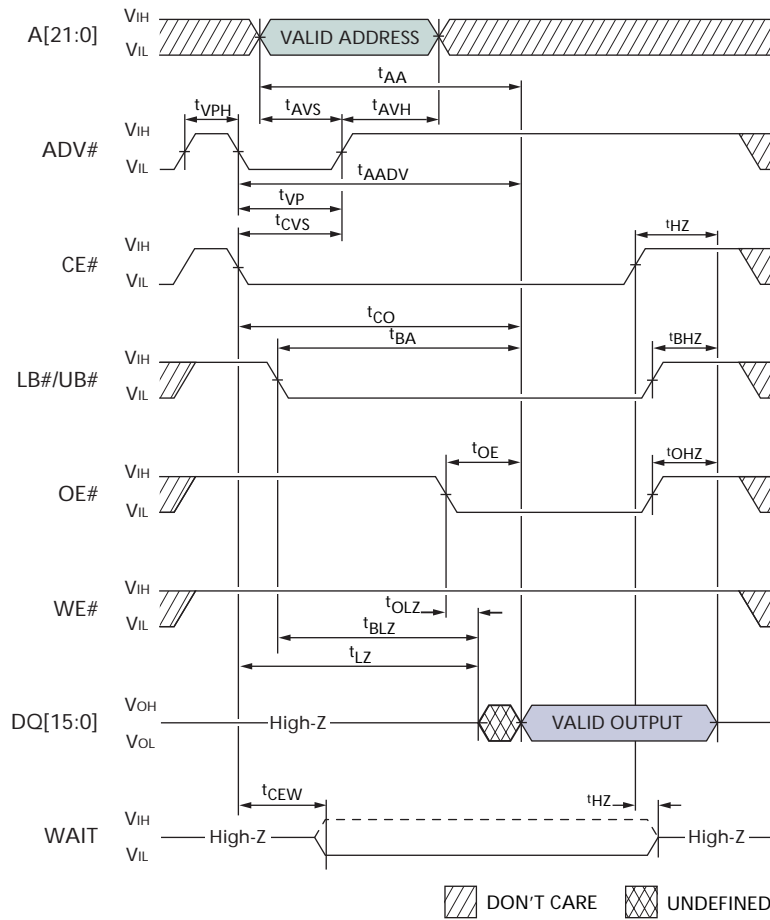



64Mb: 4 Meg x 16 Async/Page/Burst CellularRAM 1.5 Memory Timing Diagrams

Figure 32: Page Mode READ

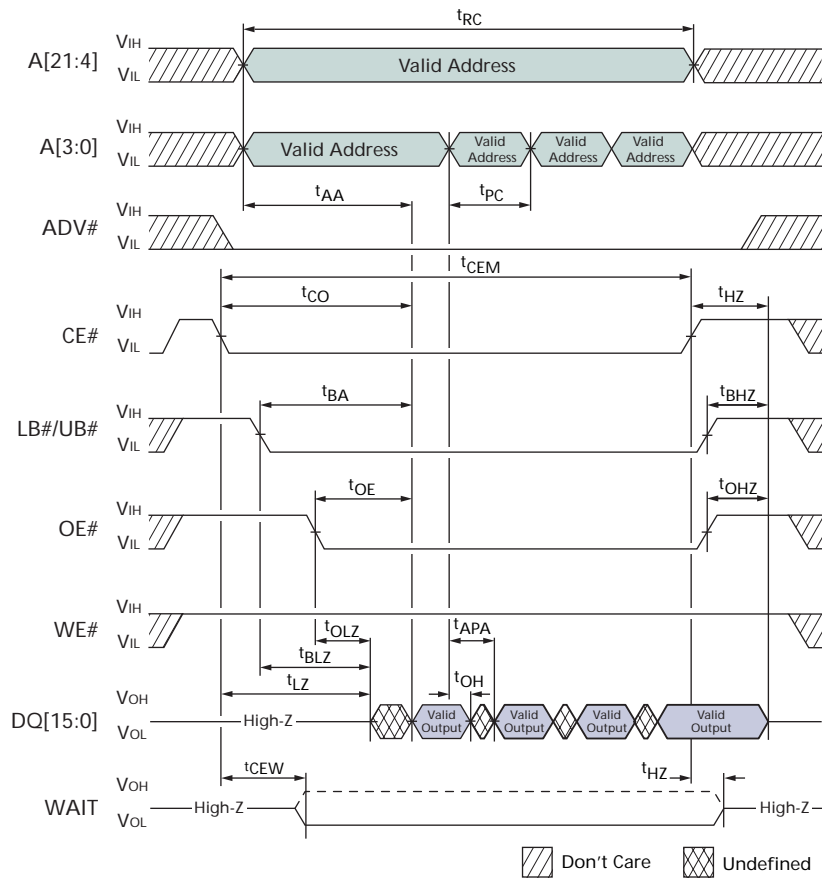



64Mb: 4 Meg x 16 Async/Page/Burst CellularRAM 1.5 Memory Timing Diagrams

Figure 33: Single-Access Burst READ Operation – Variable Latency

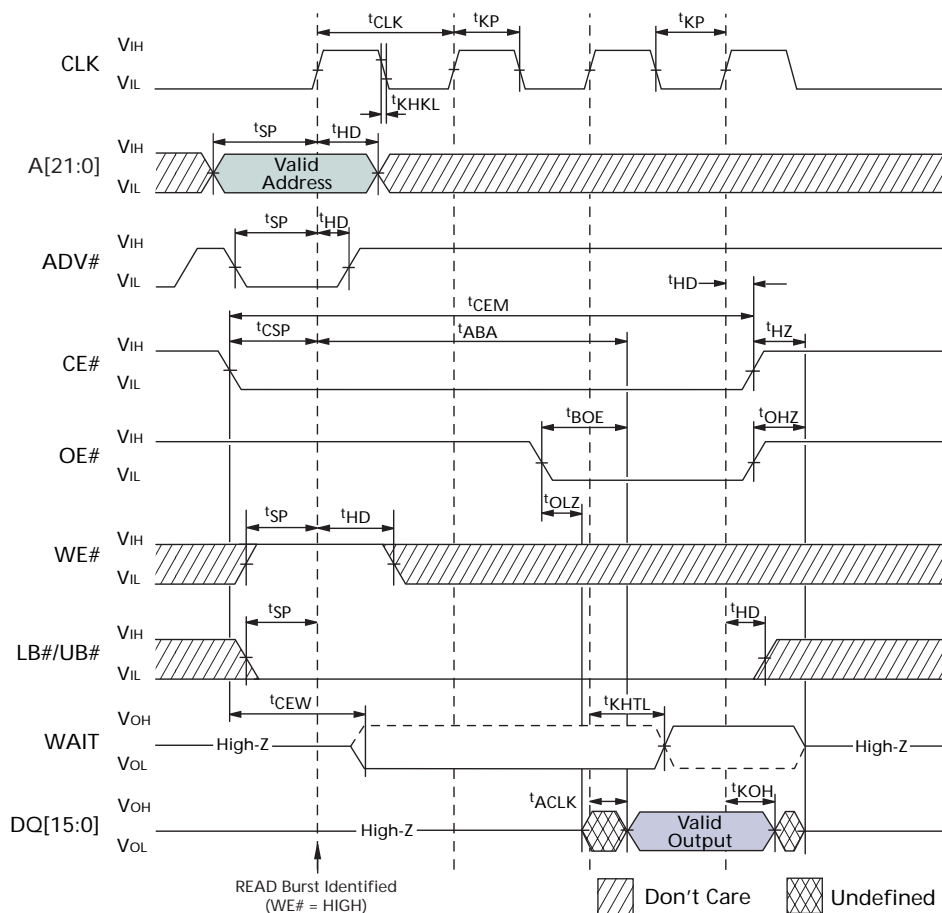

Notes: 1. Non-default BCR settings: latency code two (three clocks); WAIT active LOW; WAIT asserted during delay.



64Mb: 4 Meg x 16 Async/Page/Burst CellularRAM 1.5 Memory Timing Diagrams

Figure 34: 4-Word Burst READ Operation – Variable Latency

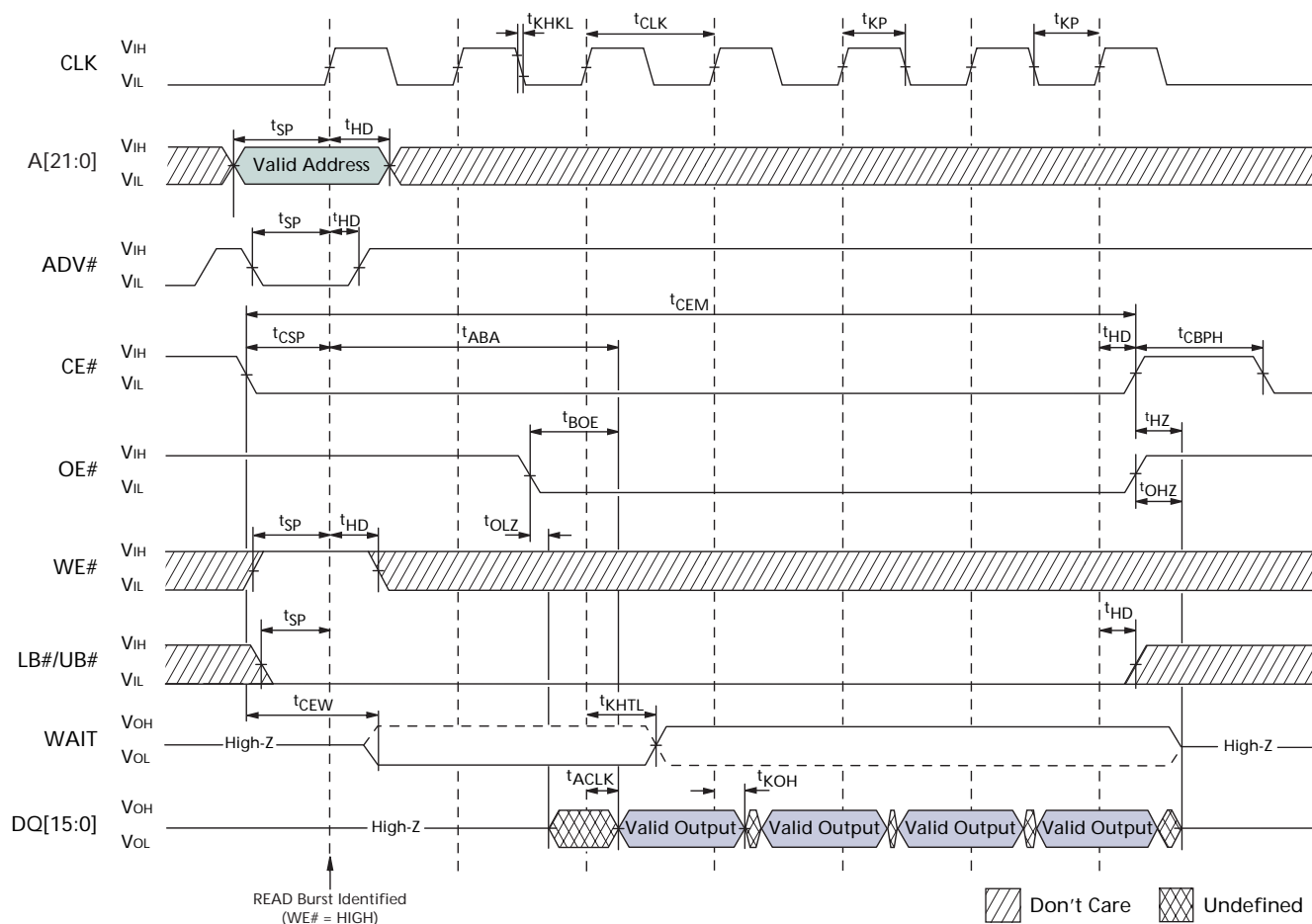

Notes: 1. Non-default BCR settings: latency code two (three clocks); WAIT active LOW; WAIT asserted during delay.



64Mb: 4 Meg x 16 Async/Page/Burst CellularRAM 1.5 Memory Timing Diagrams

Figure 35: Single-Access Burst READ Operation – Fixed Latency

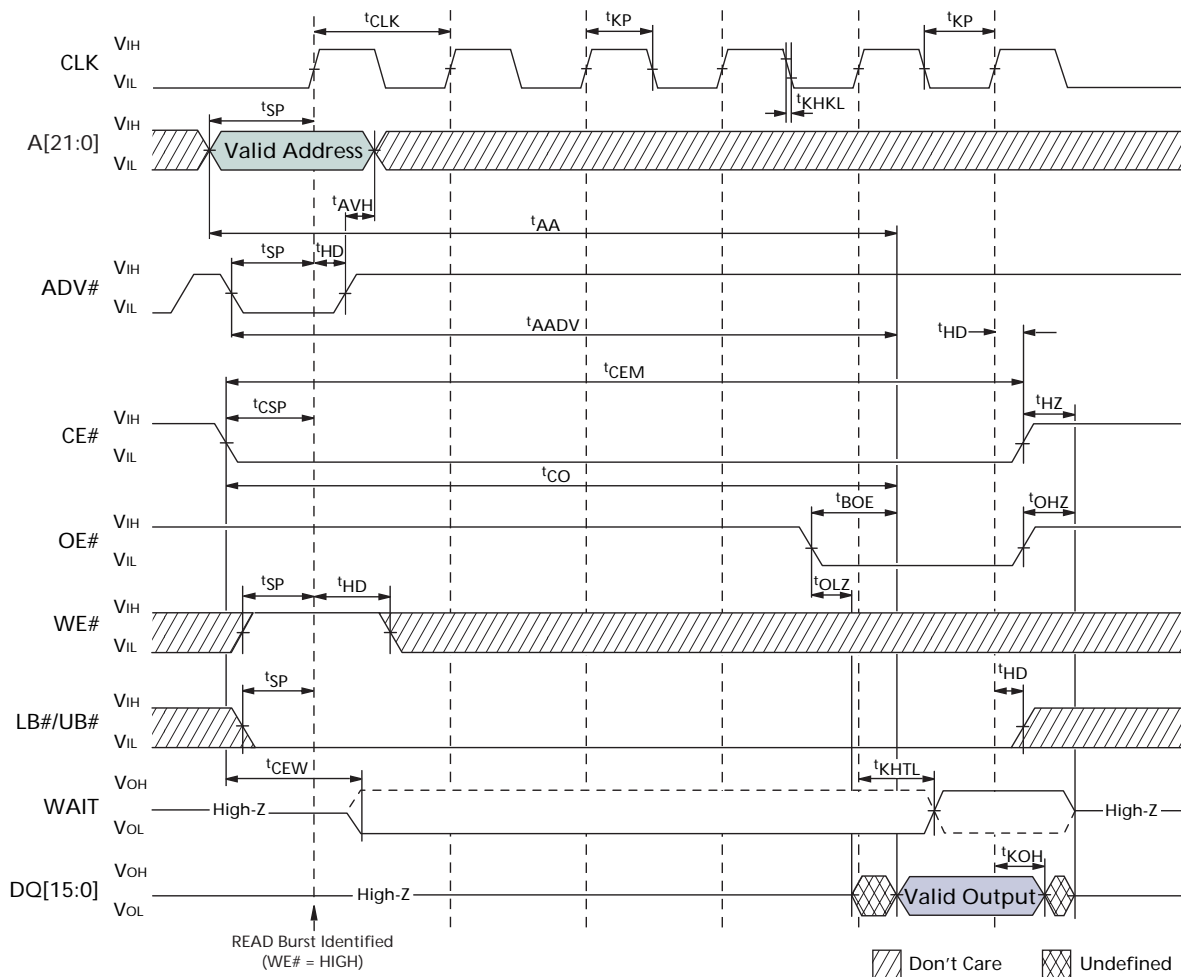

Notes: 1. Non-default BCR settings: Fixed latency; latency code four (five clocks); WAIT active LOW; WAIT asserted during delay.



64Mb: 4 Meg x 16 Async/Page/Burst CellularRAM 1.5 Memory Timing Diagrams

Figure 36: 4-Word Burst READ Operation – Fixed Latency

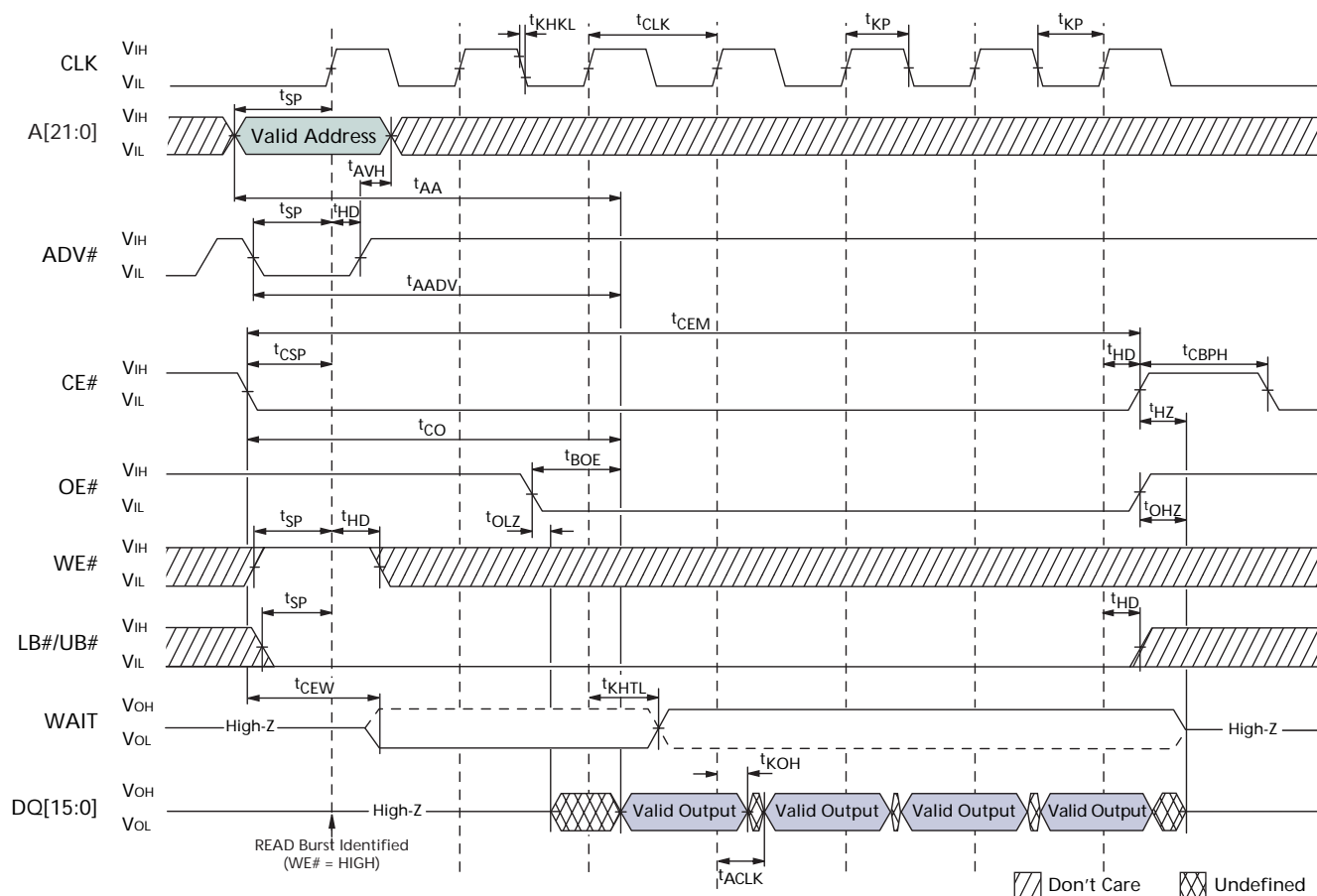

Notes: 1. Non-default BCR settings: Fixed latency; latency code two (three clocks); WAIT active LOW; WAIT asserted during delay.



64Mb: 4 Meg x 16 Async/Page/Burst CellularRAM 1.5 Memory Timing Diagrams

Figure 37: READ Burst Suspend

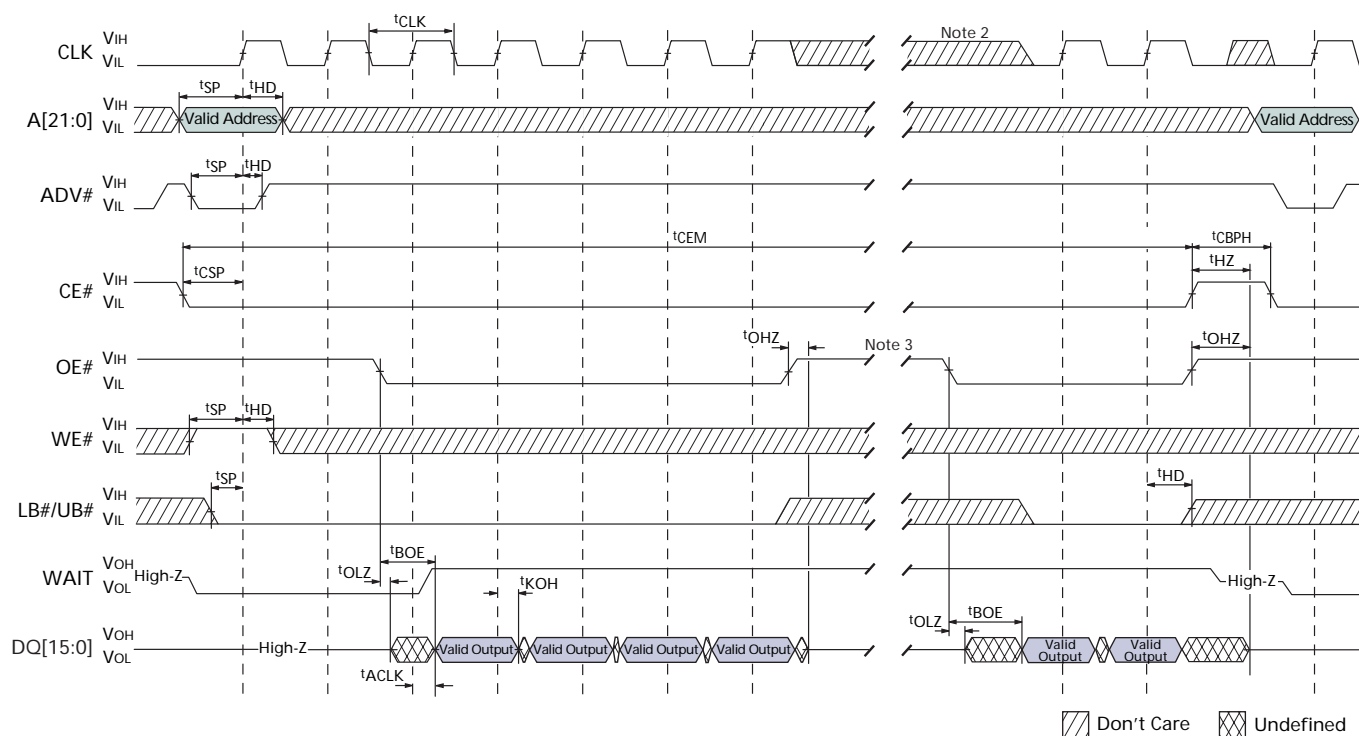

- Notes:
1. Non-default BCR settings for READ burst suspend: Fixed or variable latency; latency code two (three clocks); WAIT active LOW; WAIT asserted during delay.
 2. CLK can be stopped LOW or HIGH, but must be static, with no LOW-to-HIGH transitions during burst suspend.
 3. OE# can stay LOW during burst suspend. If OE# is LOW, DQ[15:0] will continue to output valid data.



64Mb: 4 Meg x 16 Async/Page/Burst CellularRAM 1.5 Memory Timing Diagrams

Figure 38: Burst READ at End-of-Row (Wrap Off)

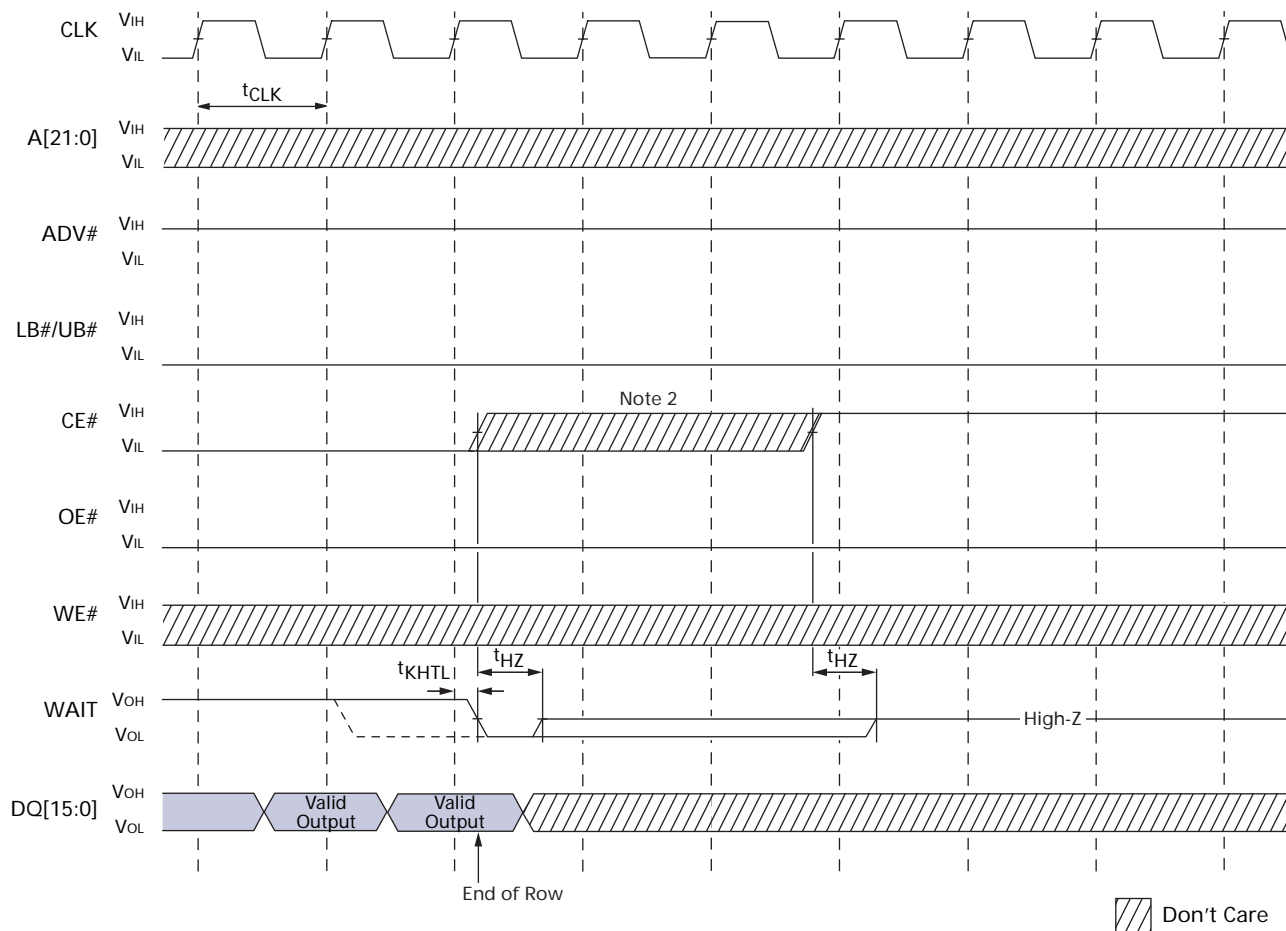

- Notes:
1. Non-default BCR settings for burst READ at end of row: fixed or variable latency; WAIT active LOW; WAIT asserted during delay.
 2. For burst READs, CE# must go HIGH before the third CLK after the WAIT period begins (before the third CLK after WAIT asserts with BCR[8] = 0, or before the fourth CLK after WAIT asserts with BCR[8] = 1). Micron devices are fully compatible with the CellularRAM Workgroup specification that requires CE# to go HIGH one cycle sooner than shown here.



64Mb: 4 Meg x 16 Async/Page/Burst CellularRAM 1.5 Memory Timing Diagrams

Figure 39: CE#-Controlled Asynchronous WRITE

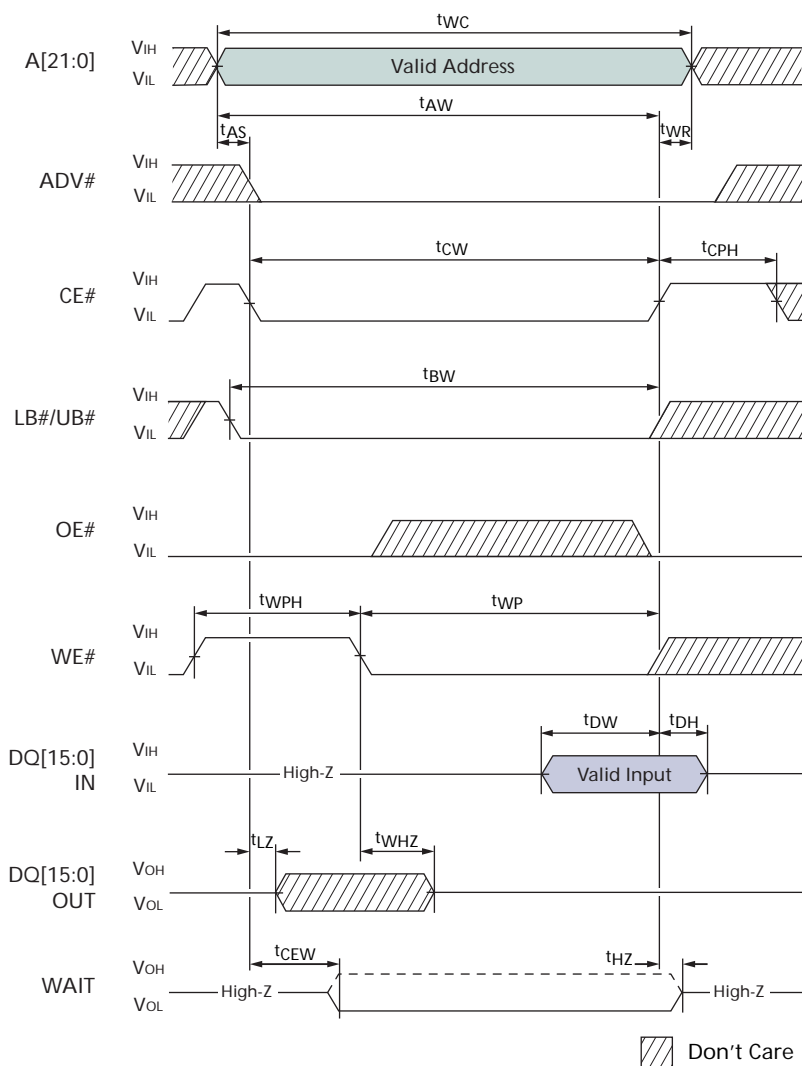



64Mb: 4 Meg x 16 Async/Page/Burst CellularRAM 1.5 Memory Timing Diagrams

Figure 40: LB#/UB#-Controlled Asynchronous WRITE

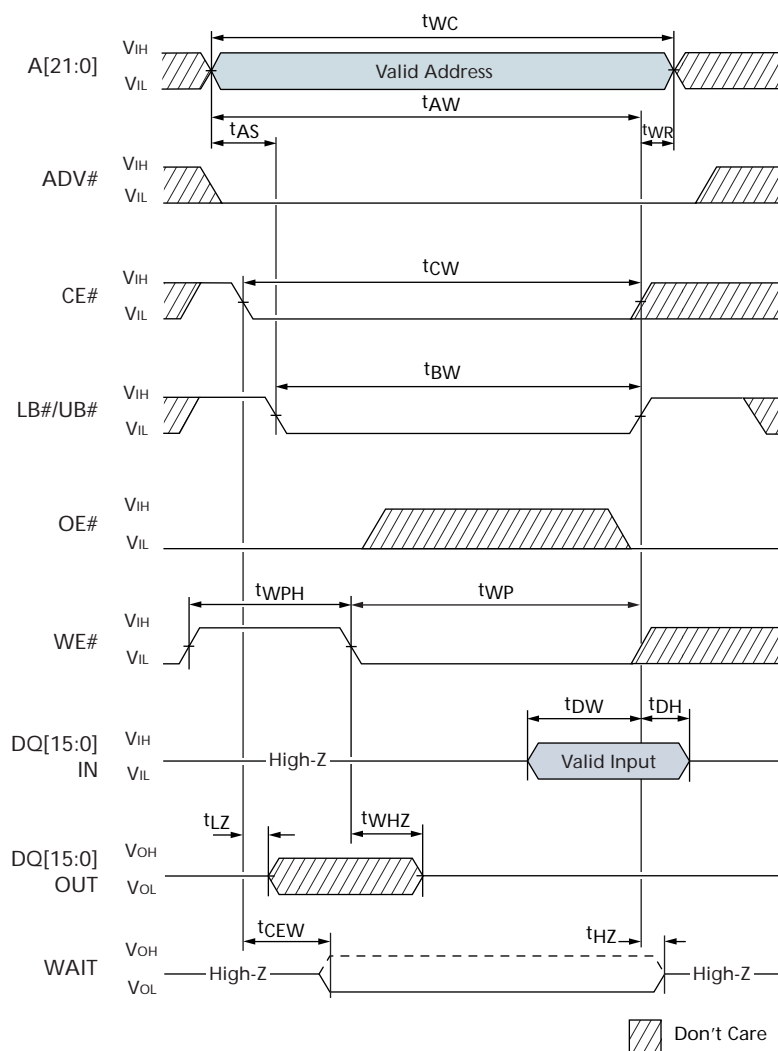



64Mb: 4 Meg x 16 Async/Page/Burst CellularRAM 1.5 Memory Timing Diagrams

Figure 41: WE#-Controlled Asynchronous WRITE

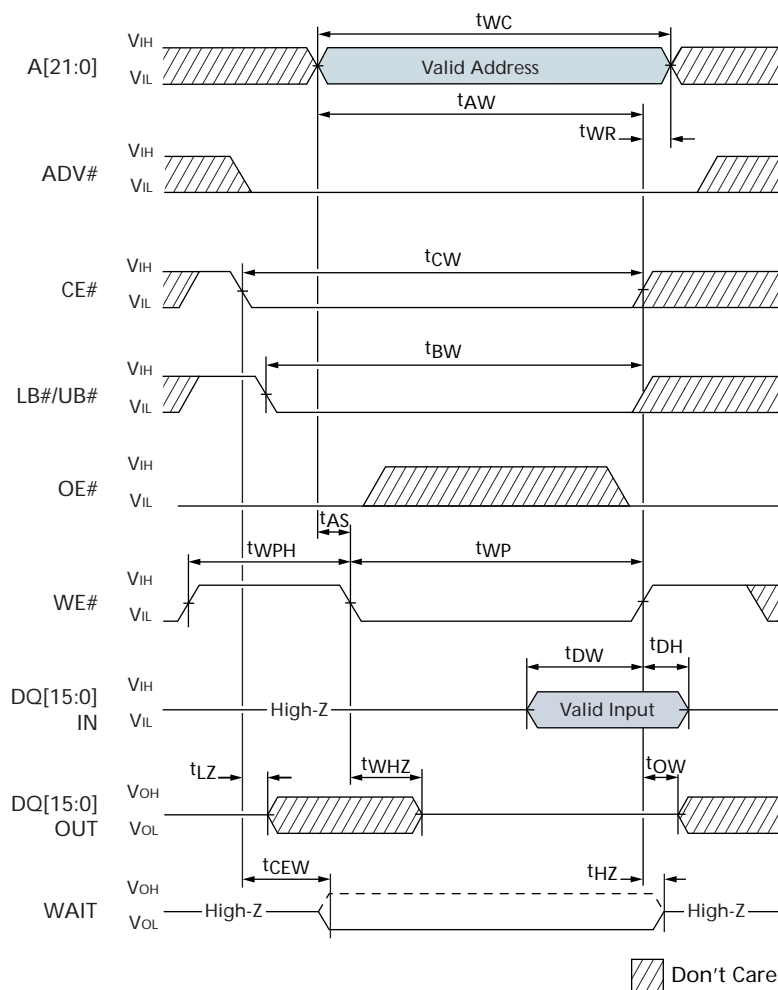



64Mb: 4 Meg x 16 Async/Page/Burst CellularRAM 1.5 Memory Timing Diagrams

Figure 42: Asynchronous WRITE Using ADV#

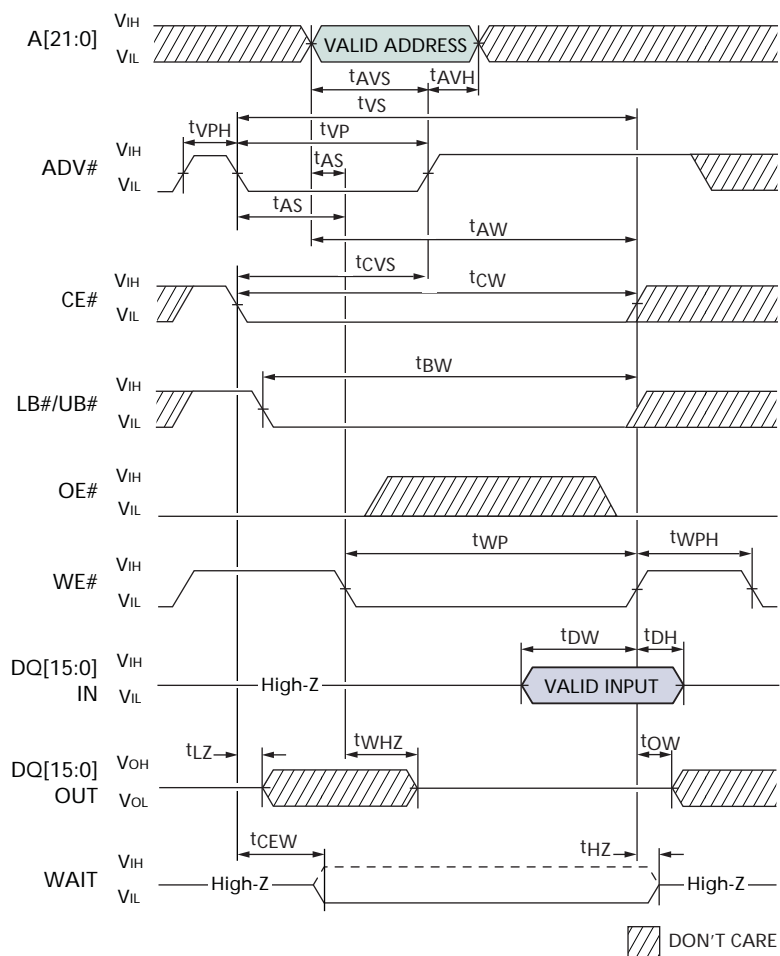



64Mb: 4 Meg x 16 Async/Page/Burst CellularRAM 1.5 Memory Timing Diagrams

Figure 43: Burst WRITE Operation – Variable Latency Mode

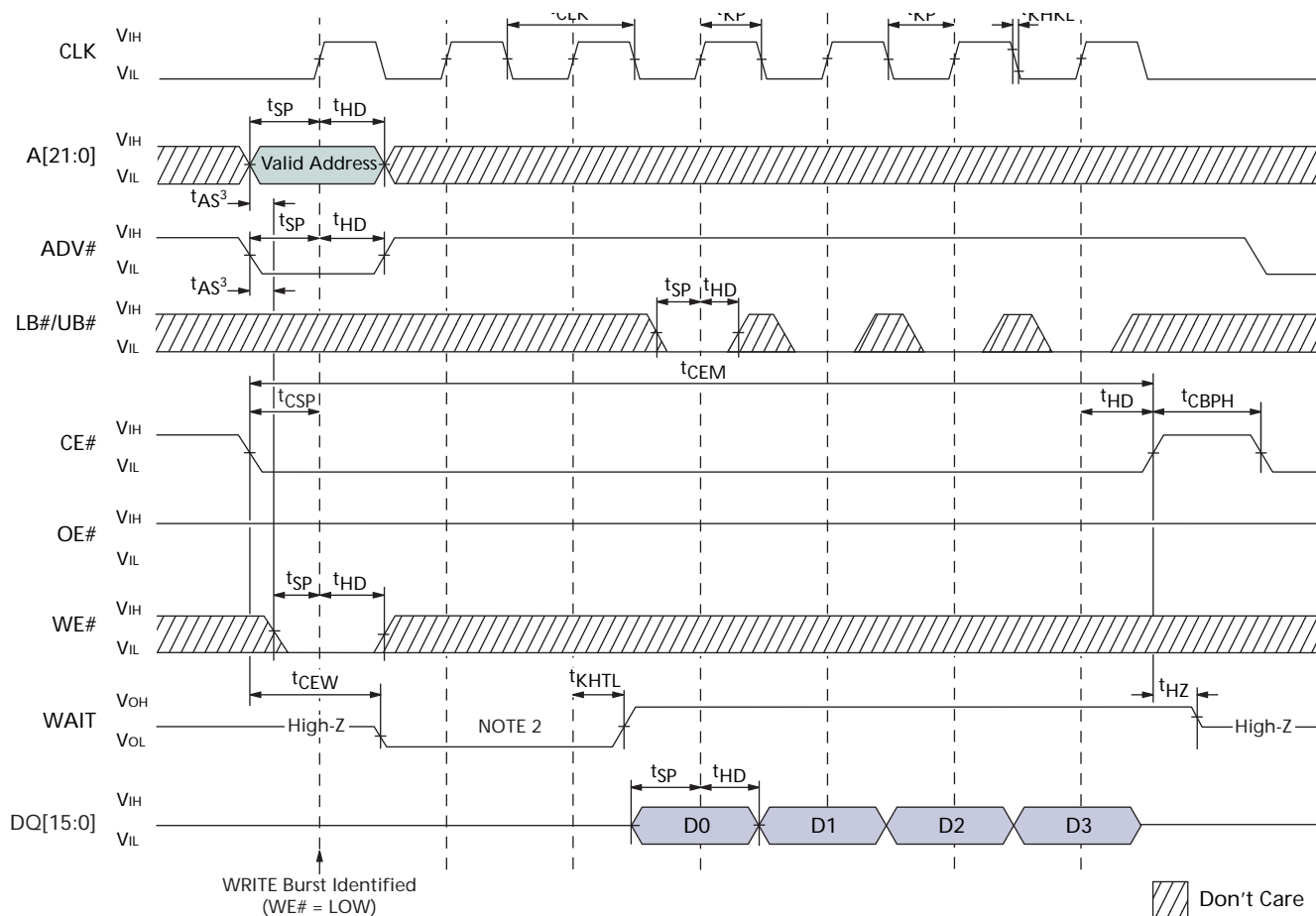

- Notes:
1. Non-default BCR settings for burst WRITE operation in variable latency mode: latency code two (three clocks); WAIT active LOW; WAIT asserted during delay; burst length four; burst wrap enabled.
 2. WAIT asserts for LC cycles for both fixed and variable latency. LC = latency code (BCR[13:11]).
 3. t_{AS} required if $t_{CSP} > 20ns$.



64Mb: 4 Meg x 16 Async/Page/Burst CellularRAM 1.5 Memory Timing Diagrams

Figure 44: Burst WRITE Operation – Fixed Latency Mode

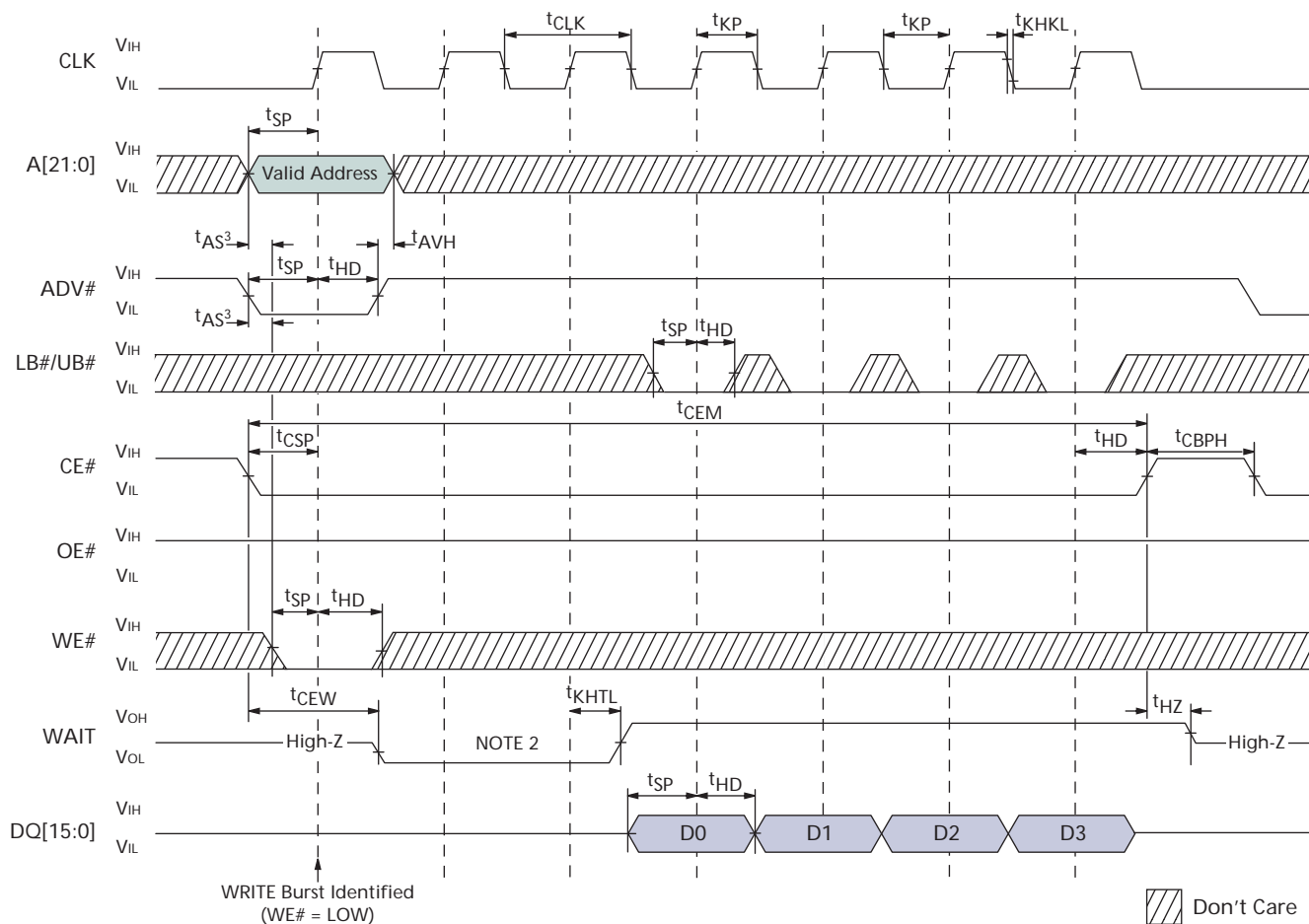

- Notes:
1. Non-default BCR settings for burst WRITE operation in fixed latency mode: Fixed latency; latency code two (three clocks); WAIT active LOW; WAIT asserted during delay; burst length four; burst wrap enabled.
 2. WAIT asserts for LC cycles for both fixed and variable latency. LC = latency code (BCR[13:11]).
 3. t_{AS} required if $t_{CSP} > 20ns$.



64Mb: 4 Meg x 16 Async/Page/Burst CellularRAM 1.5 Memory Timing Diagrams

Figure 45: Burst WRITE at End of Row (Wrap Off)

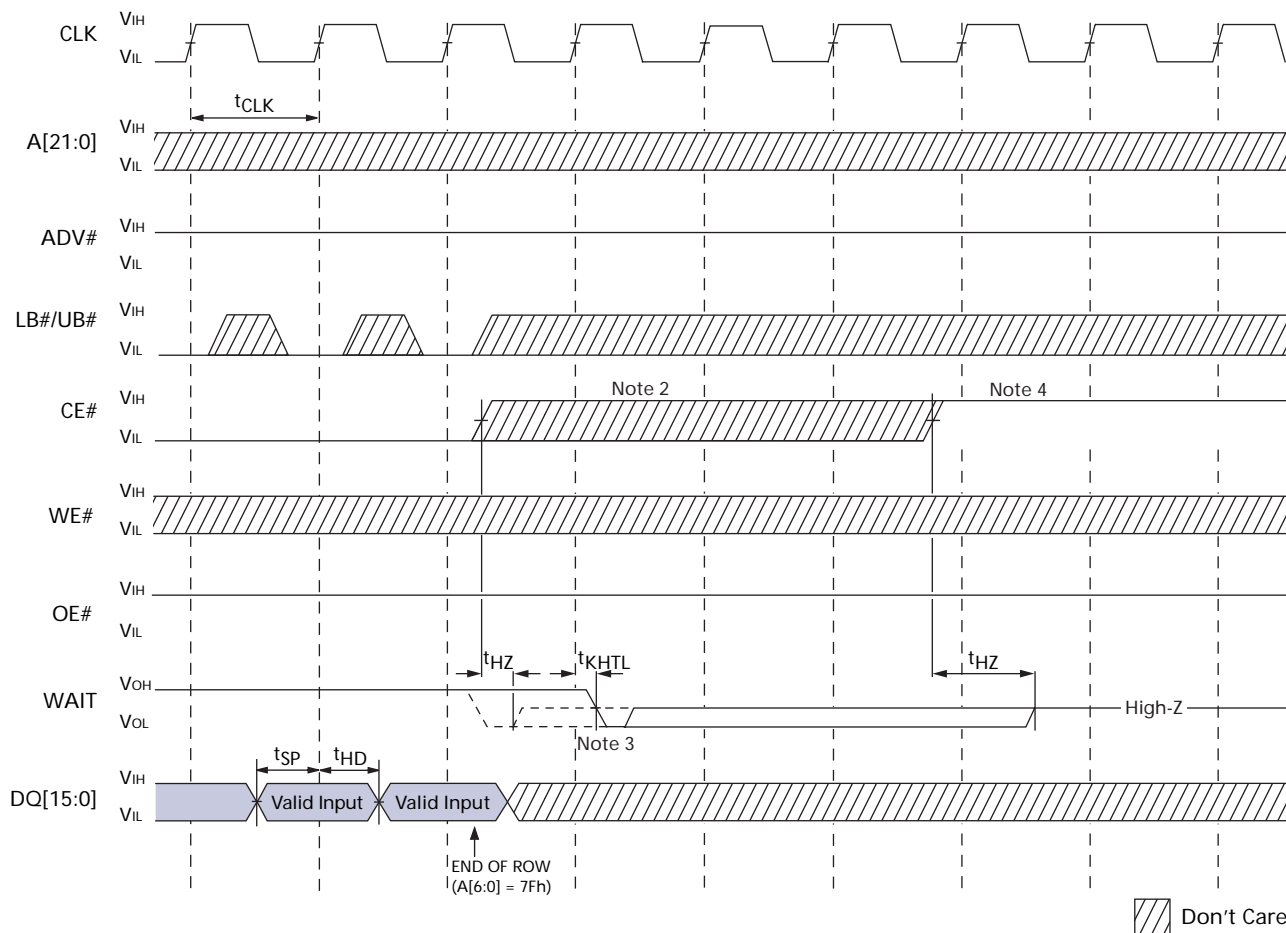

- Notes:
1. Non-default BCR settings for burst WRITE at end of row: fixed or variable latency; WAIT active LOW; WAIT asserted during delay.
 2. For burst WRITES, CE# must go HIGH before the third CLK after the WAIT period begins (before the third CLK after WAIT asserts with BCR[8] = 0, or before the fourth CLK after WAIT asserts with BCR[8] = 1). Micron devices are fully compatible with the CellularRAM Workgroup specification that requires CE# to go HIGH one cycle sooner than shown here.
 3. Devices from different CellularRAM vendors can assert WAIT so that the end-of-row data is input one cycle before the WAIT period begins (as shown, solid line), or the same cycle that asserts WAIT. This difference in behavior will not be noticed by controllers that monitor WAIT or that use WAIT to abort on an end-of-row condition.
 4. Micron devices are fully compatible with the CellularRAM Workgroup specification that requires CE# to go HIGH one cycle sooner than shown here.



64Mb: 4 Meg x 16 Async/Page/Burst CellularRAM 1.5 Memory Timing Diagrams

Figure 46: Burst WRITE Followed by Burst READ

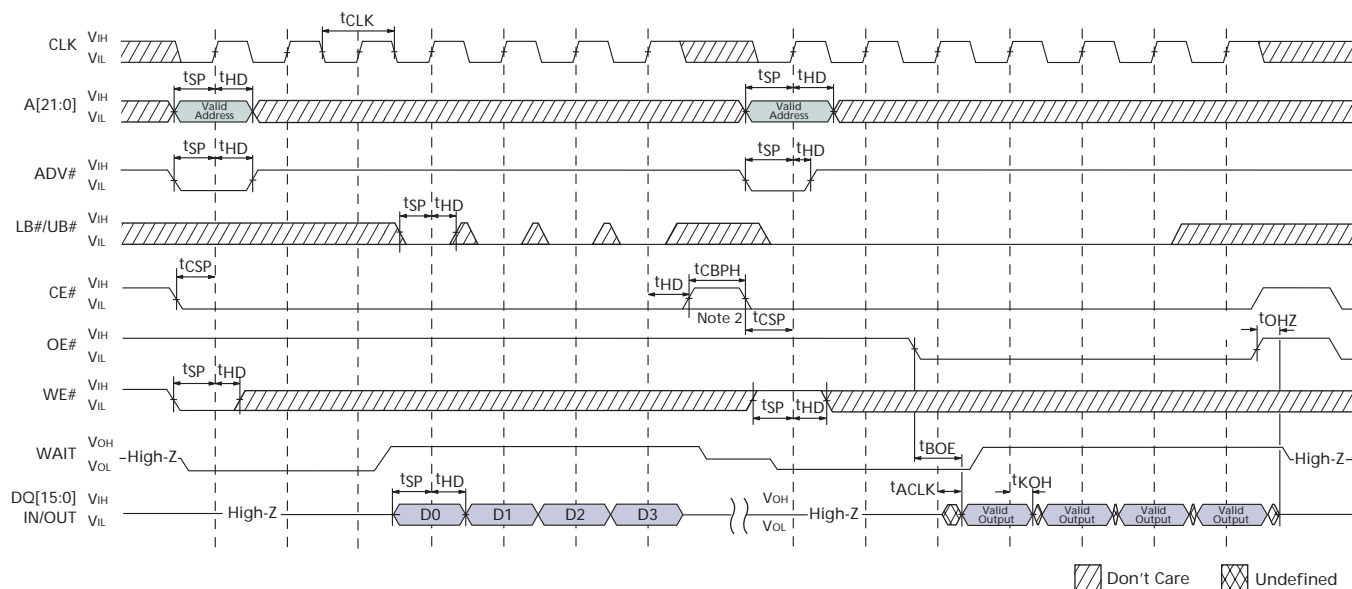

- Notes:
1. Non-default BCR settings for burst WRITE followed by burst READ: Fixed or variable latency; latency code two (three clocks); WAIT active LOW; WAIT asserted during delay.
 2. A refresh opportunity must be provided every t_{CEM} . A refresh opportunity is satisfied by either of the following two conditions: a) clocked CE# HIGH, or b) CE# HIGH for longer than 15ns. CE# can stay LOW between burst READ and burst WRITE operations, but CE# must not remain LOW longer than t_{CEM} . See burst interrupt diagrams (Figures 47–49, on pages 60–62) for cases where CE# stays LOW between bursts.



64Mb: 4 Meg x 16 Async/Page/Burst CellularRAM 1.5 Memory Timing Diagrams

Figure 47: Burst READ Interrupted by Burst READ or WRITE

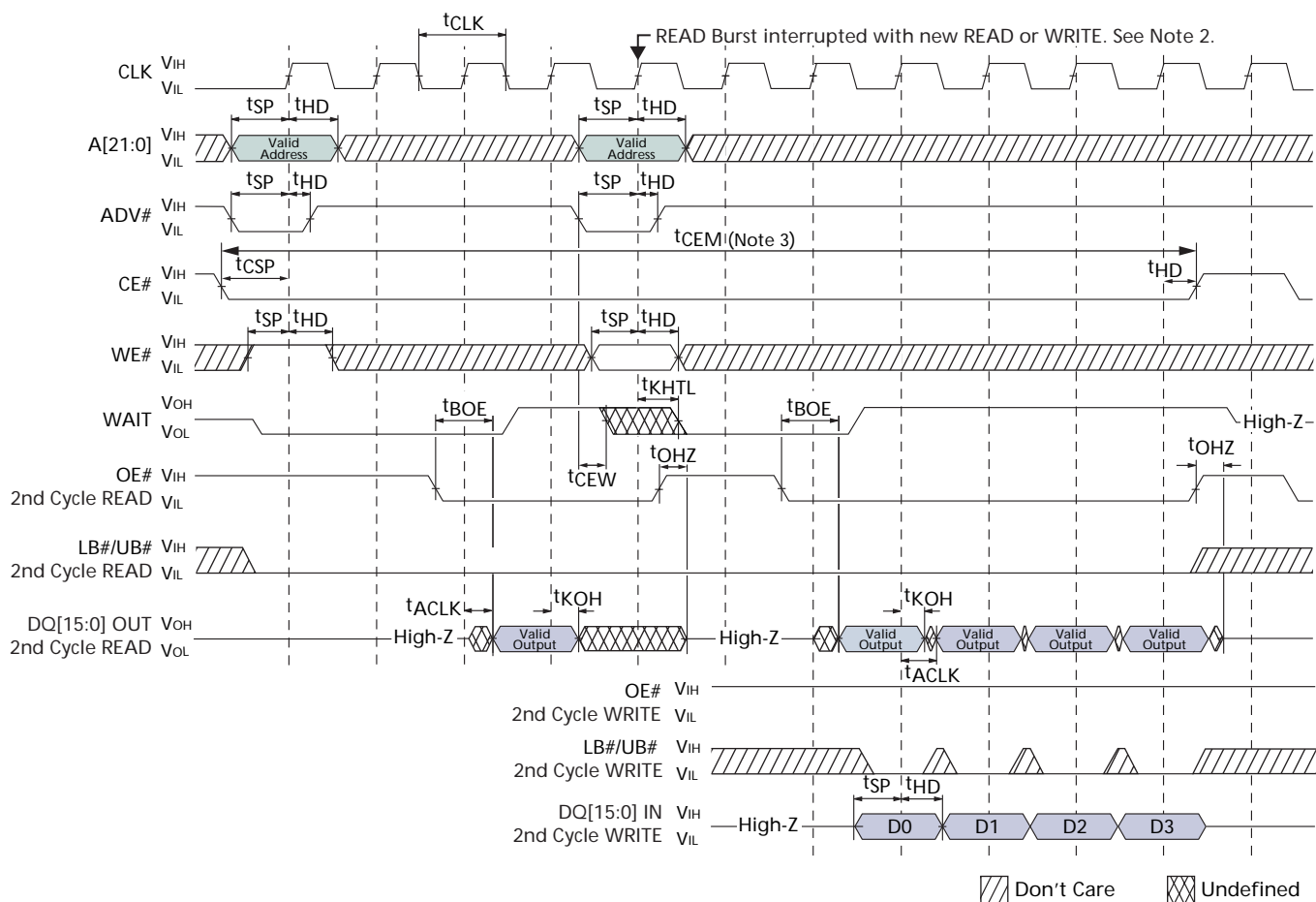

- Notes:
1. Non-default BCR settings for burst READ interrupted by burst READ or WRITE: Fixed or variable latency; latency code two (three clocks); WAIT active LOW; WAIT asserted during delay. All bursts shown for variable latency; no refresh collision.
 2. Burst interrupt shown on first allowable clock (i.e., after the first data received by controller).



64Mb: 4 Meg x 16 Async/Page/Burst CellularRAM 1.5 Memory Timing Diagrams

Figure 48: Burst WRITE Interrupted by Burst WRITE or READ – Variable Latency Mode

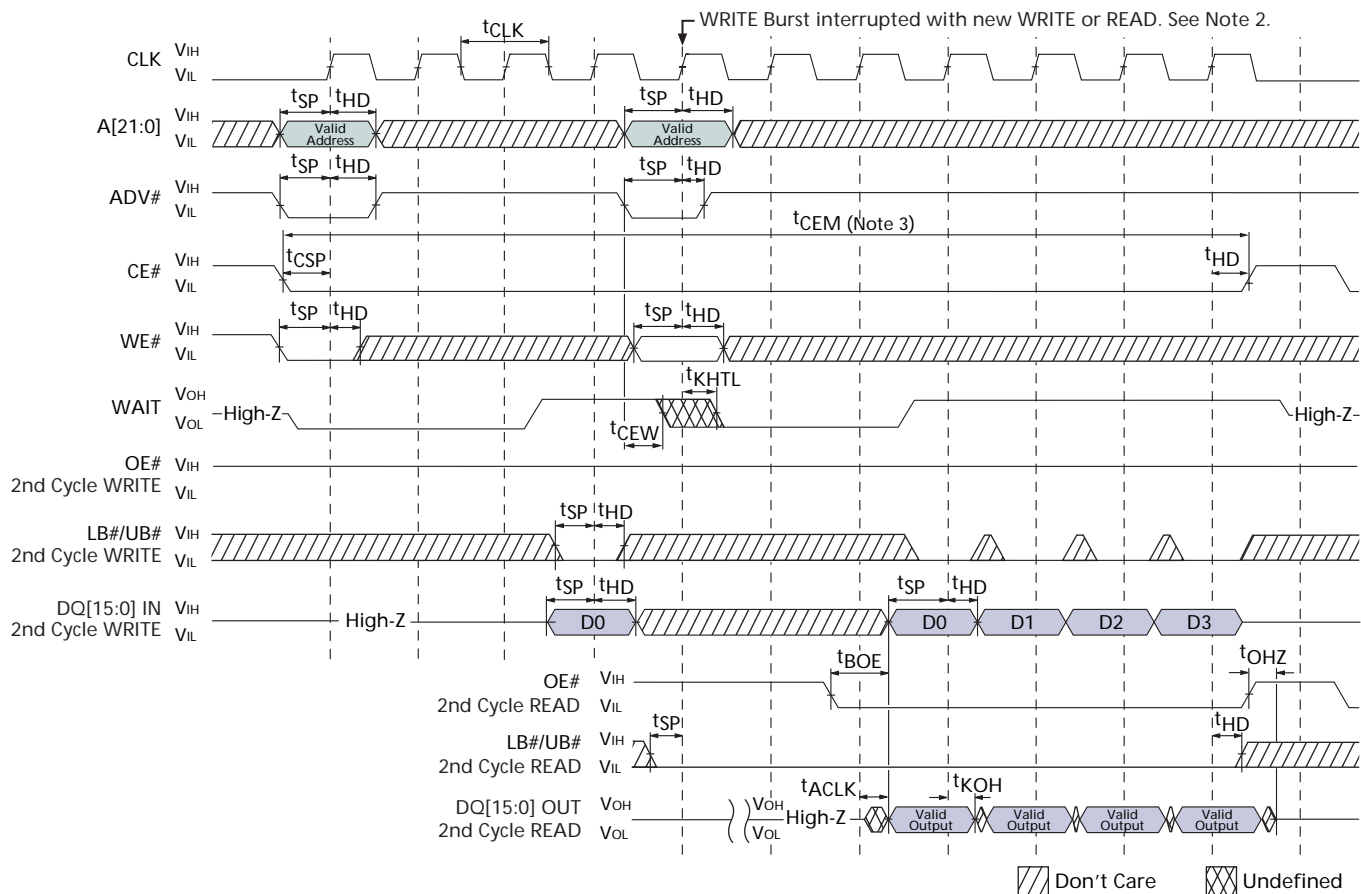

- Notes:
1. Non-default BCR settings for burst WRITE interrupted by burst WRITE or READ in variable latency mode: Fixed or variable latency; latency code two (three clocks); WAIT active LOW; WAIT asserted during delay. All bursts shown for variable latency; no refresh collision.
 2. Burst interrupt shown on first allowable clock (i.e., after first data word written).
 3. CE# can stay LOW between burst operations, but CE# must not remain LOW longer than t_{CEM} .



64Mb: 4 Meg x 16 Async/Page/Burst CellularRAM 1.5 Memory Timing Diagrams

Figure 49: Burst WRITE Interrupted by Burst WRITE or READ – Fixed Latency Mode

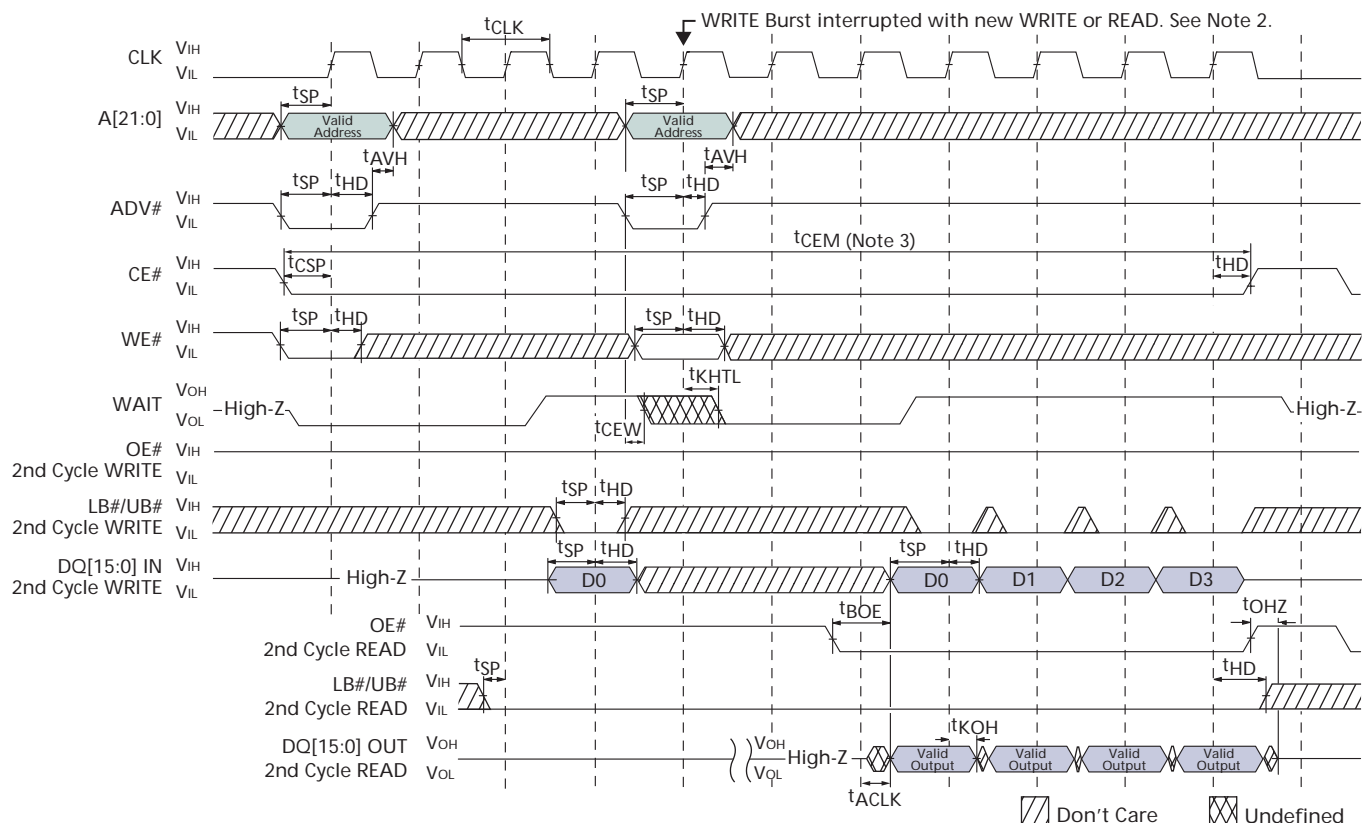

- Notes:
1. Non-default BCR settings for burst WRITE interrupted by burst WRITE or READ in fixed latency mode: Fixed latency; latency code two (three clocks); WAIT active LOW; WAIT asserted during delay.
 2. Burst interrupt shown on first allowable clock (i.e., after first data word written).
 3. CE# can stay LOW between burst operations, but CE# must not remain LOW longer than tCEM.



64Mb: 4 Meg x 16 Async/Page/Burst CellularRAM 1.5 Memory Timing Diagrams

Figure 50: Asynchronous WRITE Followed by Burst READ

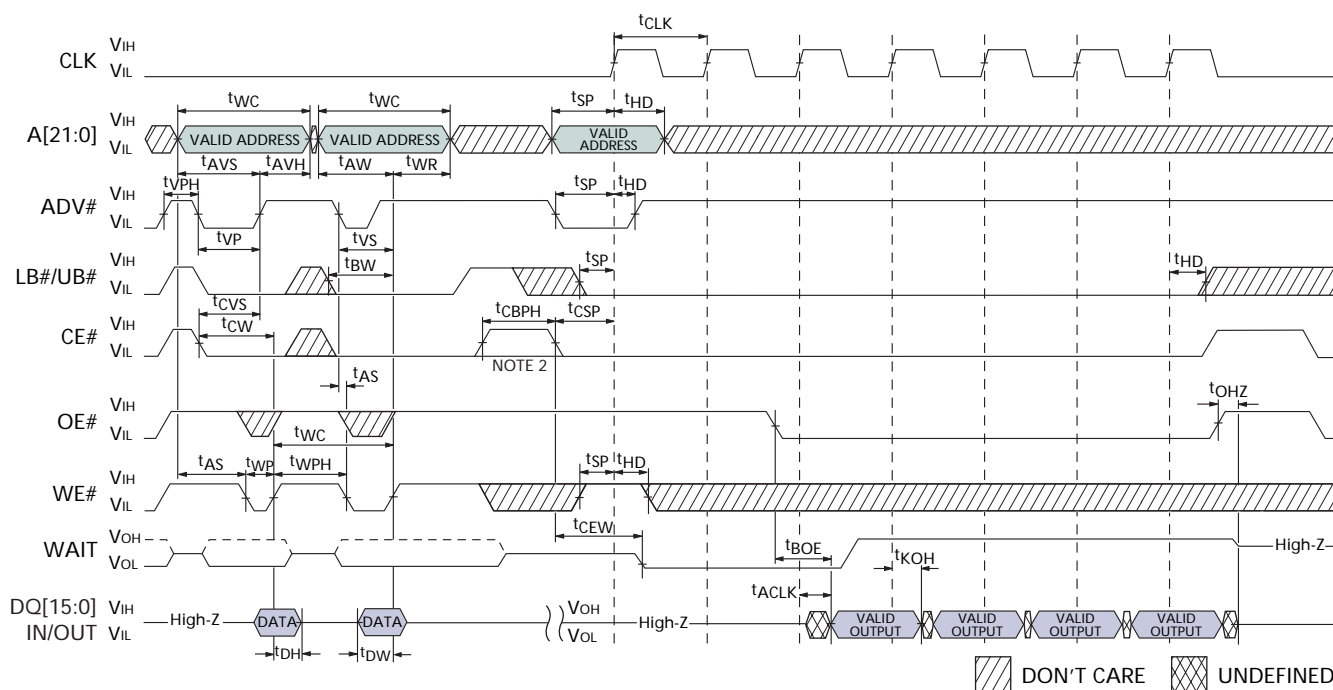

- Notes:
1. Non-default BCR settings for asynchronous WRITE followed by burst READ: Fixed or variable latency; latency code two (three clocks); WAIT active LOW; WAIT asserted during delay.
 2. When transitioning between asynchronous and variable-latency burst operations, CE# must go HIGH. CE# can stay LOW when transitioning to fixed-latency burst READs. A refresh opportunity must be provided every t_{CEM} . A refresh opportunity is satisfied by either of the following two conditions: a) clocked CE# HIGH, or b) CE# HIGH for longer than 15ns.



64Mb: 4 Meg x 16 Async/Page/Burst CellularRAM 1.5 Memory Timing Diagrams

Figure 52: Burst READ Followed by Asynchronous WRITE (WE#-Controlled)

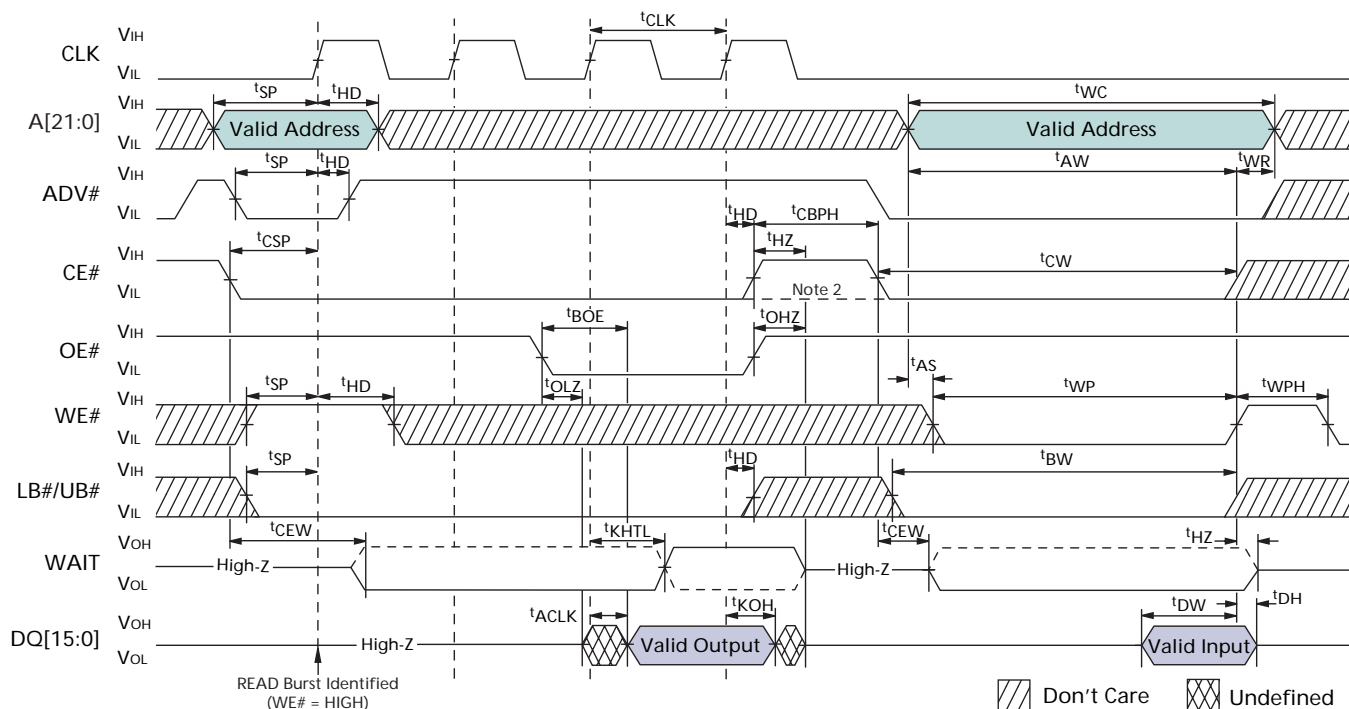

- Notes:
1. Non-default BCR settings for burst READ followed by asynchronous WE#-controlled WRITE: Fixed or variable latency; latency code two (three clocks); WAIT active LOW; WAIT asserted during delay.
 2. When transitioning between asynchronous and variable-latency burst operations, CE# must go HIGH. CE# can stay LOW when transitioning from fixed-latency burst READs. A refresh opportunity must be provided every t_{CEM} . A refresh opportunity is satisfied by either of the following two conditions: a) clocked CE# HIGH, or b) CE# HIGH for longer than 15ns.



64Mb: 4 Meg x 16 Async/Page/Burst CellularRAM 1.5 Memory Timing Diagrams

Figure 53: Burst READ Followed by Asynchronous WRITE Using ADV#

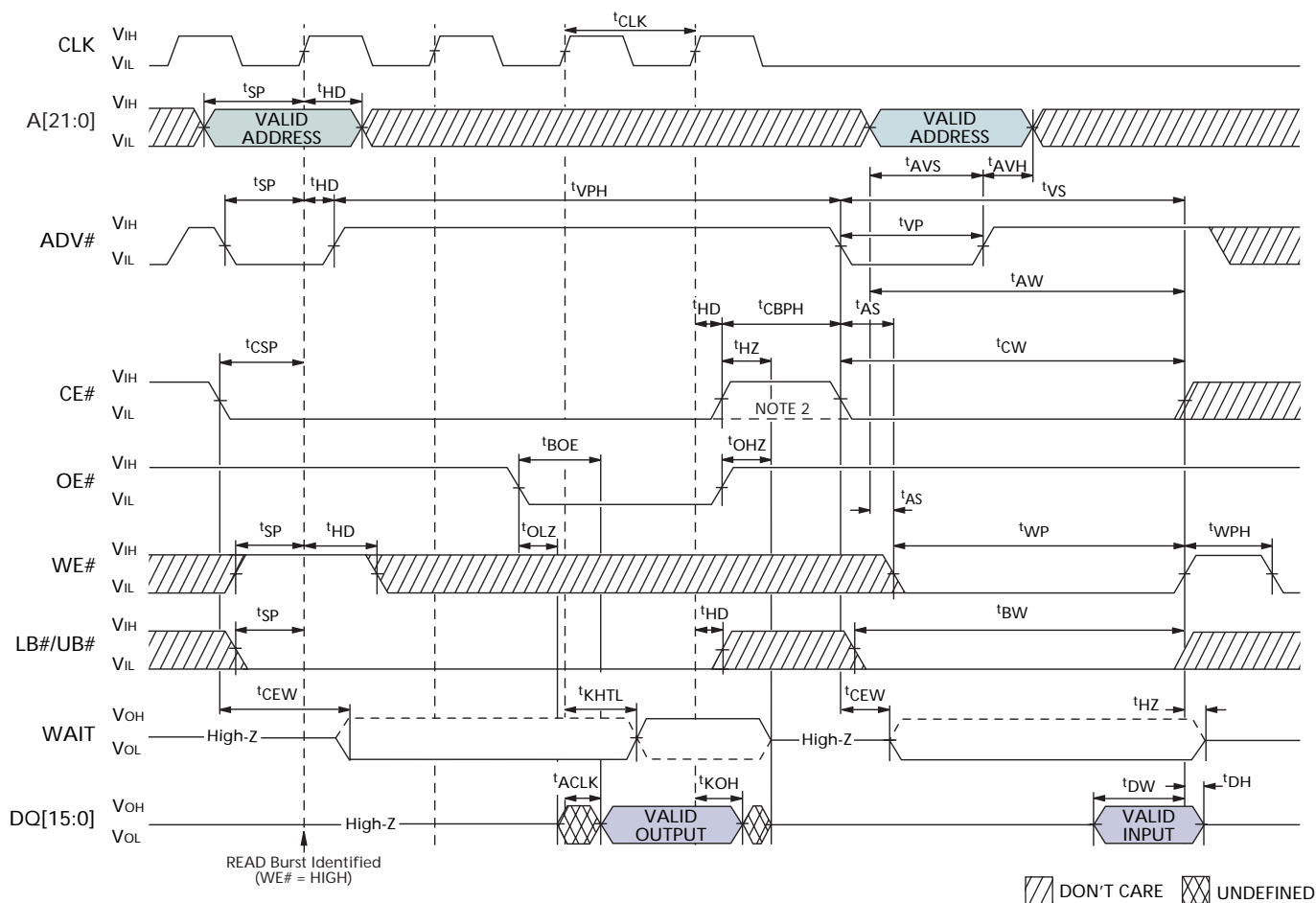

- Notes:
1. Non-default BCR settings for burst READ followed by asynchronous WRITE using ADV#: Fixed or variable latency; latency code two (three clocks); WAIT active LOW; WAIT asserted during delay.
 2. When transitioning between asynchronous and variable-latency burst operations, CE# must go HIGH. CE# can stay LOW when transitioning from fixed-latency burst READs. A refresh opportunity must be provided every t_{CEM} . A refresh opportunity is satisfied by either of the following two conditions: a) clocked CE# HIGH, or b) CE# HIGH for longer than 15ns.



64Mb: 4 Meg x 16 Async/Page/Burst CellularRAM 1.5 Memory Timing Diagrams

Figure 54: Asynchronous WRITE Followed by Asynchronous READ – ADV# LOW

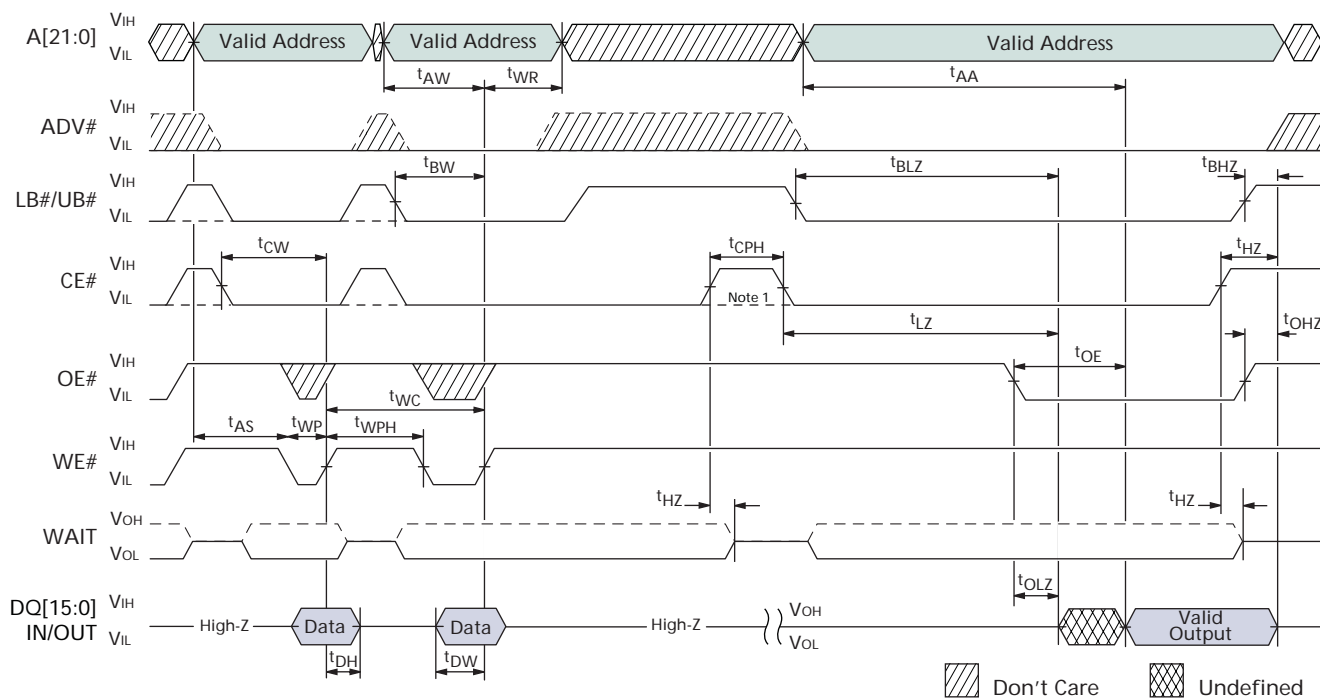

Notes: 1. When configured for synchronous mode (BCR[15] = 0), CE# must remain HIGH for at least 5ns (t_{CPH}) to schedule the appropriate refresh interval. Otherwise, t_{CPH} is only required after CE#-controlled WRITES.



64Mb: 4 Meg x 16 Async/Page/Burst CellularRAM 1.5 Memory Timing Diagrams

Figure 55: Asynchronous WRITE Followed by Asynchronous READ

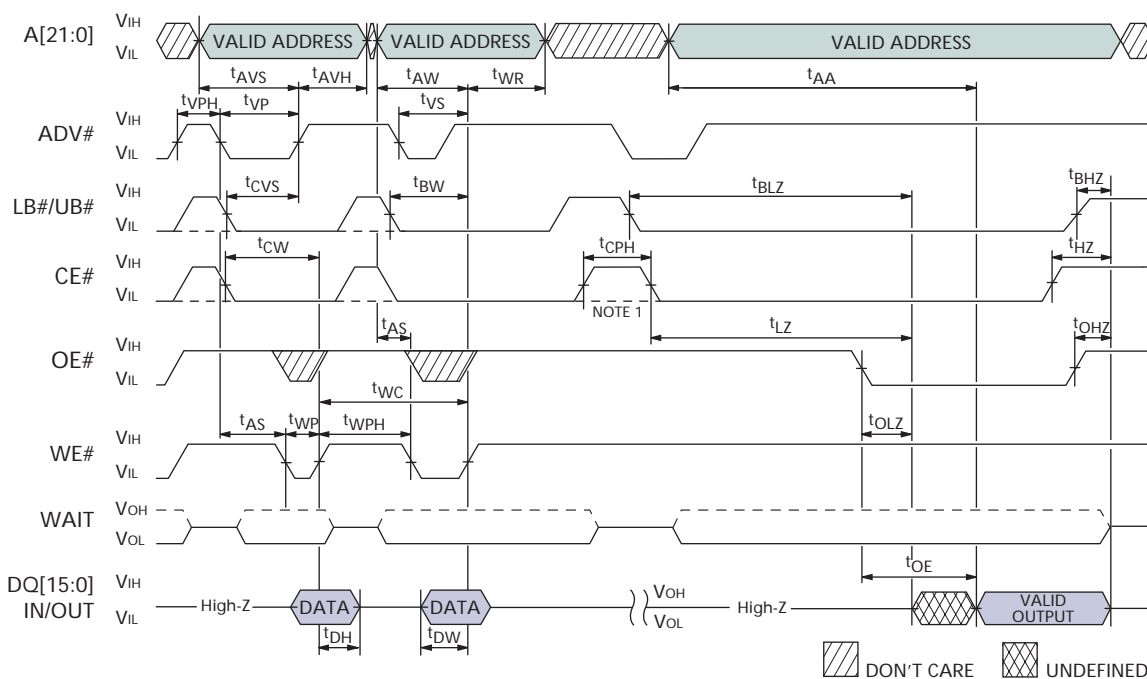

Notes: 1. When configured for synchronous mode (BCR[15] = 0), CE# must remain HIGH for at least 5ns (t_{CPH}) to schedule the appropriate refresh interval. Otherwise, t_{CPH} is only required after CE#-controlled WRITES.



64Mb: 4 Meg x 16 Async/Page/Burst CellularRAM 1.5 Memory Package Information

Package Information

Figure 56: 54-Ball VFBGA

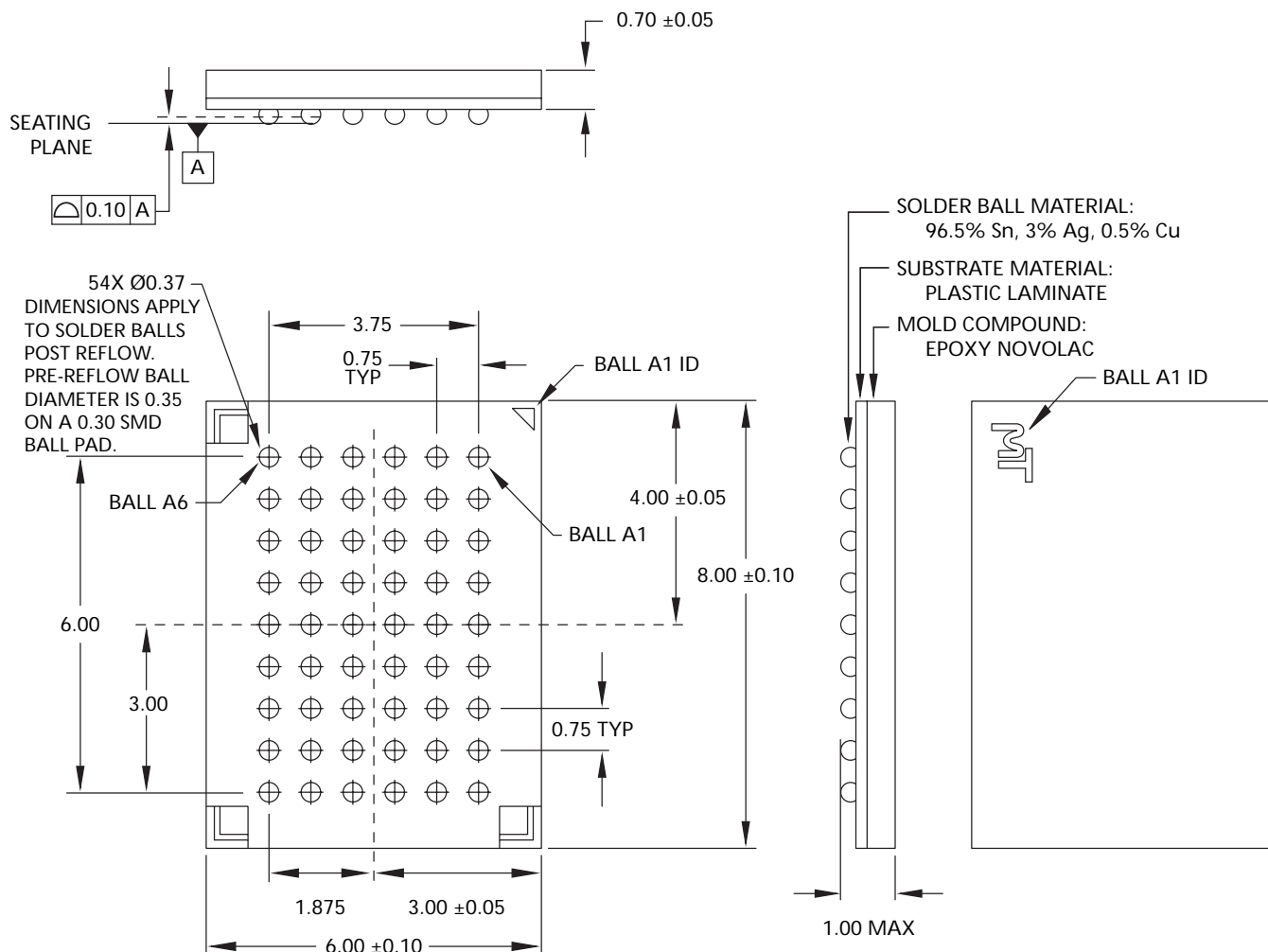

- Notes:
1. All dimensions in millimeters; MAX/MIN, or typical, as noted.
 2. Package width and length do not include mold protrusion; allowable mold protrusion is 0.25mm per side.
 3. The MT45W4MW16BKGB uses "green" packaging.



8000 S. Federal Way, P.O. Box 6, Boise, ID 83707-0006, Tel: 208-368-3900

prodmtkg@micron.com www.micron.com Customer Comment Line: 800-932-4992

Micron, the M logo, and the Micron logo are trademarks of Micron Technology, Inc. CellularRAM is a trademark of Micron Technology, Inc., inside the U.S. and a trademark of Infineon Technologies outside the U.S. All other trademarks are the property of their respective owners.

Advance: This data sheet contains initial descriptions of products still under development.



Revision History

Rev. A, Advance	11/06
• Initial Release	