

**HIGH VOLTAGE IGNITION COIL DRIVER
POWER IC**

TYPE	V _{CL}	I _c	I _d
VB024	400 V	8 A	100 mA

- PRIMARY COIL CURRENT INTERNALLY SET
- PRIMARY COIL VOLTAGE INTERNALLY SET
- AUTOMATIC SHUT-OFF AT MAX CURRENT
- LOGIC LEVEL COMPATIBLE INPUT
- DIGITAL SIGNAL FEEDBACK TO INDICATE A PREDETERMINED CURRENT LEVEL

DESCRIPTION

The VB024 is a high voltage integrated circuit made using SGS-THOMSON VIPower technology, with vertical current flow power darlington and logic level compatible driving circuit.

The device performs the following functions: power stage for driving the primary side of the ignition coil, digital signal feedback to the control IC to indicate a predetermined current level, automatic shut-off at maximum current, self clamping for voltage flyback and logic level input.

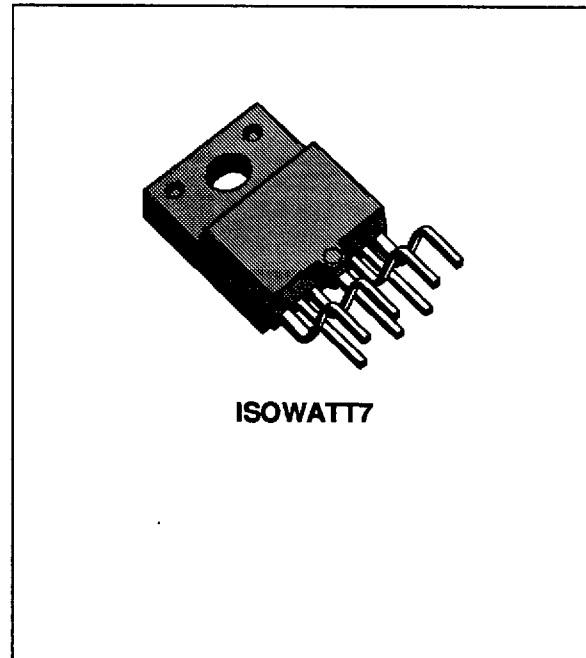

BLOCK DIAGRAM

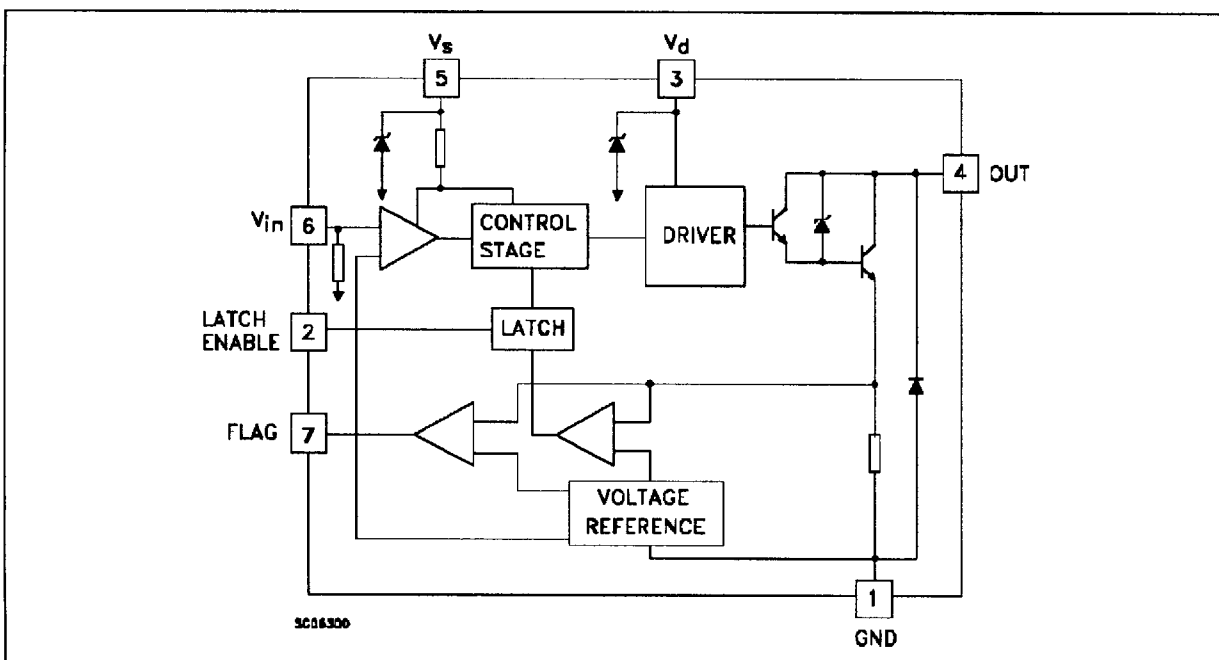

ABSOLUTE MAXIMUM RATING

Symbol	Parameter	Value	Unit
HV_C	Collector Voltage	Internally Limited	V
I_C	Collector Current	Internally Limited	A
V_d	Driving Stage Supply Voltage	16	V
I_d	Driving Circuitry Supply Current	600	mA
V_{in}	Maximum Input Voltage	10	V
V_s	Control Circuitry Supply Voltage	8	V
I_s	Control Circuitry Supply Current	200	mA
T_J	Operating Junction Temperature	-40 to 150	°C
T_{stg}	Storage Temperature Range	-55 to 150	°C

THERMAL DATA

$R_{thj-case}$	Thermal Resistance Junction Case (MAX)	2.5	°C/W
$R_{thj-amb}$	Thermal Resistance Junction Ambient (MAX)	30	°C/W

CONNECTION DIAGRAM

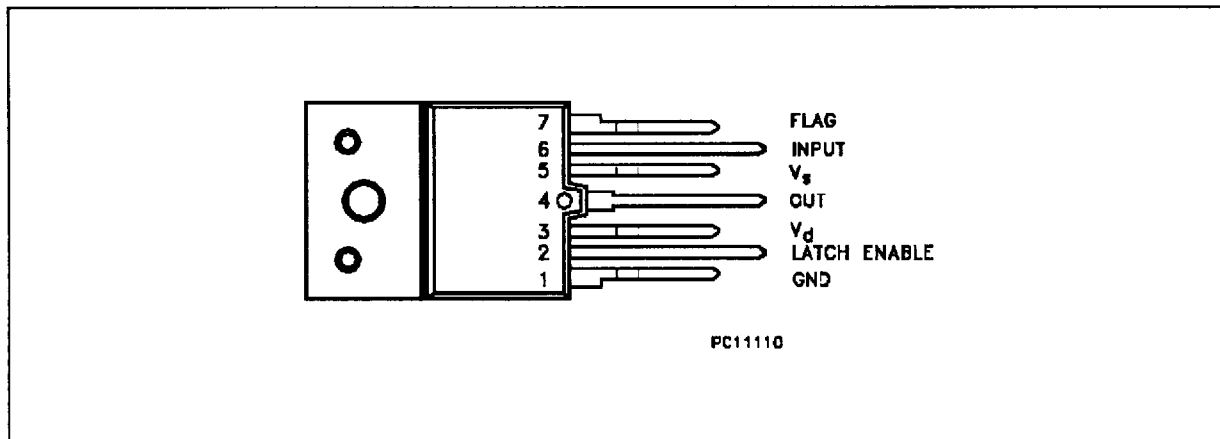

PIN FUNCTION

No	NAME	FUNCTION
1	GND	Emitter Power and Control Ground
2	LATCH ENABLE	Enables Of The Latch Circuitry Which Turn Off The Driver
3	V_d	Supply Voltage For The Power Stage
4	OUT	Output to The Primary Coil
5	V_s	Supply Voltage For The Control Stage
6	INPUT	
7	FLAG	Output of A Logic Signal When I_C Is Greater Than 3 A

ELECTRICAL CHARACTERISTICS ($V_b = 12\text{ V}$; $V_s = 5\text{ V}$ Regulated; $T_j = 25\text{ }^\circ\text{C}$; $R_{\text{coil}} = 500\text{ m}\Omega$;
 $L_{\text{coil}} = 6\text{ mH}$ unless otherwise specified)

Symbol	Parameter	Test Conditions	Min.	Typ.	Max.	Unit
V_{cl}	High Voltage Clamp	$V_{\text{in}} = 0.4\text{ V}$ $-40^\circ\text{C} \leq T_j \leq 125\text{ }^\circ\text{C}$	320		510	V
$V_{\text{ce(sat)}}$	Saturation Voltage of The Power Stage	$I_c = 6\text{ A}$; $I_d = 80\text{ mA}$; $V_{\text{in}} = 4\text{ V}$			2	V
$I_{\text{s(on)}}$	Control Circuit Supply Current				15	mA
V_s	Control Circuit Supply Voltage		4.5		5.5	V
$I_{\text{d(on)}}$	Driver Stage Stand-by Current	$V_{\text{in}} = 4\text{ V}$			180	mA
V_d	Driver Stage Supply Voltage		5.5		16	V
I_{diag}	Diagnostic Current at Wich The Flag Switches	$-40^\circ\text{C} \leq T_j \leq 125\text{ }^\circ\text{C}$	2.75		3.35	mA
V_{inH}	High Level Input Voltage		4		5.5	V
V_{inL}	Low Level Input Voltage		0		0.2	V
I_{inH}	High Level Input Current	$V_{\text{in}} = 5.5\text{ V}$	20		600	μA
V_{pos}	Positive Threshold		2.8		3.2	V
V_{neg}	Negative Threshold		1.3		1.7	V
V_{hys}	Hysteresis Voltage		1.3		1.7	V
$I_{\text{c(max)}}$	Turn-Off Current	$V_{\text{in}} = 4\text{ V}$ $-40^\circ\text{C} \leq T_j \leq 125\text{ }^\circ\text{C}$	7.3		8.8	A
t_{off}	Switch-Off Time	$I_c = 6\text{ A}$ (see note 1)	10		80	μs
V_{diagH}	High Level Diagnostic Output Voltage	$R_{\text{flag}} = 20\text{ K}\Omega$	4		4.5	V
V_{diagL}	Low Level Diagnostic Output Volatge	$R_{\text{flag}} = 100\text{ K}\Omega$			0.1	V

Note 1: Time from input switching V_{neg} until V_{CL} drops to 200 V

PRINCIPLE OF OPERATION

The VB024 is designed to drive the primary side of an ignition coil and provide a logic signal output to indicate a predetermined coil current level. This output signal is used to perform dwell control. This part is intended for use in Engine Control Modules. It could also be used in an ignition module or integrated into an ignition coil assembly.

The VB024 accepts an input High signal from the control IC to start charging the primary side of the ignition coil. When the primary coil current reaches 3 amps, the VB024 outputs a logic High signal to the control IC. This flag signal is used in the calculation of the dwell time.

This device also has a maximum primary coil current $I_{\text{c(max)}}$ Shut-off feature. $I_{\text{c(max)}}$ equals approximately 1.5 times the nominal primary coil current. If the I_c reaches $I_{\text{c(max)}}$, the output stage will Shut-off causing the spark to occur.

The VB024 is also internally clamped to protect it from the flyback voltage of the primary inductance as the output stage is turned off.

OVERVOLTAGE

The VB024 withstand the following transient test performed using a "Schaffner" equipment at $T_A = 80\text{ }^\circ\text{C}$:

1) LOAD DUMP

Ten pulses with 10 second intervals between each transient. The device withstand load dump while fully on, fully off and during the transition between states (see figures 3 and 4).

2) NEGATIVE TRANSIENTS

Ten negative transients with 10 second intervals between each transient (see figure 5).

3) REVERSE BATTERY

Inversion of battery voltage for a time = 60 sec (see figure 5).

FIGURE1: Application Circuit

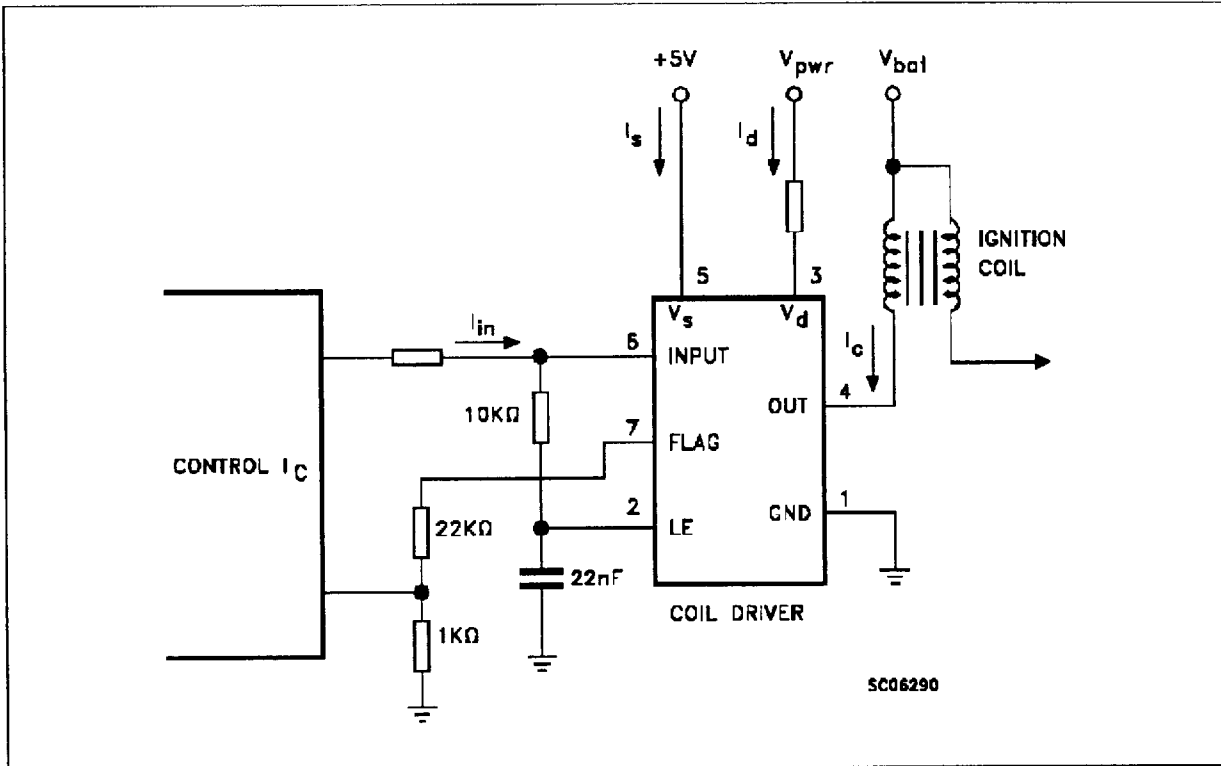

FIGURE2: Switching Waveforms

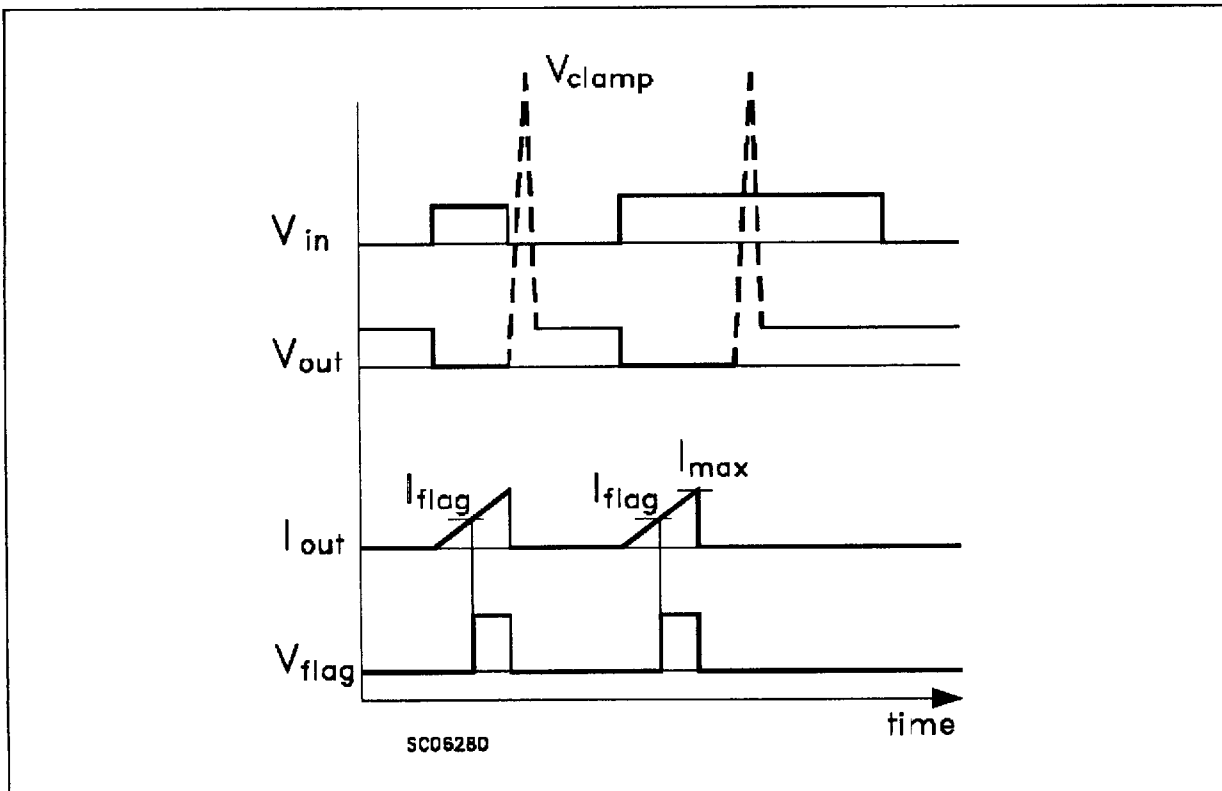

FIGURE 3: Load Dump Test Circuit

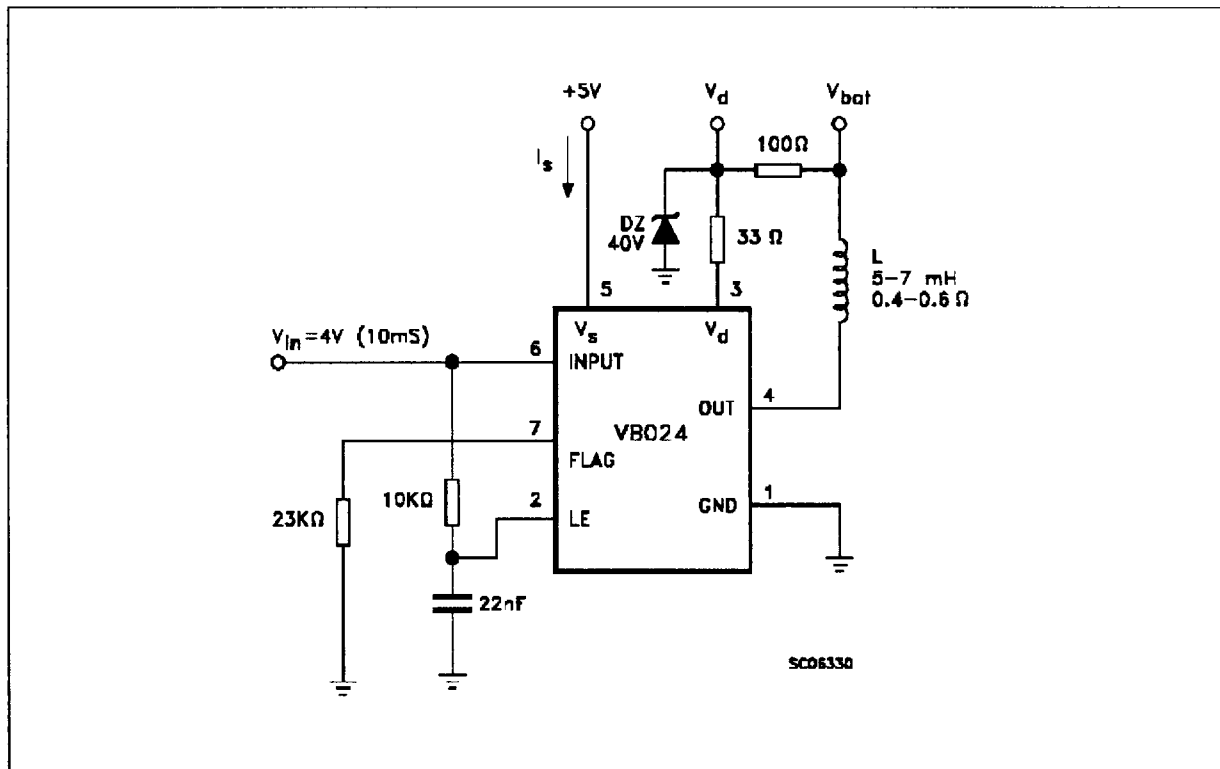

FIGURE 4: Load Dump Input Waveform

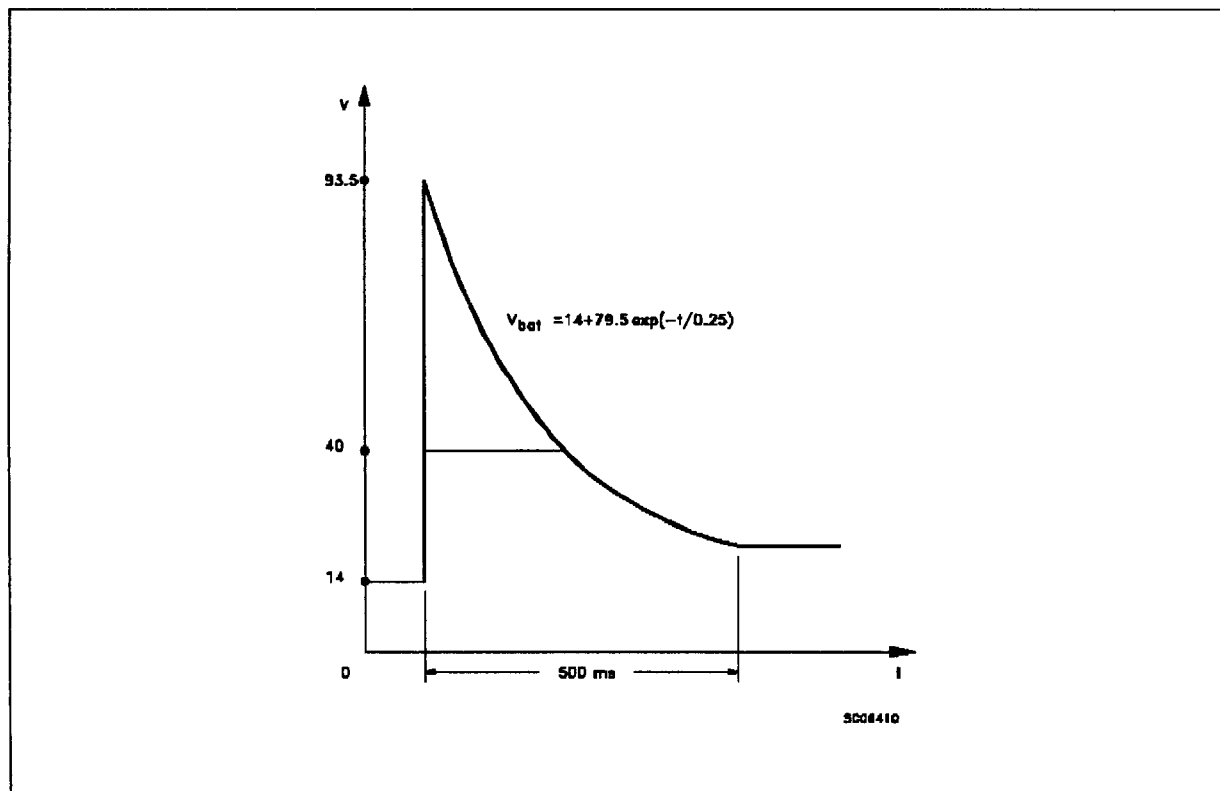

FIGURE 5: Negative Transients Test Circuit

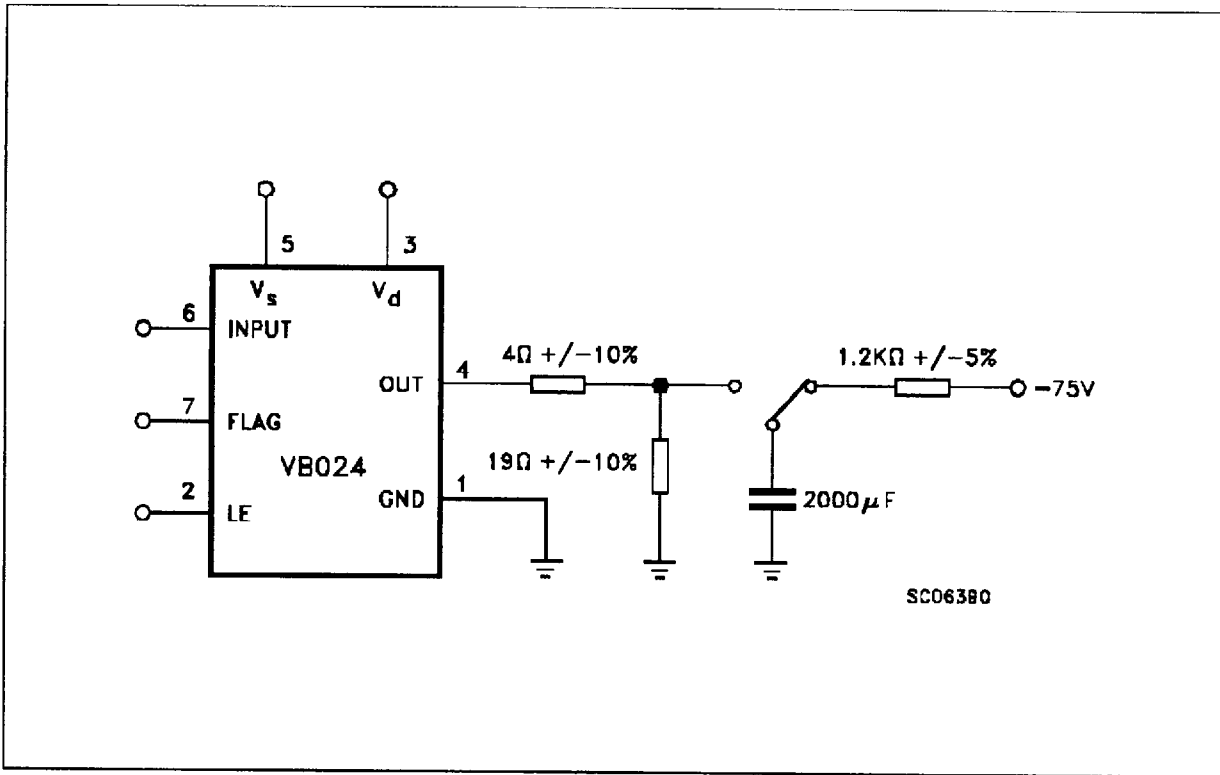
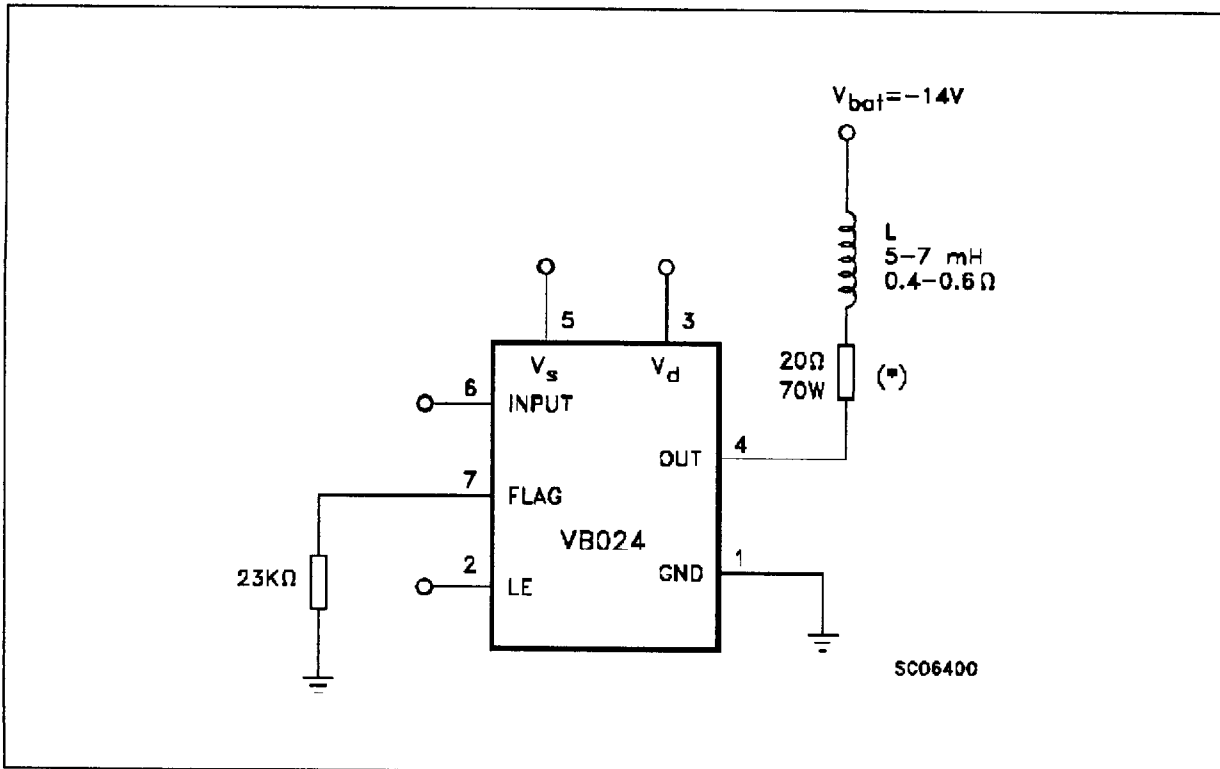

FIGURE 6: Reverse Battery Test Circuit



(*) This resistor represents vehicle wiring harness resistance

ISOWATT7 MECHANICAL DATA

DIM.	mm			Inch		
	MIN.	TYP.	MAX.	MIN.	TYP.	MAX.
A	5.35		5.65	0.210		0.222
B	3.4		3.7	0.133		0.145
C	0.8		1.28	0.031		0.050
D	2.95		3.1	0.116		0.122
D1	1.95		2.15	0.076		0.084
E	0.5		0.6	0.019		0.023
F		1.1			0.043	
F1	0.7		0.8	0.027		0.031
F2		1.4			0.055	
G	4.88		5.28	0.192		0.207
G1	7.42		7.82	0.292		0.308
G2	9.96		10.36	0.392		0.408
H	15.9		16.1	0.626		0.634
L1	19.85		20.15	0.781		0.793
L2	19.35		19.65	0.761		0.773
L3	8.9		9.1	0.350		0.358
L4	28		29	1.102		1.141
L5	4.9		5.1	0.193		0.201
L6	15.9		16.1	0.626		0.634
L7	2.1		2.3	0.082		0.090
L8	23		23.4	0.905		0.921
L9	24.8		25.2	0.976		0.992
L10	19.8		20.2	0.779		0.795
L11	17.7		18.3	0.697		0.720
M	7.83		8.33	0.308		0.328
N	2.75		3.25	0.108		0.128
∅	3.5		3.7	0.138		0.145

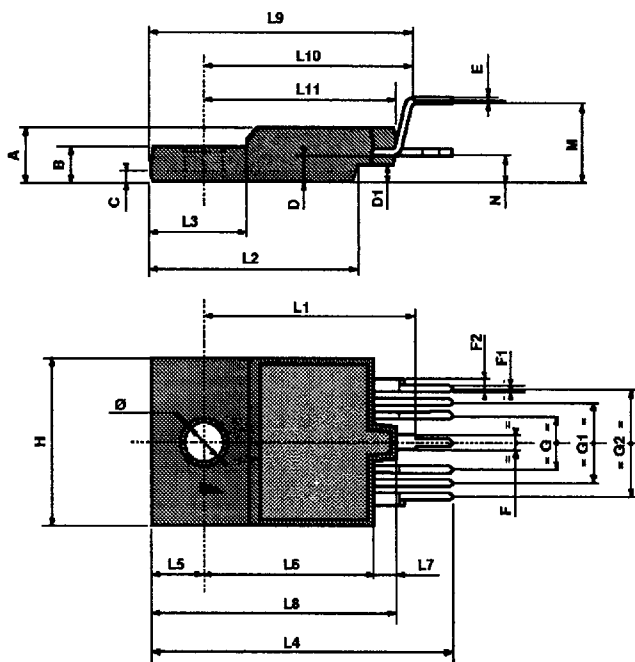

P033B

Information furnished is believed to be accurate and reliable. However, SGS-THOMSON Microelectronics assumes no responsibility for the consequences of use of such information nor for any infringement of patents or other rights of third parties which may result from its use. No license is granted by implication or otherwise under any patent or patent rights of SGS-THOMSON Microelectronics. Specifications mentioned in this publication are subject to change without notice. This publication supersedes and replaces all information previously supplied. SGS-THOMSON Microelectronics products are not authorized for use as critical components in life support devices or systems without express written approval of SGS-THOMSON Microelectronics.

© 1994 SGS-THOMSON Microelectronics - All Rights Reserved

SGS-THOMSON Microelectronics GROUP OF COMPANIES
Australia - Brazil - France - Germany - Hong Kong - Italy - Japan - Korea - Malaysia - Malta - Morocco - The Netherlands -
Singapore - Spain - Sweden - Switzerland - Taiwan - Thailand - United Kingdom - U.S.A