

Airpak

transmitter and receiver modules

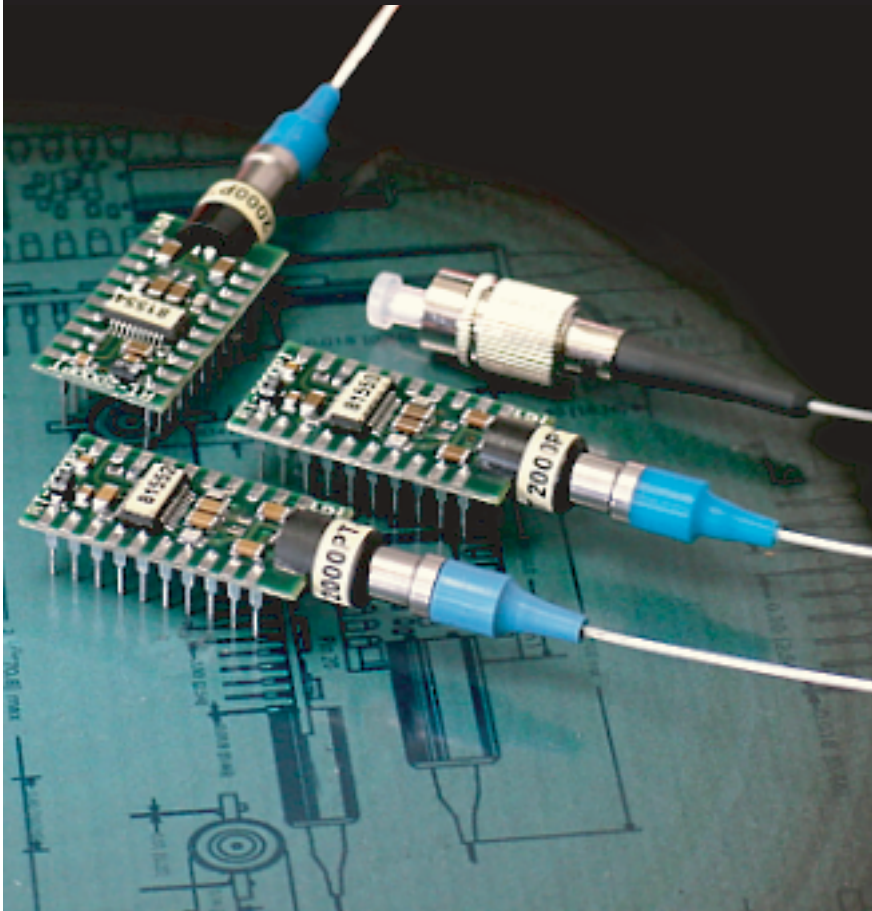

- SONET OC1, OC3 transmitters
- SONET OC1, OC3, OC12 receivers
- SDH STM-1 transmitters
- SDH STM-1, STM-4 receivers
- ATM/FDDI
- High-loss budget links
- Up to 622 Mb/s receivers
- Up to 155 Mb/s transmitters
- 1310nm and 1550nm
- PECL or ECL operation
- 20-Pin multisource pinout

The Airpak series laser transmitters and receivers are full function, high performance digital fiber optic modules. They provide a cost effective interface between standard ECL and PECL logic families and optical fiber transmission systems.

The innovative application of high-quality surface mount technology and a unique integration of optical and electrical components provide performance and quality without the traditional high cost packaging usually associated with optical modules. The superior reliability engineering on which the modules are based ensures performance in all normal environments and operating conditions.

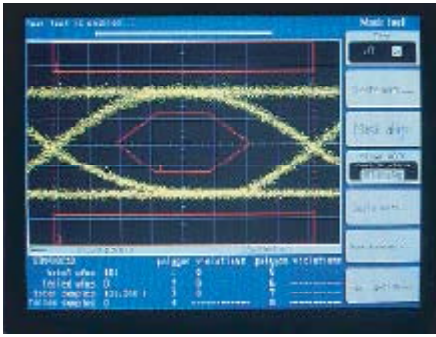

Testing an eye-opening mask to ensure CCITT/ANSI compliance.

Transmitters

Transmitter Functional Diagram

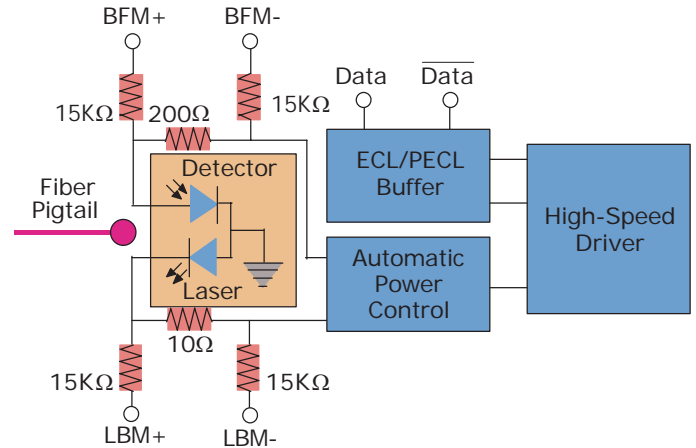

Recommended Transmitter Bias for PECL Applications

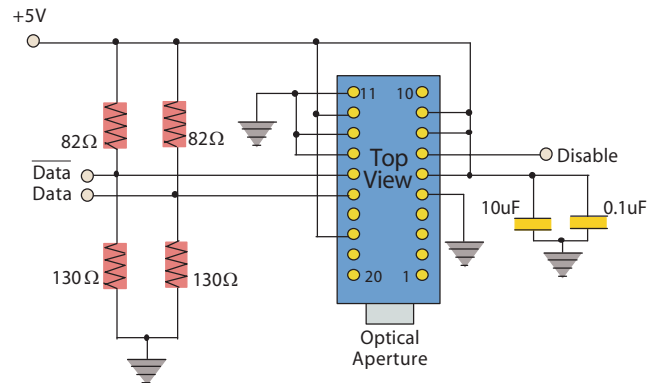

Recommended Transmitter Bias for ECL Applications

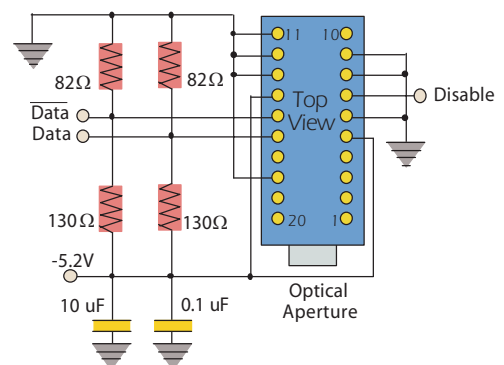

Airpak series laser transmitters are designed for applications up to 155 Mb/s including CCITT SDH and ANSI SONET standard data rates.

The modules feature single 5 volt supply operation and a logic interface compatible with either ECL or PECL. The optical source is a low threshold current, MQW Fabry-Perot laser coupled with a singlemode fiber. The fully self-contained module includes all bias and modulation control circuitry and a disable function to put the laser in standby mode. High- and low-power versions are available for short, intermediate, and long-haul applications. Analog voltage outputs proportional to the laser current and the optical power are available for system fault diagnosis. This compact transmitter complies with industry standard, 20-pin, dual-in-line footprint.

Functional Description

High-Speed Driver

The high-speed driver modulates the laser above threshold to maximize speed and minimize pulse-width distortion. The high-speed drive current is controlled by a temperature-sensing network that compensates for the reduction in a laser's power slope at higher operating temperatures by increasing the drive current. The result is that a minimum extinction ratio is maintained over all operating conditions.

Laser Status Section

The laser's back facet monitor network provides an external differential voltage proportional to the optical power emitted. This monitor is useful in determining whether the transmitter is functioning properly when locating faults along the fiber link.

...continued

- data rates up to 155 Mb/s**
- low threshold FP laser**
- wide operating temperature**
- 1310nm and 1550nm options**
- automatic power control**
- transmitter disable**
- optical power monitor**
- laser bias monitor**

Transmitter Configuration

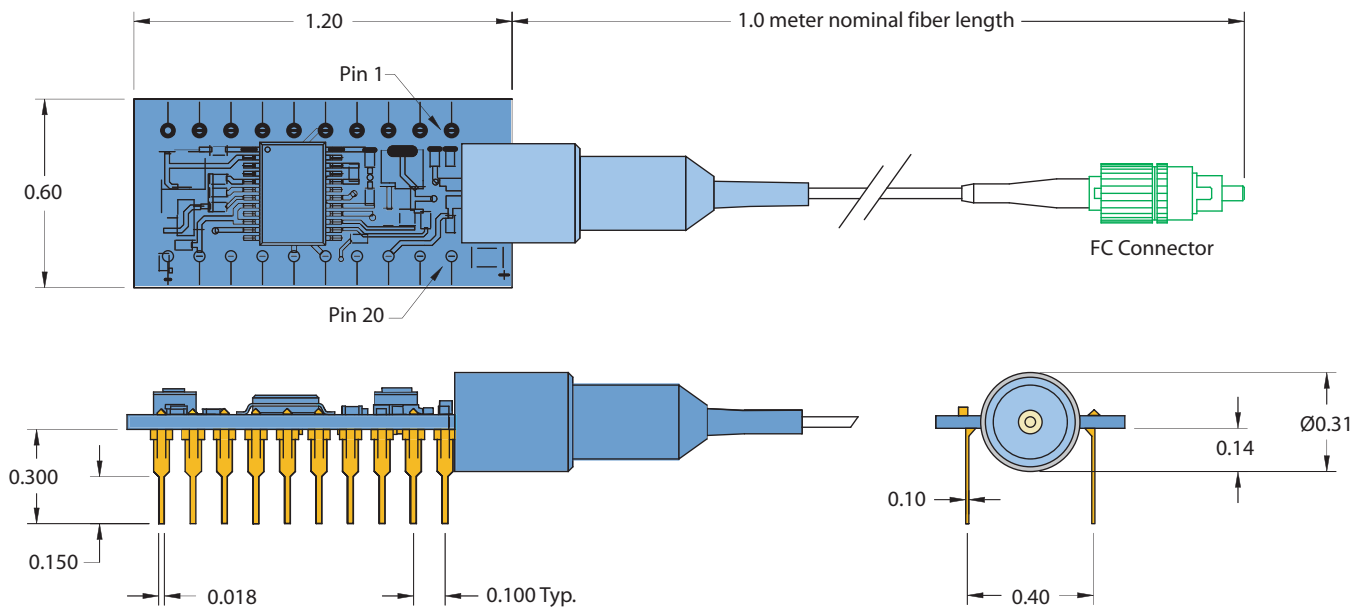

The laser's bias current is also monitored with a differential voltage via pins 2 and 4. A variation in this voltage is normal when operating the module at temperatures other than room temperature because the automatic control circuit will increase the bias to maintain constant optical power. Any connection to the monitor pins should be high-impedance.

Enable/Disable

The disable function turns off the optical output. This feature may be used in applications where the output power must be off, such as when the transmitter is in standby mode.

Automatic Power Control

The automatic power control section maintains constant average power over the operating temperature range. The control also compensates for normal increases in the laser's operating current due to normal long-term aging effects.

Design Considerations

Typical connections that the user can implement to interface with ECL and PECL logic are indicated herein. Good high-frequency design techniques should be used when laying out a PC board to ensure optimum signal quality. A ground plane is recommended with the bypass capacitors and terminating resistors located as close to the module as possible.

Application of Status Alarms

When implementing an external status alarm, a differential amplifier should be used to convert the differential monitor signal to a single-ended signal. This signal can then be fed to a simple comparator to detect a change in operating status. For example, the laser bias monitor can be used in conjunction with a differential amplifier and comparator to signal an increase in bias current of 50 percent or more at 25°C indicating a possible malfunction.

Pin	Function
1,3,10,20	No connection
2	Laser Bias Monitor +
4	Laser Bias Monitor -
5,14	V _{ee}
6,8,9,12,18	V _{cc}
7	Disable
11,13	Ground
15	Data
16	Data
17	Back Facet Monitor -
19	Back Facet Monitor +



Airpaks use high quality surface mount assembly.

Transmitter Specifications and Limits

Optical Characteristics (Performance @ 25°C)

	Units	Min	Typ	Max
Center wavelength	nm			
TL 2063		1290	-	1330
TL 2065		1520	-	1570
Average output power (over operating temperature range)	dBm			
TL 2063PT-010, TL 2065PT-010		-10	-8	-5
TL 2063PT-005, TL 2065PT-005		-5	-3	0
Spectral width (RMS)	nm	-	2.5	-
Extinction ratio	dB	10	12	-
T_X disable¹	V	-3.2	-	0

Electrical Characteristics (Performance @ 25°C)

	Units	Min	Typ	Max
Supply voltage ($V_{CC} - V_{EE}$)	V	4.75	5	5.5
Supply current	mA	-	70	130
Input data voltage¹	V			
Low		-	-1.8	-
High		-	-0.8	-
Bias Monitor	V	0.01	-	0.45
Back facet monitor	V	0.01	-	0.2

Absolute Maximum Ratings

	Units	Min	Typ	Max
Supply voltage	V	-	-	6
Storage temperature	°C	-40	-	85
Operating temperature²	°C	-40	-	85
Lead soldering temp/time	°C/sec	-	-	250/1

Notes:

¹ Measured from V_{CC} with a 50-ohm load to $V_{CC} - 2$ volts.

² Temperature range for 1310nm transmitters only.

Transmitter Ordering Information

Part Number	Data Rate (NRZ Mb/s)	Nominal Wavelength (nm)	Typical P _{AVG} (dBm)	Interface Type	Operating Temperature (°C)
TL 2063PT-010FC	155	1310	-8	9/125/900 um pigtail, FC/PC connector	-40 to +85
TL 2063PT-005FC	155	1310	-3	9/125/900 um pigtail, FC/PC connector	-40 to +85
TL 2065PT-010FC	155	1550	-8	9/125/900 um pigtail, FC/PC connector	-40 to +65
TL 2065PT-005FC	155	1550	-3	9/125/900 um pigtail, FC/PC connector	-40 to +65

Note:

FC/PC connectors on the fiber pigtail are standard.

Other connector types are available.

Receivers

The Airpak series receivers are high-performance, cost-effective optical modules optimized for use in SONET and SDH systems. The wide dynamic range transimpedance design accepts a maximum optical input power of 0 dBm with typical sensitivities of -40 dBm at 52 Mb/s, -38 dBm at 155 Mb/s, and -32 dBm at 622 Mb/s. A single +5 volt supply is required without the need for additional negative detector bias. However, to use the optical power-monitor function and to enhance sensitivity at 622 Mb/s, a negative voltage may be applied though Pin 10 of the module. Data outputs are differential PECL compatible. This compact receiver complies with an industry standard 20-pin, dual-in-line footprint and has a multimode fiber pigtail, making it compatible with both singlemode and multimode systems.

Functional Description

Optical Front-End

The optical front-end consists of an InGaAs photo-detector coupled to a wide dynamic range transimpedance amplifier for low noise and high bandwidth. An internal AGC circuit allows for input power up to 0 dBm.

Amplifier and Quantizer

The high gain amplifier stage limits large-amplitude signals to maintain wide dynamic range. The quantizer section provides PECL output levels to the data and flag outputs for 52 Mb/s and 155 Mb/s products. Data outputs are also PECL for the 622 Mb/s version, but the flags are TTL. This is compliant with the multisource standard.

Receiver Functional Diagram

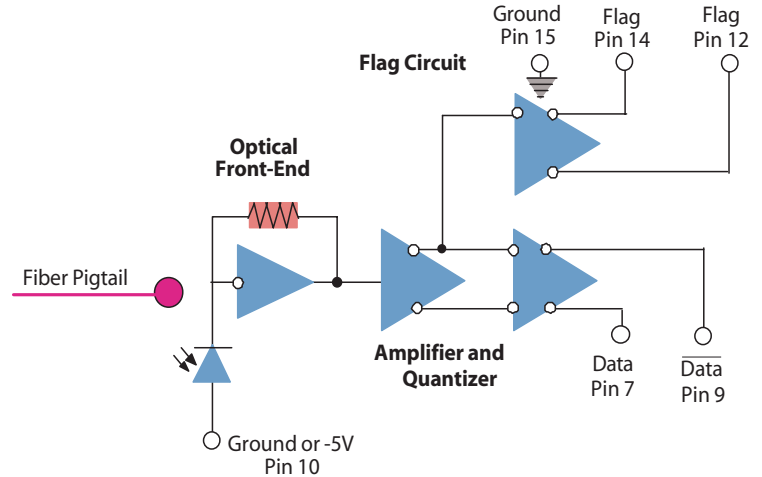

Recommended Receiver Bias for PECL Applications

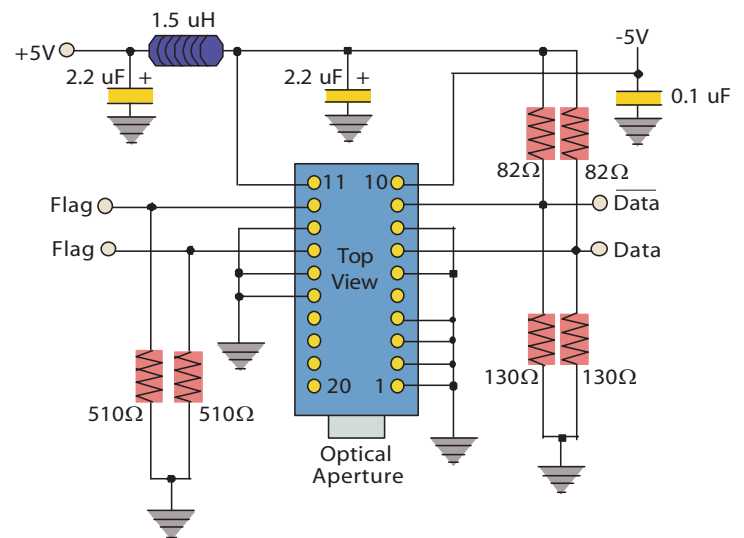

Recommended Receiver Bias for ECL Applications

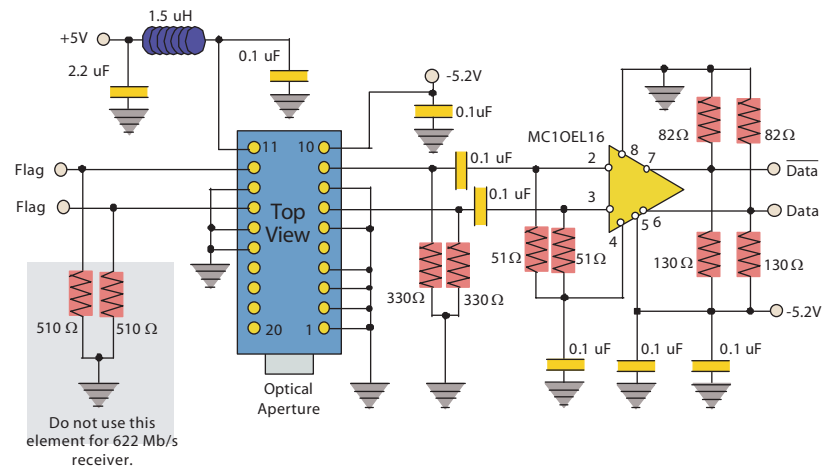

- data rates of 52, 155, 622 Mb/s**
- 1310nm and 1550nm operation**
- single 5-volt capable**
- high sensitivity**
- high overload power**
- wide dynamic range**
- differential data and flag outputs**

Do not use this element for 622 Mb/s receiver.

Pin Assignments	
Pin	Function
1,2,3,4,6	Ground
8,13,15,16	Ground
5,17,18,19,20	No connection
7	Data
9	Data
10	-5V
11	+5V
12	Flag (+)
14	Flag (-)

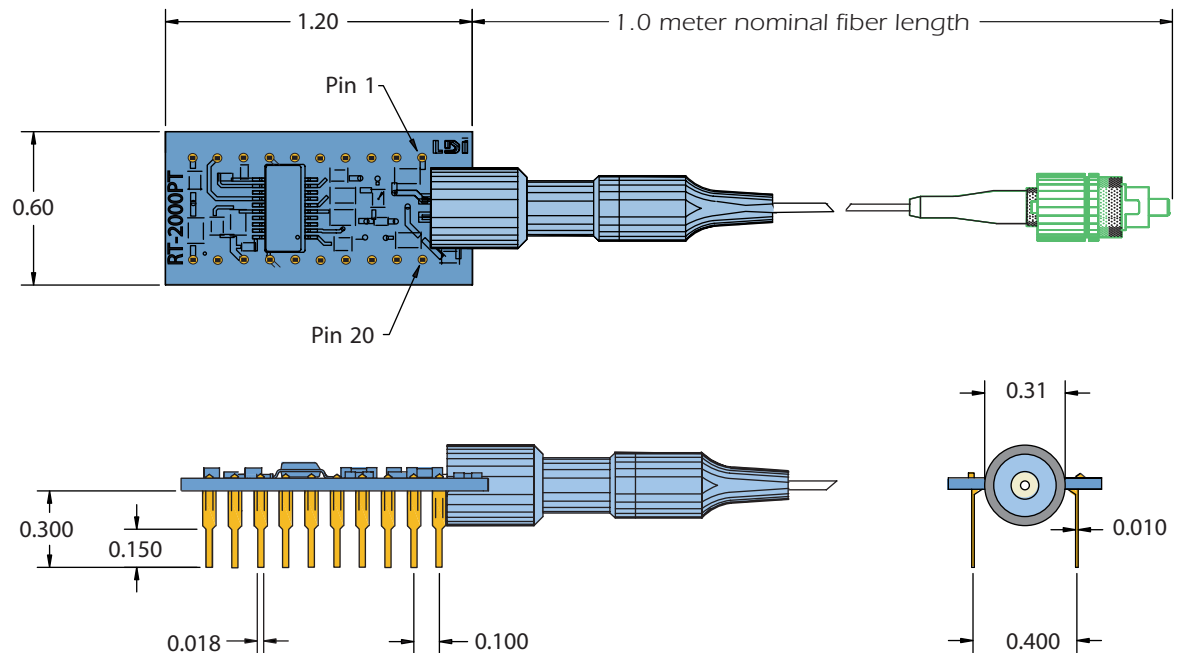

Data Outputs

Data outputs are differential PECL (Positive or Pseudo-ECL). The recommended terminations are shown herein. It is suggested that differential outputs be used for connecting to other logic families to eliminate possible noise margin problems, particularly at elevated temperatures. Data outputs must be terminated in equivalent loads for optimal performance.

Flag Outputs

The flag circuit differentiates between the presence or absence of the optical signal with a typical hysteresis of 1 dB. When an acceptable signal (see specification) is present, the flag output is logic-high.

Design Considerations

Typical connections the user can implement to interface with ECL and PECL logic are indicated in the accompanying schematics. Good high frequency design techniques should be used when laying out a PC board to ensure optimum signal quality. A ground plane is recommended with the bypass capacitors and terminating resistors located as close to the module as possible. Additional power supply filtering may be required if excessive noise is present due to nearby switching power supplies or other noise sources.

Data Outputs Power Supply

A +5 volt DC source is the only supply required. Pin 10 should be grounded if not used as a photodetector monitor. Pins 1, 2, 3, 4, and 16 may be left unconnected or may be grounded.

Photodetector Monitor

A photodetector monitor can be implemented for applications requiring access to a signal proportional to the input optical power. This option is utilized by connecting Pin 10 to the -5 volt supply through a series resistor. It is recommended that the resistor have a maximum 2.7 Kohm value if the maximum optical input capability of the receiver is going to be used. If the function is not used, Pin 10 may be grounded.

Termination of fibers with a choice of optical connectors.



Receiver Specifications and Limits

Optical Characteristics (Performance @ 25°C)

	Units	Min	Typ	Max
Measured average sensitivity¹	dBm			
52 Mb/s		-38	-40	-
155 Mb/s		-36	-38	-
622 Mb/s		-30	-32	-
Maximum input power	dBm	-3		-
Link status threshold	dBm			
(Flag-logic low, decreasing light input)				
52 Mb/s		-54	-	-38
155 Mb/s		-45	-	-36
622 Mb/s		-45	-	-28
Link status threshold	dBm			
(Flag-logic high, increasing light input)				
52 Mb/s		-55	-	-39
155 Mb/s		-44	-	-35
622 Mb/s		-44	-	-27

Electrical Characteristics (Performance @ 25°C)

	Units	Min	Typ	Max
Supply voltage (V_{CC})	V	4.8	5	5.3
Supply current	mA	-	100	150
Output data voltage²	V			
Low		-1.8	-1.75	-1.5
High		-1.1	-1.0	-
Output flag voltage²	V		-	
Low (52 Mb/s and 155 Mb/s)		-1.8	-1.75	-1.5
High (52 Mb/s and 155 Mb/s)		-1.1	-1.0	-
Low (622 Mb/s) ³		-	0.2	0.5
High (622 Mb/s) ³		3.0	4.0	-

Absolute Maximum Ratings

	Units	Min	Typ	Max
Supply voltage	V	4.75	-	5.5
Operating case temperature	°C	-40	-	85
Storage temperature	°C	-40	-	85
Lead soldering temp/time	°C/sec	-	-	250/10

Notes: ¹ All values are at 1310nm, measured with an optical input using a 2²³-1 pseudo random pattern with a 50% duty cycle for a BER of 10⁻¹⁰.

² Measured from V_{CC} with a 50-ohm load to V_{CC} -2 volts.

³ Measured from ground.

Receiver Ordering Information

Part Number	Data Rate (NRZ Mb/s)	Typical Sensitivity (dBm)	Interface Type	Operating Temperature (°C)
RT 2000PT-052FC	52	-40	50/125/900 um pigtail, FC/PC connector	-40 to +85
RT 2000PT-155FC	155	-38	50/125/900 um pigtail, FC/PC connector	-40 to +85
RT 2000PT-622FC	622	-32	50/125/900 um pigtail, FC/PC connector	-40 to +85

Note:

FC/PC connectors on the fiber pigtail are standard. Other connector types optional.

Airpak transmitter and receiver modules

Product Changes

Laser Diode Incorporated reserves the right to make changes to the product(s) or information contained herein without notice. No liability is assumed as a result of their use or application.

Personal Hazard (Transmitter only)

Normal aversion reactions will protect from radiation hazards to the eye associated with devices of this kind. Direct and prolonged exposure to a laser beam may cause eye damage. Observe precautions accompanying the product and precautions appropriate to a Class IIIb laser.

Handling Precautions

Handle optical fiber with normal care, avoiding stretch, tension, twist, kink, or bend abuse. Products are subject to the risk normally associated with sensitive electronic devices including static discharge, transients, and overload.

Special Orders

Some products are supplied with performance characteristics to meet unique customer requirements and differ from those indicated herein. Contact the Laser Diode Incorporated Sales Department or your local representative to discuss your individual requirements. For a complete listing of representatives, visit our website at www.laserdiode.com.

Ordering

Products can be ordered directly from Laser Diode Incorporated or its representatives. For a complete listing of representatives, visit our website at www.laserdiode.com. Refer to the following part numbers:

Transmitter Ordering Information

Part Number	Data Rate (NRZ Mb/s)	Nominal Wavelength (nm)	Typical P _{AVG} (dBm)	Interface Type	Operating Temperature (°C)
TL 2063PT-010FC	155	1310	-8	9/125/900 um pigtail, FC/PC connector	-40 to +85
TL 2063PT-005FC	155	1310	-3	9/125/900 um pigtail, FC/PC connector	-40 to +85
TL 2065PT-010FC	155	1550	-8	9/125/900 um pigtail, FC/PC connector	-40 to +65
TL 2065PT-005FC	155	1550	-3	9/125/900 um pigtail, FC/PC connector	-40 to +65

Receiver Ordering Information

Part Number	Data Rate (NRZ Mb/s)	Typical Sensitivity (dBm)	Interface Type	Operating Temperature (°C)
RT 2000PT-052FC	52	-40	50/125/900 um pigtail, FC/PC connector	-40 to +85
RT 2000PT-155FC	155	-38	50/125/900 um pigtail, FC/PC connector	-40 to +85
RT 2000PT-622FC	622	-32	50/125/900 um pigtail, FC/PC connector	-40 to +85

Note: FC/PC connectors on the fiber pigtail are standard. Other connector types are available. Contact the Laser Diode Incorporated Sales Department.



CAUTION: Use of controls, adjustments, or performance of procedures other than specified herein may result in hazardous radiation exposure.