

WS4683C

USB PD and Type-C Current-Limited Load Switch

[Http://www.sh-willsemi.com](http://www.sh-willsemi.com)

Descriptions

The WS4683C is a Type-C PD load switch with programable precision current limit. WS4683C has V_{IN} under voltage lockout, output over voltage protection, reverse current protection, over current protection and over temperature protection.

The over current protection threshold is set by an external resistor from ILIM pin, ranged from 400mA to 3.3A. The output current will be clamped at threshold if load current hit the current limit. WS4683C will assert /FLT pin to low with an 11ms deglitch time after over current protection triggers.

FO pin is used to program the power on slow rate for V_{BUS} , which will be 2ms soft start if FO is pulled to GND. Such function can be disabled by pulling FO pin to high. Fast RCP recovery circuit is also implemented, with the help of witch the switch will turn on within 20 μ s once it exits reverse condition.

WS4683C has a 2.05x2.05mm 16-bump WLCSP package. Standard product is Pb-Free and Halogen-Free.

Features

- V_{IN} ranged from 4.0V to 5.5V
- 30V VBUS tolerance
- All time reverse current protection
- Ultra-fast RCP recovery
- Programmable current limit from 400mA to 3.3A
- Output current is regulated at current limit for over load condition
- Output over voltage protection
- VBUS 8kV for IEC61000-4-2 contact discharge
- ESD Protection
 - HBM ANSI/ESDA/JEDEC JS-001 Class 2 exceed 2kV
 - CDM ESDA/JEDEC JS-002 exceed 500V

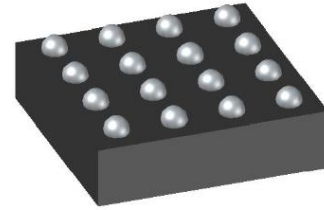

CSP-16L (Bottom View)

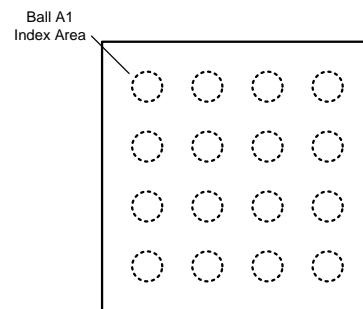

Pin Configuration (TOP View)

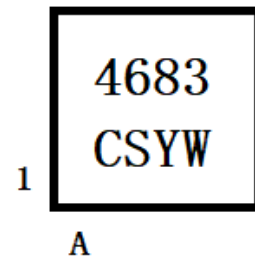

Marking

- 4683** = Device code
- CS** = Special code
- Y** = Year code
- W** = Week code

Order Information

Device	Package	Shipping
WS4683C-16/TR	CSP-16L	3000/Reel&Tape

Applications

- Laptop, ultra-book and desktop
- USB PD or Type-C port/hubs
- Tablet and smart phone

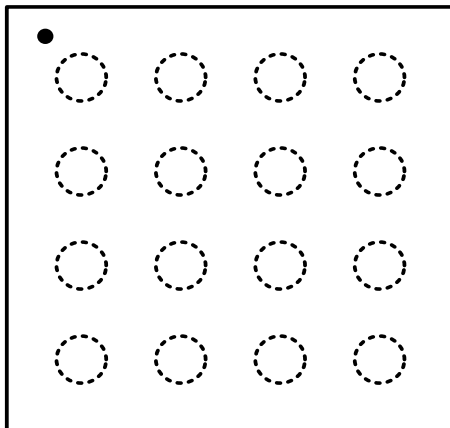
Pin Configuration (Top View)

	1	2	3	4
A	VIN	VIN	ILIM	/FLT
B	VCP	VCP	GND	EN
C	VCP	VBUS	GND	FO
D	VBUS	VBUS	GND	CAP

Pin Descriptions

Symbol	Pin	Descriptions
VIN	A1, A2	Input pin
VCP	B1, B2, C1	Common point of two power MOSFETs
VBUS	C2, D1, D2	Output voltage
ILIM	A3	Connect a resistor to GND to set the current limit value
/FLT	A4	Open drain output as a fault indicator
EN	B4	Enable pin
GND	B3, C3, D3	Ground pin
FO	C4	Pull this pin to HIGH to enable fast turn on feature
CAP	D4	Charge pump output cap

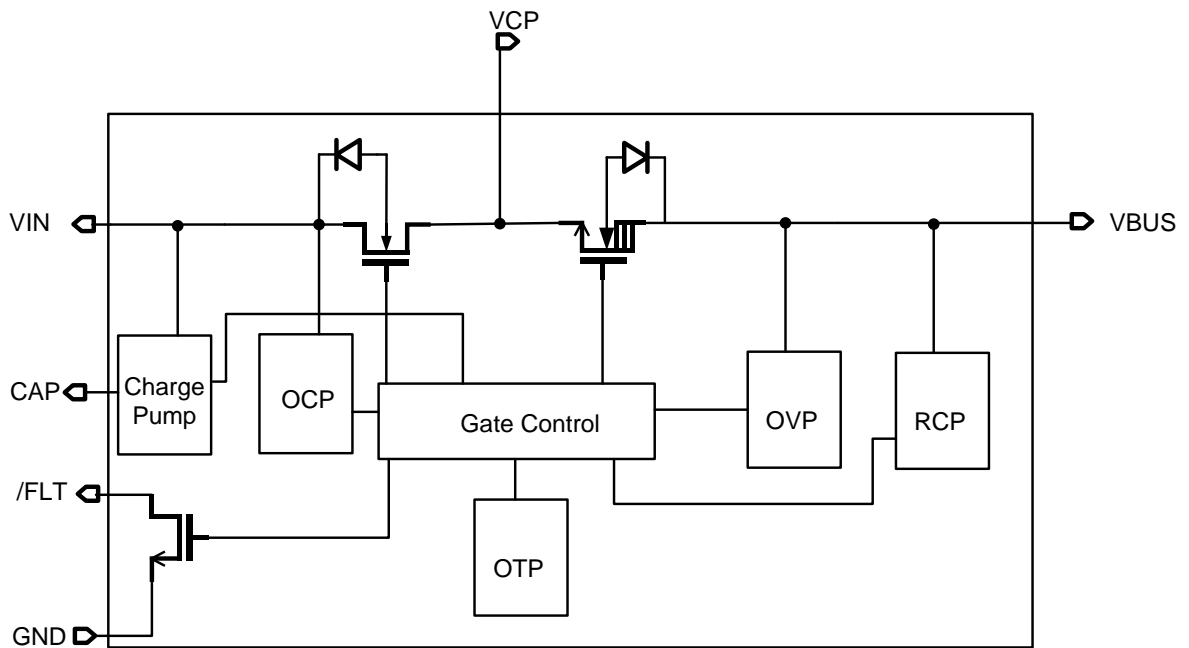
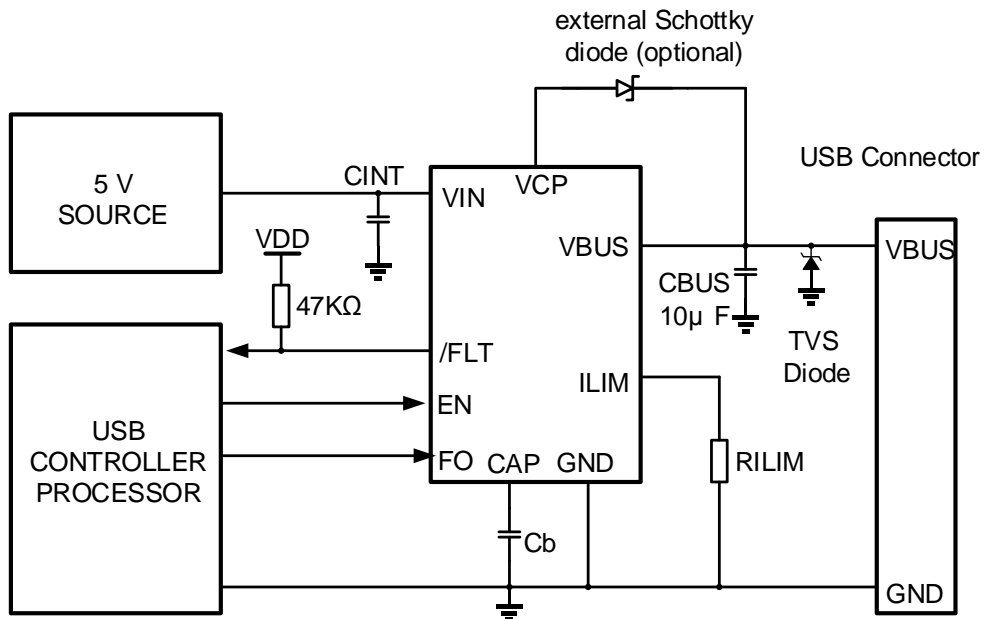
Functional Block Diagram

Application Block Diagram

Absolute Maximum Ratings ⁽¹⁾

Symbol	Parameter	Min.	Max.	Unit
V _{BUS}	VBUS	-0.5	30	V
V _{IO}	VIN, VCP, ILIM, EN, FO	-0.5	6.0	V
	CAP	-0.5	12	V
T _{stg}	Storage temperature	-65	150	°C
T _{JMAX}	Junction temperature	-40	150	°C
T _{lead}	Lead temperature	-	260	°C
I _{SW}	Power switch continuous current	-	3.6	A
ESD	IEC61000-4-2 (contact discharge)	8	-	kV

Recommend Operating Ratings ⁽²⁾

Symbol	Parameter	Min.	Typ.	Max.	Unit
V _{IN}	Power supply of VIN	4.0	5	5.5	V
V _{IO}	VCP, ILIM, EN, FO	0		5.5	V
	VBUS	0		23	V
T _J	Junction temperature	-40		125	°C
T _A	Ambient temperature	-40		85	°C

Note:

1. "Absolute Maximum Ratings" may cause permanent damage to the device. This is a stress only rating and operation of the device at these or any other conditions beyond those indicated in the operational sections of this specification is not implied.
2. The Recommended Operating Conditions table defines the conditions for actual device operation. Recommended operating conditions are specified to ensure optimal performance. WillSemi does not recommend exceeding them or designing to Absolute Maximum Ratings.

Electronics Characteristics (Ta=25 °C, V_{IN}=5V, unless otherwise noted)

Symbol	Parameter	Test Conditions	Min.	Typ.	Max.	Unit
V _{IH}	High level input voltage	V _{EN} =V _{FO} =V _{IN} =4V to 5.5V	1.2			V
V _{IL}	Low level input voltage	V _{EN} =V _{FO} =V _{IN} =4V to 5.5V			0.4	V
I _{VIN}	Supply current	VBUS pin open, V _{IN} =5V				
		V _{EN} =0V		1.5	3	μA
		V _{EN} =V _{IN} , R _{ILIM} =33kΩ		1.1	1.35	mA
		V _{EN} =V _{IN} , R _{ILIM} =16kΩ		1.35	1.65	mA
I _{S_OFF}	VBUS off leakage	V _{IN} =0V, V _{BUS} =5V, V _{EN} =0V	-5	0.1		μA
	VIN off leakage	V _{IN} =0V, V _{BUS} =20V, V _{EN} =0V	-2	0.1		μA
		V _{IN} =5V, V _{BUS} =0V, V _{EN} =0V	-2	0.1		μA
I _{S_ON}	Leakage at reverse condition	V _{IN} =5V, V _{BUS} =20V, V _{EN} =5V	-2	0.1		μA
R _{PD}	Pull-down resistance	V _{EN} =V _{FO} =V _{IN} =5V		1		MΩ
V _{UVLO}	-Under voltage lock out		3.6	3.76	3.9	V
V _{HYS_UVLO}	UVLO hysteresis			400		mV
V _{OL}	Output LOW voltage	/FLT pin, I _O =-4mA			0.3	V
V _{VBUS_OVP_R}	Output OVP rising threshold	V _{EN} =V _{IN} =5V		5.86		V
V _{VBUS_OVP_F}	Output OVP falling threshold	V _{EN} =V _{IN} =5V		5.7		V
T _{TSD}	Thermal shut down threshold	V _{IN} =4V to 5.5V		150		°C
T _{HYS_TSD}	Thermal shut down hysteresis	V _{IN} =4V to 5.5V		25		°C
R _{ON}	On resistance	V _{IN} =4V to 5.5V		35	49	mΩ
I _{OCP}	Over current protection	V _{IN} =4V to 5.5V, T _{AMB} =-40°C to 85°C				
		R _{ILIM} =100 kΩ	480	550	625	mA
		R _{ILIM} =54 kΩ	915	1013	1107	mA
		R _{ILIM} =24.5kΩ	2024	2220	2398	mA
		R _{ILIM} =33 kΩ	1505	1650	1780	mA
		R _{ILIM} =16 kΩ	3100	3300	3531	mA
		ILIM pin shorts to VIN pin	168	210	273	mA
T _{TLH}	LOW to HIGH output transition time	V _{BUS} =V _{IN} =5V, C _L =10μF, R _L =100Ω				
		V _{FO} =0V		2		ms
		V _{FO} =5V		50	100	μs
T _{EN}	Enable time	From EN pin to VOUT pin, V _{IN} =5V, C _L =10μF, R _L =100 Ω				
		V _{FO} =0V		0.75		ms
		V _{FO} =5V		60		μs
T _{DIS}	Disable time			70		μs
T _{ON_RCP}	RCP recovery time	V _{IN} =5V, V _{EN} =HIGH, C _L =10μF		12	20	μs
T _{Deglitch}	Deglitch time	V _{IN} =5V, OCP flag to /FLT pin output deglitch time	8	11	14	ms

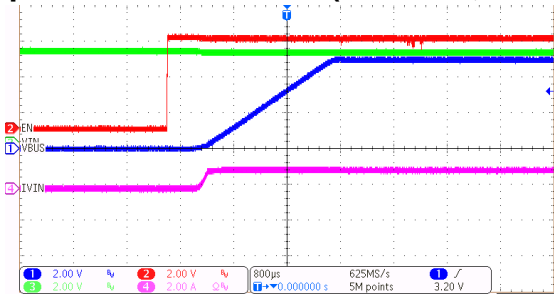
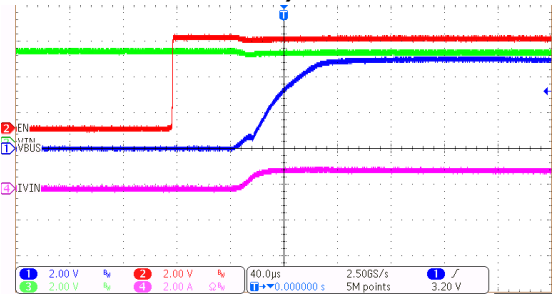
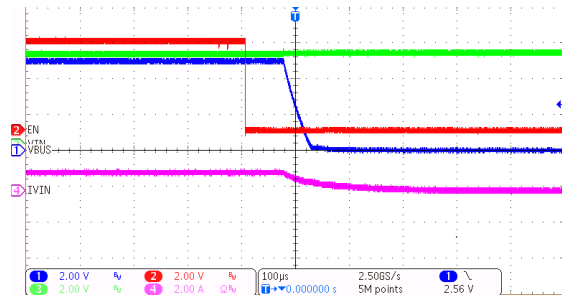
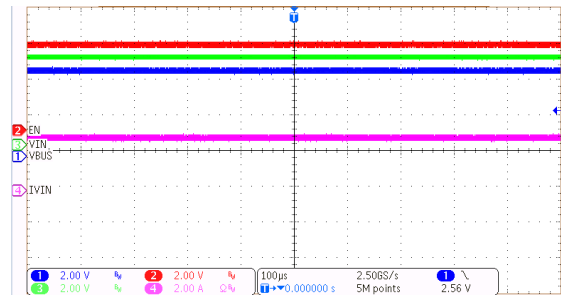
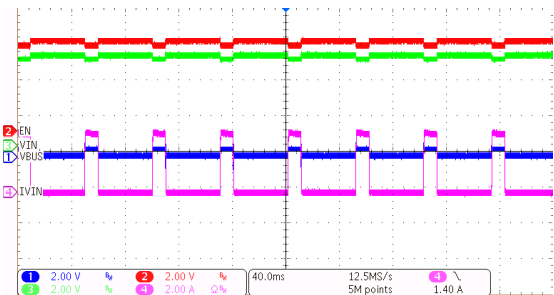
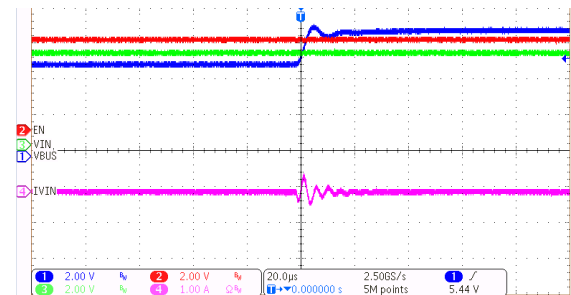
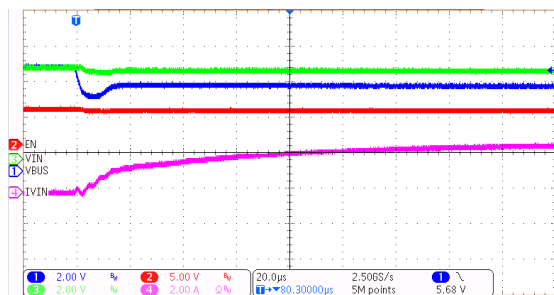
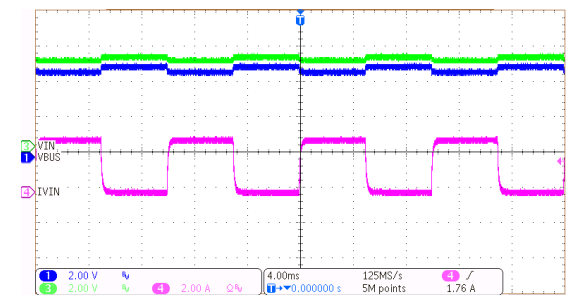
Typical Characteristics (Ta=25 °C, VIN=5V, unless otherwise noted)

EN Start-up with $V_{FO}=0V$ and 1A Load Current

EN Start-up with $V_{FO}=5V$ and 1A Load Current

Shut-down with 1A Load Current

Steady State with 3.3A Current Limit

Steady State with VBUS Pin Short-to-GND

 V_{BUS} Reverse Response

 V_{BUS} Reverse Recover Response

0A to 3A (2.5A/us) Load Transient

Detailed Description

Under-Voltage Lock-out (UVLO)

When V_{IN} is lower than the UVLO threshold, WS4683C will enter low power mode, which will disable the switch between VIN and VBUS. V_{IN} need to be higher than the threshold to turn on the switch.

EN Control

When EN pin is set to LOW, WS4683C will enter low power mode and disable the switch between VIN and VBUS. When EN pin is set to HIGH, the switch between VIN and VBUS is on if there is no other fault condition. There is a 1M Ω internal pull-down resistor to set EN pin default LOW.

Fast Turn-on

The WS4683C can limit the inrush current when powering-up V_{BUS} , and this is achieved by set FO pin to be LOW. Once V_{FO} is LOW, there will be a 2ms soft-start time for VBUS to power-up. For Fast Role Swap (FRS) application, fast turn on is needed. It is achieved by set FO pin to HIGH, and the rising time will be reduced to be as short as 100 μ s

Reverse Current Protection (RCP)

WS4683C will regulate the voltage drop from VIN to VBUS to be 70mv if load current is not too high and over current is not triggered. This is achieved by controlling the R_{ON} of the switch between VIN and VBUS dynamically. The regulation drop voltage can be reduced while the load current is small. If VBUS voltage is higher than VIN, the switch between VIN and VBUS will be turned off. During the RCP state, if V_{BUS} drops below V_{IN} , WS4683C will exit RCP state automatically and turn on the switch between VIN and VBUS within 20 μ s. The fast RCP recover function requires at least 1nF capacitor at CAP pin. WS4683C can also protect itself and the devices behind VIN when ultra-fast reverse event happens on VBUS pin.

Over Current Protection (OCP)

External resistor is used to set the current limit threshold for WS4683C. If ILIM pin is short to GND, the switch between VIN and VBUS will be disabled and /FLT pin asserts low. Once the load current at the VBUS triggers the over current threshold set by ILIM pin, WS4683C will regulate the current from getting higher. VBUS voltage may drop if load current is trying to getting larger. /FLT pin will assert low after 11ms deglitch time if over current state is still there.

Over Temperature Protection (OTP)

WS4683C monitors the silicon temperature once it is enabled and V_{IN} is higher than the UVLO threshold. It will disable the switch once silicon temperature is higher than 150 $^{\circ}$ C, and will enable the switch again if silicon temperature drops back to be lower than 125 $^{\circ}$ C. /FLT pin will assert low when over temperature triggers.

VBUS Over Voltage Protection (OVP)

WS4683C monitors voltage from VBUS. It will turn off the switch when V_{BUS} is higher than 5.86V and will turn on the switch again after V_{BUS} falls below 5.75V

/FLT Pin

/FLT pin is an open-drain output pin. /FLT pin sets LOW to indicate fault conditions including over current, over temperature and ILIM pin short-to-GND happening. If /FLT pin asserting LOW comes from over current, there will be an 11ms deglitch time, while there is no deglitch time for other cases.

PCB Layout Guide

For best performance, all traces must be as short as possible. To be most effective, the input and output capacitors must be placed close to the device to minimize the effects that parasitic trace inductances may have on normal operation. Using wide traces for VIN, VOUT, VCP, and GND helps minimize the parasitic electrical effects along with minimizing the case to ambient thermal impedance.

- 1) A 0.1uF ceramic capacitor CINT (C1A /C1B) is required for local decoupling. Higher capacitor values CINT (C1A /C1B) further reduce the voltage drop at the VIN pin. When driving inductive loads, a larger capacitance CINT (C1A /C1B) prevents voltage spikes from exceeding absolute. The CBUS (C2) capacitor should be placed as close as possible to VBUS pin.
- 2) The recommended Cb (C3) is 1nF with at least 16V voltage tolerance.
- 3) The external Schottky diode is not necessary. WS4683C works well without it.
- 4) A TVS diode should be added on VBUS node to protect surge event, such as hot plug-in.

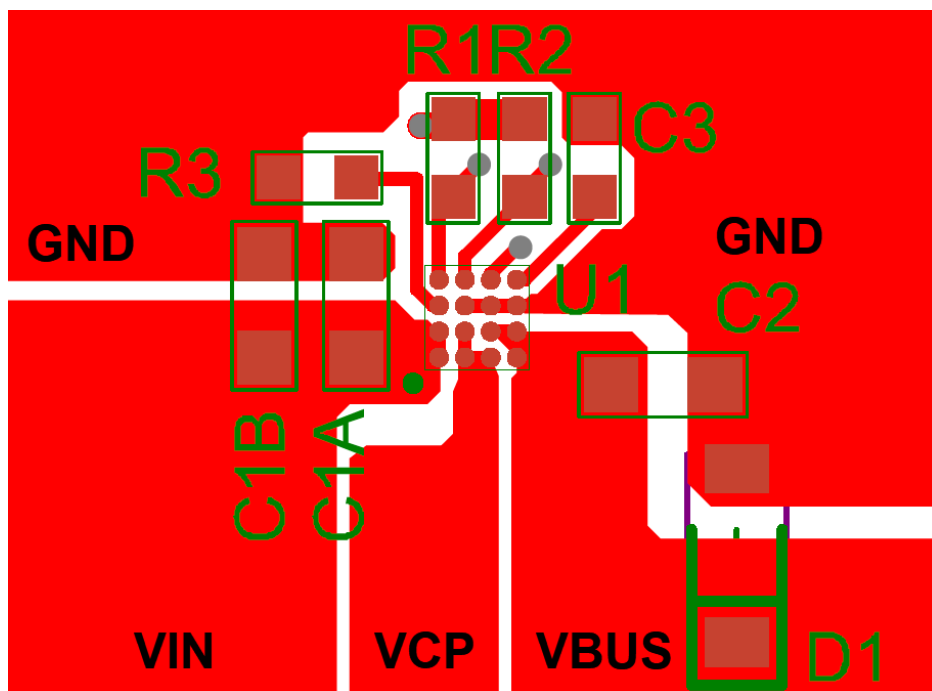

Layout Example (Top of PCB Board)

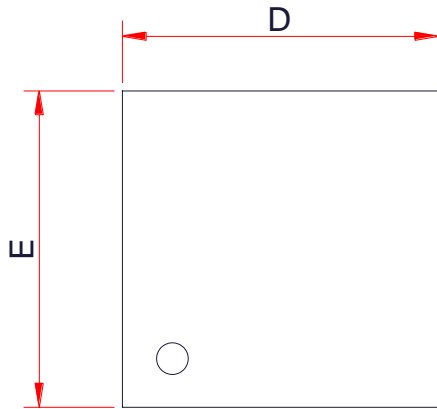
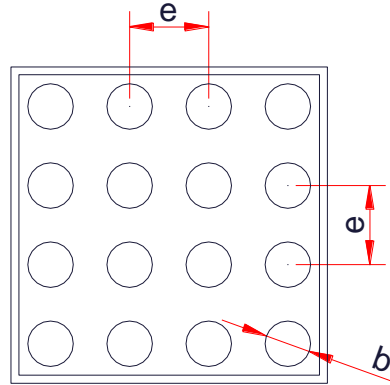
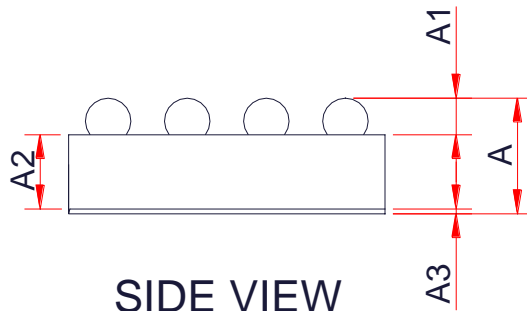
Package Outline Dimensions
CSP-16L

TOP VIEW

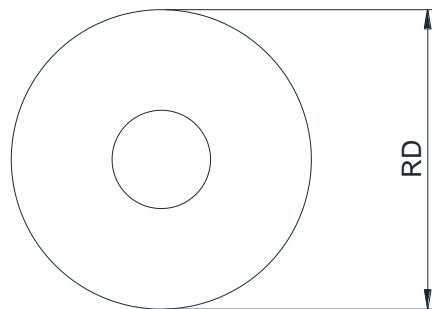
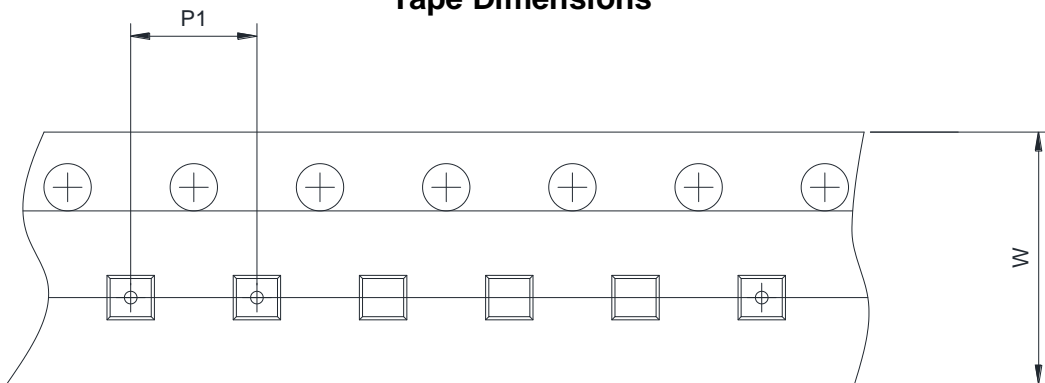
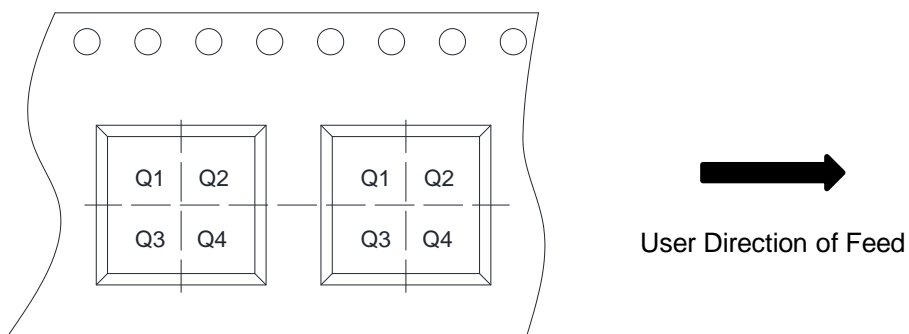
BOTTOM VIEW

SIDE VIEW

Symbol	Dimensions in Millimeters		
	Min.	Typ.	Max.
A	0.58	0.62	0.65
A1	0.22	0.24	0.26
A2	0.33	0.35	0.37
A3	0.03Ref		
D	2.02	2.05	2.08
E	2.02	2.05	2.08
b	0.30	0.32	0.34
e	0.50BSC		

Tape and Reel Information
Reel Dimensions

Tape Dimensions

Quadrant Assignments for PIN1 Orientation in Tape

RD	Reel Dimension	<input checked="" type="checkbox"/> 7inch	<input type="checkbox"/> 13inch		
W	Overall width of the carrier tape	<input checked="" type="checkbox"/> 8mm	<input type="checkbox"/> 12mm		
P1	Pitch between successive cavity centers	<input type="checkbox"/> 2mm	<input checked="" type="checkbox"/> 4mm	<input type="checkbox"/> 8mm	
Pin1	Pin1 Quadrant	<input checked="" type="checkbox"/> Q1	<input type="checkbox"/> Q2	<input type="checkbox"/> Q3	<input type="checkbox"/> Q4