

Radial Type TACT Switch(TM) > SKPL Series > SKPLAGD010

Series Common Info

## 6.45mm Diameter Low Contact Resistance Type with Round Terminal (Radial) SKPL Series

| Dimensions | Mounting Hole Dimensions | Circuit Diagram | Packing Specifications |  
 | Soldering Conditions |

PRINT

Part number		<b>SKPLAGD010</b>
Type	Radial	
Operating force	1.57N	
Operating direction	Top push	
Travel	1.3mm	
Operating life (5mA 5V DC)	100,000 cycles	
Initial contact resistance	100mΩ max.	
Rubber color	Gray	
Series type	Soft feeling type	
Operating temperature range	-40°C to +90°C	
Rating (max.)	50mA 16V DC	
Rating (min.)	10μA 1V DC	
Electrical performance	Insulation resistance	100MΩ min. 100V DC for 1min.
	Voltage proof	250V AC for 1 min.
Durability	Vibration	10 to 55 to 10Hz/min., the amplitude is 1.5mm for all the frequencies, in the 3 direction of X, Y and Z for 2 hours respectively
Environmental performance	Cold	-40±2°C for 1000h
	Dry heat	90±2°C for 1000h
	Damp heat	60±2°C, 90 to 95%RH for 1000h
Minimum order unit (pcs.)	Japan	2,700
	Export	2,700





## Dimensions

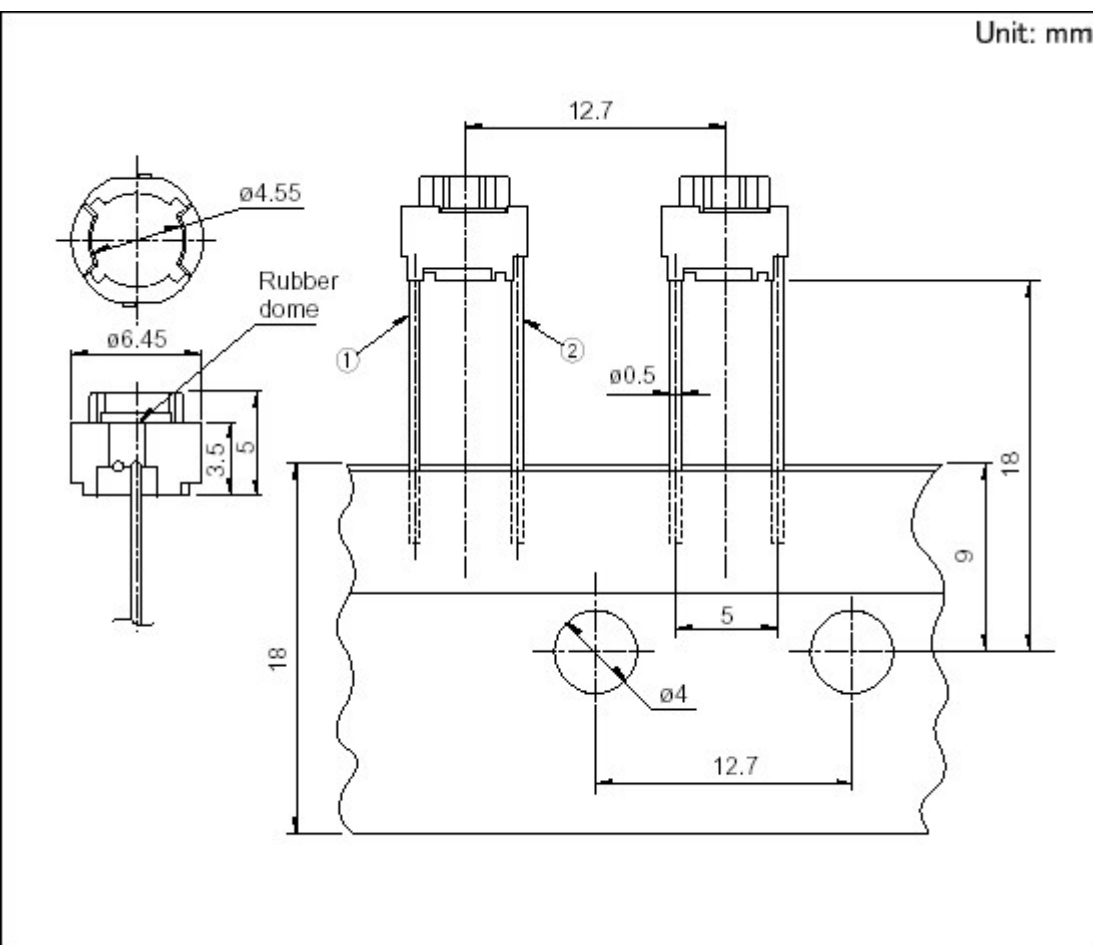

## Mounting Hole Dimensions

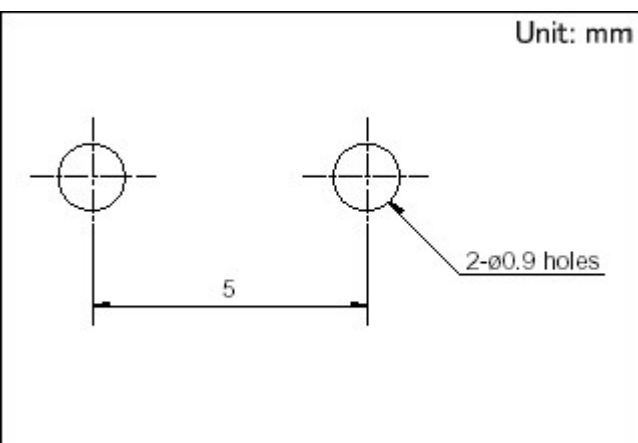

Viewed from mounting face.

## Circuit Diagram

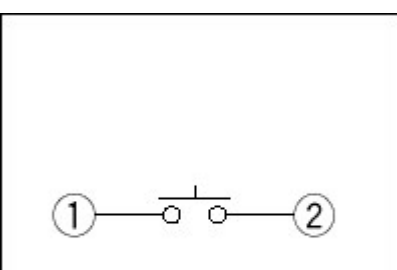

## Packing Specifications

### Taping

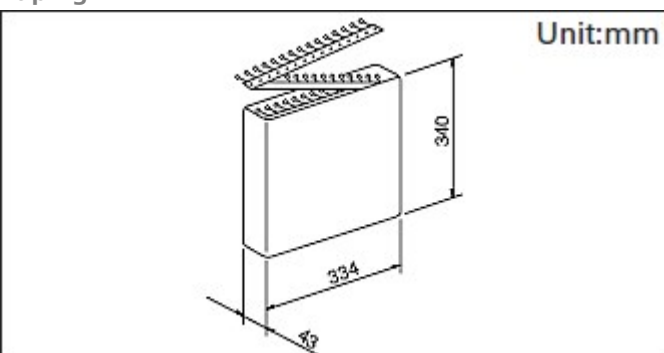

Number of packages (pcs.)	1 box	2,700
	1 case / Japan	27,000
	1 case / export packing	27,000
Export package measurements (mm)	353×716×244	

## Soldering Conditions

### Conditions for Auto-dip

Items	Condition
Flux built-up	Mounting surface should not be exposed to flux
Preheating temperature	Ambient temperature of the soldered surface of PC board. 100°C max.
Preheating time	60s max.
Soldering temperature	260°C max.
Duration of immersion	5s max.
Number of soldering	2 times max.

### Manual Soldering

Items	Condition
Soldering temperature	350°C max.
Duration of soldering	3s max.
Capacity of soldering iron	60W max.

1. Consult with us for availability of TACT switch™ washing.
  2. Prevent flux penetration from the top side of the TACT switch™.
  3. Switch terminals and a PC board should not be coated with flux prior to soldering.
  4. The second soldering should be done after the switch returns to normal temperature.
  5. Use the flux with a specific gravity of at least 0.81.  
(EC-19s-8 by TAMURA Corporation, or their equivalents.)
- 

## Notes are common to this series/models.

1. This site catalog shows only outline specifications. When using the products, please obtain formal specifications for supply.
2. Please use 1.6mm thick PC boards.
3. Please place purchase orders for taping products per minimum order unit (1 box or a case).
4. This products can be used in vehicles.  
Although these products are designed to perform over a wide operating temperature range, please ensure that you receive and read the formal delivery specifications before use.

## Inquiries about Products

 [Inquiry](#)