



# Complete, +5V-Powered, Isolated, Dual RS-232 Transceiver Module

**MAX252**

## General Description

The MAX252 complete, electrically isolated, dual RS-232 transmitter/receiver system requires no external components. By combining many functions in one package, the cost and complexity of an isolated digital interface are greatly reduced.

A single +5V supply powers both sides of the interface Transceivers, optocouplers, and a transformer in one low cost package provide a complete interface up to 9600 bits/sec. Additional pins provide low-power shutdown and a high-impedance state for both transmitter outputs.

The MAX252A withstands 130V<sub>RMS</sub> (continuous), 1260V<sub>RMS</sub> (1 min.) or 1520V<sub>RMS</sub> (1 sec.) and is intended for applications where very high transient voltages, differential ground potentials or noise may be encountered. The MAX252A is UL recognized. The MAX252B is intended for less stringent applications and is rated for 500V<sub>RMS</sub> (1 min.) or 600V<sub>RMS</sub> (1 sec.)

Receivers and line drivers (transmitters) meet EIA RS-232D and CCITT V.28 specifications. The MAX252 is supplied in 40-pin plastic DIP packages in commercial (0°C to +70°C) and extended (-40°C to +85°C) temperature ranges.

## Features

- ◆ Isolated Data Interface
- ◆ No External Components
- ◆ Single +5V Supply
- ◆ 50µW Low-Power Shutdown
- ◆ Two Transmitters and Two Receivers
- ◆ UL Recognized (MAX252A) - File E118032 to UL1577

## Ordering Information

PART	TEMP. RANGE	PIN-PACKAGE
MAX252ACH	0°C to +70°C	40 Plastic Module
MAX252BCH	0°C to +70°C	40 Plastic Module
MAX252AHL	-40°C to +85°C	40 Plastic Module
MAX252BEHL	-40°C to +85°C	40 Plastic Module

## Applications

- High-Noise Environments
- Automatic Test Equipment
- Differential Ground Potentials

## Typical Application

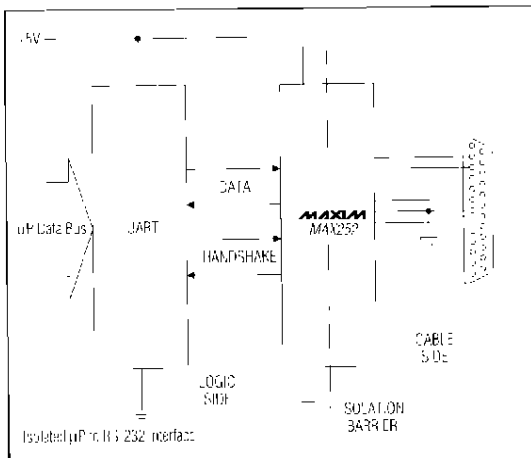

## Pin Configuration

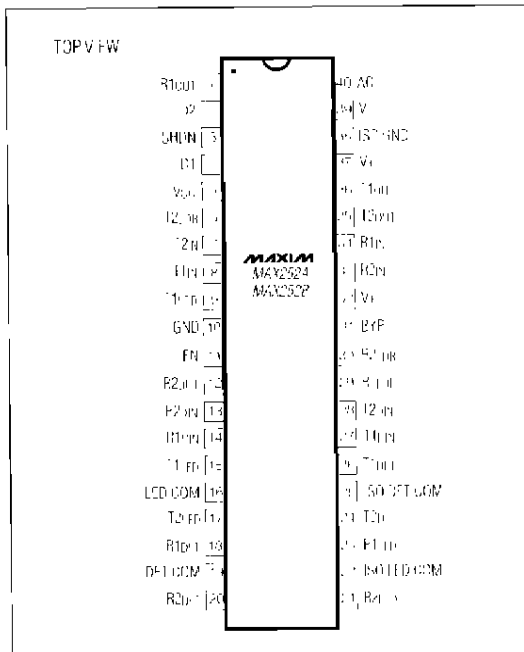

Call toll free 1-800-998-8800 for free samples or literature.



# Complete, +5V-Powered, Isolated, Dual RS-232 Transceiver Module

**MAX252**

## ELECTRICAL CHARACTERISTICS (continued)

(V<sub>CC</sub> = +5V ±10%, T<sub>A</sub> = T<sub>MIN</sub> to T<sub>MAX</sub>, unless otherwise noted.)

PARAMETER	SYMBOL	CONDITIONS	MIN	TYP	MAX	UNITS
<b>RS-232 CHARACTERISTICS</b>						
RS-232 Output Voltage Swing	V <sub>PP</sub>	T1 <sub>OUT</sub> , T2 <sub>OUT</sub> R <sub>L</sub> = 3kΩ to ISO	±5	±7.2		V
RS-232 Output Leakage Current		V <sub>+</sub> = V <sub>-</sub> = 0V or SHDN = V <sub>CC</sub> , T1 <sub>OUT</sub> , T2 <sub>OUT</sub> ±15V	-100		+100	μA
RS-232 Input Threshold High		R1 <sub>IN</sub> , R2 <sub>IN</sub>		1.8	3.0	V
RS-232 Input Threshold Low		R1 <sub>IN</sub> , R2 <sub>IN</sub>	0.6	1.2		V
RS-232 Input Hysteresis		R1 <sub>IN</sub> , R2 <sub>IN</sub>		0.6		V
RS-232 Input Resistance		R1 <sub>IN</sub> , R2 <sub>IN</sub> , T <sub>A</sub> = +25°C	3		7	kΩ
Transmitter Output Slew Rate	SR	R <sub>L</sub> = 3kΩ, C <sub>L</sub> = 2500pF Same as Tested Measured from +3V to -3V or -3V to +3V		3	30	V/μs
Propagation Delay	t <sub>p</sub>	RS-232 to TTL		24		μs
	t <sub>r</sub>	TTL to RS-232		20		
Transmission Rate		Sample Tested R <sub>L</sub> = 3kΩ C <sub>L</sub> = 2500pF	9600	19200		Bts/sec

## Typical Operating Circuit

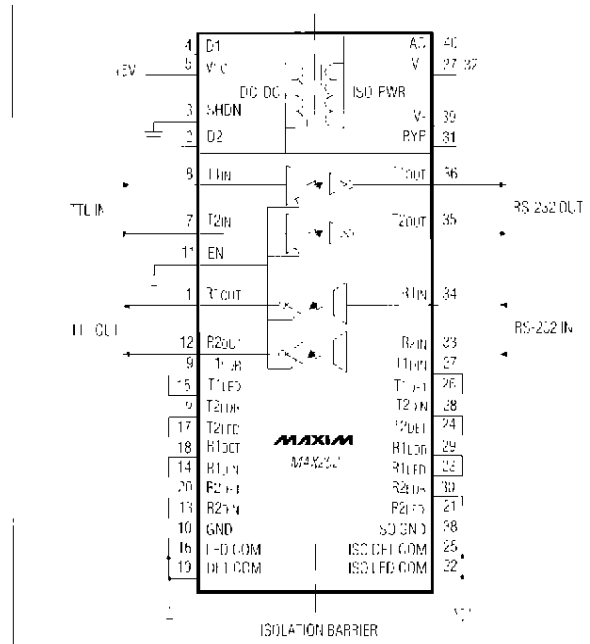

**Complete, +5V-Powered, Isolated, Dual RS-232 Transceiver Module**

**Typical Operating Characteristics**

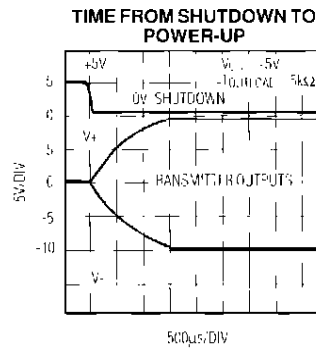
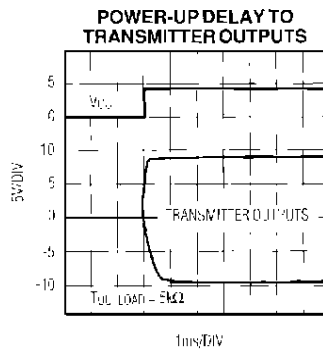
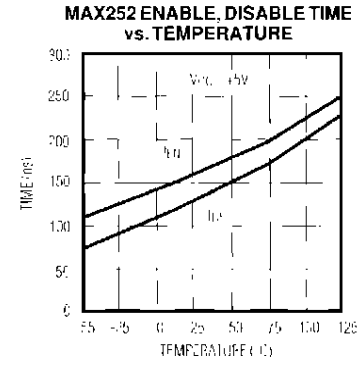
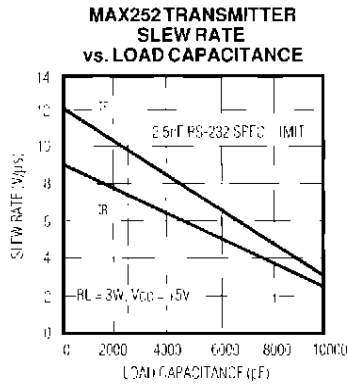
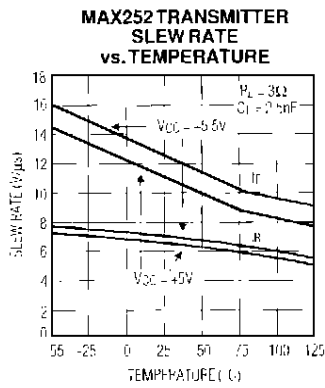

# Complete, +5V-Powered, Isolated, Dual RS-232 Transceiver Module

## Pin Description

**MAX252**

PIN #	NAME	FUNCTION	PIN #	NAME	FUNCTION
1	R1OUT	Receiver #1 Output: TTL/CMOS logic levels	21	R2LED	R2 LED Cathode Input
2	I22	Internal Connection. Leave this pin unconnected. Do not ground.	22	ISO LED COM	Common R1LED, R2LED Cathode. Tie to Isolated Ground.
3	SHDN	Shutdown. When high, turns off the oscillator and disconnects driver inputs. Ground for normal operation.	23	R1LED	R1 LED Cathode Input
4	D1	Internal Connection. Leave this pin unconnected. Do not ground.	24	T2DE	T2 Photodiode Anode Output
5	VCC	+5V Supply Voltage	25	ISO DET COM	Common T1DET, T2DET LED Anode. Tie to Isolated Ground.
6	T2LDR	Transmitter #2 LED Driver	26	T1DET	T1 Photodiode Anode Output
7	I2IN	Transmitter #2 Input: TTL/CMOS logic levels	27	T1DIN	Transmitter #1 Detector Input
8	T1IN	Transmitter #1 Input: TTL/CMOS logic levels	28	T2DIN	Transmitter #2 Detector Input
9	T1LDR	Transmitter #1 LED Driver	29	R1LDR	Receiver #1 LED Driver
10	GND	Ground	30	R2LDR	Receiver #2 LED Driver
11	EN	Output Enable. If high, T1LDR, T2LDR, R1OUT, and R2OUT go to high-impedance state. Ground for normal operation.	31	GYP	Internal Connection. Leave this pin unconnected. Do not ground.
12	R2OUT	Receiver #2 Output: TTL/CMOS logic levels	32	V+	Isolated Positive Supply
13	R2DIN	Receiver #2 Detector Input	33	R2IN	RS-232 Receiver #2 Input
14	R1DIN	Receiver #1 Detector Input	34	R1IN	RS-232 Receiver #1 Input
15	T1LED	T1 LED Anode Input	35	T2OUT	RS-232 Transmitter #2 Output
16	LED COM	Common T1LED, T2LED Cathode. Tie to Ground.	36	T1OUT	RS-232 Transmitter #1 Output
17	T2FD	T2 LED Anode Input	37	V+	Isolated Positive Supply
18	R1DET	R1 Photodiode Cathode Output	38	ISO GND	Isolated Ground
19	DET1 COM	Common R1DET, R2DET Anode. Tie to Ground.	39	V-	Isolated Negative Supply Voltage
20	R2DET	R2 Photodiode Cathode Output	40	AC	Internal Connection. Leave this pin unconnected. Do not ground.

# Complete, +5V-Powered, Isolated, Dual RS-232 Transceiver Module

## Isolation Applications

The MAX252 is intended for industrial communications and control applications where voltage transients, differential ground potentials or high noise may be encountered. The MAX252A withstands 130V<sub>RMS</sub> (continuous), 1260V<sub>RMS</sub> (1 min.) or 1520V<sub>RMS</sub> (1 sec.). For less stringent applications, the MAX252B is rated at 500V<sub>RMS</sub> (1 min.) or 600V<sub>RMS</sub> (1 sec.). For applications requiring higher isolation ratings or transmission rates greater than 9600 baud Maxim recommends the MAX250 and MAX251 device set that uses external optocouplers and transformer.

Figure 1 shows the typical interconnection for a complete 9600 bits/sec transceiver. Important layout considerations include:

- † For maximum isolation, the isolation line through the center of Figure 1 should not be breached; connections from each side should be kept separate.
- † Optocoupler outputs (pins 18, 20, 24, and 26) are high-impedance nodes, so connecting traces should be

as short as possible to minimize stray capacitance and maximize data transfer rate, shunt capacitance seen by each pin should not exceed 10pF.

The MAX252 pin out enables optimal printed circuit board layout by minimizing interconnect lengths and cross-overs. Figure 2 shows the preferred layout, which is strongly recommended for 9600 bits/sec applications. Note the position of the ground traces, particularly the protection of pin 20 by the wraparound from pin 19.

## Isolation Example

Figure 3 illustrates how to isolate an existing RS-232 interface by inserting a MAX252 and MAX233 in series. Both devices invert while translating RS-232 to TTL and TTL to RS-232 levels. Since there is no net inversion, the circuit functions like two plain pieces of wire, but with 1520V<sub>RMS</sub> (at 1 sec.) isolation between the ports.

## Detailed Description

The MAX252 contains two integrated circuits, four optocouplers, four capacitors, two diodes, and a small transformer. Together these provide a complete, isolated, dual RS-232 transmitter and receiver. The non-isolated or logic side of the interface transfers logic signals to and from the optocouplers, while the isolated or cable side transfers data between the optocouplers and RS-232

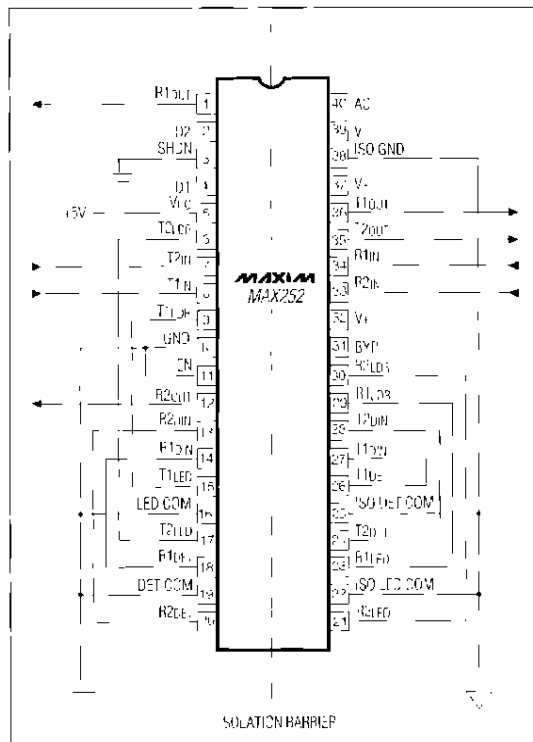

Figure 1. Typical interconnections

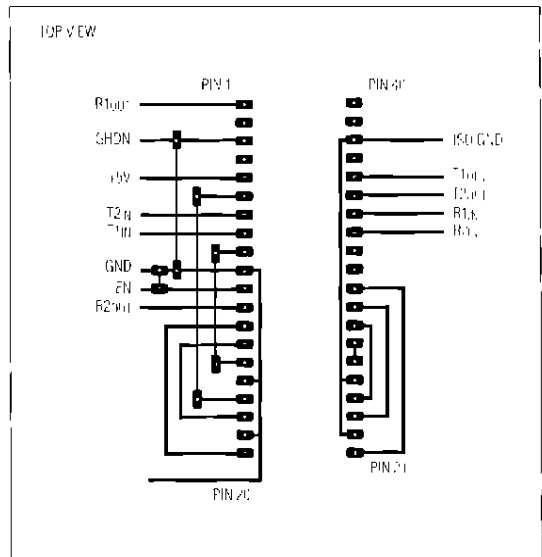

Figure 2. Preferred Layout

## Complete, +5V-Powered, Isolated, Dual RS-232 Transceiver Module

MAX252

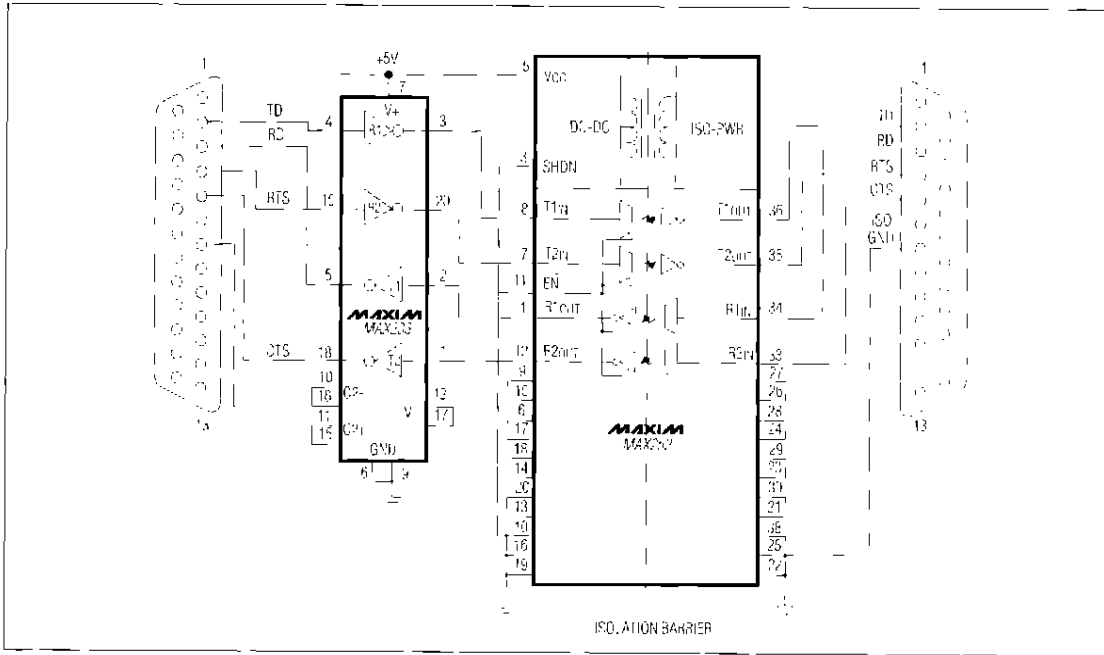

Figure 3. RS-232 Isolation Adapter from a Single +5V Supply

transmitters (line drivers) and receivers. The MAX252 also contains an isolation transformer and drive circuitry to supply power to the isolated side of the interface.

On the logic side of the MAX252 are four identical non-inverting drivers whose outputs may be used either as optocoupler LED drivers or as TTL/CMOS logic outputs. Each driver input (T1<sub>IN</sub>, T2<sub>IN</sub>, R1<sub>DIN</sub>, R2<sub>DIN</sub>) has a weak 4μA internal pull-up current source, and 0.5V hysteresis to improve noise rejection; logic thresholds for the driver inputs conform to standard TTL/CMOS specifications.

The RS-232 side of the interface includes two line drivers and receivers along with circuitry to translate these levels to optocoupler signals. The RS-232 inputs (R1<sub>IN</sub>, R2<sub>IN</sub>) and outputs (T1<sub>OUT</sub>, T2<sub>OUT</sub>) conform to EIA RS-232D and CCITT V.28 specifications. The inputs to the RS-232 line drivers (T1<sub>DIN</sub>, T2<sub>DIN</sub>), which are normally strapped to the internal optoisolators, are TTL/CMOS compatible.

Also included are an OUTPUT ENABLE control (EN) and a SHUTDOWN pin (SHDN). EN places all driver outputs in a high-impedance state when driven high. SHDN, when pulled high, performs the following functions:

- 1) Turns off the 130kHz oscillator, removing power from the RS-232 side of the interface.
- 2) Places T1<sub>OUT</sub> and T2<sub>OUT</sub> in a high-impedance state.
- 3) Disables the 4μA pull-up currents at the logic-side driver inputs (T1<sub>IN</sub>, T2<sub>IN</sub>, R1<sub>DIN</sub>, R2<sub>DIN</sub>.)
- 4) Resets logic-side driver outputs (T1<sub>OUT</sub>, T2<sub>OUT</sub>, R1<sub>OUT</sub>, R2<sub>OUT</sub>) to low.
- 5) Reduces power consumption to 50μW.

### Module Product Reliability

For reliability data on Maxim's Module Product Line, see Reliability Report RR-3A.

**MAX252**

# Complete, +5V-Powered, Isolated, Dual RS-232 Transceiver Module

**MAX252 Block Diagram**

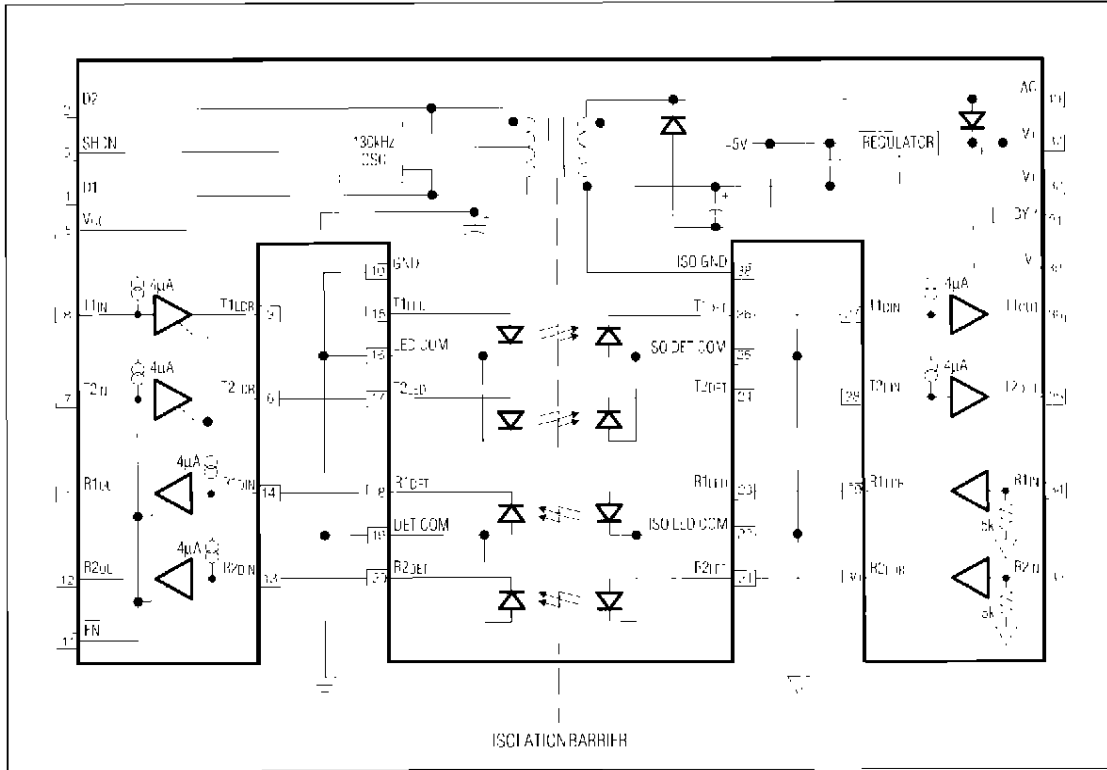

Maxim cannot assume responsibility for use of any circuitry other than circuitry entirely embodied in a Maxim product. No circuit patent licenses are implied. Maxim reserves the right to change the circuitry and specifications without notice at any time.

8 Maxim Integrated Products, 120 San Gabriel Drive, Sunnyvale, CA 94086 (408) 737-7600

©1994 Maxim Integrated Products

Printed USA

MAXIM is a registered trademark of Maxim Integrated Products.